

**M2F2G64CB88B7N / M2F4G64CB8HB5N
M2F2G64CB88BHN / M2F4G64CB8HB9N
2GB: 256M x 64 / 4GB: 512M x 64PC3-8500 / PC3-10600/PC-12800
Unbuffered DDR3 SDRAM DIMM**



Based on DDR3-1066/1333/1600 256Mx8 (2GB/4GB) SDRAM B-Die

Features

•Performance:

Speed Sort	PC3-8500	PC3-10600	PC3-12800	Unit
	-BE	-CG	-DI	
DIMM CAS Latency	7	9	11	
fck – Clock Frequency	533	667	800	MHz
tck – Clock Cycle	1.875	1.5	1.25	ns
fDQ – DQ Burst Frequency	1066	1333	1600	Mbps

- 240-Pin Dual In-Line Memory Module (UDIMM)
- 256Mx64 (2GB) / 512Mx64 (4GB) DDR3 Unbuffered DIMM based on 256Mx8 DDR3 SDRAM B-Die devices.
- Intended for 533MHz/667MHz/800MHz applications
- Inputs and outputs are SSTL-15 compatible
- $V_{DD} = V_{DDQ} = 1.5V \pm 0.075V$
- SDRAMs have 8 internal banks for concurrent operation
- Differential clock inputs
- Data is read or written on both clock edges
- DRAM DLL aligns DQ and DQS transitions with clock transitions.
- Address and control signals are fully synchronous to positive clock edge
- Nominal and Dynamic On-Die Termination support
- Halogen free product
- Programmable Operation:
 - DIMM CAS Latency: 6,7,8,9,10,11
 - Burst Type: Sequential or Interleave
 - Burst Length: BC4, BL8
 - Operation: Burst Read and Write
- Two different termination values (Rtt_Nom & Rtt_WR)
- 15/10/1 (row/column/rank) Addressing for 2GB
- 15/10/2 (row/column/rank) Addressing for 4GB
- Extended operating temperature range
- Auto Self-Refresh option
- Serial Presence Detect
- Gold contacts
- 2GB/4GB SDRAMs are in 78-ball BGA Package
- RoHS compliance and Halogen free

Description

M2F2G64CB88B7N / M2F4G64CB8HB5N / M2F2G64CB88BHN / M2F4G64CB8HB9N are 240-Pin Double Data Rate 3 (DDR3) Synchronous DRAM Unbuffered Dual In-Line Memory Module (UDIMM), organized as one rank of 256Mx64 (2GB) and two ranks of 512Mx64 (4GB) high-speed memory array. Modules use eight 256Mx8 (2GB) 78-ball BGA packaged devices and sixteen 256Mx8 (4GB) 78-ball BGA packaged devices. These DIMMs are manufactured using raw cards developed for broad industry use as reference designs. The use of these common design files minimizes electrical variation between suppliers. All Elixir DDR3 SDRAM DIMMs provide a high-performance, flexible 8-byte interface in a 5.25" long space-saving footprint.

The DIMM is intended for use in applications operating of 533MHz/667MHz/800MHz clock speeds and achieves high-speed data transfer rates of 1066Mbps/1333Mbps/1600Mbps. Prior to any access operation, the device CAS latency and burst/length/operation type must be programmed into the DIMM by address inputs A0-A14 (2GB/4GB) and I/O inputs BA0-BA2 using the mode register set cycle.

The DIMM uses serial presence-detect implemented via a serial EEPROM using a standard IIC protocol. The first 128 bytes of SPD data are programmed and locked during module assembly. The remaining 128 bytes are available for use by the customer.

Ordering Information

M2F2G64CB88B7N / M2F4G64CB8HB5N
M2F2G64CB88BHN / M2F4G64CB8HB9N
2GB: 256M x 64 / 4GB: 512M x 64PC3-8500 / PC3-10600/PC-12800
Unbuffered DDR3 SDRAM DIMM



Part Number	Speed			Organization	Power	Leads	Note
M2F2G64CB88B7N-BE	DDR3-1066	PC3-8500	533MHz (1.875ns @ CL = 7)	256Mx64	1.5V	Gold	
M2F2G64CB88B7N-CG	DDR3-1333	PC3-10600	667MHz (1.5ns @ CL = 9)				
M2F2G64CB88B7N-DI	DDR3-1600	PC3-12800	800MHz (1.25ns @ CL = 11)				
M2F4G64CB8HB5N-BE	DDR3-1066	PC3-8500	533MHz (1.875ns @ CL = 7)	512Mx64			
M2F4G64CB8HB5N-CG	DDR3-1333	PC3-10600	667MHz (1.5ns @ CL = 9)				
M2F4G64CB8HB5N-DI	DDR3-1600	PC3-12800	800MHz (1.25ns @ CL= 11)				
M2F2G64CB88BHN-BE	DDR3-1066	PC3-8500	533MHz (1.875ns @ CL = 7)	256Mx64			
M2F2G64CB88BHN-CG	DDR3-1333	PC3-10600	667MHz (1.5ns @ CL = 9)				
M2F2G64CB88BHN-DI	DDR3-1600	PC3-12800	800MHz (1.25ns @ CL= 11)				
M2F4G64CB8HB9N-BE	DDR3-1066	PC3-8500	533MHz (1.875ns @ CL = 7)	512Mx64			
M2F4G64CB8HB9N-CG	DDR3-1333	PC3-10600	667MHz (1.5ns @ CL = 9)				
M2F4G64CB8HB9N-DI	DDR3-1600	PC3-12800	800MHz (1.25ns @ CL= 11)				

Pin Description

Pin Name	Description	Pin Name	Description
CK0, CK1	Clock Inputs, positive line	DQ0-DQ63	Data input/output
$\overline{\text{CK0}}, \overline{\text{CK1}}$	Clock Inputs, negative line	DQS0-DQS8	Data strobes
CKE0, CKE1	Clock Enable	$\overline{\text{DQS0}}-\overline{\text{DQS8}}$	Data strobes complement
$\overline{\text{RAS}}$	Row Address Strobe	DM0-DM8	Data Masks
$\overline{\text{CAS}}$	Column Address Strobe	$\overline{\text{EVENT}}$	Temperature event pin
$\overline{\text{WE}}$	Write Enable	$\overline{\text{RESET}}$	Reset pin
$\overline{\text{S0}}, \overline{\text{S1}}$	Chip Selects	$V_{\text{REFDQ}}, V_{\text{REFCA}}$	Input/Output Reference
A0-A9, A11, A13-A15	Address Inputs	V_{DDSPD}	SPD and Temp sensor power
A10/AP	Address Input/Auto-Precharge	SA0, SA1	Serial Presence Detect Address Inputs
A12/ $\overline{\text{BC}}$	Address Input/Burst Chop	Vtt	Termination voltage
BA0-BA2	SDRAM Bank Address Inputs	V_{SS}	Ground
ODT0, ODT1	Active termination control lines	V_{DD}	Core and I/O power
SCL	Serial Presence Detect Clock Input	NC	No Connect
SDA	Serial Presence Detect Data input/output		

DDR3 SDRAM Pin Assignment

Pin	Front	Pin	Back	Pin	Front	Pin	Back	Pin	Front	Pin	Back	Pin	Front	Pin	Back
1	V _{REFDQ}	121	V _{SS}	31	DQ25	151	V _{SS}	61	A2	181	A1	91	DQ41	211	V _{SS}
2	V _{SS}	122	DQ4	32	V _{SS}	152	DM3,DQS12,T DQS12	62	V _{DD}	182	V _{DD}	92	V _{SS}	212	DM5, DQS14, TDQS14
3	DQ0	123	DQ5	33	$\overline{\text{DQS3}}$	153	NC, $\overline{\text{DQS12}}$, TDQS12	63	CK1,NC	183	V _{DD}	93	$\overline{\text{DQS5}}$	213	NC, DQS14, TDQS14
4	DQ1	124	V _{SS}	34	DQS3	154	V _{SS}	64	$\overline{\text{CK1}}$,NC	184	CK0	94	DQS5	214	V _{SS}
5	V _{SS}	125	DM0,DQS9, TDQS9	35	V _{SS}	155	DQ30	65	V _{DD}	185	$\overline{\text{CK0}}$	95	V _{SS}	215	DQ46
6	$\overline{\text{DQS0}}$	126	NC,DQS9, TDQS9	36	DQ26	156	DQ31	66	V _{DD}	186	V _{DD}	96	DQ42	216	DQ47
7	DQS0	127	V _{SS}	37	DQ27	157	V _{SS}	67	V _{REFCA}	187	EVENT, NC	97	DQ43	217	V _{SS}
8	V _{SS}	128	DQ6	38	V _{SS}	158	CB4,NC	68	PAR_IN, NC	188	A0	98	V _{SS}	218	DQ52
9	DQ2	129	DQ7	39	CB0,NC	159	CB5,NC	69	V _{DD}	189	V _{DD}	99	DQ48	219	DQ53
10	DQ3	130	V _{SS}	40	CB1,NC	160	V _{SS}	70	A10/AP	190	BA1	100	DQ49	220	V _{SS}
11	V _{SS}	131	DQ12	41	V _{SS}	161	DM8,DQS17, TDQS17,NC	71	BA0	191	V _{DD}	101	V _{SS}	221	DM6, DQS15, TDQS15
12	DQ8	132	DQ13	42	$\overline{\text{DQS8}}$	162	NC, $\overline{\text{DQS17}}$, TDQS17,	72	V _{DD}	192	$\overline{\text{RAS}}$	102	$\overline{\text{DQS6}}$	222	NC, DQS15, TDQS15
13	DQ9	133	V _{SS}	43	DQS8	163	V _{SS}	73	$\overline{\text{WE}}$	193	$\overline{\text{S0}}$	103	DQS6	223	V _{SS}
14	V _{SS}	134	DM1, DQS10, TDQS10	44	V _{SS}	164	CB6,NC	74	$\overline{\text{CAS}}$	194	V _{DD}	104	V _{SS}	224	DQ54
15	$\overline{\text{DQS1}}$	135	NC, $\overline{\text{DQS10}}$, TDQS10	45	CB2,NC	165	CB7,NC	75	V _{DD}	195	ODT0	105	DQ50	225	DQ55
16	DQS1	136	V _{SS}	46	CB3,NC	166	V _{SS}	76	$\overline{\text{S1}}$,NC	196	A13	106	DQ51	226	V _{SS}
17	V _{SS}	137	DQ14	47	V _{SS}	167	NC(TEST)	77	ODT1,NC	197	V _{DD}	107	V _{SS}	227	DQ60
18	DQ10	138	DQ15	48	V _{TT} ,NC	168	$\overline{\text{RESET}}$	78	V _{DD}	198	$\overline{\text{S3}}$,NC	108	DQ56	228	DQ61
19	DQ11	139	V _{SS}	49	V _{TT} ,NC	169	CKE1/NC	79	$\overline{\text{S2}}$,NC	199	V _{SS}	109	DQ57	229	V _{SS}
20	V _{SS}	140	DQ20	50	CKE0	170	V _{DD}	80	V _{SS}	200	DQ36	110	V _{SS}	230	DM7, DQS16, TDQS16
21	DQ16	141	DQ21	51	V _{DD}	171	A15,NC	81	DQ32	201	DQ37	111	$\overline{\text{DQS7}}$	231	NC, DQS16, TDQS16
22	DQ17	142	V _{SS}	52	BA2	172	A14	82	DQ33	202	V _{SS}	112	DQS7	232	V _{SS}
23	V _{SS}	143	DM2, DQS11, TDQS11	53	$\overline{\text{ERR_OUT}}$, NC	173	V _{DD}	83	V _{SS}	203	DM4, DQS13, TDQS13	113	V _{SS}	233	DQ62
24	$\overline{\text{DQS2}}$	144	NC, $\overline{\text{DQS11}}$, TDQS11	54	V _{DD}	174	A12/BC	84	$\overline{\text{DQS4}}$	204	NC, DQS13, TDQS13	114	DQ58	234	DQ63
25	DQS2	145	V _{SS}	55	A11	175	A9	85	DQS4	205	V _{SS}	115	DQ59	235	V _{SS}
26	V _{SS}	146	DQ22	56	A7	176	V _{DD}	86	V _{SS}	206	DQ38	116	V _{SS}	236	V _{DDSPD}
27	DQ18	147	DQ23	57	V _{DD}	177	A8	87	DQ34	207	DQ39	117	SA0	237	SA1
28	DQ19	148	V _{SS}	58	A5	178	A6	88	DQ35	208	V _{SS}	118	SCL	238	SDA
29	V _{SS}	149	DQ28	59	A4	179	V _{DD}	89	V _{SS}	209	DQ44	119	SA2	239	V _{SS}
30	DQ24	150	DQ29	60	V _{DD}	180	A3	90	DQ40	210	DQ45	120	V _{TT}	240	V _{TT}

Note: CK1, $\overline{\text{CK1}}$, CEK1, $\overline{\text{S1}}$ and ODT1 are for 4GB modules only.

Input/Output Functional Description

Symbol	Type	Polarity	Function
CK0, CK1 CK0, CK1	Input	Cross point	The system clock inputs. All address and command lines are sampled on the cross point of the rising edge of CK and falling edge of CK. A Delay Locked Loop (DLL) circuit is driven from the clock inputs and output timing for read operations is synchronized to the input clock.
CKE0, CKE1	Input	Active High	Activates the DDR3 SDRAM CK signal when high and deactivates the CK signal when low. By deactivating the clocks, CKE low initiates the Power Down mode or the Self Refresh mode.
S0, S1	Input	Active Low	Enables the associated DDR3 SDRAM command decoder when low and disables the command decoder when high. When the command decoder is disabled, new commands are ignored but previous operations continue, Rank 0 is selected by S0; Rank 1 is selected by S1.
RAS, CAS, WE	Input	Active Low	When sampled at the positive rising edge of CK and falling edge of CK, signals RAS, CAS, WE define the operation to be executed by the SDRAM.
ODT0, ODT1	Input	Active High	Asserts on-die termination for DQ, DM, DQS, and DQS signals if enabled via the DDR3 SDRAM mode register.
DM0 – DM8	Input	Active High	The data write masks, associated with one data byte. In Write mode, DM operates as a byte mask by allowing input data to be written if it is low but blocks the write operation if it is high. In Read mode, DM lines have no effect.
DQS0 – DQS8 DQS0 – DQS8	I/O	Cross point	The data strobes, associated with one data byte, sourced with data transfers. In Write mode, the data strobe is sourced by the controller and is centered in the data window. In Read mode, the data strobe is sourced by the DDR3 SDRAM and is sent at the leading edge of the data window. DQS signals are complements, and timing is relative to the cross point of respective DQS and DQS. If the module is to be operated in single ended strobe mode, all DQS signals must be tied on the system board to Vss and DDR3 SDRAM mode registers programmed appropriately.
BA0, BA1, BA2	Input	-	Selects which DDR3 SDRAM internal bank of four or eight is activated.
A0 – A9 A10/AP A11 A12/BC A13-A15	Input	-	During a Bank Activate command cycle, defines the row address when sampled at the cross point of the rising edge of CK and falling edge of CK. During a Read or Write command cycle, defines the column address when sampled at the cross point of the rising edge of CK and falling edge of CK. In addition to the column address, AP is used to invoke autoprecharge operation at the end of the burst read or write cycle. If AP is high, autoprecharge is selected and BA0-BAn defines the bank to be precharged. If AP is low, autoprecharge is disabled. During a Precharge command cycle, AP is used in conjunction with BA0-BAn to control which bank(s) to precharge. If AP is high, all banks will be precharged regardless of the state of BA0-BAn inputs. If AP is low, then BA0-BAn are used to define which bank to precharge.
DQ0 – DQ63	Input	-	Data Input/Output pins.
VDD, VDDSPD, VSS	Supply	-	Power supplies for core, I/O, Serial Presence Detect, Temp sensor, and ground for the module.
VREFDQ, VREFCA	Supply	-	Reference voltage for SSTL15 inputs
SDA	I/O	-	This is a bidirectional pin used to transfer data into or out of the SPD EEPROM and temp sensor. A resistor must be connected from the SDA bus line to VDDSPD on the system planar to act as a pull up.
SCL	Input	-	This signal is used to clock data into and out of the SPD EEPROM and Temp sensor.
SA0 – SA2	Input	-	Address pins used to select the Serial Presence Detect and Temp sensor base address.
EVENT	Output	-	The EVENT pin is reserved for use to flag critical module temperature.
RESET	Input	-	This signal resets the DDR3 SDRAM

Functional Block Diagram

[2GB – 1 Rank, 256Mx8 DDR3 SDRAMs]

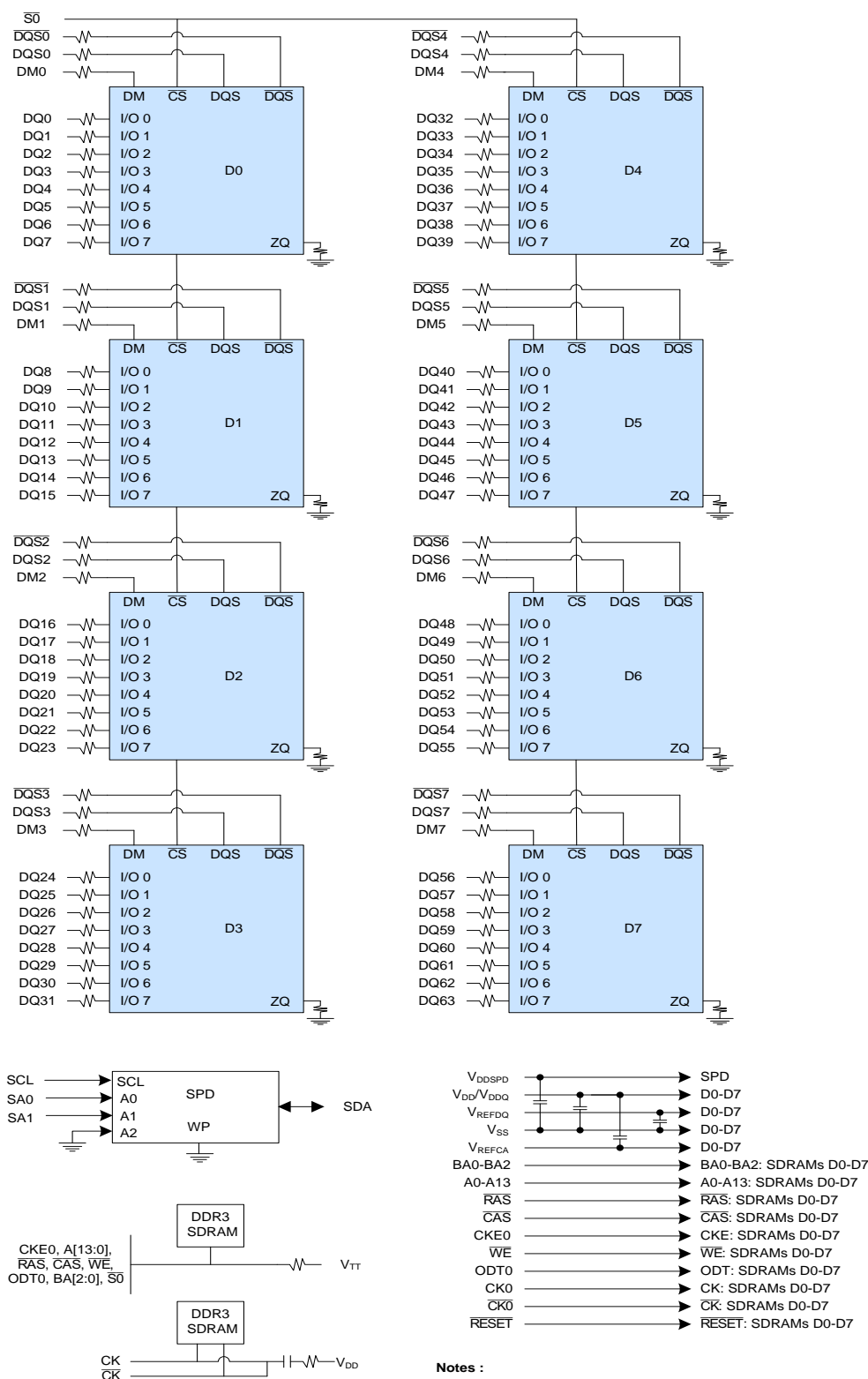

Notes :

1. DQ-to-I/O wiring is shown as recommended but may be changed.
2. DQ/DQS/DQS/ODT/DM/CKE/S relationships must be maintained as shown.
3. For each DRAM, a unique ZQ resistor is connected to ground. The ZQ resistor is 240Ω ±1%.
4. One SPD exists per module.

Functional Block Diagram

[4GB – 2 Ranks, 256Mx8 DDR3 SDRAMs]

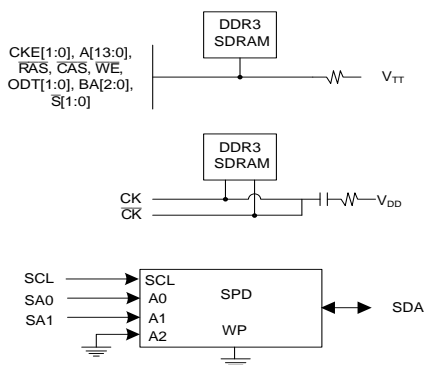
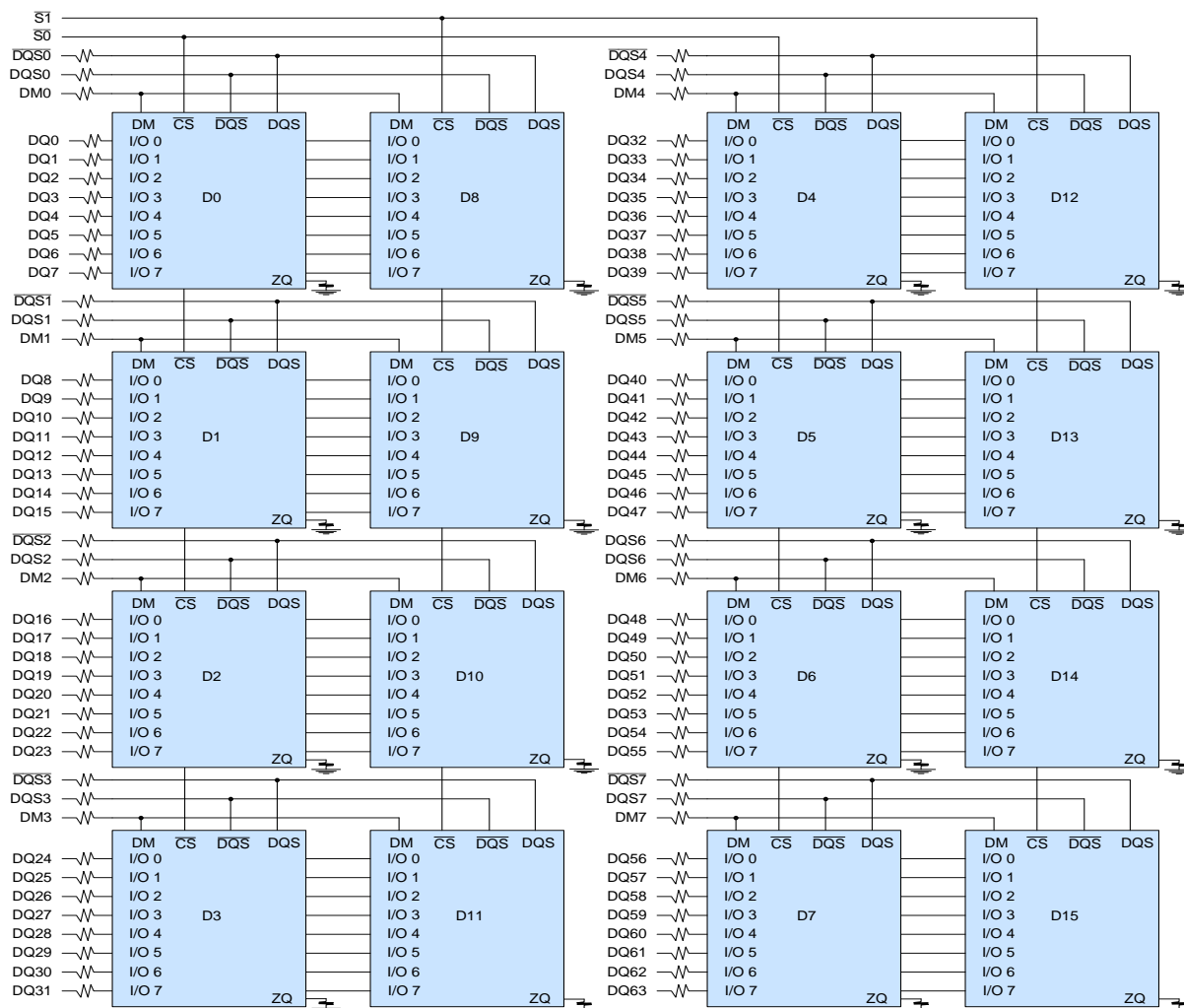

V _{DDSPD}	→	SPD
V _{DD} /V _{DDQ}	→	D0-D15
V _{REFDQ}	→	D0-D15
V _{SS}	→	D0-D15
V _{REFCA}	→	D0-D15
BA0-BA2	→	BA0-BA2: SDRAMs D0-D15
A0-A13	→	A0-A13: SDRAMs D0-D15
RAS	→	RAS: SDRAMs D0-D15
CAS	→	CAS: SDRAMs D0-D15
WE	→	WE: SDRAMs D0-D15
CKE0	→	CKE: SDRAMs D0-D7
CKE1	→	CKE: SDRAMs D8-D15
ODT0	→	ODT: SDRAMs D0-D7
ODT1	→	ODT: SDRAMs D8-D15
CK0	→	CK: SDRAMs D0-D7
CK0	→	CK: SDRAMs D0-D7
CK1	→	CK: SDRAMs D8-D15
CK1	→	CK: SDRAMs D8-D15
RESET	→	RESET: SDRAMs D8-D15

Notes :

1. DQ-to-I/O wiring is shown as recommended but may be changed.
2. DQ/DQS/DQS/ODT/DM/CKE/S relationships must be maintained as shown.
3. For each DRAM, a unique ZQ resistor is connected to ground. The ZQ resistor is 240Ω ±1%.
4. One SPD exists per module.

M2F2G64CB88B7N / M2F4G64CB8HB5N
M2F2G64CB88BHN / M2F4G64CB8HB9N
2GB: 256M x 64 / 4GB: 512M x 64PC3-8500 / PC3-10600/PC-12800
Unbuffered DDR3 SDRAM DIMM



Serial Presence Detect [M2F2G64CB88B7N / M2F2G64CB88BHN , 2GB – 1 Rank, 256Mx8 DDR3 SDRAMs]				
Byte	Description	Serial PD Data Entry (Hex.)		
		-BE	-CG	-DG
0	CRC range, EEPROM bytes, bytes used	92	92	93
1	SPD revision	10	10	10
2	DRAM device type	0B	0B	0B
3	Module type (form factor)	02	02	02
4	SDRAM Device density and banks	03	03	03
5	SDRAM device row and column count	19	19	19
6	Module minimum nominal voltage	00	00	00
7	Module ranks and device DQ count	01	01	01
8	ECC tag and module memory Bus width	03	03	03
9	Fine timebase dividend/divisor (in ps)	52	52	52
10	Medium timebase dividend	01	01	01
11	Medium timebase divisor	08	08	08
12	Minimum SDRAM cycle time (tCKmin)	0F	0C	0A
13	Reserved	00	00	00
14	CAS latencies supported	1C	3C	7E
15	CAS latencies supported	00	00	00
16	Minimum CAS latency time (tAAmin)	69	69	64
17	Minimum write recovery time (tWRmin)	78	78	78
18	Minimum CAS-to-CAS delay (tRCDmin)	69	69	64
19	Minimum Row Active to Row Active delay (tRRDmin)	3C	30	30
20	Minimum row Precharge delay (tRPmin)	69	69	64
21	Upper nibble for tRAS and tRC	11	11	11
22	Minimum Active-to-Precharge delay (tRASmin)	2C	20	18
23	Minimum Active-to-Active/Refresh delay (tRCmin)	95	89	7C
24	Minimum refresh recovery delay (tRFCmin) LSB	00	00	00
25	Minimum refresh recovery delay (tRFCmin) MSB	05	05	05
26	Minimum internal Write-to-Read command delay (tWTRmin)	3C	3C	3C
27	Minimum internal Read-to-Precharge command delay (tRTPmin)	3C	3C	3C
28	Minimum four active window delay (tFAWmin) LSB	01	00	00
29	Minimum four active window delay (tFAWmin) MSB	2C	F0	F0
30	SDRAM device output drivers supported	83	83	83
31	SDRAM device thermal and refresh options	05	05	05
32	Module Thermal Sensor	00	00	00
33	SDRAM Device Type	00	00	00
60	Module height (nominal)	0F	0F	0F
61	Module thickness (Max)	01	01	01
62	Raw Card ID reference	01	01	01
63	DRAM address mapping edge connector	01	01	01
117	Module manufacture ID	83	83	83
118	Module manufacture ID	0B	0B	0B
119-121	Module manufacturer Information	--	--	--
126	CRC	47	05	FB
127	CRC	29	80	32
128-145	Module part number	--	--	--
146	Module die revision	--	--	--
147	Module PCB revision	--	--	--
150-175	Manufacturer reserved	--	--	--
176-255	Intel Extreme Memory Profile(XMP)	--	--	--

M2F2G64CB88B7N / M2F4G64CB8HB5N
M2F2G64CB88BHN / M2F4G64CB8HB9N
2GB: 256M x 64 / 4GB: 512M x 64PC3-8500 / PC3-10600/PC-12800
Unbuffered DDR3 SDRAM DIMM



Serial Presence Detect [M2F4G64CB8HB5N / M2F4G64CB8HB9N , 4GB – 2 Ranks, 256Mx8 DDR3 SDRAMs]				
Byte	Description	Serial PD Data Entry (Hex.)		
		-BE	-CG	-DG
0	CRC range, EEPROM bytes, bytes used	92	92	93
1	SPD revision	10	10	10
2	DRAM device type	0B	0B	0B
3	Module type (form factor)	02	02	02
4	SDRAM Device density and banks	03	03	03
5	SDRAM device row and column count	19	19	19
6	Module minimum nominal voltage	00	00	00
7	Module ranks and device DQ count	09	09	09
8	ECC tag and module memory Bus width	03	03	03
9	Fine timebase dividend/divisor (in ps)	52	52	52
10	Medium timebase dividend	01	01	01
11	Medium timebase divisor	08	08	08
12	Minimum SDRAM cycle time (tCKmin)	0F	0C	0A
13	Reserved	00	00	00
14	CAS latencies supported	1C	3C	7E
15	CAS latencies supported	00	00	00
16	Minimum CAS latency time (tAAmin)	69	69	64
17	Minimum write recovery time (tWRmin)	78	78	78
18	Minimum CAS-to-CAS delay (tRCDmin)	69	69	64
19	Minimum Row Active to Row Active delay (tRRDmin)	3C	30	30
20	Minimum row Precharge delay (tRPmin)	69	69	64
21	Upper nibble for tRAS and tRC	11	11	11
22	Minimum Active-to-Precharge delay (tRASmin)	2C	20	18
23	Minimum Active-to-Active/Refresh delay (tRCmin)	95	89	7C
24	Minimum refresh recovery delay (tRFCmin) LSB	00	00	00
25	Minimum refresh recovery delay (tRFCmin) MSB	05	05	05
26	Minimum internal Write-to-Read command delay (tWTRmin)	3C	3C	3C
27	Minimum internal Read-to-Precharge command delay (tRTPmin)	3C	3C	3C
28	Minimum four active window delay (tFAWmin) LSB	01	00	00
29	Minimum four active window delay (tFAWmin) MSB	2C	F0	F0
30	SDRAM device output drivers supported	83	83	83
31	SDRAM device thermal and refresh options	05	05	05
32	Module Thermal Sensor	00	00	00
33	SDRAM Device Type	00	00	00
60	Module height (nominal)	0F	0F	0F
61	Module thickness (Max)	11	11	11
62	Raw Card ID reference	01	01	01
63	DRAM address mapping edge connector	01	01	01
117	Module manufacture ID	83	83	83
118	Module manufacture ID	0B	0B	0B
119-121	Module manufacturer Information	--	--	--
126	CRC	68	2A	D4
127	CRC	59	F0	42
128-145	Module part number	--	--	--
146	Module die revision	--	--	--
147	Module PCB revision	--	--	--
150-175	Manufacturer reserved	--	--	--
176-255	Intel Extreme Memory Profile(XMP)	--	--	--

Environmental Requirements

Symbol	Parameter	Rating	Units	Note
T _{OPR}	Module Operating Temperature Range (ambient)	0 to 55	°C	3
H _{OPR}	Operating Humidity (relative)	10 to 90	%	1
T _{STG}	Storage Temperature (Plastic)	-55 to 100	°C	1
H _{STG}	Storage Humidity (without condensation)	5 to 95	%	1
P _{BAR}	Barometric Pressure (operating & storage)	105 to 69	K Pascal	1, 2

Note:

- Stresses greater than those listed may cause permanent damage to the device. This is a stress rating only and device functional operation at or above the conditions indicated is not implied. Exposure to absolute maximum rating conditions for extended periods may affect reliability.
- Up to 9850 ft.
- The component maximum case temperature shall not exceed the value specified in the component spec.

Absolute Maximum DC Ratings

Symbol	Parameter	Rating	Units	Note
V _{DD}	Voltage on VDD pins relative to Vss	-0.4 V ~ 1.975 V	V	1, 3
V _{DDQ}	Voltage on VDDQ pins relative to Vss	-0.4 V ~ 1.975 V	V	1, 3
V _{IN} , V _{OUT}	Voltage on I/O pins relative to Vss	-0.4 V ~ 1.975 V	V	1
T _{STG}	Storage Temperature	-55 to +100	°C	1, 2

Note:

- Stresses greater than those listed under “Absolute Maximum Ratings” may cause permanent damage to the device. This is a stress rating only and functional operation of the device at these or any other conditions above those indicated in the operational sections of this specification is not implied. Exposure to absolute maximum rating conditions for extended periods may affect reliability
- Storage Temperature is the case surface temperature on the center/top side of the DRAM. For the measurement conditions, please refer to JESD51-2 standard.
- VDD and VDDQ must be within 300 mV of each other at all times;and VREF must be not greater

Operating temperature Conditions

Symbol	Parameter	Rating	Units	Note
T _{OPER}	Normal Operating Temperature Range	0 to 85	°C	1, 2
	Extended Temperature Range	85 to 95	°C	1, 3

Note:

- Operating Temperature TOPER is the case surface temperature on the center / top side of the DRAM. For measurement conditions, please refer to the JEDEC document JESD51-2.
- The Normal Temperature Range specifies the temperatures where all DRAM specifications will be supported. During operation, the DRAM case temperature must be maintained between 0 to 85 °C under all operating conditions
- Some applications require operation of the DRAM in the Extended Temperature Range between 85 °C and 95 °C case temperature. Full specifications are supported in this range, but the following additional conditions apply:
 - Refresh commands must be doubled in frequency, therefore reducing the Refresh interval tREFI to 3.9 μs. It is also possible to specify a component with 1X refresh (tREFI to 7.8μs) in the Extended Temperature Range. Please refer to supplier data sheet and/or the DIMM SPD for option availability.
 - If Self-Refresh operation is required in the Extended Temperature Range, then it is mandatory to either use the Manual Self-Refresh mode with Extended Temperature Range capability (MR2 A6 = 0b and MR2 A7 = 1b) or enable the optional Auto Self-Refresh mode (MR2 A6 = 1b and MR2 A7 = 0b). Please refer to the supplier data sheet and/or the DIMM SPD for Auto Self-Refresh option availability, Extended Temperature Range support and tREFI requirements in the Extended Temperature Range.

DC Electrical Characteristics and Operating Conditions

Symbol	Parameter	Min	Typ	Max	Units	Notes
VDD	Supply Voltage	1.425	1.5	1.575	V	1,2
VDDQ	Output Supply Voltage	1.425	1.5	1.575	V	1,2

Note:

- Under all conditions VDDQ must be less than or equal to VDD.
- VDDQ tracks with VDD. AC parameters are measured with VDD and VDDQ tied together.

Single-Ended AC and DC Input Levels for Command and Address

Symbol	Parameter	DDR3-1066 (-BE)		DDR3-1333 (-CG)		DDR3-1600 (-DI)		Units	Note
		Min.	Max.	Min.	Max.	Min.	Max.		
VIH.CA(DC)	DC Input Logic High	Vref + 0.100	VDD	Vref + 0.100	VDD	Vref + 0.100	VDD	V	1
VIL.CA(DC)	DC Input Logic Low	VSS	Vref - 0.100	VSS	Vref - 0.100	VSS	Vref - 0.100	V	1
VIH.CA(AC)	AC Input Logic High	Vref + 0.175	Note 2	Vref + 0.175	Note 2	Vref + 0.175	Note 2	V	1, 2
VIL.CA(AC)	AC Input Logic Low	Note 2	Vref - 0.175	Note 2	Vref - 0.175	Note 2	Vref - 0.175	V	1, 2
VIH.CA(AC150)	AC Input Logic High	Vref + 0.15	Note 2	Vref + 0.15	Note 2	Vref + 0.15	Note 2	V	1, 2
VIL.CA(AC150)	AC Input Logic Low	Note 2	Vref - 0.15	Note 2	Vref - 0.15	Note 2	Vref - 0.15	V	1, 2
V _{RefCA(DC)}	Reference Voltage for ADD, CMD Inputs	0.49 x VDD	0.51 x VDD	0.49 x VDD	0.51 x VDD	0.49 x VDD	0.51 x VDD	V	3, 4

Note:

- For input only pins except RESET#. Vref = VrefCA(DC).
- See "Overshoot and Undershoot Specifications" in the device datasheet.
- The ac peak noise on VRef may not allow VRef to deviate from VRefDQ(DC) by more than +/-1% VDD (for reference: approx. +/- 15 mV).
- For reference: approx. VDD/2 +/- 15 mV.

Single-Ended AC and DC Input Levels for DQ and DM

Symbol	Parameter	DDR3-1066 (-BE)		DDR3-1333 (-CG)		DDR3-1600 (-DI)		Units	Note
		Min.	Max.	Min.	Max.	Min.	Max.		
VIH.DQ(DC)	DC Input Logic High	Vref + 0.100	VDD	Vref + 0.100	VDD	Vref + 0.100	VDD	V	1
VIL.DQ(DC)	DC Input Logic Low	VSS	Vref - 0.100	VSS	Vref - 0.100	VSS	Vref - 0.100	V	1
VIH.DQ(AC)	AC Input Logic High	Vref + 0.175	Note 2	Vref + 0.15	Note 2	Vref + 0.15	Note 2	V	1, 2, 5
VIL.DQ(AC)	AC Input Logic Low	Note 2	Vref - 0.175	Note 2	Vref - 0.15	Note 2	Vref - 0.15	V	1, 2, 5
V _{RefDQ(DC)}	Reference Voltage for DQ, DM Inputs	0.49 x VDD	0.51 x VDD	0.49 x VDD	0.51 x VDD	0.49 x VDD	0.51 x VDD	V	3, 4

Note:

- For input only pins except RESET#. Vref = VrefDQ(DC).
- See "Overshoot and Undershoot Specifications" in the device datasheet.
- The ac peak noise on VRef may not allow VRef to deviate from VRefDQ(DC) by more than +/-1% VDD (for reference: approx. +/- 15 mV).
- For reference: approx. VDD/2 +/- 15 mV.
- Single-ended swing requirement for DQS, DQS# is 350 mV (peak to peak). Differential swing requirement for DQS - DQS# is 700 mV (peak to peak).

Operating, Standby, and Refresh Currents

T_{CASE} = 0 °C ~ 85 °C; V_{DDQ} = V_{DD} = 1.5V ± 0.075V [2GB – 1 Rank, 256Mx8 DDR3 SDRAMs]

Symbol	Parameter/Condition	PC3-8500	PC3-10600	PC3-12800	Unit
		(-BE)	(-CG)	(-DI)	
IDD0	Operating One Bank Active-Precharge Current	577	579	609	mA
IDD1	Operating One Bank Active-Read-Precharge Current	725	750	790	mA
IDD2P0	Precharge Power-Down Current Slow Exit	33	48	51	mA
IDD2P1	Precharge Power-Down Current Fast Exit	104	132	143	mA
IDD2Q	Precharge Quiet Standby Current	167	204	185	mA
IDD2N	Precharge Standby Current	182	220	243	mA
IDD3P	Active Power-Down Current	114	144	158	mA
IDD3N	Active Standby Current	236	231	255	mA
IDD4R	Operating Burst Read Current	1011	1302	1510	mA
IDD4W	Operating Burst Write Current	1028	1239	1438	mA
IDD5B	Burst Refresh Current	1531	1507	1531	mA
IDD6	Self Refresh Current: Normal Temperature Range	83	56	56	mA
IDD7	Operating Bank Interleave Read Current	2590	2997	3062	mA

Operating, Standby, and Refresh Currents

T_{CASE} = 0 °C ~ 85 °C; V_{DDQ} = V_{DD} = 1.5V ± 0.075V [4GB – 2 Ranks, 256Mx8 DDR3 SDRAMs]

Symbol	Parameter/Condition	PC3-8500	PC3-10600	PC3-12800	Unit
		(-BE)	(-CG)	(-DI)	
IDD0	Operating One Bank Active-Precharge Current	813	810	864	mA
IDD1	Operating One Bank Active-Read-Precharge Current	961	980	1045	mA
IDD2P0	Precharge Power-Down Current Slow Exit	66	95	102	mA
IDD2P1	Precharge Power-Down Current Fast Exit	209	264	285	mA
IDD2Q	Precharge Quiet Standby Current	333	408	370	mA
IDD2N	Precharge Standby Current	364	440	486	mA
IDD3P	Active Power-Down Current	228	289	317	mA
IDD3N	Active Standby Current	472	461	510	mA
IDD4R	Operating Burst Read Current	1247	1533	1765	mA
IDD4W	Operating Burst Write Current	1264	1470	1693	mA
IDD5B	Burst Refresh Current	1767	1737	1786	mA
IDD6	Self Refresh Current: Normal Temperature Range	167	113	113	mA
IDD7	Operating Bank Interleave Read Current	2826	3228	3318	mA

Standard Speed Bins

DDR3-1066MHz

Speed Bin			DDR3-1066		Unit
CL-nRCD-nRP			7-7-7 (-BE)		
Parameter	Symbol		Min	Max	
Internal read command to first data	tAA		13.125	20	ns
ACT to internal read or write delay time	tRCD		13.125	-	ns
PRE command period	tRP		13.125	-	ns
ACT to ACT or REF command period	tRC		50.625	-	ns
ACT to PRE command period	tRAS		37.5	9*tREFI	ns
CL=5	CWL=5	tCK(AVG)	3	3.3	ns
	CWL=6	tCK(AVG)	Reserved		ns
CL=6	CWL=5	tCK(AVG)	2.5	3.3	ns
	CWL=6	tCK(AVG)	Reserved		ns
CL=7	CWL=5	tCK(AVG)	Reserved		ns
	CWL=6	tCK(AVG)	1.875	<2.5	ns
CL=8	CWL=5	tCK(AVG)	Reserved		ns
	CWL=6	tCK(AVG)	1.875	<2.5	ns
Supported CL Settings			5,6,7,8		nCK
Supported CWL Settings			5,6		nCK

DDR3-1333MHz

Speed Bin			DDR3-1333		Unit
CL-nRCD-nRP			9-9-9 (-CG)		
Parameter	Symbol		Min	Max	
Internal read command to first data	tAA		13.125	20.000	ns
ACT to internal read or write delay time	tRCD		13.125	-	ns
PRE command period	tRP		13.125	-	ns
ACT to ACT or REF command period	tRC		49.125	-	ns
ACT to PRE command period	tRAS		36	9*tREFI	ns
CL=5	CWL=5	tCK(AVG)	3	3.3	ns
	CWL=6	tCK(AVG)	Reserved	Reserved	ns
	CWL=7	tCK(AVG)	Reserved	Reserved	ns
CL=6	CWL=5	tCK(AVG)	2.5	3.3	ns
	CWL=6	tCK(AVG)	Reserved	Reserved	ns
	CWL=7	tCK(AVG)	Reserved	Reserved	ns
CL=7	CWL=5	tCK(AVG)	Reserved	Reserved	ns
	CWL=6	tCK(AVG)	1.875*	<2.5*	ns
	CWL=7	tCK(AVG)	Reserved	Reserved	ns
CL=8	CWL=5	tCK(AVG)	Reserved	Reserved	ns
	CWL=6	tCK(AVG)	1.875	<2.5	ns
	CWL=7	tCK(AVG)	Reserved	Reserved	ns
CL=9	CWL=5	tCK(AVG)	Reserved	Reserved	ns
	CWL=6	tCK(AVG)	Reserved	Reserved	ns
	CWL=7	tCK(AVG)	1.5	<1.875	ns
CL=10	CWL=5	tCK(AVG)	Reserved	Reserved	ns
	CWL=6	tCK(AVG)	Reserved	Reserved	ns
	CWL=7	tCK(AVG)	1.5*	<1.875*	ns
Supported CL Settings			5,6,7*,8,9,10*		nCK
Supported CWL Settings			5,6,7		nCK

DDR3-1600MHz

Speed Bin		DDR3-1600		Unit	
CL-nRCD-nRP		11-11-11 (-DI)			
Parameter	Symbol	Min	Max		
Internal read command to first data	tAA	13.125	20	ns	
ACT to internal read or write delay time	tRCD	13.125	-	ns	
PRE command period	tRP	13.125	-	ns	
ACT to ACT or REF command period	tRC	48.125	-	ns	
ACT to PRE command period	tRAS	35	9*tREFI	ns	
CL=5	CWL=5	tCK(AVG)	3	3.3	ns
	CWL=6	tCK(AVG)	Reserved	Reserved	ns
	CWL=7	tCK(AVG)	Reserved	Reserved	ns
CL=6	CWL=5	tCK(AVG)	2.5	3.3	ns
	CWL=6	tCK(AVG)	1.875*	<2.5*	ns
	CWL=7	tCK(AVG)	Reserved	Reserved	ns
CL=7	CWL=5	tCK(AVG)	Reserved	Reserved	ns
	CWL=6	tCK(AVG)	1.875*	<2.5*	ns
	CWL=7	tCK(AVG)	Reserved	Reserved	ns
CL=8	CWL=5	tCK(AVG)	Reserved	Reserved	ns
	CWL=6	tCK(AVG)	1.875	<2.5	ns
	CWL=7	tCK(AVG)	1.5	<1.875	ns
CL=9	CWL=5	tCK(AVG)	Reserved	Reserved	ns
	CWL=6	tCK(AVG)	Reserved	Reserved	ns
	CWL=7	tCK(AVG)	1.500	<1.875	ns
CL=10	CWL=5	tCK(AVG)	Reserved	Reserved	ns
	CWL=6	tCK(AVG)	Reserved	Reserved	ns
	CWL=7	tCK(AVG)	1.500*	<1.875*	ns
Supported CL Settings		5,6,7*,8,9*,10,11		nCK	
Supported CWL Settings		5,6,7,8		nCK	

*: Optional

AC Timing Specifications for DDR3 SDRAM Devices Used on Module (1066MHz)

Parameter	Symbol	DDR3-1066		Units	Notes
		Min.	Max.		
Clock Timing					
Minimum Clock Cycle Time (DLL off mode)	tCK (DLL_OFF)	8	-	ns	
Average Clock Period	tCK(avg)	Refer to "Standard Speed Bins"		ps	
Average high pulse width	tCH(avg)	0.47	0.53	tCK(avg)	
Average low pulse width	tCL(avg)	0.47	0.53	tCK(avg)	
Absolute Clock Period	tCK(abs)	Min.: tCK(avg)min + tJIT(per)min Max.: tCK(avg)max + tJIT(per)max		ps	
Absolute clock HIGH pulse width	tCH(abs)	0.43	-	tCK(avg)	
Absolute clock LOW pulse width	tCL(abs)	0.43	-	tCK(avg)	
Clock Period Jitter	JIT(per)	-90	90	ps	
Clock Period Jitter during DLL locking period	JIT(per, lck)	-80	80	ps	
Cycle to Cycle Period Jitter	tJIT(cc)	180	180	ps	
Cycle to Cycle Period Jitter during DLL locking period	JIT(cc, lck)	160	160	ps	
Duty Cycle Jitter	tJIT(duty)	-	-	ps	
Cumulative error across 2 cycles	tERR(2per)	-132	132	ps	
Cumulative error across 3 cycles	tERR(3per)	-157	157	ps	
Cumulative error across 4 cycles	tERR(4per)	-175	175	ps	
Cumulative error across 5 cycles	tERR(5per)	-188	188	ps	
Cumulative error across 6 cycles	tERR(6per)	-200	200	ps	
Cumulative error across 7 cycles	tERR(7per)	-209	209	ps	
Cumulative error across 8 cycles	tERR(8per)	-217	217	ps	
Cumulative error across 9 cycles	tERR(9per)	-224	224	ps	
Cumulative error across 10 cycles	tERR(10per)	-231	231	ps	
Cumulative error across 11 cycles	tERR(11per)	-237	237	ps	
Cumulative error across 12 cycles	tERR(12per)	-242	242	ps	
Cumulative error across n = 13, 14 . . . 49, 50 cycles	tERR(nper)	tERR(nper)min = (1 + 0.68ln(n)) * tJIT(per)min tERR(nper)max = (1 + 0.68ln(n)) * tJIT(per)max		ps	
Data Timing					
DQS, DQS# to DQ skew, per group, per access	tDQSQ	-	150	ps	
DQ output hold time from DQS, DQS#	tQH	0.38	-	tCK(avg)	
DQ low-impedance time from CK, CK#	tLZ(DQ)	-600	300	ps	
DQ high impedance time from CK, CK#	tHZ(DQ)	-	300	ps	
Data setup time to DQS, DQS# referenced to Vih(ac) / Vil(ac) levels	tDS(base) AC175	25		ps	
Data setup time to DQS, DQS# referenced to Vih(ac) / Vil(ac) levels	tDS(base) AC150	75		ps	
Data hold time from DQS, DQS# referenced to Vih(dc) / Vil(dc) levels	tDH(base) DC100	100		ps	
DQ and DM Input pulse width for each input	tDIPW	490		ps	
Data Strobe Timing					
DQS, DQS# differential READ Preamble	tRPRE	0.9	Note 19	tCK(avg)	
DQS, DQS# differential READ Postamble	tRPST	0.3	Note 11	tCK(avg)	
DQS, DQS# differential output high time	tQSH	0.38	-	tCK(avg)	
DQS, DQS# differential output low time	tQSL	0.38	-	tCK(avg)	
DQS, DQS# differential WRITE Preamble	tWPRE	0.9	-	tCK(avg)	
DQS, DQS# differential WRITE Postamble	tWPST	0.3	-	tCK(avg)	
DQS, DQS# rising edge output access time from rising CK, CK#	tDQSCK	-300	300	tCK(avg)	
DQS and DQS# low-impedance time (Referenced from RL - 1)	tLZ(DQS)	-600	300	tCK(avg)	
DQS and DQS# high-impedance time (Referenced from RL + BL/2)	tHZ(DQS)	-	300	tCK(avg)	
DQS, DQS# differential input low pulse width	tDQSL	0.45	0.55	tCK(avg)	
DQS, DQS# differential input high pulse width	tDQSH	0.45	0.55	tCK(avg)	
DQS, DQS# rising edge to CK, CK# rising edge	tDQSS	-0.25	0.25	tCK(avg)	
DQS, DQS# falling edge setup time to CK, CK# rising edge	tDSS	0.2	-	tCK(avg)	
DQS, DQS# falling edge hold time from CK, CK# rising edge	tDSH	0.2	-	tCK(avg)	
Command and Address Timing					
DLL locking time	tDLLK	512	-	nCK	

M2F2G64CB88B7N / M2F4G64CB8HB5N
M2F2G64CB88BHN / M2F4G64CB8HB9N
2GB: 256M x 64 / 4GB: 512M x 64PC3-8500 / PC3-10600/PC-12800
Unbuffered DDR3 SDRAM DIMM



Internal READ Command to PRECHARGE Command delay	tRTP	tRTPmin.: max(4nCK, 7.5ns)	tRTPmax.: -		
Delay from start of internal write transaction to internal read command	tWTR	tWTRmin.: max(4nCK, 7.5ns)	tWTRmax.: -		
WRITE recovery time	tWR	15	-	ns	
Mode Register Set command cycle time	tMRD	4	-	nCK	
Mode Register Set command update delay	tMOD	tMODmin.: max(12nCK, 15ns)	tMODmax.: -		
ACT to internal read or write delay time	tRCD				
PRE command period	tRP				
ACT to ACT or REF command period	tRC				
CAS# to CAS# command delay	tCCD	4	-	nCK	
Auto precharge write recovery + precharge time	tDAL(min)	WR + roundup(tRP / tCK(avg))		nCK	
Multi-Purpose Register Recovery Time	tMPRR	1	-	nCK	
ACTIVE to PRECHARGE command period	tRAS	Standard Speed Bins			
ACTIVE to ACTIVE command period for 1KB page size	tRRD	max(4nCK, 7.5ns)	-		
ACTIVE to ACTIVE command period for 2KB page size	tRRD	tRRDmin.: max(4nCK, 10ns)	tRRDmax.: -		
Four activate window for 1KB page size	tFAW	37.5	-	ns	
Four activate window for 2KB page size	tFAW	50	-	ns	
Command and Address setup time to CK, CK# referenced to Vih(ac) / Vil(ac) levels	tIS(base)	125	-	ps	
Command and Address hold time from CK, CK# referenced to Vih(dc) / Vil(dc) levels	tIH(base)	200	-	ps	
Command and Address setup time to CK, CK# referenced to Vih(ac) / Vil(ac) levels	tIS(base) AC150	125+150	-	ps	
Control and Address Input pulse width for each input	tIPW	780	-	ps	
Calibration Timing					
Power-up and RESET calibration time	tZQinit	512	-	nCK	
Normal operation Full calibration time	tZQoper	256	-	nCK	
Normal operation Short calibration time	tZQCS	64	-	nCK	
Reset Timing					
Exit Reset from CKE HIGH to a valid command	tXPR	tXPRmin.: max(5nCK, tRFC(min) + 10ns)	tXPRmax.: -		
Self Refresh Timings					
Exit Self Refresh to commands not requiring a locked DLL	tXS	tXSmin.: max(5nCK, tRFC(min) + 10ns)	tXSmax.: -		
Exit Self Refresh to commands requiring a locked DLL	tXSDLL	tXSDLLmin.: tDLLK(min)	tXSDLLmax.: -	nCK	
Minimum CKE low width for Self Refresh entry to exit timing	tCKESR	tCKESRmin.: tCKE(min) + 1 nCK	tCKESRmax.: -		
Valid Clock Requirement after Self Refresh Entry (SRE) or Power-Down Entry (PDE)	tCKSRE	tCKSREmin.: max(5 nCK, 10 ns)	tCKSREmax.: -		
Valid Clock Requirement before Self Refresh Exit (SRX) or Power-Down Exit (PDX) or Reset Exit	tCKSRX	tCKSRXmin.: max(5 nCK, 10 ns)	tCKSRXmax.: -		
Power Down Timings					
Exit Power Down with DLL on to any valid command; Exit Precharge Power Down with DLL frozen to commands not requiring a locked DLL	tXP	tXPmin.: max(3nCK, 7.5ns)	tXPmax.: -		
Exit Precharge Power Down with DLL frozen to commands requiring a locked DLL	tXPDLL	tXPDLLmin.: max(10nCK, 24ns)	tXPDLLmax.: -		
CKE minimum pulse width	tCKE	tCKEmin.: max(3nCK 5.625ns)	tCKEmax.: -		
Command pass disable delay	tCPDED	tCPDEDmin.: 1	tCPDEDmin.: -	nCK	
Power Down Entry to Exit Timing	tPD	tPDmin.: tCKE(min)	tPDmax.: 9*tREFI		
Timing of ACT command to Power Down entry	tACTPDEN	tACTPDENmin.: 1	tACTPDENmax.: -	nCK	
Timing of PRE or PREA command to Power Down entry	tPRPDEN	tPRPDENmin.: 1	tPRPDENmax.: -	nCK	
Timing of RD/RDA command to Power Down entry	tRDPDEN	tRDPDENmin.: RL+4+1	tRDPDENmax.: -	nCK	

M2F2G64CB88B7N / M2F4G64CB8HB5N
M2F2G64CB88BHN / M2F4G64CB8HB9N
2GB: 256M x 64 / 4GB: 512M x 64PC3-8500 / PC3-10600/PC-12800
Unbuffered DDR3 SDRAM DIMM



Timing of WR command to Power Down entry (BL8OTF, BL8MRS, BC4OTF)	tWRPDEN	tWRPDENmin.: WL + 4 + (tWR / tCK(avg)) tWRPDENmax.: -		nCK	
Timing of WRA command to Power Down entry (BL8OTF, BL8MRS, BC4OTF)	tWRAPDEN	tWRAPDENmin.: WL+4+WR+1 tWRAPDENmax.: -		nCK	
Timing of WR command to Power Down entry (BC4MRS)	tWRPDEN	tWRPDENmin.: WL + 2 + (tWR / tCK(avg)) tWRPDENmax.: -		nCK	
Timing of WRA command to Power Down entry (BC4MRS)	tWRAPDEN	tWRAPDENmin.: WL + 2 + WR + 1 tWRAPDENmax.: -		nCK	
Timing of REF command to Power Down entry	tREFPDEN	tREFPDENmin.: 1 tREFPDENmax.: -		nCK	
Timing of MRS command to Power Down entry	tMRSPDEN	tMRSPDENmin.: tMOD(min) tMRSPDENmax.: -			
ODT Timings					
ODT high time without write command or with write command and BC4	ODTH4	ODTH4min.: 4 ODTH4max.: -		nCK	
ODT high time with Write command and BL8	ODTH8	ODTH8min.: 6 ODTH8max.: -		nCK	
Asynchronous RTT turn-on delay (Power-Down with DLL frozen)	tAONPD	2	8.5	ns	
Asynchronous RTT turn-off delay (Power-Down with DLL frozen)	tAOFPD	2	8.5	ns	
RTT turn-on	tAON	-300	300	ps	
RTT_Nom and RTT_WR turn-off time from ODTLoff reference	tAOF	0.3	0.7	tCK(avg)	
RTT dynamic change skew	tADC	0.3	0.7	tCK(avg)	
Write Leveling Timings					
First DQS/DQS# rising edge after write leveling mode is programmed	tWLMRD	40	-	nCK	
DQS/DQS# delay after write leveling mode is programmed	tWLDQSEN	25	-	nCK	
Write leveling setup time from rising CK, CK# crossing to rising DQS, DQS# crossing	tWLS	245	-	ps	
Write leveling hold time from rising DQS, DQS# crossing to rising CK, CK# crossing	tWLH	245	-	ps	
Write leveling output delay	tWLO	0	9	ns	
Write leveling output error	tWLOE	0	2	ns	

AC Timing Specifications for DDR3 SDRAM Devices Used on Module (1333MHz)

Parameter	Symbol	DDR3-1333		Units	Notes
		Min.	Max.		
Clock Timing					
Minimum Clock Cycle Time (DLL off mode)	tCK (DLL_OFF)	8	-	ns	
Average Clock Period	tCK(avg)	Refer to "Standard Speed Bins)		ps	
Average high pulse width	tCH(avg)	0.47	0.53	tCK(avg)	
Average low pulse width	tCL(avg)	0.47	0.53	tCK(avg)	
Absolute Clock Period	tCK(abs)	Min.: tCK(avg)min + tJIT(per)min Max.: tCK(avg)max + tJIT(per)max		ps	
Absolute clock HIGH pulse width	tCH(abs)	0.43	-	tCK(avg)	
Absolute clock LOW pulse width	tCL(abs)	0.43	-	tCK(avg)	
Clock Period Jitter	JIT(per)	-80	80	ps	
Clock Period Jitter during DLL locking period	JIT(per, lck)	-70	70	ps	
Cycle to Cycle Period Jitter	tJIT(cc)	160	160	ps	
Cycle to Cycle Period Jitter during DLL locking period	JIT(cc, lck)	140	140	ps	
Duty Cycle Jitter	tJIT(duty)	-	-	ps	
Cumulative error across 2 cycles	tERR(2per)	-118	118	ps	
Cumulative error across 3 cycles	tERR(3per)	-140	140	ps	
Cumulative error across 4 cycles	tERR(4per)	-155	155	ps	
Cumulative error across 5 cycles	tERR(5per)	-168	168	ps	
Cumulative error across 6 cycles	tERR(6per)	-177	177	ps	
Cumulative error across 7 cycles	tERR(7per)	-186	186	ps	
Cumulative error across 8 cycles	tERR(8per)	-193	193	ps	
Cumulative error across 9 cycles	tERR(9per)	-200	200	ps	
Cumulative error across 10 cycles	tERR(10per)	-205	205	ps	
Cumulative error across 11 cycles	tERR(11per)	-210	210	ps	
Cumulative error across 12 cycles	tERR(12per)	-215	215	ps	
Cumulative error across n = 13, 14 . . . 49, 50 cycles	tERR(nper)	tERR(nper)min = (1 + 0.68ln(n)) * tJIT(per)min tERR(nper)max = (1 + 0.68ln(n)) * tJIT(per)max		ps	
Data Timing					
DQS, DQS# to DQ skew, per group, per access	tDQSQ	-	125	ps	
DQ output hold time from DQS, DQS#	tQH	0.38	-	tCK(avg)	
DQ low-impedance time from CK, CK#	tLZ(DQ)	-500	250	ps	
DQ high impedance time from CK, CK#	tHZ(DQ)	-	250	ps	
Data setup time to DQS, DQS# referenced to Vih(ac) / Vil(ac) levels	tDS(base) AC175	-		ps	
Data setup time to DQS, DQS# referenced to Vih(ac) / Vil(ac) levels	tDS(base) AC150	30		ps	
Data hold time from DQS, DQS# referenced to Vih(dc) / Vil(dc) levels	tDH(base) DC100	65		ps	
DQ and DM Input pulse width for each input	tDIPW	400	-	ps	
Data Strobe Timing					
DQS,DQS# differential READ Preamble	tRPRE	0.9	Note 19	tCK(avg)	
DQS, DQS# differential READ Postamble	tRPST	0.3	Note 11	tCK(avg)	
DQS, DQS# differential output high time	tQSH	0.4	-	tCK(avg)	
DQS, DQS# differential output low time	tQSL	0.4	-	tCK(avg)	
DQS, DQS# differential WRITE Preamble	tWPRE	0.9	-	tCK(avg)	
DQS, DQS# differential WRITE Postamble	tWPST	0.3	-	tCK(avg)	
DQS, DQS# rising edge output access time from rising CK, CK#	tDQSCK	-255	255	tCK(avg)	
DQS and DQS# low-impedance time (Referenced from RL - 1)	tLZ(DQS)	-500	250	tCK(avg)	
DQS and DQS# high-impedance time (Referenced from RL + BL/2)	tHZ(DQS)	-	250	tCK(avg)	
DQS, DQS# differential input low pulse width	tDQSL	0.45	0.55	tCK(avg)	
DQS, DQS# differential input high pulse width	tDQSH	0.45	0.55	tCK(avg)	
DQS, DQS# rising edge to CK, CK# rising edge	tDQSS	-0.25	0.25	tCK(avg)	
DQS, DQS# falling edge setup time to CK, CK# rising edge	tDSS	0.2	-	tCK(avg)	
DQS, DQS# falling edge hold time from CK, CK# rising edge	tDSH	0.2	-	tCK(avg)	
Command and Address Timing					

M2F2G64CB88B7N / M2F4G64CB8HB5N
M2F2G64CB88BHN / M2F4G64CB8HB9N
2GB: 256M x 64 / 4GB: 512M x 64PC3-8500 / PC3-10600/PC-12800
Unbuffered DDR3 SDRAM DIMM



DLL locking time	tDLLK	512	-	nCK	
Internal READ Command to PRECHARGE Command delay	tRTP	tRTPmin.: max(4nCK, 7.5ns) tRTPmax.: -			
Delay from start of internal write transaction to internal read command	tWTR	tWTRmin.: max(4nCK, 7.5ns) tWTRmax.:			
WRITE recovery time	tWR	15	-	ns	
Mode Register Set command cycle time	tMRD	4	-	nCK	
Mode Register Set command update delay	tMOD	tMODmin.: max(12nCK, 15ns) tMODmax.:			
ACT to internal read or write delay time	tRCD				
PRE command period	tRP				
ACT to ACT or REF command period	tRC				
CAS# to CAS# command delay	tCCD	4		nCK	
Auto precharge write recovery + precharge time	tDAL(min)	WR + roundup(tRP / tCK(avg))		nCK	
Multi-Purpose Register Recovery Time	tMPRR	1	-	nCK	
ACTIVE to PRECHARGE command period	tRAS	Standard Speed Bins			
ACTIVE to ACTIVE command period for 1KB page size	tRRD	tRRDmin.: max(4nCK, 6ns) tRRDmax.:			
ACTIVE to ACTIVE command period for 2KB page size	tRRD	tRRDmin.: max(4nCK, 7.5ns) tRRDmax.:			
Four activate window for 1KB page size	tFAW	30	0	ns	
Four activate window for 2KB page size	tFAW	45	0	ns	
Command and Address setup time to CK, CK# referenced to Vih(ac) / Vil(ac) levels	tIS(base)	65	-	ps	
Command and Address hold time from CK, CK# referenced to Vih(dc) / Vil(dc) levels	tIH(base)	140	-	ps	
Command and Address setup time to CK, CK# referenced to Vih(ac) / Vil(ac) levels	tIS(base) AC150	65+125	-	ps	
Control and Address Input pulse width for each input	tIPW	620	-	ps	
Calibration Timing					
Power-up and RESET calibration time	tZQinit	512	-	nCK	
Normal operation Full calibration time	tZQoper	256	-	nCK	
Normal operation Short calibration time	tZQCS	64	-	nCK	
Reset Timing					
Exit Reset from CKE HIGH to a valid command	tXPR	tXPRmin.: max(5nCK, tRFC(min) + 10ns) tXPRmax.: -			
Self Refresh Timings					
Exit Self Refresh to commands not requiring a locked DLL	tXS	tXSmin.: max(5nCK, tRFC(min) + 10ns) tXSmax.: -			
Exit Self Refresh to commands requiring a locked DLL	tXSDLL	tXSDLLmin.: tDLLK(min) tXSDLLmax.: -		nCK	
Minimum CKE low width for Self Refresh entry to exit timing	tCKESR	tCKESRmin.: tCKE(min) + 1 nCK tCKESRmax.: -			
Valid Clock Requirement after Self Refresh Entry (SRE) or Power-Down Entry (PDE)	tCKSRE	tCKSREmin.: max(5 nCK, 10 ns) tCKSREmax.: -			
Valid Clock Requirement before Self Refresh Exit (SRX) or Power-Down Exit (PDX) or Reset Exit	tCKSRX	tCKSRXmin.: max(5 nCK, 10 ns) tCKSRXmax.: -			
Power Down Timings					
Exit Power Down with DLL on to any valid command; Exit Precharge Power Down with DLL frozen to commands not requiring a locked DLL	tXP	tXPmin.: max(3nCK, 6ns) tXPmax.: -			
Exit Precharge Power Down with DLL frozen to commands requiring a locked DLL	tXPDLL	tXPDLLmin.: max(10nCK, 24ns) tXPDLLmax.: -			
CKE minimum pulse width	tCKE	tCKEmin.: max(3nCK, 5.625ns) tCKEmin.: -			
Command pass disable delay	tCPDED	tCPDEDmin.: 1 tCPDEDmin.: -		nCK	
Power Down Entry to Exit Timing	tPD	tPDmin.: tCKE(min) tPDmax.: 9*tREFI			
Timing of ACT command to Power Down entry	tACTPDEN	tACTPDENmin.: 1 tACTPDENmax.: -		nCK	
Timing of PRE or PREA command to Power Down entry	tPRPDEN	tPRPDENmin.: 1		nCK	

M2F2G64CB88B7N / M2F4G64CB8HB5N
M2F2G64CB88BHN / M2F4G64CB8HB9N
2GB: 256M x 64 / 4GB: 512M x 64PC3-8500 / PC3-10600/PC-12800
Unbuffered DDR3 SDRAM DIMM



		tPRPDENmax.: -			
Timing of RD/RDA command to Power Down entry	tRDPDEN	tRDPDENmin.: RL+4+1 tRDPDENmax.: -		nCK	
Timing of WR command to Power Down entry (BL8OTF, BL8MRS, BC4OTF)	tWRPDEN	tWRPDENmin.: WL + 4 + (tWR / tCK(avg)) tWRPDENmax.: -		nCK	
Timing of WRA command to Power Down entry (BL8OTF, BL8MRS, BC4OTF)	tWRAPDEN	tWRAPDENmin.: WL+4+WR+1 tWRAPDENmax.: -		nCK	
Timing of WR command to Power Down entry (BC4MRS)	tWRPDEN	tWRPDENmin.: WL + 2 + (tWR / tCK(avg)) tWRPDENmax.: -		nCK	
Timing of WRA command to Power Down entry (BC4MRS)	tWRAPDEN	tWRAPDENmin.: WL + 2 +WR + 1 tWRAPDENmax.: -		nCK	
Timing of REF command to Power Down entry	tREFPDEN	tREFPDENmin.: 1 tREFPDENmax.: -		nCK	
Timing of MRS command to Power Down entry	tMRSPDEN	tMRSPDENmin.: tMOD(min) tMRSPDENmax.: -			
ODT Timings					
ODT high time without write command or with write command and BC4	ODTH4	ODTH4min.: 4 ODTH4max.: -		nCK	
ODT high time with Write command and BL8	ODTH8	ODTH8min.: 6 ODTH8max.: -		nCK	
Asynchronous RTT turn-on delay (Power-Down with DLL frozen)	tAONPD	2	8.5	ns	
Asynchronous RTT turn-off delay (Power-Down with DLL frozen)	tAOFPD	2	8.5	ns	
RTT turn-on	tAON	-250	250	ps	
RTT_Nom and RTT_WR turn-off time from ODTLoff reference	tAOF	0.3	0.7	tCK(avg)	
RTT dynamic change skew	tADC	0.3	0.7	tCK(avg)	
Write Leveling Timings					
First DQS/DQS# rising edge after write leveling mode is programmed	tWLMRD	40	-	nCK	
DQS/DQS# delay after write leveling mode is programmed	tWLDQSEN	25	-	nCK	
Write leveling setup time from rising CK, CK# crossing to rising DQS, DQS# crossing	tWLS	195	-	ps	
Write leveling hold time from rising DQS, DQS# crossing to rising CK, CK# crossing	tWLH	195	-	ps	
Write leveling output delay	tWLO	0	9	ns	
Write leveling output error	tWLOE	0	2	ns	

AC Timing Specifications for DDR3 SDRAM Devices Used on Module (1600MHz)

Parameter	Symbol	DDR3-1600		Units	Notes
		Min.	Max.		
Clock Timing					
Minimum Clock Cycle Time (DLL off mode)	tCK (DLL_OFF)	8	-	ns	
Average Clock Period	tCK(avg)	Refer to "Standard Speed Bins)		ps	
Average high pulse width	tCH(avg)	0.47	0.53	tCK(avg)	
Average low pulse width	tCL(avg)	0.47	0.53	tCK(avg)	
Absolute Clock Period	tCK(abs)	Min.: tCK(avg)min + tJIT(per)min Max.: tCK(avg)max + tJIT(per)max		ps	
Absolute clock HIGH pulse width	tCH(abs)	0.43	-	tCK(avg)	
Absolute clock LOW pulse width	tCL(abs)	0.43	-	tCK(avg)	
Clock Period Jitter	JIT(per)	-70	70	ps	
Clock Period Jitter during DLL locking period	JIT(per, lck)	-60	60	ps	
Cycle to Cycle Period Jitter	tJIT(cc)	140	140	ps	
Cycle to Cycle Period Jitter during DLL locking period	JIT(cc, lck)	120	120	ps	
Duty Cycle Jitter	tJIT(duty)	-	-	ps	
Cumulative error across 2 cycles	tERR(2per)	-103	103	ps	
Cumulative error across 3 cycles	tERR(3per)	-122	122	ps	
Cumulative error across 4 cycles	tERR(4per)	-136	136	ps	
Cumulative error across 5 cycles	tERR(5per)	-147	147	ps	
Cumulative error across 6 cycles	tERR(6per)	-155	155	ps	
Cumulative error across 7 cycles	tERR(7per)	-163	163	ps	
Cumulative error across 8 cycles	tERR(8per)	-169	169	ps	
Cumulative error across 9 cycles	tERR(9per)	-175	175	ps	
Cumulative error across 10 cycles	tERR(10per)	-180	180	ps	
Cumulative error across 11 cycles	tERR(11per)	-184	184	ps	
Cumulative error across 12 cycles	tERR(12per)	-188	188	ps	
Cumulative error across n = 13, 14 . . . 49, 50 cycles	tERR(nper)	tERR(nper)min = (1 + 0.68ln(n)) * tJIT(per)min tERR(nper)max = (1 + 0.68ln(n)) * tJIT(per)max		ps	
Data Timing					
DQS, DQS# to DQ skew, per group, per access	tDQSQ	-	100	ps	
DQ output hold time from DQS, DQS#	tQH	0.38	-	tCK(avg)	
DQ low-impedance time from CK, CK#	tLZ(DQ)	-450	225	ps	
DQ high impedance time from CK, CK#	tHZ(DQ)	-	225	ps	
Data setup time to DQS, DQS# referenced to Vih(ac) / Vil(ac) levels	tDS(base) AC175	-		ps	
Data setup time to DQS, DQS# referenced to Vih(ac) / Vil(ac) levels	tDS(base) AC150	10		ps	
Data hold time from DQS, DQS# referenced to Vih(dc) / Vil(dc) levels	tDH(base) DC100	45		ps	
DQ and DM Input pulse width for each input	tDIPW	360	-	ps	
Data Strobe Timing					
DQS, DQS# differential READ Preamble	tRPRE	0.9	Note 19	tCK(avg)	
DQS, DQS# differential READ Postamble	tRPST	0.3	Note 11	tCK(avg)	
DQS, DQS# differential output high time	tQSH	0.4	-	tCK(avg)	
DQS, DQS# differential output low time	tQSL	0.4	-	tCK(avg)	
DQS, DQS# differential WRITE Preamble	tWPRE	0.9	-	tCK(avg)	
DQS, DQS# differential WRITE Postamble	tWPST	0.3	-	tCK(avg)	
DQS, DQS# rising edge output access time from rising CK, CK#	tDQSCK	-255	255	tCK(avg)	
DQS and DQS# low-impedance time (Referenced from RL - 1)	tLZ(DQS)	-450	225	tCK(avg)	
DQS and DQS# high-impedance time (Referenced from RL + BL/2)	tHZ(DQS)	-	225	tCK(avg)	
DQS, DQS# differential input low pulse width	tDQSL	0.45	0.55	tCK(avg)	
DQS, DQS# differential input high pulse width	tDQSH	0.45	0.55	tCK(avg)	
DQS, DQS# rising edge to CK, CK# rising edge	tDQSS	-0.27	0.27	tCK(avg)	
DQS, DQS# falling edge setup time to CK, CK# rising edge	tDSS	0.18	-	tCK(avg)	
DQS, DQS# falling edge hold time from CK, CK# rising edge	tDSH	0.18	-	tCK(avg)	
Command and Address Timing					

M2F2G64CB88B7N / M2F4G64CB8HB5N
M2F2G64CB88BHN / M2F4G64CB8HB9N
2GB: 256M x 64 / 4GB: 512M x 64PC3-8500 / PC3-10600/PC-12800
Unbuffered DDR3 SDRAM DIMM



DLL locking time	tDLLK	512	-	nCK	
Internal READ Command to PRECHARGE Command delay	tRTP	tRTPmin.: max(4nCK, 7.5ns) tRTPmax.: -			
Delay from start of internal write transaction to internal read command	tWTR	tWTRmin.: max(4nCK, 7.5ns) tWTRmax.:			
WRITE recovery time	tWR	15	-	ns	
Mode Register Set command cycle time	tMRD	4	-	nCK	
Mode Register Set command update delay	tMOD	tMODmin.: max(12nCK, 15ns) tMODmax.:			
ACT to internal read or write delay time	tRCD				
PRE command period	tRP				
ACT to ACT or REF command period	tRC				
CAS# to CAS# command delay	tCCD	4		nCK	
Auto precharge write recovery + precharge time	tDAL(min)	WR + roundup(tRP / tCK(avg))		nCK	
Multi-Purpose Register Recovery Time	tMPRR	1	-	nCK	
ACTIVE to PRECHARGE command period	tRAS	Standard Speed Bins			
ACTIVE to ACTIVE command period for 1KB page size	tRRD	tRRDmin.: max(4nCK, 6ns) tRRDmax.:			
ACTIVE to ACTIVE command period for 2KB page size	tRRD	tRRDmin.: max(4nCK, 7.5ns) tRRDmax.:			
Four activate window for 1KB page size	tFAW	30	-	ns	
Four activate window for 2KB page size	tFAW	40	-	ns	
Command and Address setup time to CK, CK# referenced to Vih(ac) / Vil(ac) levels	tIS(base)	45	-	ps	
Command and Address hold time from CK, CK# referenced to Vih(dc) / Vil(dc) levels	tIH(base)	120	-	ps	
Command and Address setup time to CK, CK# referenced to Vih(ac) / Vil(ac) levels	tIS(base) AC150	170	-	ps	
Control and Address Input pulse width for each input	tIPW	560	-	ps	
Calibration Timing					
Power-up and RESET calibration time	tZQinit	512	-	nCK	
Normal operation Full calibration time	tZQoper	256	-	nCK	
Normal operation Short calibration time	tZQCS	64	-	nCK	
Reset Timing					
Exit Reset from CKE HIGH to a valid command	tXPR	tXPRmin.: max(5nCK, tRFC(min) + 10ns) tXPRmax.: -			
Self Refresh Timings					
Exit Self Refresh to commands not requiring a locked DLL	tXS	tXSmin.: max(5nCK, tRFC(min) + 10ns) tXSmax.: -			
Exit Self Refresh to commands requiring a locked DLL	tXSDLL	tXSDLLmin.: tDLLK(min) tXSDLLmax.: -		nCK	
Minimum CKE low width for Self Refresh entry to exit timing	tCKESR	tCKESRmin.: tCKE(min) + 1 nCK tCKESRmax.: -			
Valid Clock Requirement after Self Refresh Entry (SRE) or Power-Down Entry (PDE)	tCKSRE	tCKSREmin.: max(5 nCK, 10 ns) tCKSREmax.: -			
Valid Clock Requirement before Self Refresh Exit (SRX) or Power-Down Exit (PDX) or Reset Exit	tCKSRX	tCKSRXmin.: max(5 nCK, 10 ns) tCKSRXmax.: -			
Power Down Timings					
Exit Power Down with DLL on to any valid command; Exit Precharge Power Down with DLL frozen to commands not requiring a locked DLL	tXP	tXPmin.: max(3nCK, 6ns) tXPmax.: -			
Exit Precharge Power Down with DLL frozen to commands requiring a locked DLL	tXPDLL	tXPDLLmin.: max(10nCK, 24ns) tXPDLLmax.: -			
CKE minimum pulse width	tCKE	tCKEmin.: max(3nCK, 5ns) tCKEmax.: -			
Command pass disable delay	tCPDED	tCPDEDmin.: 1 tCPDEDmin.: -		nCK	
Power Down Entry to Exit Timing	tPD	tPDmin.: tCKE(min) tPDmax.: 9*tREFI			
Timing of ACT command to Power Down entry	tACTPDEN	tACTPDENmin.: 1 tACTPDENmax.: -		nCK	
Timing of PRE or PREA command to Power Down entry	tPRPDEN	tPRPDENmin.: 1		nCK	

M2F2G64CB88B7N / M2F4G64CB8HB5N
M2F2G64CB88BHN / M2F4G64CB8HB9N
2GB: 256M x 64 / 4GB: 512M x 64PC3-8500 / PC3-10600/PC-12800
Unbuffered DDR3 SDRAM DIMM



		tPRPDENmax.: -			
Timing of RD/RDA command to Power Down entry	tRDPDEN	tRDPDENmin.: RL+4+1 tRDPDENmax.: -		nCK	
Timing of WR command to Power Down entry (BL8OTF, BL8MRS, BC4OTF)	tWRPDEN	tWRPDENmin.: WL + 4 + (tWR / tCK(avg)) tWRPDENmax.: -		nCK	
Timing of WRA command to Power Down entry (BL8OTF, BL8MRS, BC4OTF)	tWRAPDEN	tWRAPDENmin.: WL+4+WR+1 tWRAPDENmax.: -		nCK	
Timing of WR command to Power Down entry (BC4MRS)	tWRPDEN	tWRPDENmin.: WL + 2 + (tWR / tCK(avg)) tWRPDENmax.: -		nCK	
Timing of WRA command to Power Down entry (BC4MRS)	tWRAPDEN	tWRAPDENmin.: WL + 2 +WR + 1 tWRAPDENmax.: -		nCK	
Timing of REF command to Power Down entry	tREFPDEN	tREFPDENmin.: 1 tREFPDENmax.: -		nCK	
Timing of MRS command to Power Down entry	tMRSPDEN	tMRSPDENmin.: tMOD(min) tMRSPDENmax.: -			
ODT Timings					
ODT high time without write command or with write command and BC4	ODTH4	ODTH4min.: 4 ODTH4max.: -		nCK	
ODT high time with Write command and BL8	ODTH8	ODTH8min.: 6 ODTH8max.: -		nCK	
Asynchronous RTT turn-on delay (Power-Down with DLL frozen)	tAONPD	2	8.5	ns	
Asynchronous RTT turn-off delay (Power-Down with DLL frozen)	tAOFPD	2	8.5	ns	
RTT turn-on	tAON	-225	225	ps	
RTT_Nom and RTT_WR turn-off time from ODTLoff reference	tAOF	0.3	0.7	tCK(avg)	
RTT dynamic change skew	tADC	0.3	0.7	tCK(avg)	
Write Leveling Timings					
First DQS/DQS# rising edge after write leveling mode is programmed	tWLMRD	40	-	nCK	
DQS/DQS# delay after write leveling mode is programmed	tWLDQSEN	25	-	nCK	
Write leveling setup time from rising CK, CK# crossing to rising DQS, DQS# crossing	tWLS	165	-	ps	
Write leveling hold time from rising DQS, DQS# crossing to rising CK, CK# crossing	tWLH	165	-	ps	
Write leveling output delay	tWLO	0	7.5	ns	
Write leveling output error	tWLOE	0	2	ns	

Package Dimensions

[M2F(X)2G64CB88B7N, 2GB – 1 Rank, 256Mx8 DDR3 SDRAMs]

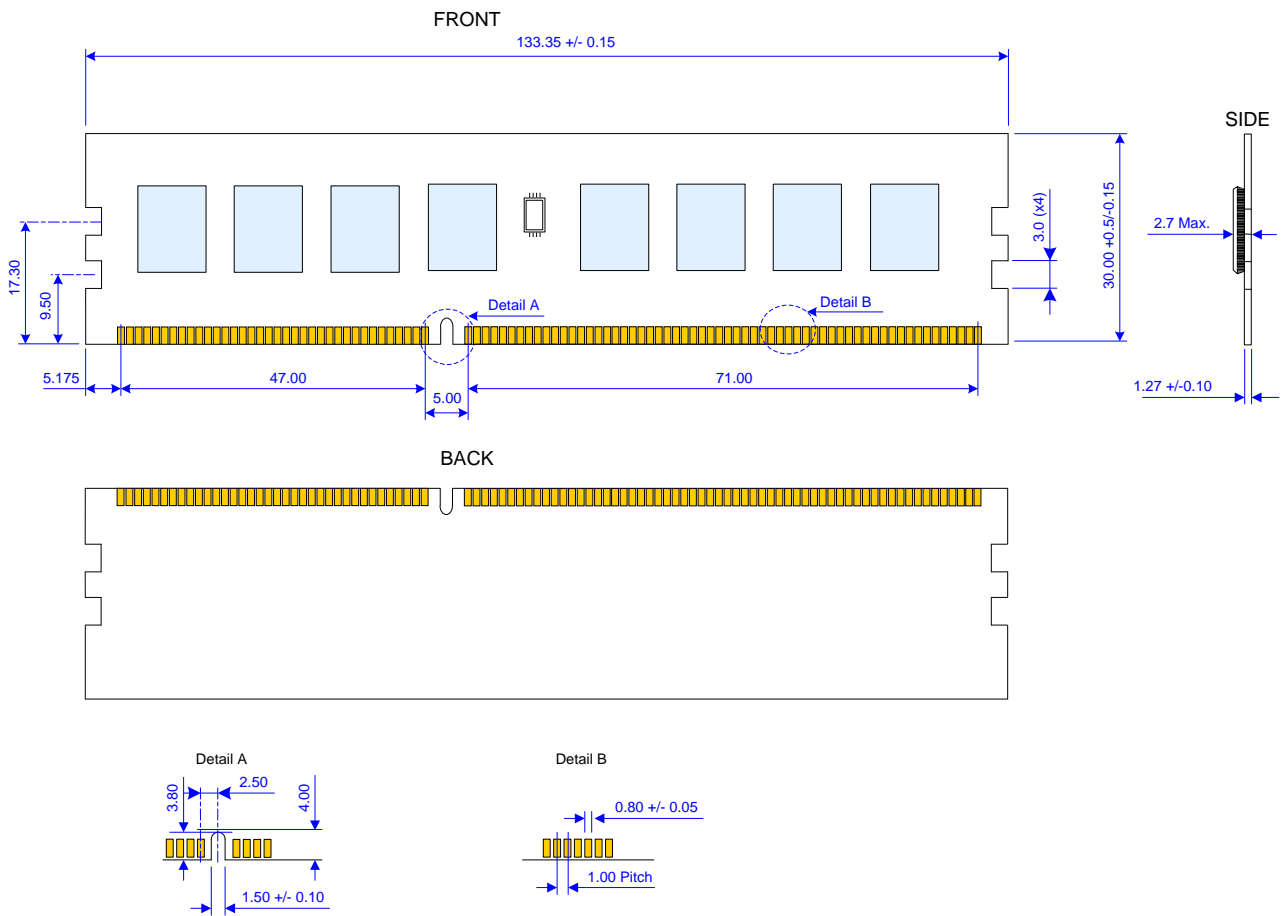

Units: Millimeters

**M2F2G64CB88B7N / M2F4G64CB8HB5N
M2F2G64CB88BHN / M2F4G64CB8HB9N
2GB: 256M x 64 / 4GB: 512M x 64PC3-8500 / PC3-10600/PC-12800
Unbuffered DDR3 SDRAM DIMM**



[M2F2G64CB88BHN, 2GB – 1 Rank, 256Mx8 DDR3 SDRAMs]

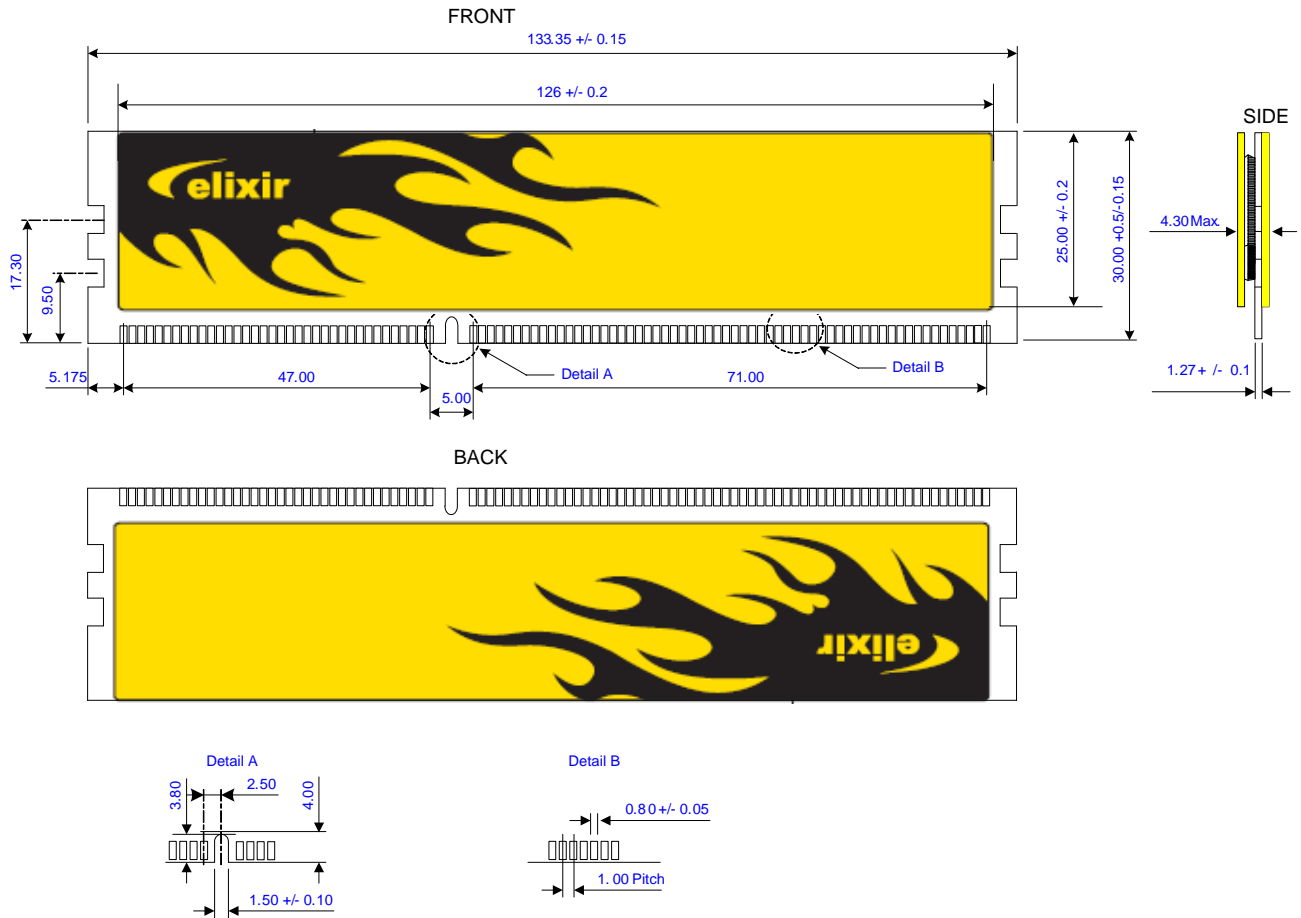

Units: Millimeters

**M2F2G64CB88B7N / M2F4G64CB8HB5N
M2F2G64CB88BHN / M2F4G64CB8HB9N
2GB: 256M x 64 / 4GB: 512M x 64 PC3-8500 / PC3-10600/PC-12800
Unbuffered DDR3 SDRAM DIMM**



[M2F4G64CB8HB9N, 4GB – 2 Ranks, 256Mx8 DDR3 SDRAMs]

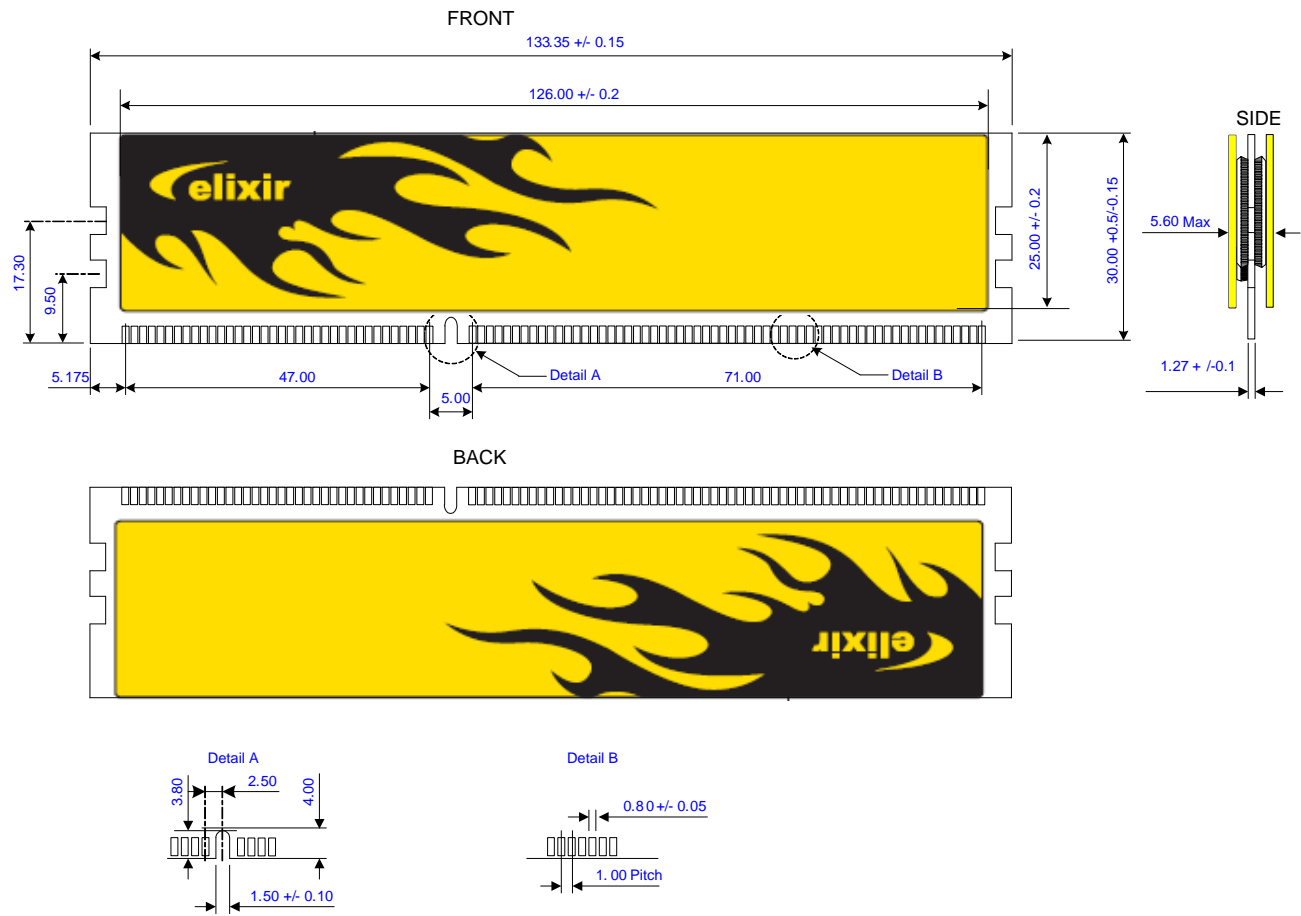

Units: Millimeters

M2F2G64CB88B7N / M2F4G64CB8HB5N
M2F2G64CB88BHN / M2F4G64CB8HB9N
2GB: 256M x 64 / 4GB: 512M x 64PC3-8500 / PC3-10600/PC-12800
Unbuffered DDR3 SDRAM DIMM



Revision Log

Rev	Date	Modification
0.1	01/2010	Preliminary Release
0.5	05/2010	Preliminary Release 2
1.0	06/2010	Official Release
1.1	10/2010	Revision Update (Re-move Over-Clocking Products)