

Doc. Number :

- Tentative Specification
- Preliminary Specification
- Approval Specification

MODEL NO.: M315DJJ
SUFFIX: K30

Customer:

APPROVED BY

SIGNATURE

Name / Title _____

Note

Product Version B1

Please return 1 copy for your confirmation with your signature and comments.

Approved By	Checked By	Prepared By
梁永祥	陳立錚	江乃瑩

CONTENTS

1. GENERAL DESCRIPTION	5
1.1 OVERVIEW	5
1.2 GENERAL SPECIFICATIONS	5
2. MECHANICAL SPECIFICATIONS	6
3. ABSOLUTE MAXIMUM RATINGS	6
3.1 ABSOLUTE RATINGS OF ENVIRONMENT	6
3.2 ELECTRICAL ABSOLUTE RATINGS	7
3.2.1 TFT LCD MODULE	7
3.2.2 BACKLIGHT UNIT	7
4. ELECTRICAL SPECIFICATIONS	7
4.1 FUNCTION BLOCK DIAGRAM	7
4.2. INTERFACE CONNECTIONS	8
4.3 ELECTRICAL CHARACTERISTICS	10
4.3.1 LCD ELETRONICS SPECIFICATION	10
4.3.2.BACKLIGHT UNIT	12
4.3.3 LIGHTBAR CONNECTOR PIN ASSIGNMENT:	12
4.4 V BY ONE INPUT SIGNAL SPECIFICATIONS	14
4.4.1 V BY ONE DATA MAPPING TABLE	14
4.4.2 COLOR DATA INPUT ASSIGNMENT	15
4.5 DISPLAY TIMING SPECIFICATIONS	16
4.6 V BY ONE INPUT SIGNAL TIMING DIAGRAM	18
4.7 BYTE LENGTH AND COLOR MAPPING OF V-BY-ONE HS	19
4.8 POWER ON/OFF SEQUENCE	20
5. OPTICAL CHARACTERISTICS	22
5.1 TEST CONDITIONS	22
5.2 OPTICAL SPECIFICATIONS	22
6. RELIABILITY TEST ITEM	25
7. MECHANICAL STRENGTH CHARACTERISTICS	26
7.1 MECHANICAL STRENGTH SPECIFICATIONS	26
7.2 TEST CONDITIONS	26
7.3 DEFINITION OF TEST POINTS	26
8. PACKING	27
8.1 PACKING SPECIFICATIONS	27
8.2 PACKING METHOD	27
8.3 PALLET	28

8.4 UN-PACKING METHOD	29
9. INX MODULE LABEL	30
10. PRECAUTIONS	31
10.1 ASSEMBLY AND HANDLING PRECAUTIONS	31
10.2 STORAGE PRECAUTIONS	31
10.3 OPERATION PRECAUTIONS	32
10.4 SAFETY PRECAUTIONS	32
10.5 SAFETY STANDARDS	32
10.6 OTHER	32
Appendix 1. SYSTEM COVER DESIGN NOTICE	33
Appendix 2. OUTLINE DRAWING	36

REVISION HISTORY

Version	Date	Page	Description
0.0	Sep.,04 , 2014	All	Tentative Spec Ver.0.0 was first issued.
1.0	Mar.,16 , 2015	All	Preliminary Spec Ver.1.0 was first issued.

1. GENERAL DESCRIPTION

1.1 OVERVIEW

M315DJJ-K30 is a 31.5" TFT Liquid Crystal Display MNT module with WLED Backlight unit and 51 pins 8 lane – V by 1 interface. This module supports 3840 x 2160 UHD(Ultra High Definition) mode and can display up to 1.073G colors. The converter module for Backlight is not built in.

1.2 GENERAL SPECIFICATIONS

Item	Specification	Unit	Note
Screen Size	31.5" real diagonal	mm	
Driver Element	a-si TFT active matrix	-	-
Pixel Number	3840 x R.G.B. x 2160	pixel	-
Pixel Pitch	0.181 (H) x 0.181 (V)	mm	-
Pixel Arrangement	RGB vertical stripe	-	-
Display Colors	1.073G	color	-
Transmissive Mode	Normally Black	-	-
Surface Treatment	AG type, 3H hard coating, Haze 25	-	-
Color Gamut	95% of NTSC(Typ.)	-	-
RoHS, Halogen Free & TCO 6.0	RoHS, Halogen Free TCO 6.0 compliance		
Luminance, White	300	Cd/m2	
Power Consumption	Total (40.58) W(Typ.) @ cell (14.11) W(Typ.), BL (26.47)W(Typ.)		(1)

Note (1) The specified power consumption : Total= cell (reference 4.3.1)+BL (reference 4.3.3)

Note (2)

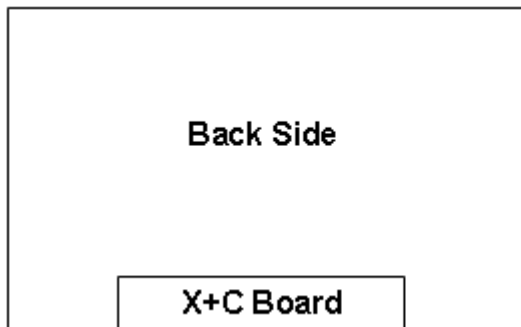

2. MECHANICAL SPECIFICATIONS

Item	Min.	Typ.	Max.	Unit	Note	
Module Size	Horizontal (H)	716.4	717.4	718.4	mm	(1)
	Vertical (V)	412.85	413.85	414.85	mm	
	Thickness (T)	16.9	17.9	18.9	mm	
Bezel Area	Horizontal	702.4	703.4	704.4	mm	
	Vertical	396.85	397.85	398.85	mm	
Active Area	Horizontal	-	698.4	-	mm	
	Vertical	-	392.85	-	mm	
Weight	3287	3460	3633	g		

Note (1) Please refer to the attached drawings for more information of front and back outline dimensions.

3. ABSOLUTE MAXIMUM RATINGS

3.1 ABSOLUTE RATINGS OF ENVIRONMENT

Item	Symbol	Value		Unit	Note
		Min.	Max.		
Storage Temperature	TST	-20	60	°C	(1)
Operating Ambient Temperature	TOP	0	50	°C	(1), (2)

Note (1)

(a) 90 %RH Max..

(b) Wet-bulb temperature should be 39 °C Max.

(c) No condensation.

Note (2) Panel surface temperature should be 0°C min. and 65°C max under Vcc=5.0V, fr =60Hz, typical LED string current, 25°C ambient temperature, and no humidity control . Any condition of ambient operating temperature ,the surface of active area should be keeping not higher than 65°C.

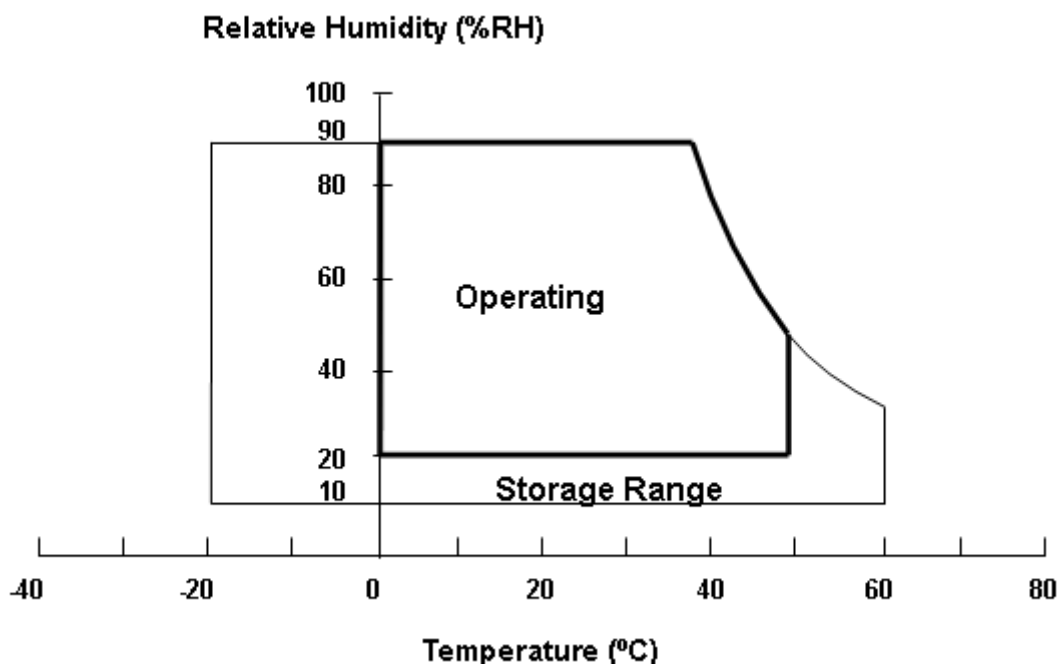

3.2 ELECTRICAL ABSOLUTE RATINGS

3.2.1 TFT LCD MODULE

Item	Symbol	Value		Unit	Note
		Min.	Max.		
Power Supply Voltage	VCCS	-0.3	13.5.	V	(1)
Logic Input Voltage	VIN	-0.3	3.6	V	

3.2.2 BACKLIGHT UNIT

Item	Symbol	Value			Unit	Note
		Min.	Typ	Max.		
LED Forward Current Per Input Pin	IF	(103.4)	110	(116.6)	mA	(1), (2) Duty=100%

Note (1) Permanent damage to the device may occur if maximum values are exceeded. Function operation should be restricted to the conditions described under Normal Operating Conditions.

Note (2) Specified values are for input pin of LED light bar at $T_a=25\pm 2\text{ }^\circ\text{C}$ (Refer to 4.3.3 and 4.3.4 for further information).

4. ELECTRICAL SPECIFICATIONS

4.1 FUNCTION BLOCK DIAGRAM

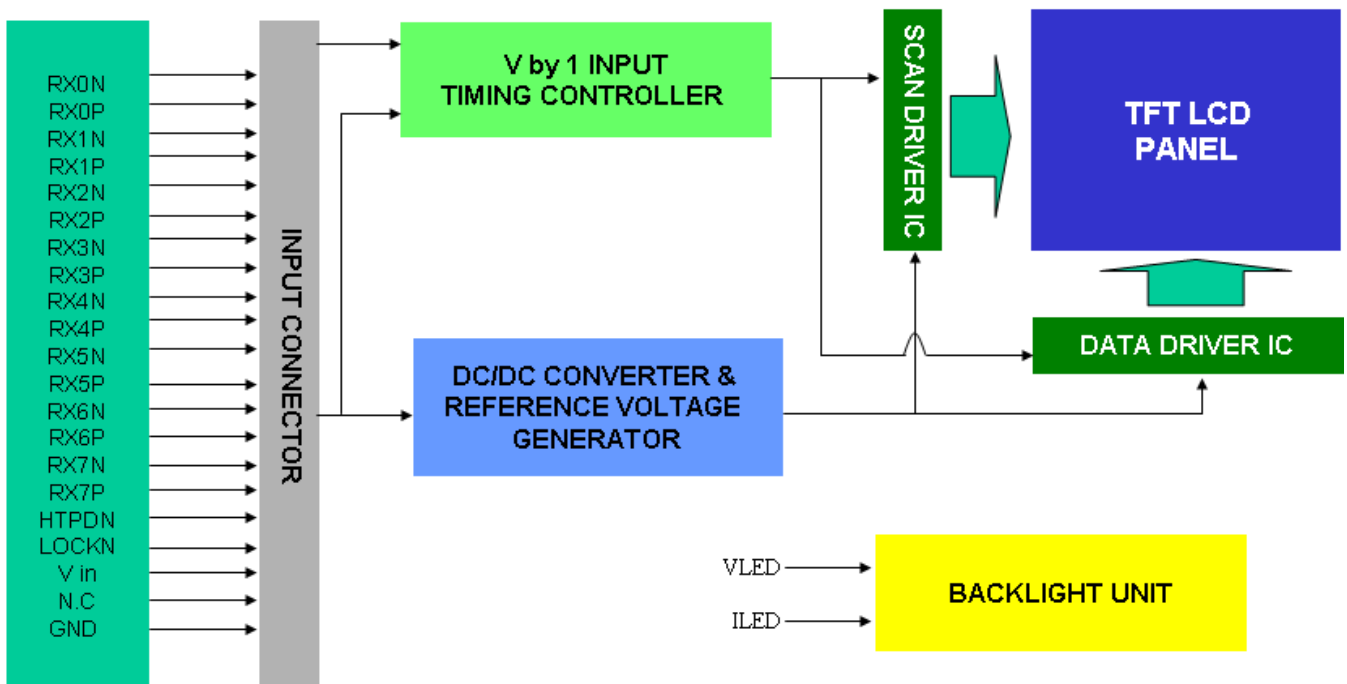

4.2. INTERFACE CONNECTIONS

PIN ASSIGNMENT

Pin	Name	Description	Note
1	Vin	Power input (+12V)	
2	Vin	Power input (+12V)	
3	Vin	Power input (+12V)	
4	Vin	Power input (+12V)	
5	Vin	Power input (+12V)	
6	Vin	Power input (+12V)	
7	Vin	Power input (+12V)	
8	Vin	Power input (+12V)	
9	N.C.	No Connection	(2)
10	GND	Ground	
11	GND	Ground	
12	GND	Ground	
13	GND	Ground	
14	GND	Ground	
15	N.C.	No Connection	(2)
16	N.C.	No Connection	(2)
17	N.C.	No Connection	(2)
18	N.C	For internal use, no connection	
19	N.C	For internal use, no connection	
20	N.C.	No Connection	(2)
21	N.C.	No Connection	(2)
22	N.C.	No Connection	(2)
23	N.C.	No Connection	(2)
24	N.C.	No Connection	(2)
25	HTPDN	Hot plug detect output, Open drain.	
26	LOCKN	Lock detect output, Open drain.	
27	GND	Ground	
28	RX0N	1 st Pixel Negative VbyOne differential data input in area A. Lan 0	(1)
29	RX0P	1 st Pixel Positive VbyOne differential data input in area A. Lan 0	
30	GND	Ground	
31	RX1N	2 nd Pixel Negative VbyOne differential data input in area A. Lan 1	(1)
32	RX1P	2 nd Pixel Positive VbyOne differential data input in area A. Lan 1	
33	GND	Ground	
34	RX2N	3 rd Pixel Negative VbyOne differential data input in area A. Lan 2	(1)
35	RX2P	3 rd Pixel Positive VbyOne differential data input in area A. Lan 2	
36	GND	Ground	
37	RX3N	4 th Pixel Negative VbyOne differential data input in area A. Lan 3	(1)
38	RX3P	4 th Pixel Positive VbyOne differential data input in area A. Lan 3	
39	GND	Ground	
40	RX4N	5 th Pixel Negative VbyOne differential data input in area A. Lan 4	(1)
41	RX4P	5 th Pixel Positive VbyOne differential data input in area A. Lan 4	
42	GND	Ground	
43	RX5N	6 th Pixel Negative VbyOne differential data input in area A. Lan 5	(1)
44	RX5P	6 th Pixel Positive VbyOne differential data input in area A. Lan 5	
45	GND	Ground	
46	RX6N	7 th Pixel Negative VbyOne differential data input in area A. Lan 6	(1)
47	RX6P	7 th Pixel Positive VbyOne differential data input in area A. Lan 6	
48	GND	Ground	

Pin	Name	Description	Note
49	RX7N	8 th Pixel Negative VbyOne differential data input in area A. Lan 7	(1)
50	RX7P	8 th Pixel Positive VbyOne differential data input in area A. Lan 7	
51	GND	Ground	

Connector Information

Item	Description
Manufacturer	FCN/ P-TWO
Type part number	FCN: WF23-402-5133 P-TWO: 187059-51221
User's Mating housing part number	JAE: FI-RE51HL

*Notice: There would be compatible issues if not using the indicated connectors in the matching list.

Note (1) V-by-One[®] HS Data Mapping

Lan	Data Stream
Lan 0	1, 9, 17,, 3825, 3833
Lan 1	2, 10, 18,, 3826, 3834
Lan 2	3, 11, 19,, 3827, 3835
Lan 3	4, 12, 20,, 3828, 3836
Lan 4	5, 13, 21,, 3829, 3837
Lan 5	6, 14, 22,, 3830, 3838
Lan 6	7, 15, 23,, 3831, 3839
Lan 7	8, 16, 24,, 3832, 3840

Note (2) Reserved for internal use. Please leave it open.

Note (3) VbyOne HS connector pin order defined as following:

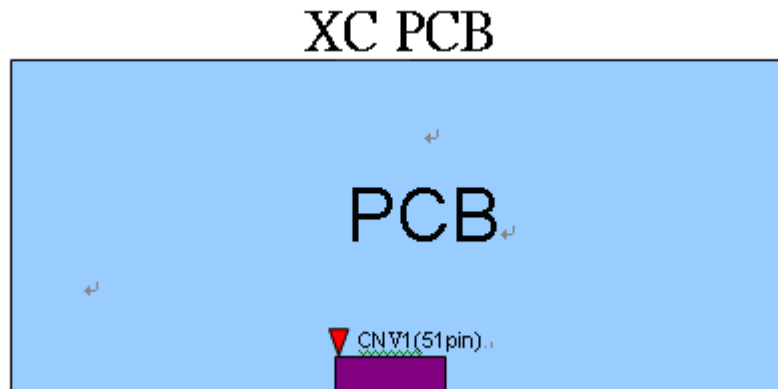

Note (4) V-by-One connector mating dimension range request is 0.93mm~1.0mm as below:

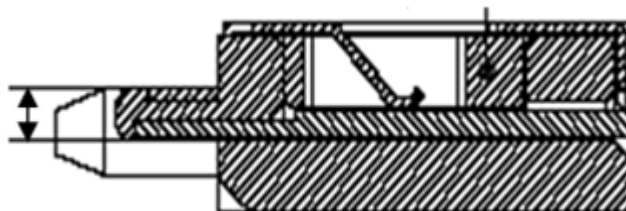

Note (5) The first pixel is odd.

Note (6) Input signal of even and odd clock should be the same timing

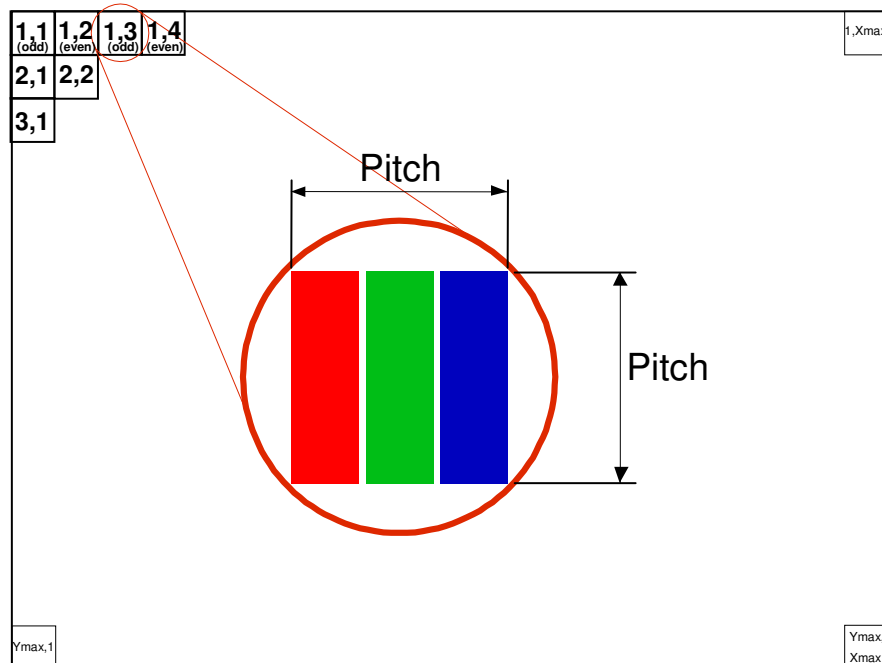

4.3 ELECTRICAL CHARACTERISTICS

4.3.1 LCD ELETRONICS SPECIFICATION

(Ta = 25 ± 2 °C)

Parameter	Symbol	Value			Unit	Note	
		Min.	Typ.	Max.			
Power Supply Voltage	V _{CC}	10.8	12	13.2	V	(1)	
Rush Current	I _{RUSH}	—	—	2.6	A	(2)	
Power Consumption	White Pattern	P _T	—	7.44	8.07	W	(3)
	Black Pattern	P _T	—	7.39	8.00	W	
	Horizontal Stripe	P _T	—	14.11	15.29	W	
Power Supply Current	White Pattern	—	—	0.62	0.75	A	(3)
	Black Pattern	—	—	0.62	0.75	A	
	Horizontal Stripe	—	—	1.18	1.42	A	
VbyOne HS	Differential Input High Threshold Voltage	VLVTH	—	—	+50	mV	
	Differential Input Low Threshold Voltage	VLVTL	-50	—	—	mV	
	Differential Input Resistor	RRIN	80	100	120	ohm	
CMOS interface	Input High Threshold Voltage	VIH	2.7	—	3.3	V	
	Input Low Threshold Voltage	VIL	0	—	0.7	V	

Note (1) The module should be always operated within the above ranges. The ripple voltage should be controlled under 10 % of Vcc (Typ.)

Note (2) Measurement Conditions

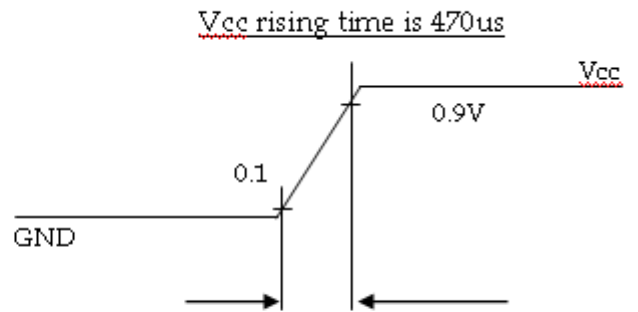
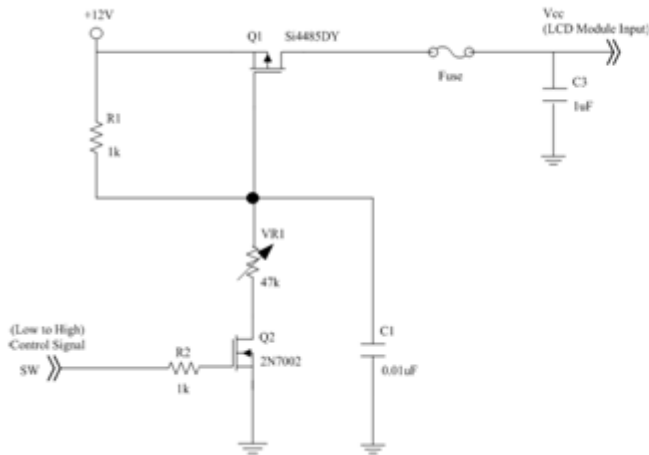

Note (3) The specified power supply current is under the conditions at Vcc = 12 V, Ta = 25 ± 2 °C, Fr = 60Hz, whereas a power dissipation check pattern below is displayed.

a. White Pattern

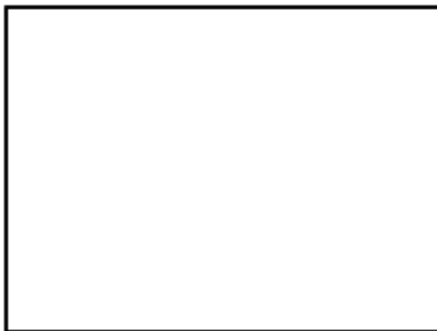

Active Area

b. Black Pattern

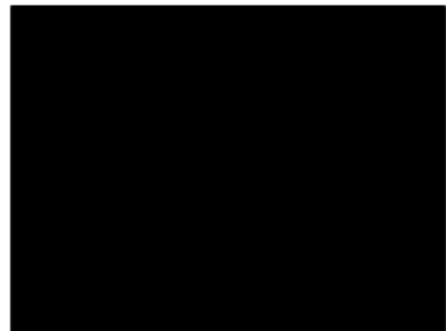

Active Area

c. Horizontal Pattern

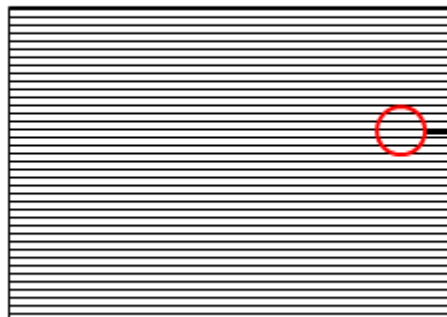

4.3.2.BACKLIGHT UNIT

Parameter	Symbol	Value			Unit	Note
		Min.	Typ.	Max.		
LED Light Bar Input Voltage Per Input Pin	VPIN	-	(60.16)	(64.28)	V	(1), Duty=100%, IPIN=110mA
LED Light Bar Current Per Input Pin	IPIN	(103.4)	110	(116.6)	mA	(1), (2) Duty=100%
LED Life Time	LLED	30000			Hrs	(3)
Power Consumption	PBL	-	(26.47)	(28.28)	W	(1) Duty=100%, IPIN=110mA

Note (1) LED light bar input voltage and current are measured by utilizing a true RMS multimeter as shown below:

Note (2) $PBL = IPIN \times VPIN \times (4)$ input pins.

Note (3) The lifetime of LED is defined as the time when LED packages continue to operate under the conditions at $Ta = 25 \pm 2 \text{ }^\circ\text{C}$ and $I = (150)\text{mA}$ (per chip) until the brightness becomes $\leq 50\%$ of its original value.

Note (4) The module must be operated with constant driving current.

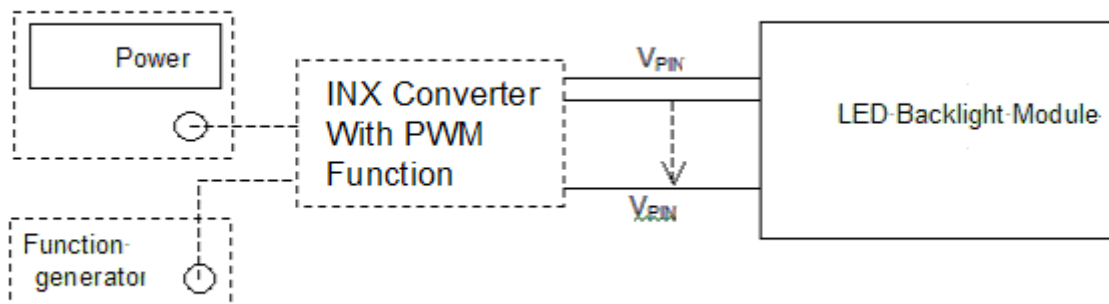

4.3.3 LIGHTBAR CONNECTOR PIN ASSIGNMENT:

(1) Connector Information:

Item	Description
Manufacturer	FCN
Type part number	WM13-406-083N(FCN)
Mating housing part number	WF1300108-B (FCN)

*Notice: There would be compatible issues if not using the indicated connectors in the matching list.

(2) LB Connector drawing:

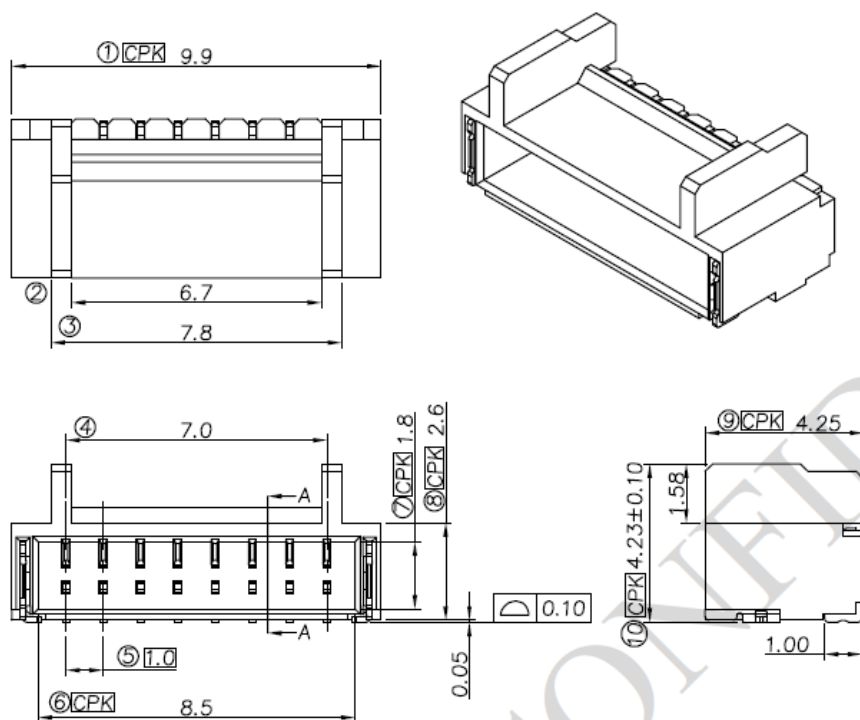

Pin number	Description
1	Cathode of LED string1
2	Cathode of LED string2
3	NC
4	VLED
5	VLED
6	NC
7	Cathode of LED string3
8	Cathode of LED string4

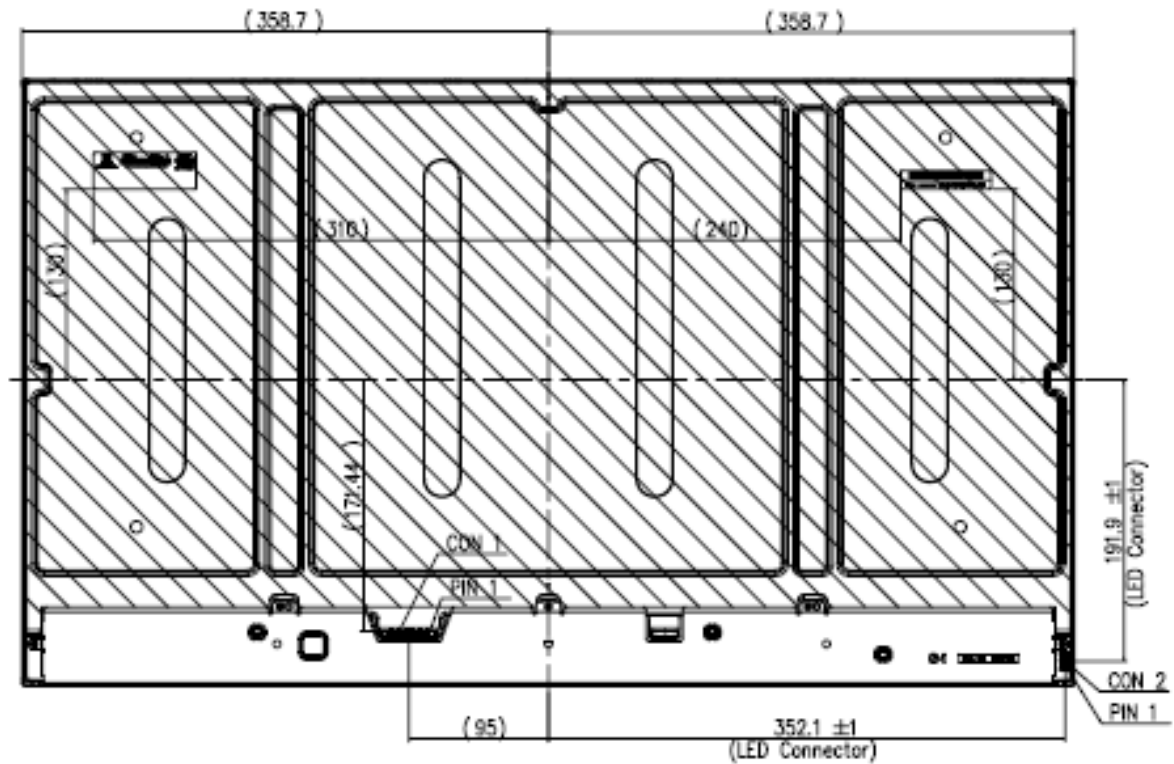

4.4 V BY ONE INPUT SIGNAL SPECIFICATIONS

4.4.1 V BY ONE DATA MAPPING TABLE

Lan	Data Stream
Lan 0	1, 9, 17,, 3825, 3833
Lan 1	2, 10, 18,, 3826, 3834
Lan 2	3, 11, 19,, 3827, 3835
Lan 3	4, 12, 20,, 3828, 3836
Lan 4	5, 13, 21,, 3829, 3837
Lan 5	6, 14, 22,, 3830, 3838
Lan 6	7, 15, 23,, 3831, 3839
Lan 7	8, 16, 24,, 3832, 3840

4.4.2 COLOR DATA INPUT ASSIGNMENT

The brightness of each primary color (red, green and blue) is based on the 10-bit gray scale data input for the color. The higher the binary input, the brighter the color. The table below provides the assignment of color versus data input.

Color		Data Signal																											
		Red										Green										BLUE							
		R9	R8	G7	G6	R5	R4	R3	R2	R1	R0	G9	G8	G7	G6	G5	G4	G3	G2	G1	G0	B9	B8	B7	B6	B5	B4	B3	B2
Basic Colors	Black	0	0	0	0	0	0	0	0	0	0	0	0	0	0	0	0	0	0	0	0	0	0	0	0	0	0	0	0
	Red	1	1	1	1	1	1	1	1	1	1	1	1	1	1	1	1	1	1	1	1	1	1	1	1	1	1	1	1
	Green	0	0	0	0	0	0	0	0	0	0	1	1	1	1	1	1	1	1	1	1	0	0	0	0	0	0	0	0
	Blue	0	0	0	0	0	0	0	0	0	0	0	0	0	0	0	0	0	0	0	1	1	1	1	1	1	1	1	1
	Cyan	0	0	0	0	0	0	0	0	0	1	1	1	1	1	1	1	1	1	1	1	1	1	1	1	1	1	1	1
	Magenta	1	1	1	1	1	1	1	1	1	1	0	0	0	0	0	0	0	0	0	0	1	1	1	1	1	1	1	1
	Yellow	1	1	1	1	1	1	1	1	1	1	1	1	1	1	1	1	1	1	1	0	0	0	0	0	0	0	0	0
	White	1	1	1	1	1	1	1	1	1	1	1	1	1	1	1	1	1	1	1	1	1	1	1	1	1	1	1	1
Gray Scale Of Red	Red(0) / Dark	0	0	0	0	0	0	0	0	0	0	0	0	0	0	0	0	0	0	0	0	0	0	0	0	0	0	0	
	Red(1)	0	0	0	0	0	0	0	0	1	0	0	0	0	0	0	0	0	0	0	0	0	0	0	0	0	0	0	
	Red(2)	0	0	0	0	0	0	0	1	0	0	0	0	0	0	0	0	0	0	0	0	0	0	0	0	0	0	0	
	⋮	⋮	⋮	⋮	⋮	⋮	⋮	⋮	⋮	⋮	⋮	⋮	⋮	⋮	⋮	⋮	⋮	⋮	⋮	⋮	⋮	⋮	⋮	⋮	⋮	⋮	⋮		
	Red(1021)	1	1	1	1	1	1	1	1	0	1	0	0	0	0	0	0	0	0	0	0	0	0	0	0	0	0	0	
	Red(1022)	1	1	1	1	1	1	1	1	1	0	0	0	0	0	0	0	0	0	0	0	0	0	0	0	0	0	0	
	Red(1023)	1	1	1	1	1	1	1	1	1	0	0	0	0	0	0	0	0	0	0	0	0	0	0	0	0	0	0	
	Gray Scale Of Green	Green(0) / Dark	0	0	0	0	0	0	0	0	0	0	0	0	0	0	0	0	0	0	0	0	0	0	0	0	0	0	0
Green(1)		0	0	0	0	0	0	0	0	0	0	0	0	0	0	0	0	0	1	0	0	0	0	0	0	0	0	0	
Green(2)		0	0	0	0	0	0	0	0	0	0	0	0	0	0	0	0	0	1	0	0	0	0	0	0	0	0	0	
⋮		⋮	⋮	⋮	⋮	⋮	⋮	⋮	⋮	⋮	⋮	⋮	⋮	⋮	⋮	⋮	⋮	⋮	⋮	⋮	⋮	⋮	⋮	⋮	⋮	⋮	⋮		
Green(1021)		0	0	0	0	0	0	0	0	0	1	1	1	1	1	1	1	1	1	0	1	0	0	0	0	0	0	0	
Green(1022)		0	0	0	0	0	0	0	0	0	1	1	1	1	1	1	1	1	1	0	0	0	0	0	0	0	0	0	
Green(1023)		0	0	0	0	0	0	0	0	0	1	1	1	1	1	1	1	1	1	0	0	0	0	0	0	0	0	0	
Gray Scale Of Blue		Blue(0) / Dark	0	0	0	0	0	0	0	0	0	0	0	0	0	0	0	0	0	0	0	0	0	0	0	0	0	0	0
	Blue(1)	0	0	0	0	0	0	0	0	0	0	0	0	0	0	0	0	0	0	0	0	0	0	0	0	0	0	1	
	Blue(2)	0	0	0	0	0	0	0	0	0	0	0	0	0	0	0	0	0	0	0	0	0	0	0	0	0	0	1	
	⋮	⋮	⋮	⋮	⋮	⋮	⋮	⋮	⋮	⋮	⋮	⋮	⋮	⋮	⋮	⋮	⋮	⋮	⋮	⋮	⋮	⋮	⋮	⋮	⋮	⋮	⋮		
	Blue(1021)	0	0	0	0	0	0	0	0	0	0	0	0	0	0	0	0	0	0	0	1	1	1	1	1	1	1	0	
	Blue(1022)	0	0	0	0	0	0	0	0	0	0	0	0	0	0	0	0	0	0	0	1	1	1	1	1	1	1	0	
	Blue(1023)	0	0	0	0	0	0	0	0	0	0	0	0	0	0	0	0	0	0	0	1	1	1	1	1	1	1	1	

Note (1) 0: Low Level Voltage, 1: High Level Voltage

4.5 DISPLAY TIMING SPECIFICATIONS

The input signal timing specifications are shown as the following table and timing diagram.

Signal	Item	Symbol	Min.	Typ.	Max.	Unit	Note
V by One	Frequency	Fc	70	74.25	80	MHz	(1)
	Intra-Pair skew		-0.3	-	0.3	UI	(2)
	Inter-Pair skew		-5	-	5	UI	(3)
	Spread spectrum modulation range	F _{clkin_mod}	F _{clkin} -0.5%	-	F _{clkin} +0.5%	MHz	(4)
	Spread spectrum modulation frequency	F _{SSM}	-	-	30	KHz	
Vertical Display Term	Frame Rate	Fr	57.5	60	62.5	Hz	(5)(6)
	Total	Tv	2200	2250	2790	Th	Tv=Tvd+Tvb
	Active Display	Tvd	2160	2160	2160	Th	-
	Blank	Tvb	40	90	630	Th	-
Horizontal Display Term	Total	Th	530	550	570	Tc	Th=Thd+Thb
	Active Display	Thd	480	480	480	Tc	-
	Blank	Thb	50	70	90	Tc	-

Note (1) Please make sure the range of pixel clock has follow the below equation:

$$F_{clkin(max)} \geq Fr \times Tv \times Th$$

$$Fr \times Tv \times Th \geq F_{clkin(min)}$$

INPUT SIGNAL TIMING DIAGRAM

INPUT SIGNAL TIMING DIAGRAM

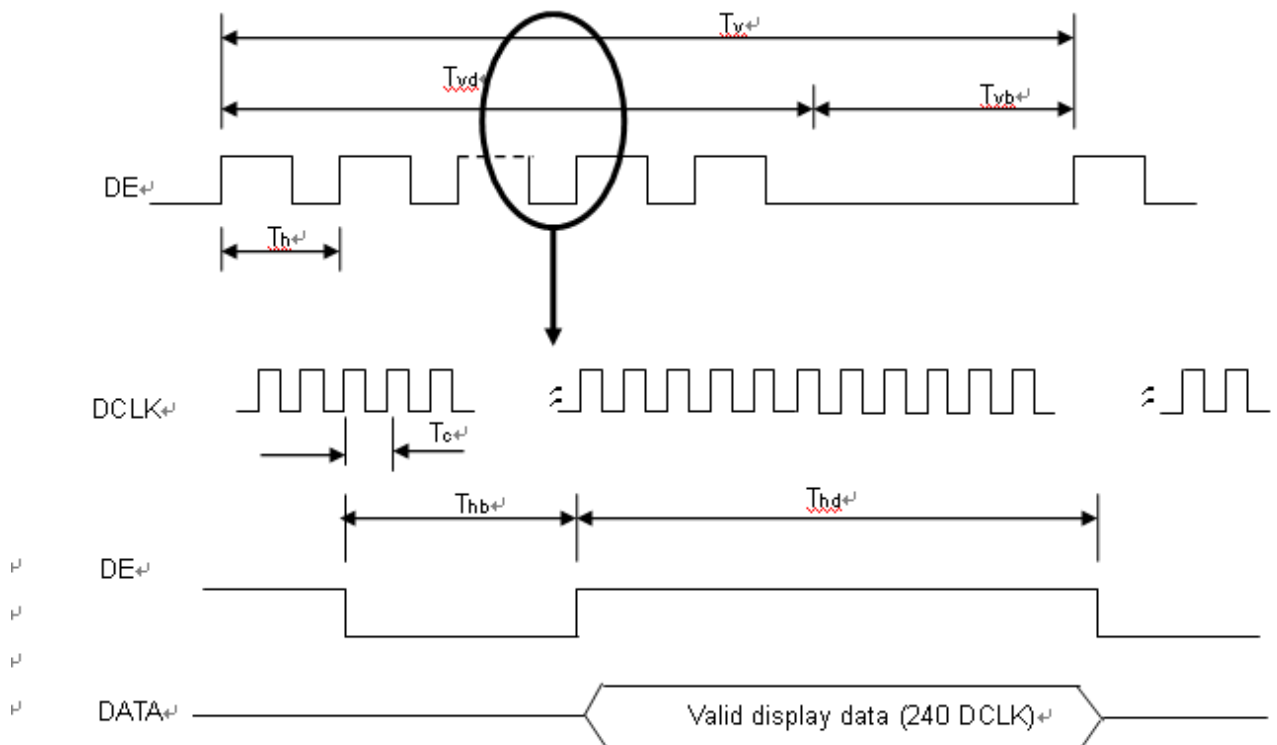

Note (2) V-by-One HS Intra-pair skew

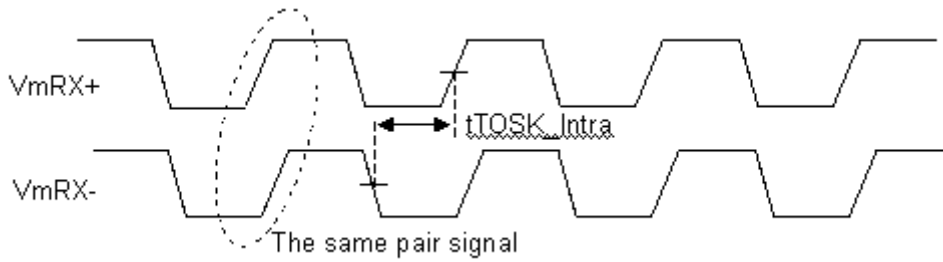

Note (3) V-by-One HS Inter-pair skew

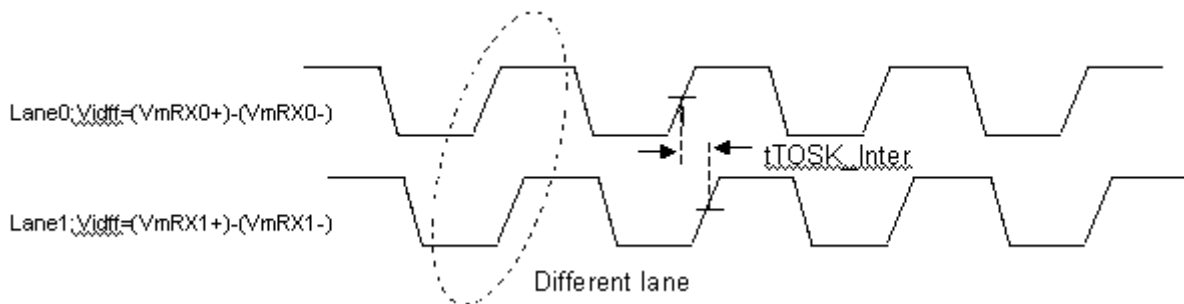

Note (4) The SSCG (Spread spectrum clock generator) is defined as below figures.

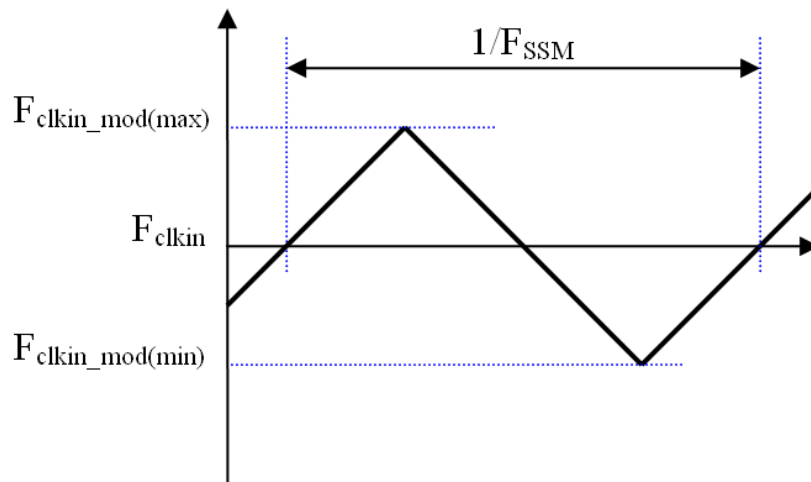

Note (5) The frame-to-frame jitter of the input frame rate is defined as the above figures. $FR_n = FR_{n-1} \pm 0.5\%$.

Note (6) The setup of the frame rate jitter > 0.5% may result in the cosmetic LED backlight symptom and the electric function is affected.

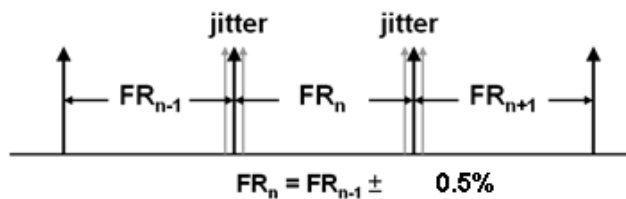

4.6 V BY ONE INPUT SIGNAL TIMING DIAGRAM

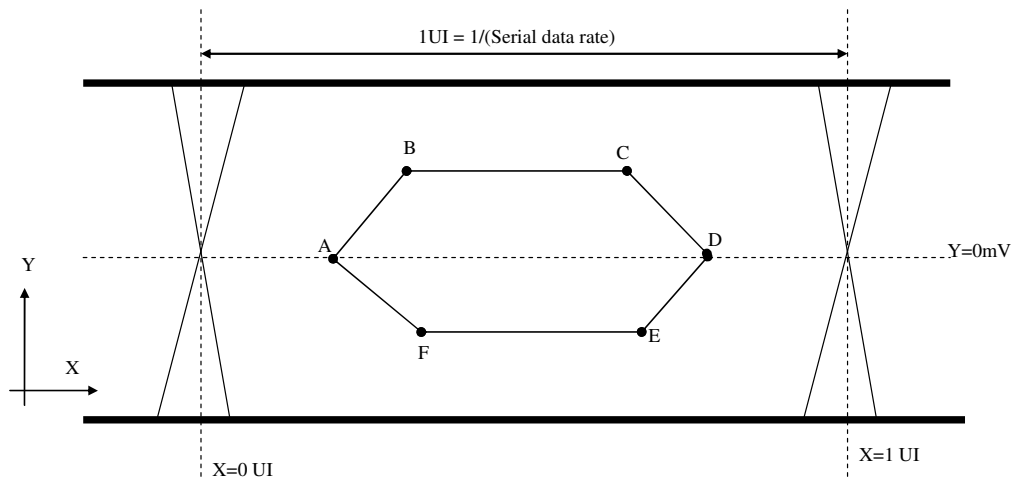

Table 1 Eye Mask Specification

	X [UI]	Y [mV]	Note
A	0.25	0	(1)
B	0.3	50	(1)
C	0.7	50	(1)
D	0.75	0	(1)
E	0.7	-50	(1)
F	0.3	-50	(1)

Note (1) Input levels of V-by-One HS signals are comes from “V-by-One HS Stander Ver.1.4”

4.7 BYTE LENGTH AND COLOR MAPPING OF V-BY-ONE HS

Packer input & Unpacker output		30bpp RGB (10bit)
Byte 0	D[0]	R[2]
	D[1]	R[3]
	D[2]	R[4]
	D[3]	R[5]
	D[4]	R[6]
	D[5]	R[7]
	D[6]	R[8]
	D[7]	R[9]
Byte 1	D[8]	G[2]
	D[9]	G[3]
	D[10]	G[4]
	D[11]	G[5]
	D[12]	G[6]
	D[13]	G[7]
	D[14]	G[8]
	D[15]	G[9]
Byte 2	D[16]	B[2]
	D[17]	B[3]
	D[18]	B[4]
	D[19]	B[5]
	D[20]	B[6]
	D[21]	B[7]
	D[22]	B[8]
	D[23]	B[9]
Byte 3	D[24]	X
	D[25]	X
	D[26]	B[0]
	D[27]	B[1]
	D[28]	G[0]
	D[29]	G[1]
	D[30]	R[0]
	D[31]	R[1]

4.8 POWER ON/OFF SEQUENCE

($T_a = 25 \pm 2 \text{ }^\circ\text{C}$)

To prevent a latch-up or DC operation of LCD module, the power on/off sequence should be as the diagram below.

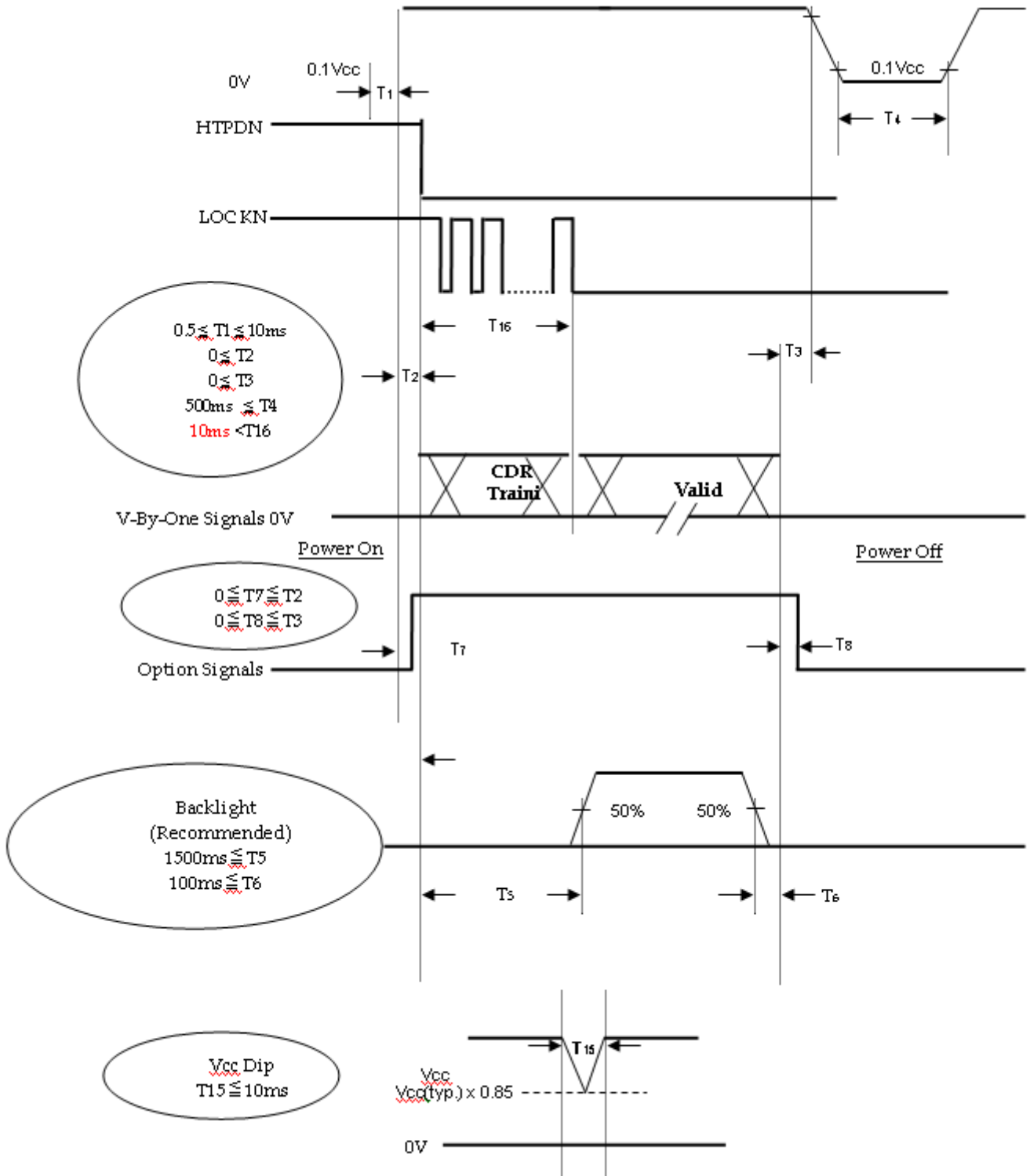

Note (1) The supply voltage of the external system for the module input should follow the definition of Vcc.

Note (2) Apply the LED voltage within the LCD operation range. When the backlight turns on before the LCD operation or the LCD turns off before the backlight turns off, the display may momentarily become abnormal screen..

Note (3) In case of Vcc is in off level, please keep the level of input signals on the low or high impedance. If $T_2 < 0$, that maybe cause electrical overstress failure.

Note (4) T4 should be measured after the module has been fully discharged between power off and on period..

Note (5) Interface signal shall not be kept at high impedance when the power is on

Note (6) Vcc must decay smoothly when power-off

5. OPTICAL CHARACTERISTICS

5.1 TEST CONDITIONS

Item	Symbol	Value	Unit
Ambient Temperature	Ta	25±2	oC
Ambient Humidity	Ha	50±10	%RH
Supply Voltage	VCC	12±0.12	V
Input Signal	According to typical value in "3. ELECTRICAL CHARACTERISTICS"		
LED Light Bar Input Current Per Input Pin	IPIN	110	mA
PWM Duty Ratio	D	100	%
LED Light Bar Test Converter	R373B00011100		

5.2 OPTICAL SPECIFICATIONS

The relative measurement methods of optical characteristics are shown in 5.2. The following items should be measured under the test conditions described in 5.1 and stable environment shown in Note (5).

Item	Symbol	Condition	Min.	Typ.	Max.	Unit	Note	
Color Chromaticity (CIE 1931)	Red	Rx	$\theta_x=0^\circ, \theta_y=0^\circ$ CS-2000 R=G=B=255 Gray scale	Typ - 0.03	(0.685)	Typ + 0.03	-	(1), (5)
		Ry			(0.310)			
	Green	Gx			(0.260)			
		Gy			(0.685)			
	Blue	Bx			(0.152)			
		By			(0.055)			
	White	Wx			0.313			
		Wy			0.329			
Center Luminance of White (Center of Screen)	Lc		250	300	-	cd/m ²	(4), (5)	
Contrast Ratio	CR		(2000)	(3000)	-	-	(2), (5)	
Response Time	Gray to Gray	$\theta_x=0^\circ, \theta_y=0^\circ$	-	(9.5)	(20)	ms	(3)	
White Variation	W	$\theta_x=0^\circ, \theta_y=0^\circ$	--	-	1.42	--	(5), (6)	
Viewing Angle	Horizontal	$\theta_{x-} + \theta_{x+}$	CR \geq 10	160	178	-	Deg.	(1), (5)
	Vertical	$\theta_{y-} + \theta_{y+}$		160	178	-		

Note (1) Definition of Viewing Angle (θ_x, θ_y):

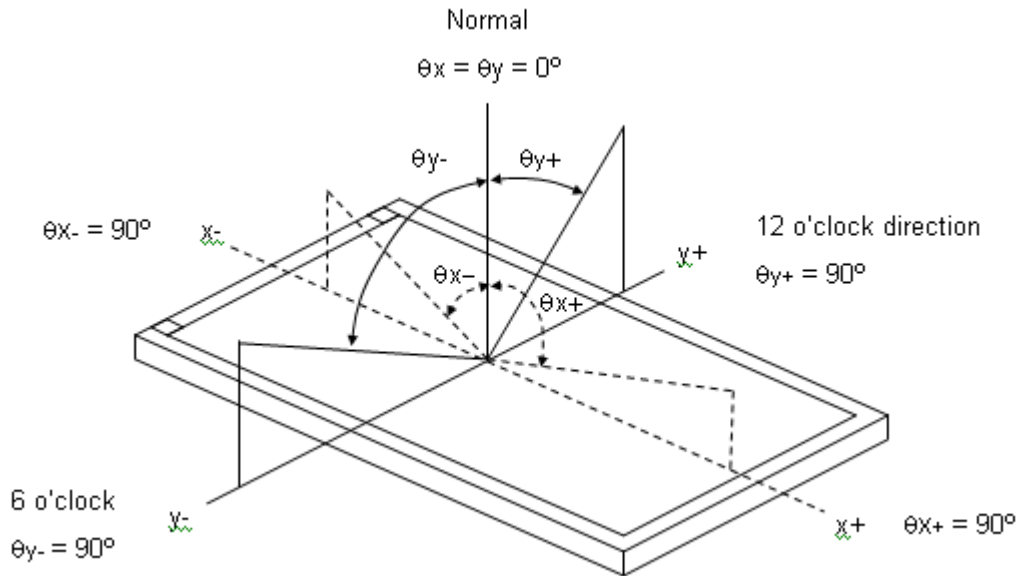

Note (2) Definition of Contrast Ratio (CR):

The contrast ratio can be calculated by the following expression.

$$\text{Contrast Ratio (CR)} = L_{255} / L_0$$

L255: Luminance of gray level 255

L 0: Luminance of gray level 0

$$\text{CR} = \text{CR} (5)$$

CR (X) is corresponding to the Contrast Ratio of the point X at Figure in Note (6).

Note (3) Definition of Gray-to-Gray Switching Time:

Optical Response

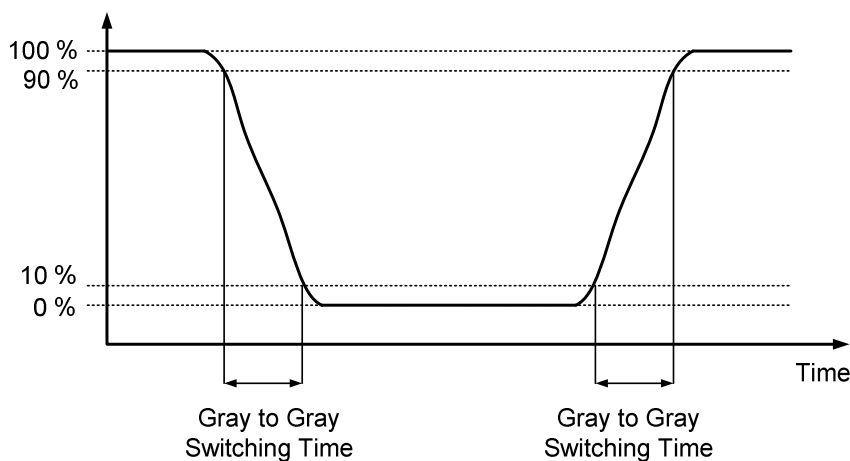

The driving signal means the signal of gray level 0, 31, 63, 95, 127, 159, 191, 223 and 255.

Gray to gray average time means the average switching time of gray level 0, 31, 63, 95, 127, 159, 191, 223 and 255 to each other

Note (4) Definition of Luminance of White (L_C):

Measure the luminance of gray level 255 at center point

$$L_C = L(5)$$

$L(x)$ is corresponding to the luminance of the point X at Figure in Note (6).

Note (5) Measurement Setup:

The LCD module should be stabilized at given temperature for 40 minutes to avoid abrupt temperature change during measuring. In order to stabilize the luminance, the measurement should be executed after lighting Backlight for 40 minutes in a windless room.

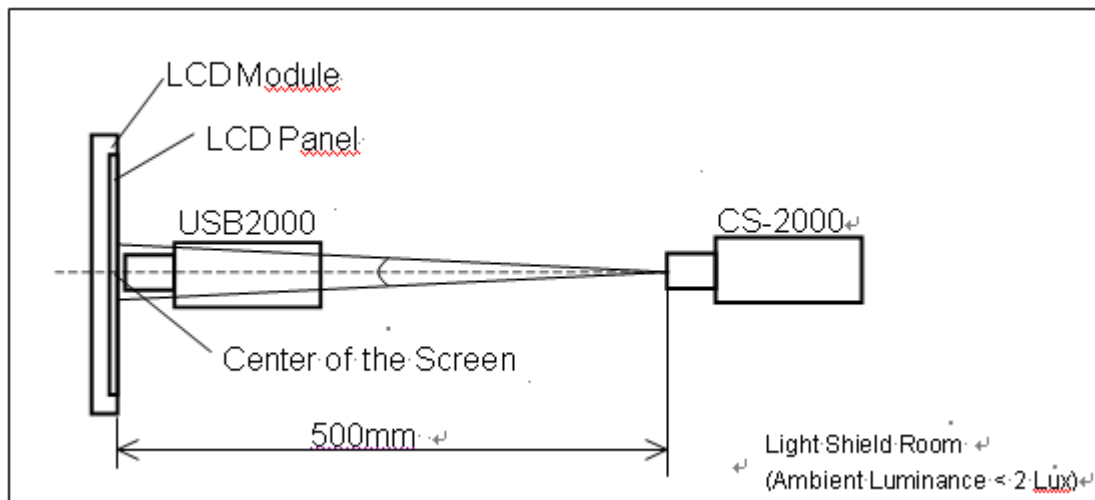

Note (6) Definition of White Variation (δW):

Measure the luminance of gray level 255 at 9 points

$$\delta W = \text{Maximum} [L(1) \sim L(9)] / \text{Minimum} [L(1) \sim L(9)]$$

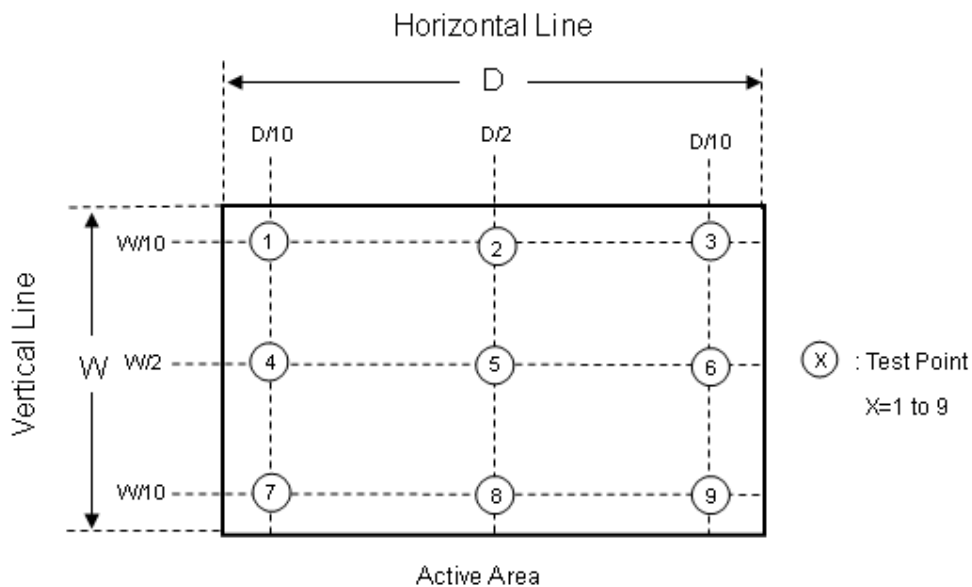

6. RELIABILITY TEST ITEM

Items	Required Condition	Note
Temperature Humidity Bias (THB)	Ta= 50°C , 80%RH, 240hours	
High Temperature Operation (HTO)	Ta= 50°C , 240hours	
Low Temperature Operation (LTO)	Ta= 0°C , 240hours	
High Temperature Storage (HTS)	Ta= 60°C , 240hours	
Low Temperature Storage (LTS)	Ta= -20°C , 240hours	
Vibration Test (Non-operation)	Acceleration: 1.5 G Wave: sine Frequency: 10 - 300 Hz Sweep: 30 Minutes each Axis (X, Y, Z)	
Shock Test (Non-operation)	Acceleration: 50 G Wave: Half-sine Active Time: 11 ms Direction : ± X, ± Y, ± Z.(one time for each Axis)	
Thermal Shock Test (TST)	-20°C/30min , 60°C / 30min , 100 cycles	
On/Off Test	25°C ,On/10sec , Off /10sec , 30,000 cycles	
ESD (Electro Static Discharge)	Contact Discharge: ± 8KV, 150pF(330Ω)	
	Air Discharge: ± 15KV, 150pF(330Ω)	
Altitude Test	Operation:10,000 ft / 24hours	
	Non-Operation:30,000 ft / 24hours	

Note (1) criteria : Normal display image with no obvious non-uniformity and no line defect.

Note (2) Evaluation should be tested after storage at room temperature for more than two hour

Note (3) At testing Vibration and Shock, the fixture in holding the module has to be hard and rigid enough so that the module would not be twisted or bent by the fixture.

The fixing condition is shown as below:

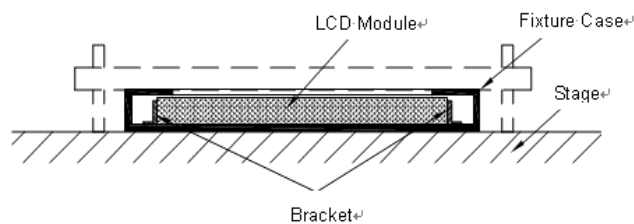

7. MECHANICAL STRENGTH CHARACTERISTICS

7.1 MECHANICAL STRENGTH SPECIFICATIONS

Item	Condition	Min	Unit	Note
Mechanical Strength	128 th Gray Pattern	0.6	Kgf	

7.2 TEST CONDITIONS

Items	Description
Test Condition	1. Ambient Illumination : 10~15 lux 2. Test Pattern : 128 Gray 3. Distance of the judgment : 30cm from the surface of module 4. Viewing angle of the judgment : Front
Gage Information	1. Push pull guage a. Model name : HF-50, maker : ALGOL b. Shape of gage tip - Diameter : 2mm - Thickness : 2mm
Definition of Minimum force	To measure minimum force when operator detects any white spot and light leakage that have occurred while operator presses on back side of module with push pull guage.

7.3 DEFINITION OF TEST POINTS

Measure the minimum force of test points at 128th Gray pattern. The test points at back side of module area is showing as below (If the test points on the PCBA, these points are not included)..

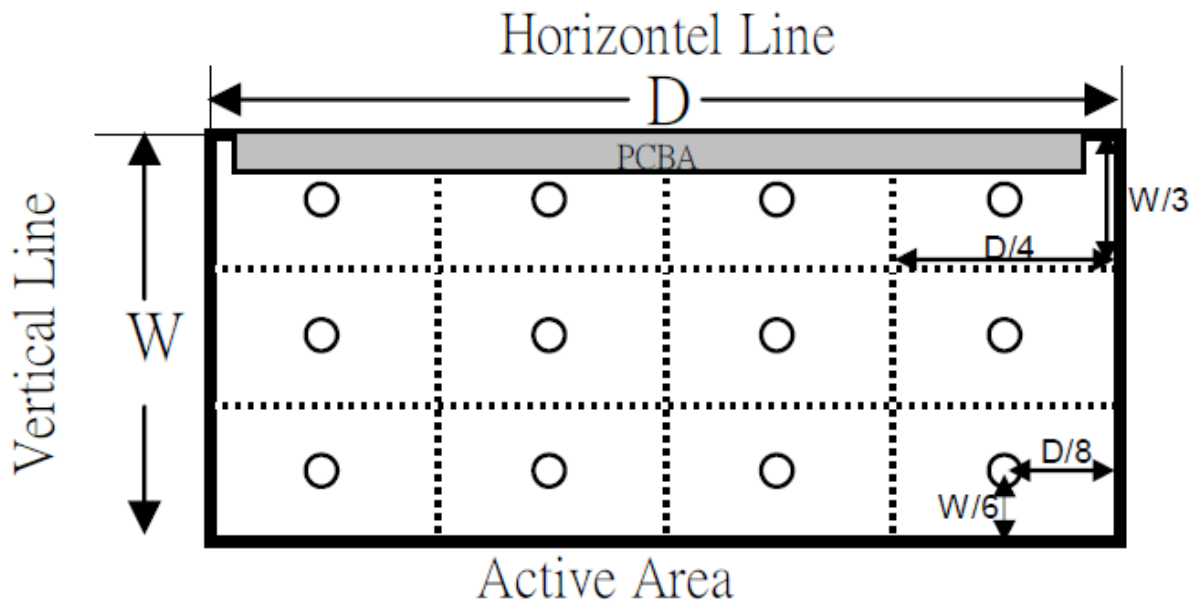

8. PACKING

8.1 PACKING SPECIFICATIONS

- (1) 8 LCD modules / 1 Box
- (2) Box dimensions: 826(L) X 376(W) X 540(H) mm
- (3) Weight: approximately: 35 Kg (8 modules per box)

8.2 PACKING METHOD

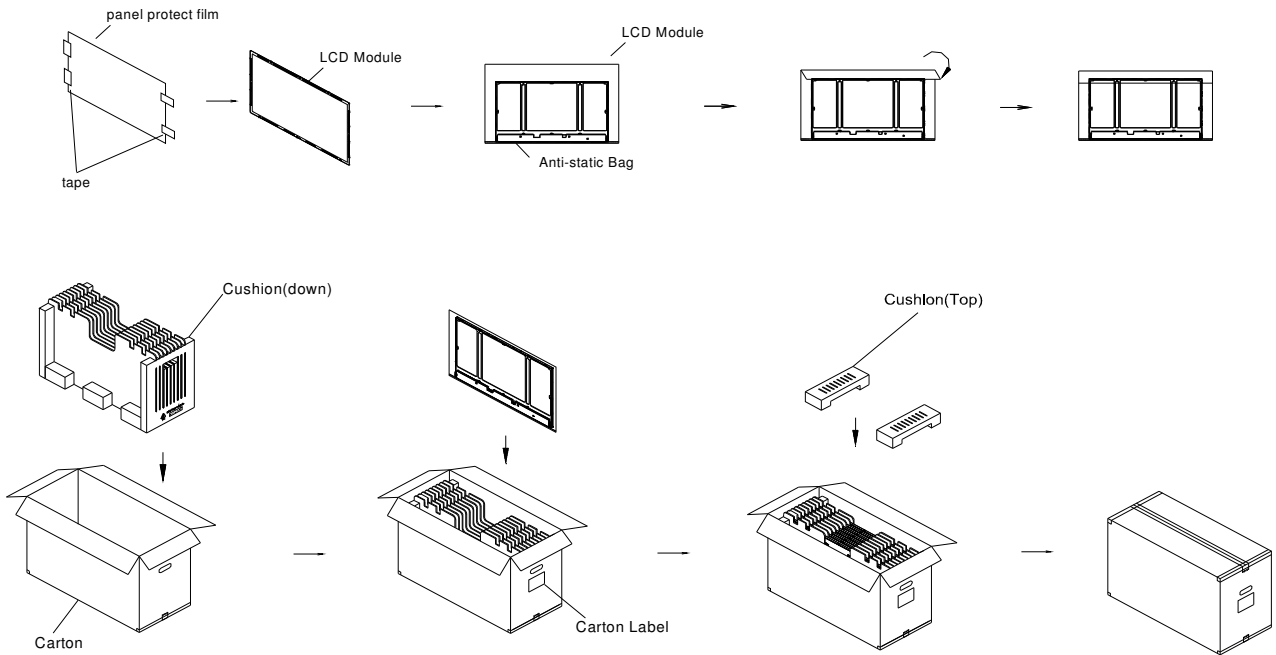

- (1) Carton dimensions: 826(L)x376(W)x540(H)mm
- (2) 8 modules / carton

Figure. 8-1 Packing method

8.3 PALLET

For ocean shipping

Air Transportation

2 Layer

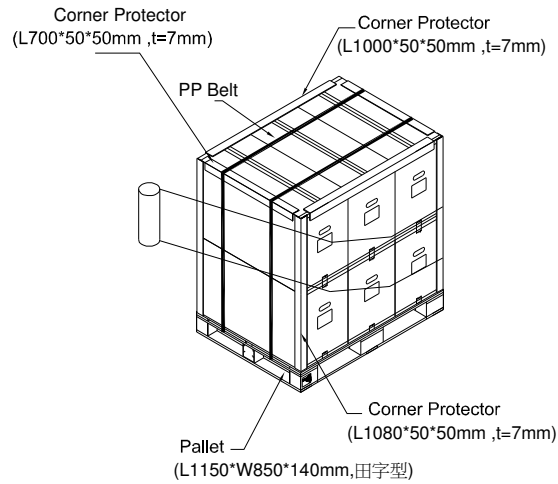

Sea / Land Transportation (40ft HQ Container)

3+2 Layer

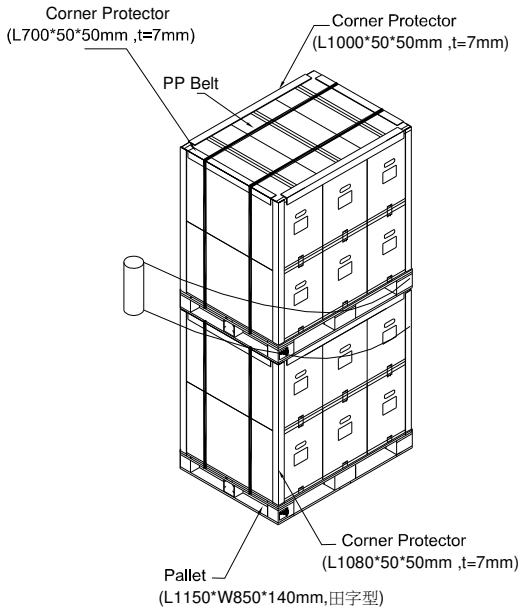

Sea / Land Transportation (40ft Container)

3 Layer

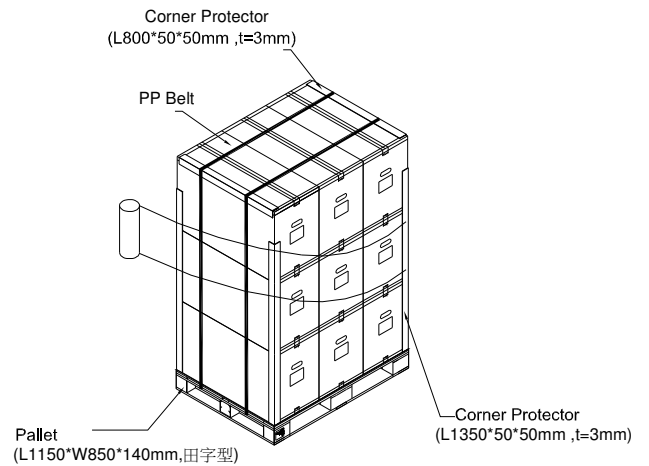

Figure. 8-2 Packing method

8.4 UN-PACKING METHOD

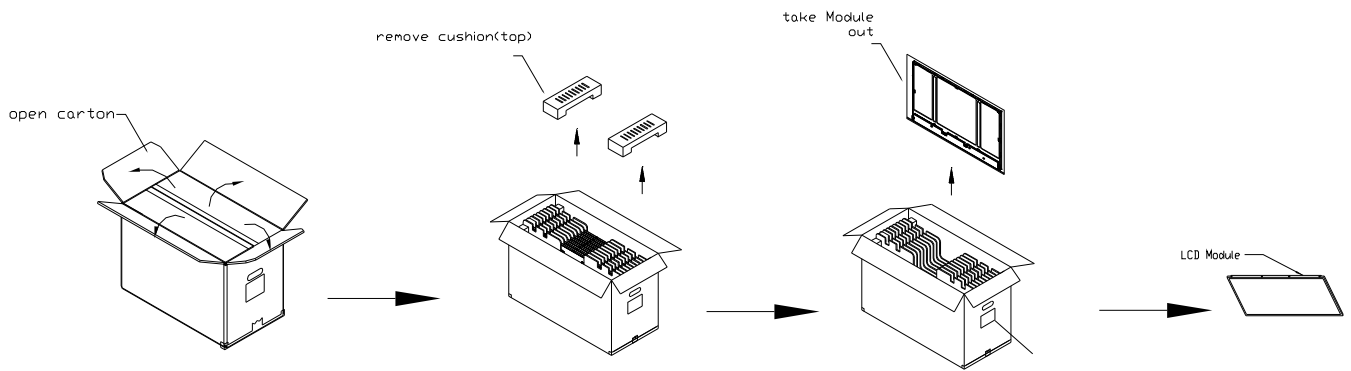

Figure. 8-3 UN-Packing method

9. INX MODULE LABEL

The barcode nameplate is pasted on each module as illustration, and its definitions are as following explanation.



(a) Model Name: M315DJJ-K30

(b) Revision: Rev. XX, for example: A0, A1... B1, B2... or C1, C2...etc.

(c) InnoLux barcode definition:

Serial ID: XX-XX-X-XX-YMD-L-NNNN

Code	Meaning	Description
XX	InnoLux internal use	-
XX	Revision	Cover all the change
X	InnoLux internal use	-
XX	InnoLux internal use	-
YMD	Year, month, day	Year: 0~9, 2001=1, 2002=2, 2003=3...2010=0, 2011=1, 2012=2... Month: 1~12=1, 2, 3, ~, 9, A, B, C Day: 1~31=1, 2, 3, ~, 9, A, B, C, ~, W, X, Y, exclude I, O, and U.
L	Product line #	Line 1=1, Line 2=2, Line 3=3, ...
NNNN	Serial number	Manufacturing sequence of product

(d) Customer's barcode definition:

Serial ID: CM-V5J03-X-X-X-XX-L-XX-L-YMD-NNNN

Code	Meaning	Description
CM	Supplier code	INX=CM
V5J30	Model number	M315DJJ-K30= V5J30
X	Revision code	Non ZBD: 1,2,~,8,9 / ZBD: A~Z
X	Source driver IC code	Century=1, CLL=2, Demos=3, Epson=4, Fujitsu=5, Himax=6, Hitachi=7, Hynix=8, LDI=9, Matsushita=A, NEC=B, Novatec=C, OKI=D, Philips=E, Renesas=F, Samsung=G, Sanyo=H, Sharp=I, TI=J, Topro=K, Toshiba=L, Windbond=M, ILITEK=Q, Fiti=Y, None IC =Z
X	Gate driver IC code	Century=1, CLL=2, Demos=3, Epson=4, Fujitsu=5, Himax=6, Hitachi=7, Hynix=8, LDI=9, Matsushita=A, NEC=B, Novatec=C, OKI=D, Philips=E, Renesas=F, Samsung=G, Sanyo=H, Sharp=I, TI=J, Topro=K, Toshiba=L, Windbond=M, ILITEK=Q, Fiti=Y, None IC =Z
XX	Cell location	Tainan Taiwan=TN, Ningbo China=CN, Hsinchu Taiwan=SC
L	Cell line #	1,2,~,9,A,B,~,Y,Z
XX	Module location	Tainan, Taiwan=TN, Ningbo China=NP, Shenzhen China=SH, Nanhai China=NH
L	Module line #	1,2,~,9,A,B,~,Y,Z
YMD	Year, month, day	Year: 0~9, 2001=1, 2002=2, 2003=3...2010=0, 2011=1, 2012=2... Month: 1~12=1, 2, 3, ~, 9, A, B, C Day: 1~31=1, 2, 3, ~, 9, A, B, C, ~, T, U, V
NNNN	Serial number	By LCD supplier

(e) FAB ID(UL Factory ID):

Region	Factory ID
TWINX	GEMN
NBCMI	LEOO
NBCMI	VIRO
NBCME	CANO
NHCMI	CAPG

10. PRECAUTIONS

10.1 ASSEMBLY AND HANDLING PRECAUTIONS

- (1) Do not apply rough force such as bending or twisting to the module during assembly.
- (2) To assemble or install module into user's system can be only in clean working areas. The dust and oil may cause electrical short or worsen the polarizer.
- (3) It's not permitted to have pressure or impulse on the module because the LCD panel and Backlight will be damaged.
- (4) Always follow the correct power sequence when LCD module is connecting and operating. This can prevent damage to the CMOS LSI chips during latch-up.
- (5) Do not pull the I/F connector in or out while the module is operating.
- (6) Do not disassemble the module.
- (7) Use a soft dry cloth without chemicals for cleaning, because the surface of polarizer is very soft and easily scratched.
- (8) It is dangerous that moisture come into or contacted the LCD module, because moisture may damage LCD module when it is operating.
- (9) High temperature or humidity may reduce the performance of module. Please store LCD module within the specified storage conditions.
- (10) When ambient temperature is lower than 10°C may reduce the display quality. For example, the response time will become slowly.
- (11) While touching the panel surface under the patterns with higher grey levels, a shadow or mura phenomenon would be seen. This phenomenon is totally recoverable by switching the patterns to lower grey levels. It is a product feature

10.2 STORAGE PRECAUTIONS

- (1) Do not leave the module in high temperature, and high humidity for a long time. It is highly recommended to store the module with temperature from 0°C to 35°C and relative humidity of less than 70%
- (2) Do not store the TFT – LCD module in direct sunlight
- (3) The module should be stored in dark place. It is prohibited to apply sunlight or fluorescent light in storing

10.3 OPERATION PRECAUTIONS

(1) The LCD product should be operated under normal condition.

Normal condition is defined as below :

Temperature : 20±15°C

Humidity: 65±20%

Display pattern : continually changing pattern(Not stationary)

(2) If the product will be used in extreme conditions such as high temperature,high humidity,high altitude ,display pattern or operation time etc...It is strongly recommended to contact INX for application engineering advice . Otherwise , Its reliability and function may not be guaranteed.

10.4 SAFETY PRECAUTIONS

(1) If the liquid crystal material leaks from the panel, it should be kept away from the eyes or mouth. In case of contact with hands, skin or clothes, it has to be washed away thoroughly with soap.

(2) After the module's end of life, it is not harmful in case of normal operation and storage.

10.5 SAFETY STANDARDS





The LCD module should be certified with safety regulations as follows:

Requirement	Standard	remark
UL	UL60950-1:2006 or Ed.2:2007	
cUL/CSA	CAN/CSA C22.2 No.60950-1-03 or 60950-1-07	
CB	IEC60950-1:2005 / EN60950-1:2006+ A11:2009	

10.6 OTHER

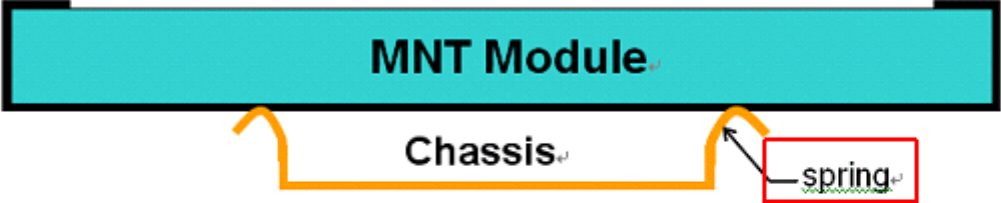
When fixed patterns are displayed for a long time, remnant image is likely to occur.

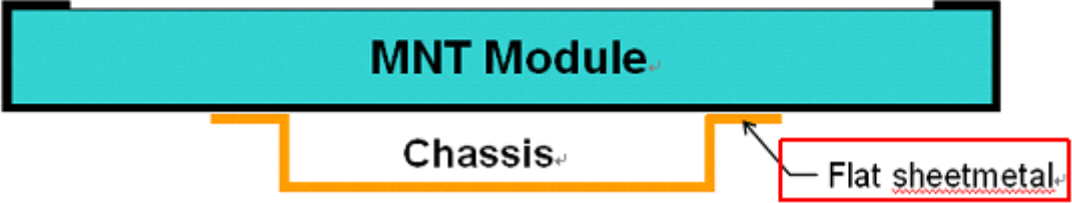
Appendix 1. SYSTEM COVER DESIGN NOTICE

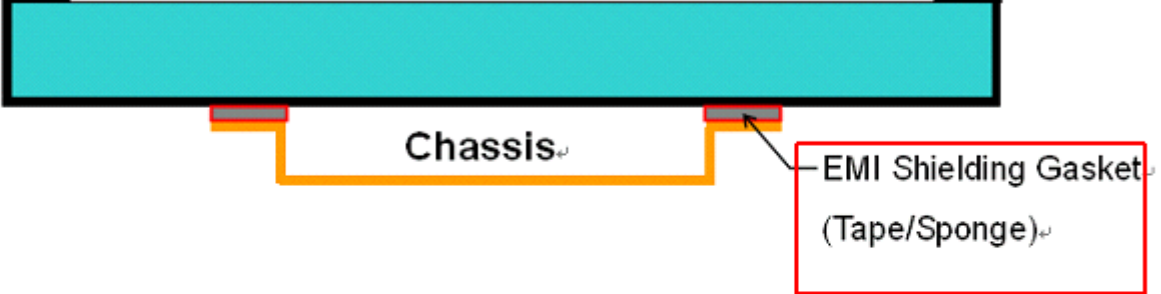
1.	Set Chassis and MNT Module touching Mode
	 <p>MNT Module</p> <p>Chassis</p> <p>spring</p>
	 <p>MNT Module</p> <p>Chassis</p> <p>Flat sheetmetal</p>
	 <p>MNT Module</p> <p>Chassis</p> <p>EMI Shielding Gasket (Tape/Sponge)</p>
<p>Definition</p>	<p>a) To prevent from abnormal display & white spot after Mechanical test, it is not recommended to used <u>spring</u> type chassis.</p> <p>b) We suggest the contact mode between Chassis and Module rear cover is Tape/Sponge, second is Flat <u>sheetmetal</u> type chassis (Don't interference from flat <u>sheetmetal</u> of chassis to rear cover of Module).</p>

2	Tape/sponge design on system inner surface
<p>The diagram illustrates the correct and incorrect placement of Tape/Sponge on the system inner surface. The top part shows a cross-section of the system with an MNT Module, Chassis, system front bezel, and System rear bezel. Red arrows point to the correct placement of Tape/Sponge between the chassis and the module rear cover. Below this, two diagrams illustrate incorrect placements: one with four separate L-shaped pieces of Tape/Sponge (marked with a red X) and one with a single rectangular piece of Tape/Sponge (marked with a blue circle).</p>	
Definition	<p>a) To prevent from abnormal display & white spot after Mechanical test, We suggest using Tape/Sponge as medium between chassis and Module rear cover could reduce the occurrence of white spot.</p> <p>b) When using the Tape/Sponge, suggest it be lay over between set chassis and module rear cover. it is not recommended to add tape/sponge in separate location. Since each tape/sponge may act as pressure concentration location.</p>

3	System inner surface examination
Definition	<p>a). Burr at logo edge, step, protrusion or PCB board will easily cause white spot.</p> <p>b). Keeping flat surface underneath module is recommended.</p> <p>c). The area () on Module PCBA and Light bar connector should keep at least 1mm gap to any structure with System cover inner surface.</p>

4	The overlapping part on System's Chassis and electric wire needs gap structure.
<p>The diagram illustrates the required gap structure for overlapping chassis and electric wire. On the left, two cross-sections are shown: 'A-A Section' shows an FFC electric wire overlapping a chassis, and 'B-B Section' shows an electric wire overlapping a chassis. On the right, a top-down view of the system chassis shows the LVDS connector, FPC, wire, and light bar connector. Red starburst symbols indicate the areas where a gap structure is needed to prevent interference.</p>	
Definition	The overlapping part on System's Chassis and electric wire (FPC、FFC and wire) needs gap structure to avoid display of white spot by pressing overlapping part cause interference.

5	System cover's ventilation outlet structure
<p>The diagram shows the ventilation outlet structure on the light source side of the module. A text label indicates: 'Set ventilation outlet structure on Light source side of module.' The diagram shows the light source edge (LED / Lamp) and the light source connector. A ventilation outlet structure is shown on the side of the module light bar in the system cover inner surface.</p>	
Definition	To prevent from abnormal display of light leakage, We suggest to set ventilation outlet structure on side of Module Light bar in system cover inner surface.

Appendix 2. OUTLINE DRAWING

REV	EC NUMBER	DESCRIPTION	DATE
△		First Release	2014/09/05
△	ER0093251	Modify BM WIDTH VARIATION	2015/03/05

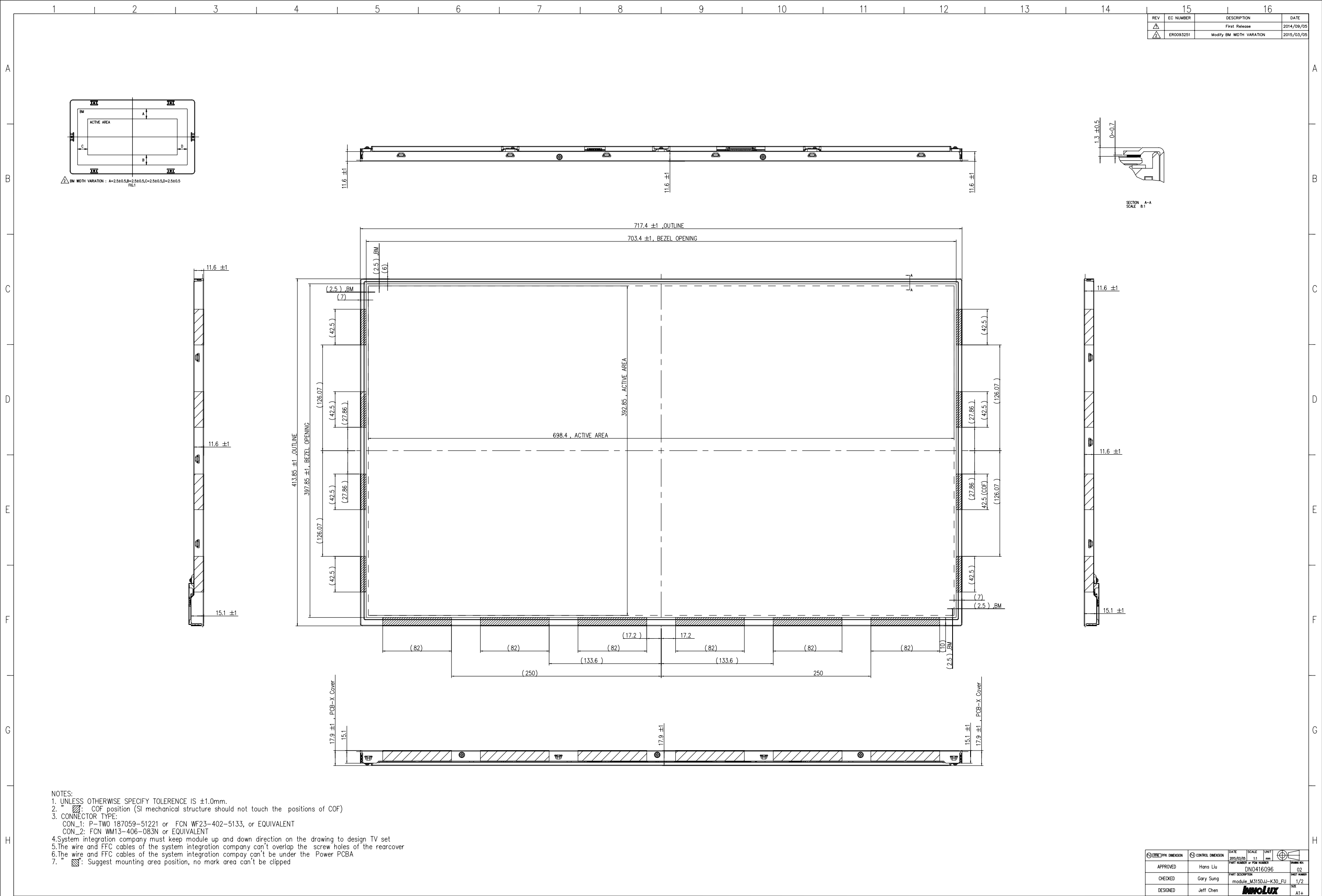
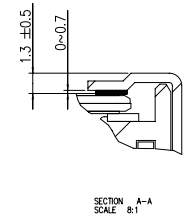
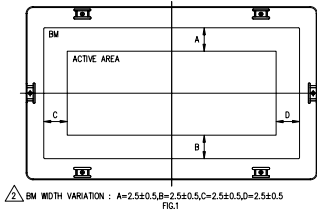

- NOTES:
- UNLESS OTHERWISE SPECIFY TOLERANCE IS ±1.0mm.
 - ☐: COF position (SI mechanical structure should not touch the positions of COF)
 - CONNECTOR TYPE:
 CON_1: P-TWO 187059-51221 or FCN WF23-402-5133, or EQUIVALENT
 CON_2: FCN WM13-406-083N or EQUIVALENT
 - System integration company must keep module up and down direction on the drawing to design TV set
 - The wire and FFC cables of the system integration company can't overlap the screw holes of the rearcover
 - The wire and FFC cables of the system integration company can't be under the Power PCBA
 - ☐: Suggest mounting area position, no mark area can't be clipped

APPROVED	CONTROL DIMENSION	DATE	SCALE	UNIT	FIGURE NO.
Hans Liu		2015/03/05	1:1	mm	02
Gary Sung					1/2
Jeff Chen					A1+



REV	EC NUMBER	DESCRIPTION	DATE
△		First Release	2014/09/05
△	ER0093251	Modify BM WIDTH VARIATION	2015/03/05

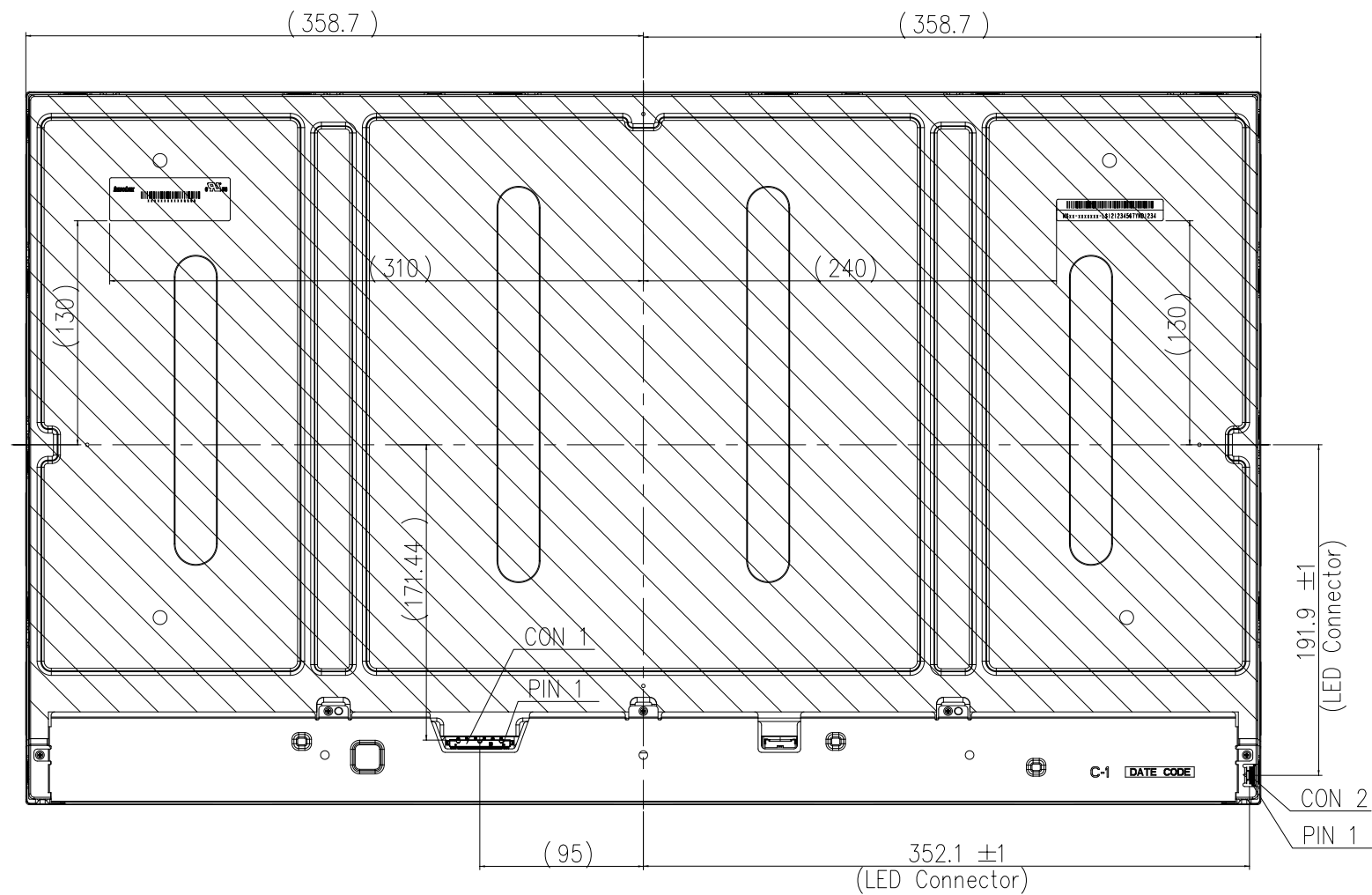

NOTES:

- UNLESS OTHERWISE SPECIFY TOLERANCE IS $\pm 1.0\text{mm}$.
- "": COF position (SI mechanical structure should not touch the positions of COF)
- CONNECTOR TYPE:
 CON_1: P-TWO 187059-51221 or FCN WF23-402-5133, or EQUIVALENT
 CON_2: FCN WM13-406-083N or EQUIVALENT
- System integration company must keep module up and down direction on the drawing to design TV set
- The wire and FFC cables of the system integration company can't overlap the screw holes of the rearcover
- The wire and FFC cables of the system integration company can't be under the Power PCBA
- "": Suggest mounting area position, no mark area can't be clipped

APPROVED	DESIGNED	CHECKED	DATE	SCALE	UNIT	FIGURE NO.	SHEET NUMBER
Hans Liu	Jeff Chen	Gary Sung	2015/03/05	1:1	mm	DN0416096	02
PART DESCRIPTION			PART NUMBER or P/N NUMBER		SHEET NUMBER		
module_M3150JU-K30_FU			M3150JU-K30_FU		2/2		
DRAWN BY			DATE		SCALE		
Jeff Chen			2015/03/05		1:1		
DRAWN BY			DATE		SCALE		
Jeff Chen			2015/03/05		1:1		

