

# MITSUBISHI MICROCOMPUTERS

# M37410E6HXXXFP

# M37410E6HFS

**PROM VERSION of M37410M3HXXXFP, M37410M4HXXXFP, M37410M6HXXXFP**

## DESCRIPTION

The M37410E6HFS, M37410E6HXXXFP are single-chip microcomputers designed with CMOS silicon gate technology. M37410E6HXXXFP is housed in a 80-pin shrink plastic molded QFP. M37410E6HFS is housed in a 80-pin ceramic QFP. The features of M37410E6HXXXFP are similar to those of the M37410M4HXXXFP except that this chip has a 12288 bytes PROM built in. This single-chip microcomputer is useful for home electrical appliances and consumer appliance controllers.

In addition to its simple instruction sets, the PROM, RAM, and I/O addresses are placed on the same memory map to enable easy programming. Since general purpose PROM writers can be used for the built-in PROM, this chip is suitable for small quantity production runs.

The M37410E6HFS are the window type. The differences between the M37410E6HXXXFP and the M37410E6HFS are the package outline and the power dissipation ability (absolute maximum ratings).

## FEATURES

- Number of basic instructions ..... 69
- Memory size PROM ..... 12288 bytes  
RAM ..... 256 bytes
- Instruction execution time (minimum instructions)  
at high-speed mode ..... 1 $\mu$ s  
at low-speed mode ..... 4 $\mu$ s
- Single power supply  
M37410E6HXXXFP ..... 2.5~5.5V  
M37410E6HFS ..... 4.5~5.5V
- Power dissipation  
normal operation mode (at 8MHz frequency)  
..... 30mW ( $V_{CC}=5V$ , Typ.)  
low-speed operation mode (at 32kHz frequency for  
clock function) ..... 54 $\mu$ W ( $V_{CC}=3V$ , Typ.)
- RAM retention voltage (stop mode)  
..... 2.0V  $\leq V_{RAM} \leq 5.5V$
- Subroutine nesting ..... 96 levels (Max.)
- Interrupt ..... 10 types, 5 vectors
- 8-bit timer ..... 4
- 16-bit timer ..... 1 (Two 8-bit timers make one set)
- Programmable I/O ports  
(Ports P0, P1, P2, P3, P5) ..... 40
- Input port (Port P4) ..... 4
- Serial I/O (8-bit) ..... 1
- A-D converter ..... 8-bit, 8-channel
- LCD controller/driver (1/2, 1/3 bias, 1/2, 1/3, 1/4 duty)  
segment output ..... 24  
common output ..... 4
- Two clock generating circuits  
(One is for main clock, the other is for clock function)
- PROM (equivalent to the M5L27128)  
program voltage ..... 21V

## PIN CONFIGURATION (TOP VIEW)

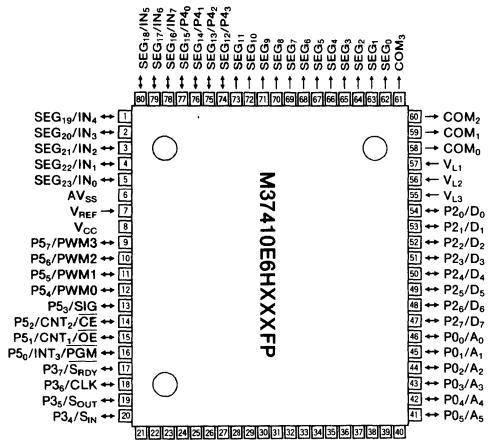

Outline 80P6S (OTP)

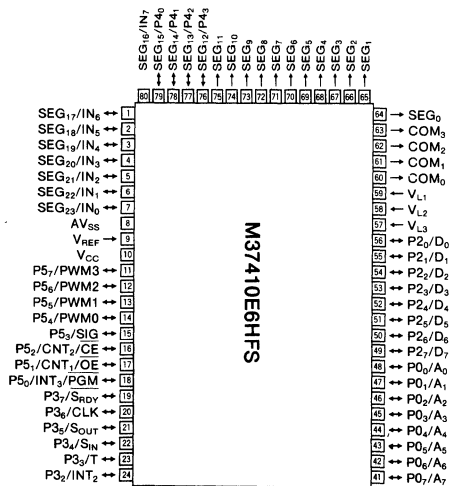

Outline 80S6 (Window)

## APPLICATION

- Audio-visual equipment
- Remote control
- Camera



# M37410E6HXXXFP BLOCK DIAGRAM

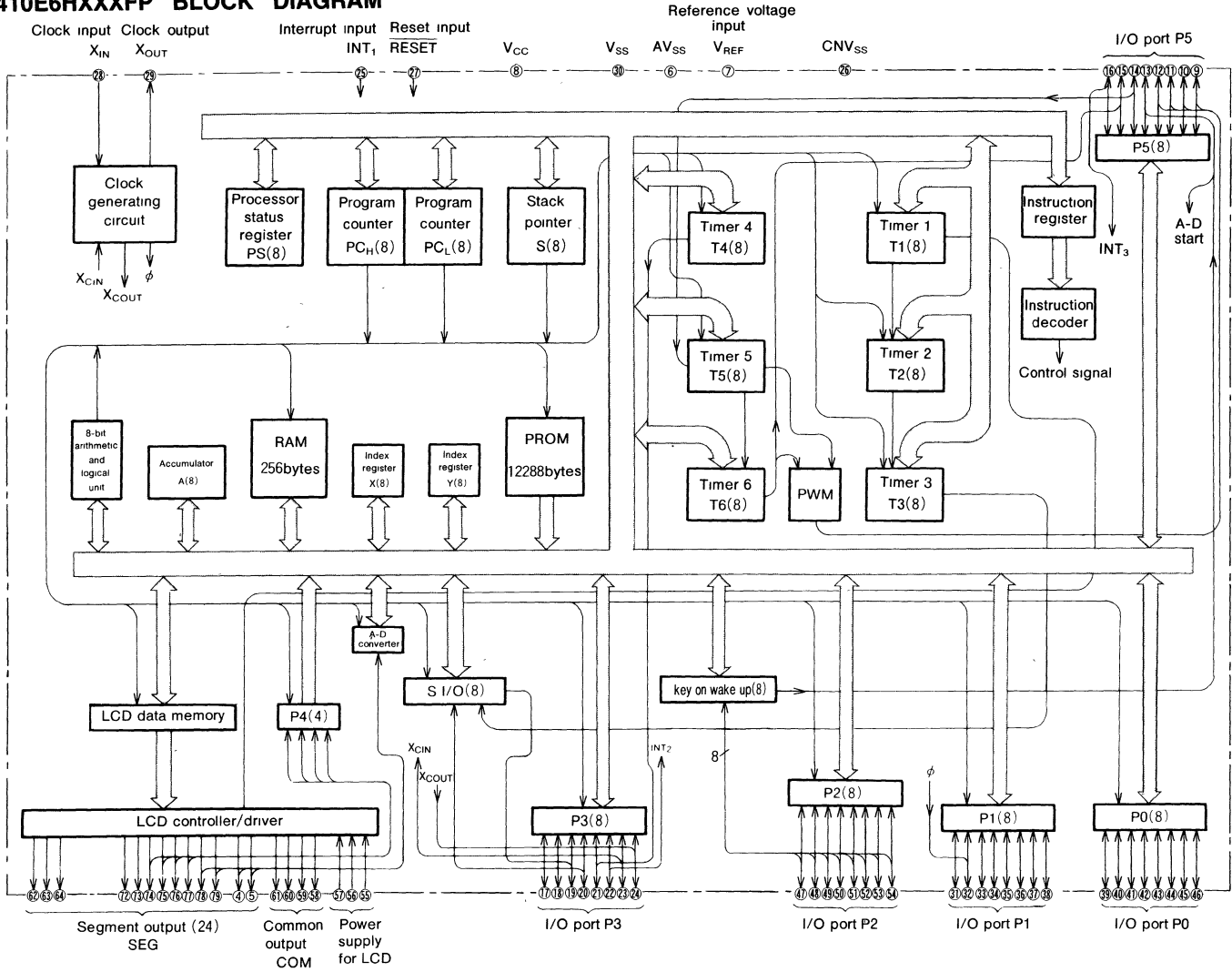

FROM VERSION OF M37410M3HXXXFP, M37410M4HXXXFP, M37410M6HXXXFP

MITSUBISHI MICROCOMPUTERS  
**M37410E6HXXXFP**  
**M37410E6HFS**

**M37410E6HXXFP**  
**M37410E6HFS**

**PROM VERSION of M37410M3HXXFP, M37410M4HXXFP, M37410M6HXXFP**

**FUNCTIONS OF M37410E6HXXFP**

Parameters		Functions
Number of basic instructions		69
Instruction execution time		1 $\mu$ s (minimum instructions, at 8MHz of frequency)
Clock frequency		8MHz
Memory size	PROM	12288bytes (Note 1)
	RAM	256bytes
	RAM for display LCD	12bytes
Input/Output port	P0, P1, P2, P3, P5	I/O 8-bitX5
	P4	Input 4-bitX1 (Port P4 are in common with SEG)
	SEG	LCD output 24-bitX1
	COM	LCD output 4-bitX1
Serial I/O		8-bitX1
Timers		8-bit timerX4 16-bit timerX1 (combination of two 8-bit timers)
LCD controller/driver	Bias	1/2, 1/3 bias selectable
	Duty ratio	1/2, 1/3, 1/4 duty selectable
	Common output	4
	Segment output	24(SEG <sub>12</sub> ~SEG <sub>23</sub> are in common with port P4 and analog input pins)
Subroutine nesting		96(max)
Interrupt		Three external interrupts, three timer interrupts (or two timer, one serial I/O)
Clock generating circuit		Two built-in circuits (ceramic or quartz crystal oscillator)
Operating temperature range		-10~70°C
Device structure		CMOS silicon gate
Package		80-pin plastic molded QFP

Note 1 : The PROM programming voltage is 21V (equivalent to the M5L27128)

**PROM VERSION of M37410M3HXXXFP, M37410M4HXXXFP, M37410M6HXXXFP**

**PIN DESCRIPTION**

Pin	Mode	Name	Input/ Output	Functions
V <sub>CC</sub> , V <sub>SS</sub>	Single-chip /EPROM	Power supply		Supply 5V±5% to V <sub>CC</sub> and 0V to V <sub>SS</sub>
CNV <sub>SS</sub> / V <sub>PP</sub>	Single-chip	CNV <sub>SS</sub>		Connect to V <sub>SS</sub> .
	EPROM	V <sub>PP</sub> input	Input	Connect to V <sub>PP</sub> when programming or verifying
RESET	Single-chip	Reset input	Input	To reset, keep this input terminal low for more than 16μs (min) under normal V <sub>CC</sub> conditions. If more time is needed for the crystal oscillator to stabilize, this "L" condition should be maintained for the required time.
	EPROM	Reset input		Connect to 0V.
X <sub>IN</sub>	Single-chip /EPROM	Clock input	Input	These are I/O pins of internal clock generating circuit for main clock. To control generating frequency, an external ceramic or a quartz crystal oscillator is connected between the X <sub>IN</sub> and X <sub>OUT</sub> pins. If an external clock is used, the clock source should be connected to the X <sub>IN</sub> pin and the X <sub>OUT</sub> pin should be left open.
X <sub>OUT</sub>		Clock output	Output	
INT <sub>1</sub>	Single-chip	Interrupt input	Input	This is the highest order interrupt input pin.
	EPROM	Interrupt input	Input	Connect to 0V.
P0 <sub>0</sub> ~P0 <sub>7</sub>	Single-chip	I/O port P0	I/O	Port P0 is an 8-bit I/O port with directional registers allowing each I/O bit to be individually programmed as input or output. At reset, this port is set to input mode. The output structure is CMOS output.
	EPROM	Address input A <sub>0</sub> ~A <sub>7</sub>	Input	P0 works as the lower 8 bit address input (A <sub>0</sub> ~A <sub>7</sub> ).
P1 <sub>0</sub> ~P1 <sub>7</sub>	Single-chip	I/O port P1	I/O	Port P1 is an 8-bit I/O port and has basically the same functions as port P0. The output structure is N-channel open drain.
	EPROM	Address input A <sub>8</sub> ~A <sub>13</sub>	Input	P1 <sub>0</sub> ~P1 <sub>5</sub> works as the higher 6 bit address inputs (A <sub>8</sub> ~A <sub>13</sub> ). Connect P1 <sub>6</sub> ~P1 <sub>7</sub> to V <sub>CC</sub> .
P2 <sub>0</sub> ~P2 <sub>7</sub>	Single-chip	I/O port P2	I/O	Port P2 is an 8-bit I/O port and has basically the same function as port P0. Also all bits are for key on wake up input pins.
	EPROM	Data input/ output D <sub>0</sub> ~D <sub>7</sub>	I/O	Port P2 works as an 8 bit data bus (D <sub>0</sub> ~D <sub>7</sub> ).
P3 <sub>0</sub> ~P3 <sub>7</sub>	Single-chip	I/O port P3	I/O	Port P3 is an 8-bit I/O port and has basically the same functions as port P0. When serial I/O is used, P3 <sub>7</sub> , P3 <sub>6</sub> , P3 <sub>5</sub> and P3 <sub>4</sub> work as S <sub>RDY</sub> , CLK, S <sub>OUT</sub> , and S <sub>IN</sub> pins, respectively. Also P3 <sub>3</sub> , P3 <sub>2</sub> , P3 <sub>1</sub> , and P3 <sub>0</sub> work as timer 4 overflow signal divided by 2 output pin (T), INT <sub>2</sub> pin, X <sub>CIN</sub> and X <sub>COUT</sub> pins, respectively.
	EPROM	Input port P3	Input	Connect to 0V.
SEG <sub>12</sub> /P4 <sub>3</sub> } SEG <sub>15</sub> /P4 <sub>0</sub>	Single-chip	Segment output /input port P4	Output /Input	SEG <sub>12</sub> ~SEG <sub>15</sub> are segment output pins. Also these work as input port P4 by 2-bit unit.
	EPROM	Input port P4	Input	Connect to V <sub>CC</sub> .
P5 <sub>0</sub> ~P5 <sub>7</sub>	Single-chip	I/O port P5	I/O	Port P5 is an 8-bit I/O port and has basically the same function as P1. P5 <sub>0</sub> , P5 <sub>1</sub> , P5 <sub>2</sub> and P5 <sub>3</sub> are in common with INT <sub>3</sub> , timer3 input, timer5 input and A-D trigger input, respectively.
	EPROM	Select mode	Input	P5 <sub>2</sub> , P5 <sub>1</sub> , P5 <sub>0</sub> work as $\overline{CE}$ , $\overline{OE}$ and PGM, respectively. Connect to P5 <sub>5</sub> ~P5 <sub>7</sub> to 0V, and P5 <sub>3</sub> ~P5 <sub>4</sub> to V <sub>CC</sub> .

**PIN DESCRIPTION (Continued)**

Pin	Mode	Name	Input/ Output	Functions
V <sub>L1</sub> ~V <sub>L3</sub>	Single-chip	Voltage input for LCD	Input	These are voltage input pins for LCD. Supply voltage as $0V \leq V_{L1} \leq V_{L2} \leq V_{L3} \leq V_{CC}$ . $0 \sim V_{L3}V$ is supplied to LCD.
	EPROM	Voltage input for LCD	Input	Connect to V <sub>CC</sub>
COM <sub>0</sub> ~ COM <sub>3</sub>	Single-chip	Common output	Output	These are LCD common output pins.
	EPROM	Common output	Output	Connect to V <sub>CC</sub>
SEG <sub>0</sub> ~ SEG <sub>11</sub>	Single-chip	Segment output	Output	These are LCD segment output pins.
	EPROM	Segment output	Output	Connect to V <sub>CC</sub>
SEG <sub>16</sub> /IN <sub>7</sub> } SEG <sub>23</sub> /IN <sub>0</sub>	Single-chip	Segment output /analog input	I/O	SEG <sub>16</sub> ~SEG <sub>23</sub> work as analog input pins IN <sub>7</sub> ~IN <sub>0</sub> . SEG <sub>16</sub> ~SEG <sub>19</sub> are used by 2-bit unit and SEG <sub>20</sub> ~SEG <sub>23</sub> by 4-bit unit.
	EPROM	Analog input	Input	Connect to V <sub>CC</sub>
AV <sub>SS</sub>	Single-chip	Analog voltage input	Input	GND input pin for the A-D converter.
	EPROM	Analog voltage input	Input	Connect to V <sub>SS</sub>
V <sub>REF</sub>	Single-chip	Reference voltage input	Input	Reference input pin for A-D converter.
	EPROM	Reference voltage input	Input	Connect to V <sub>CC</sub>

# M37410E6HXXXFP M37410E6HFS

## PROM VERSION of M37410M3HXXXFP, M37410M4HXXXFP, M37410M6HXXXFP

### EPROM MODE

The M37410E6HXXXFP, M37410E6HFS feature an EPROM mode in addition to its normal modes. When the RESET signal level is low ("L"), the chip automatically enters the EPROM mode. Table 1 list the correspondence between pins and Figure 1, Figure 2 give the pin connections in the EPROM mode. When in the EPROM mode, ports P0, P1, P2, P5<sub>0</sub> ~ P5<sub>2</sub>, and CNV<sub>SS</sub> are used for the PROM (equivalent to the M5L27128). When in this mode, the built-in PROM can be written to or read from using these pins in the same way as with the M5L27128. The oscillator should be connected to the X<sub>IN</sub> and X<sub>OUT</sub> pins, or external clock should be connected to the X<sub>IN</sub> pin.

Table 1. Pin function in EPROM mode

	M37410E6HXXXFP, M37410E6HFS	M5L27128
V <sub>CC</sub>	V <sub>CC</sub>	V <sub>CC</sub>
V <sub>PP</sub>	CNV <sub>SS</sub> /V <sub>PP</sub>	V <sub>PP</sub>
V <sub>SS</sub>	V <sub>SS</sub>	V <sub>SS</sub>
Address input	Ports P0, P1 <sub>0</sub> ~P1 <sub>5</sub>	A <sub>0</sub> ~A <sub>13</sub>
Data I/O	Port P2	D <sub>0</sub> ~D <sub>7</sub>
CE	P5 <sub>2</sub> /CE	CE
OE	P5 <sub>1</sub> /OE	OE
PGM	P5 <sub>0</sub> /PGM	PGM

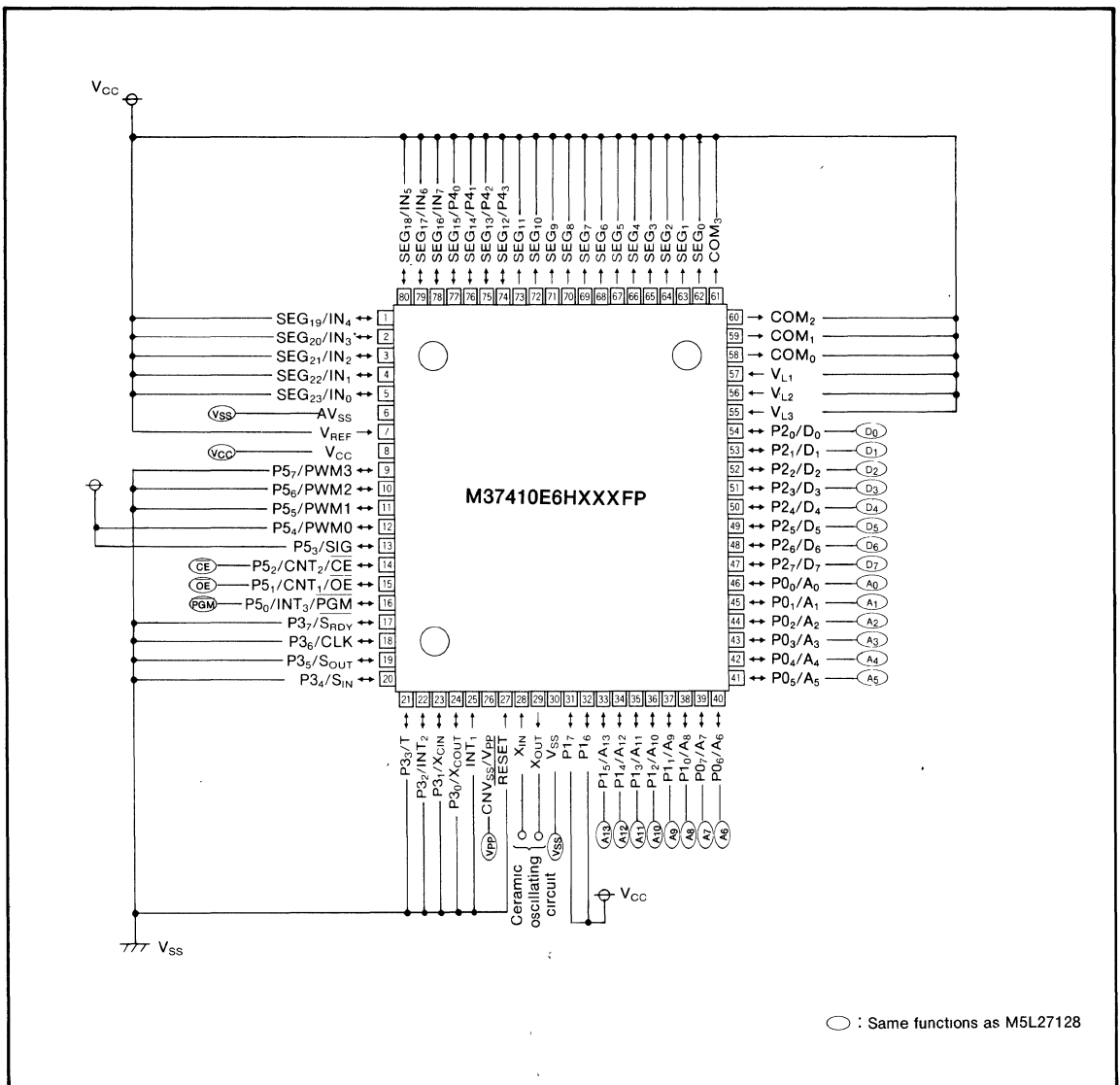

○ : Same functions as M5L27128

Fig.1 Pin connection in EPROM mode

**M37410E6HXXFP**  
**M37410E6HFS**

**PROM VERSION of M37410M3HXXFP, M37410M4HXXFP, M37410M6HXXFP**

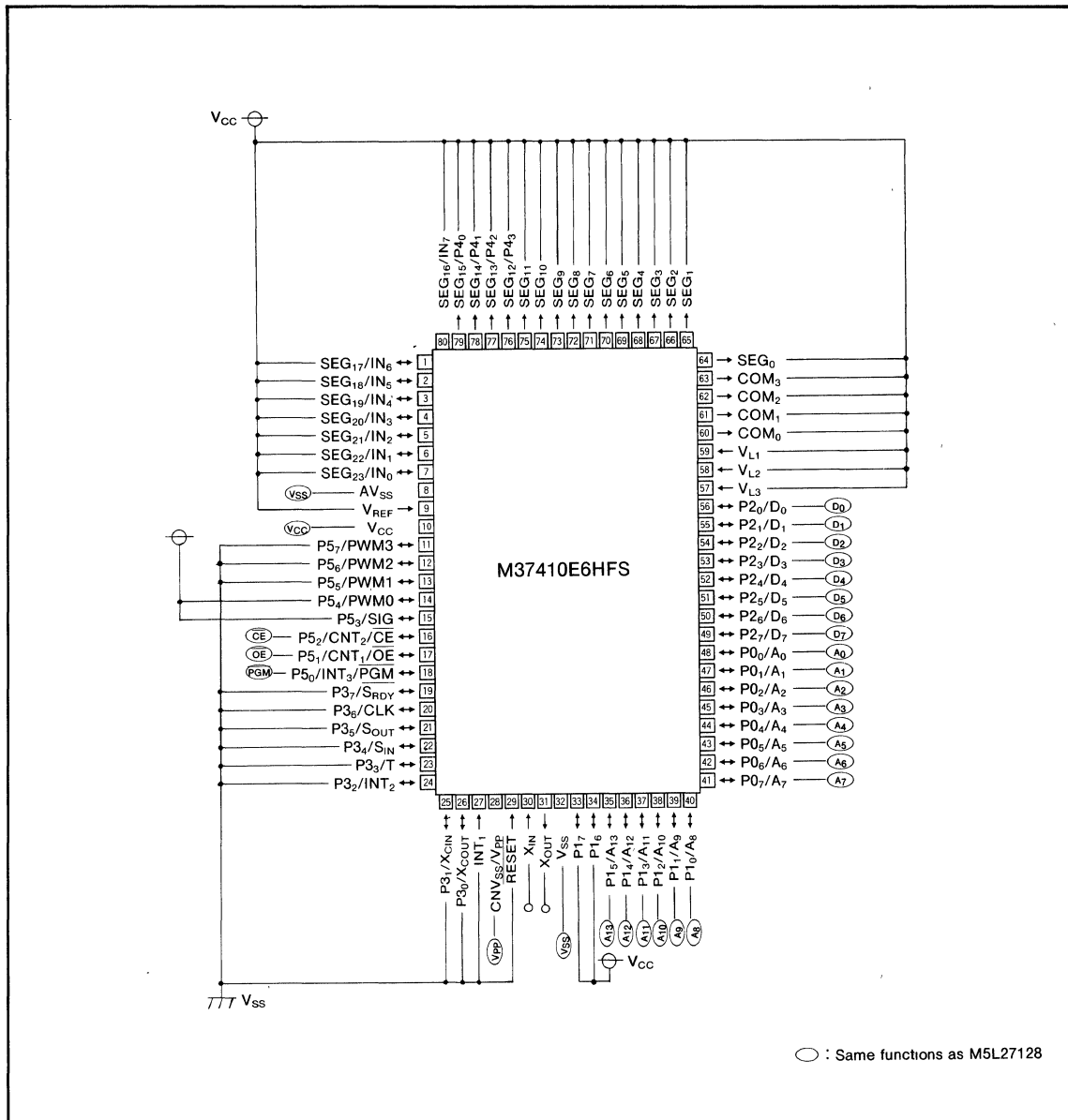

Fig.2 Pin connection in EPROM mode

**PROM VERSION of M37410M3HXXXFP, M37410M4HXXXFP, M37410M6HXXXFP**

**PROM READING, WRITING AND ERASING**  
**Reading**

To read the PROM, set the  $\overline{CE}$  and  $\overline{OE}$  pins to a "L" level, and the  $\overline{PGM}$  pin to a "H" level. Input the address of the data ( $A_0 \sim A_{13}$ ) to be read and the data will be output to the I/O pins  $D_0 \sim D_7$ . The data I/O pins will be floating when either the  $\overline{CE}$  or  $\overline{OE}$  pins are in the "H" state.

**Writing**

To write to the PROM, set the  $\overline{CE}$  pin to a "L" level and the  $\overline{OE}$  pin to a "H" level. The CPU will enter the program mode when  $V_{PP}$  is applied to the  $V_{PP}$  pin. The address to be written to is selected with pins  $A_0 \sim A_{13}$ , and the data to be written is input to pins  $D_0 \sim D_7$ . Set the  $\overline{PGM}$  pin to a "L" level to begin writing.

**Erasing**

Data can only be erased on the M37410E6HFS ceramic package, which includes a window. To erase data on this chip, use an ultraviolet light source with a 2537 Angstrom wave length. The minimum radiation power necessary for erasing is  $15W \cdot s/cm^2$ .

**Functional differences from M37410M3HXXXFP or M37410M4HXXXFP, M37410M6HXXXFP**  
(excluding characteristic differences).

	M37410M3HXXXFP M37410M4HXXXFP M37410M6HXXXFP	M37410E6HXXXFP M37410E6HFS
Port P0 pull-up resistor	Option	Not provided
Port P1 pull-up resistor	Option	Not provided
Port P2 pull-up resistor	Option	Not provided
Port P3 pull-up resistor	Option	Not provided
Port P4 pull-up resistor	Option	Not provided
Port P5 pull-up resistor	Option	Not provided
Port P2 key on wake up	Option	Provided (all bits)

**NOTES ON HANDLING**

- (1) Sunlight and fluorescent light contain wave lengths capable of erasing data. For ceramic package types, cover the transparent window with a seal (provided) when this chip is in use. However, this seal must not contact the lead pins.

**Table 2. I/O signal in each mode**

Mode \ Pin	$\overline{CE}(14)$	$\overline{OE}(15)$	$\overline{PGM}(16)$	$V_{PP}(26)$	$V_{CC}(8)$	Data I/O (47~54)
Read-out	$V_{IL}$	$V_{IL}$	$V_{IH}$	$V_{CC}$	$V_{CC}$	Output
Programming	$V_{IL}$	$V_{IH}$	Pulse ( $V_{IH} \rightarrow V_{IL}$ )	$V_{PP}$	$V_{CC}$	Input
Programming verify	$V_{IL}$	$V_{IL}$	$V_{IH}$	$V_{PP}$	$V_{CC}$	Output
Program disable	$V_{IH}$	X	X	$V_{PP}$	$V_{CC}$	Floating

Note 1 :  $V_{IL}$  and  $V_{IH}$  indicate a "L" and "H" input voltage, respectively.  
2 : An X indicates either  $V_{IL}$  or  $V_{IH}$

- (2) Before erasing, the glass should be cleaned and stains such as finger prints should be removed thoroughly. If these stains are not removed, complete erasure of the data could be prevented.
- (3) Since a high voltage (21V) is used to write data, care should be taken when turning on the PROM writer's power.
- (4) Note that ports P3<sub>0</sub> and P3<sub>1</sub> of M37410E6HXXXFP or M37410E6HFS can not use as I/O ports when the external A-D start enable bit is set to "1" (enabled). This is because that bit 5 of the serial I/O mode register of M37410M3HXXXFP or M37410M4HXXXFP, M37410M6HXXXFP acts differently from that of M37410E6HXXXFP or M37410E6HFS, as compared in the table. Bit 5 of serial I/O mode register when external A-D start enable bit is "1".

	Bit 5 of serial I/O mode register
M37410M3HXXXFP M37410M4HXXXFP M37410M6HXXXFP	Not affected
M37410E6HXXXFP M37410E6HFS	Automatically set to "1", and is fixed to "1" while external A-D start enable bit remains "1"

- (5) For the programmable microcomputer (shipped in blank or OTP type), Mitsubishi does not perform PROM write test and screening in the assembly process and following processes. To improve reliability after write, performing write and test according to the flow below before use is recommended.

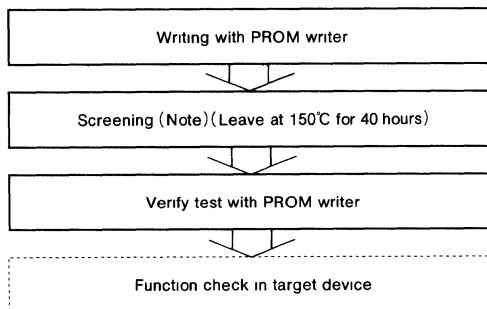

Note : Since the screening temperature is higher than storage temperature, never expose to 150°C exceeding 100 hours.



**PROM VERSION of M37410M3HXXXFP, M37410M4HXXXFP, M37410M6HXXXFP**

**ABSOLUTE MAXIMUM RATINGS**

Symbol	Parameter	Conditions	Ratings	Unit
V <sub>CC</sub>	Supply voltage		-0.3~7	V
V <sub>I</sub>	LCD supply V <sub>L1</sub> ~V <sub>L3</sub>	V <sub>L1</sub> <V <sub>L2</sub> <V <sub>L3</sub>	-0.3~V <sub>CC</sub> +0.3	V
V <sub>I</sub>	Input voltage P <sub>0</sub> ~P <sub>07</sub> , P <sub>2</sub> <sub>0</sub> ~P <sub>27</sub> , P <sub>3</sub> <sub>0</sub> , P <sub>3</sub> <sub>1</sub> , P <sub>4</sub> <sub>0</sub> ~P <sub>4</sub> <sub>3</sub> , IN <sub>0</sub> ~IN <sub>7</sub> , V <sub>REF</sub> , X <sub>IN</sub>		-0.3~V <sub>CC</sub> +0.3	V
V <sub>I</sub>	Input voltage CNV <sub>SS</sub> . (Note 1)		-0.3~7	V
V <sub>I</sub>	Input voltage INT <sub>1</sub> , RESET, P <sub>1</sub> <sub>0</sub> ~P <sub>17</sub> , P <sub>3</sub> <sub>2</sub> ~P <sub>37</sub> , P <sub>5</sub> <sub>0</sub> ~P <sub>57</sub>		-0.3~10	V
V <sub>O</sub>	Output voltage P <sub>0</sub> <sub>0</sub> ~P <sub>07</sub> , P <sub>2</sub> <sub>0</sub> ~P <sub>27</sub> , P <sub>3</sub> <sub>0</sub> , P <sub>3</sub> <sub>1</sub> , COM <sub>0</sub> ~COM <sub>3</sub> , SEG <sub>0</sub> ~SEG <sub>23</sub> , X <sub>OUT</sub>		-0.3~V <sub>CC</sub> +0.3	V
V <sub>O</sub>	Output voltage P <sub>1</sub> <sub>0</sub> ~P <sub>17</sub> , P <sub>3</sub> <sub>2</sub> ~P <sub>37</sub> , P <sub>5</sub> <sub>0</sub> ~P <sub>57</sub>		-0.3~10	V
P <sub>d</sub>	Power dissipation	T <sub>a</sub> = 25°C	300	mW
T <sub>opr</sub>	Operating temperature		-10~70	°C
T <sub>stg</sub>	Storage temperature		-40~125	°C

Note 1 : In PROM programming mode, CNV<sub>SS</sub> is 21.0V

**RECOMMENDED OPERATING CONDITIONS** (V<sub>CC</sub>=5V±5%, T<sub>a</sub>=-10~70°C, unless otherwise noted)

Symbol	Parameter	Conditions	Limits			Unit
			Min	Typ	Max	
V <sub>CC</sub>	Supply voltage (Note 1)	f(X <sub>IN</sub> )=8MHz High-speed mode f(X <sub>IN</sub> )=8MHz Normal mode or f(X <sub>IN</sub> )=2MHz High-speed mode (Note 2)	4.5 (Note 3)		5.5	V
V <sub>SS</sub>	Supply voltage			0		V
V <sub>IH</sub>	"H" input voltage P <sub>0</sub> <sub>0</sub> ~P <sub>07</sub> , P <sub>3</sub> <sub>0</sub> , P <sub>3</sub> <sub>1</sub> , P <sub>4</sub> <sub>0</sub> ~P <sub>4</sub> <sub>3</sub> , X <sub>IN</sub> , CNV <sub>SS</sub> (Note 4)		0.7V <sub>CC</sub>		V <sub>CC</sub>	V
V <sub>IH</sub>	"H" input voltage P <sub>2</sub> <sub>0</sub> ~P <sub>27</sub>		0.8V <sub>CC</sub>		V <sub>CC</sub>	V
V <sub>IH</sub>	"H" input voltage P <sub>1</sub> <sub>0</sub> ~P <sub>17</sub> , P <sub>5</sub> <sub>1</sub> ~P <sub>57</sub> , S <sub>IN</sub>		0.7V <sub>CC</sub>		10	V
V <sub>IH</sub>	"H" input voltage P <sub>5</sub> <sub>0</sub> , INT <sub>1</sub> , INT <sub>2</sub> , INT <sub>3</sub> , P <sub>3</sub> <sub>2</sub> ~P <sub>37</sub> , CNT <sub>1</sub> , CNT <sub>2</sub> , SIG, CLK		0.8V <sub>CC</sub>		10	V
V <sub>IH</sub>	"H" input voltage RESET, X <sub>CIN</sub>		0.85V <sub>CC</sub>		10	V
V <sub>IL</sub>	"L" input voltage P <sub>0</sub> <sub>0</sub> ~P <sub>07</sub> , P <sub>1</sub> <sub>0</sub> ~P <sub>17</sub> , P <sub>3</sub> <sub>0</sub> , P <sub>3</sub> <sub>1</sub> , P <sub>4</sub> <sub>0</sub> ~P <sub>4</sub> <sub>3</sub> , P <sub>5</sub> <sub>1</sub> ~P <sub>57</sub> , S <sub>IN</sub>		0		0.25V <sub>CC</sub>	V
V <sub>IL</sub>	"L" input voltage P <sub>2</sub> <sub>0</sub> ~P <sub>27</sub> , P <sub>3</sub> <sub>2</sub> ~P <sub>37</sub> , P <sub>5</sub> <sub>0</sub> , INT <sub>1</sub> , INT <sub>2</sub> , INT <sub>3</sub> , CNT <sub>1</sub> , CNT <sub>2</sub> , SIG, CLK		0		0.2V <sub>CC</sub>	V
V <sub>IL</sub>	"L" input voltage RESET, X <sub>IN</sub> , X <sub>CIN</sub>		0		0.15V <sub>CC</sub>	V
I <sub>OH</sub>	"H" output current P <sub>0</sub> <sub>0</sub> ~P <sub>07</sub> , P <sub>2</sub> <sub>0</sub> ~P <sub>27</sub> , X <sub>OUT</sub> (Note 5)				-1	mA
I <sub>OL</sub>	"L" output current P <sub>0</sub> <sub>0</sub> ~P <sub>07</sub> , P <sub>2</sub> <sub>0</sub> ~P <sub>27</sub> , P <sub>3</sub> <sub>0</sub> ~P <sub>37</sub> , P <sub>5</sub> <sub>0</sub> ~P <sub>57</sub> , X <sub>OUT</sub> , PWM <sub>0</sub> ~PWM <sub>3</sub> , T, S <sub>OUT</sub> , CLK, S <sub>RDY</sub> , SIG (Note 6)				1	mA
I <sub>OL</sub>	"L" output current P <sub>1</sub> <sub>0</sub> ~P <sub>17</sub> (Note 2)(Note 7)	V <sub>CC</sub> =3V V <sub>CC</sub> =5V			10 20	mA
f(X <sub>IN</sub> )	Clock oscillating frequency		0.2		8.2	MHz
f(X <sub>CIN</sub> )	Clock oscillating frequency for clock function		30		50	kHz

- Note 1 : When only maintaining the RAM data, minimum value of V<sub>CC</sub> is 2V.  
 2 : We say the high-speed mode, when the system clock is chosen X<sub>IN</sub>/4, and the normal mode, when the system clock is chosen X<sub>IN</sub>/16  
 3 : In case M37410E6HFS, 4.5V  
 4 : When P<sub>3</sub> is X<sub>CIN</sub> mode, the limits of V<sub>IH</sub> of P<sub>3</sub> is 0.85V<sub>CC</sub>≤V<sub>IH</sub>≤V<sub>CC</sub>, 0≤V<sub>IL</sub>≤0.15V<sub>CC</sub>  
 5 : Total of I<sub>OH</sub>(peak) of ports P<sub>0</sub>, P<sub>2</sub> and X<sub>OUT</sub> is less than 35mA  
 6 : Total of I<sub>OL</sub>(peak) of ports P<sub>0</sub>, P<sub>2</sub>, P<sub>3</sub> and P<sub>5</sub> is less than 32mA  
 7 : Total of I<sub>OL</sub>(peak) of P<sub>1</sub> is less than 80mA  
 Total of I<sub>OL</sub>(avg) of P<sub>1</sub> is less than 40mA

**PROM VERSION of M37410M3HXXXFP, M37410M4HXXXFP, M37410M6HXXXFP**

**ELECTRICAL CHARACTERISTICS** ( $T_a = -10 \sim 70^\circ\text{C}$ ,  $V_{SS} = 0\text{V}$ , unless otherwise noted)

Symbol	Parameter	Test conditions	Limits			Unit	
			Min	Typ.	Max.		
$V_{OH}$	"H" output voltage $P0_0 \sim P0_7, P2_0 \sim P2_7$	$V_{CC} = 5\text{V}, I_{OH} = -0.5\text{mA}$	4			V	
$V_{OH}$	"H" output voltage $X_{OUT}$	$V_{CC} = 5\text{V}, I_{OH} = -0.3\text{mA}$	4			V	
$V_{OL}$	"L" output voltage $P0_0 \sim P0_7, P2_0 \sim P2_7, P3_0 \sim P3_7, P5_0 \sim P5_7, T, S_{OUT}, CLK, \overline{S_{RDY}}, SIG, PWM0 \sim PWM3$	$V_{CC} = 5\text{V}, I_{OL} = 1\text{mA}$			1	V	
$V_{OL}$	"L" output voltage $P1_0 \sim P1_7$	$V_{CC} = 5\text{V}, I_{OL} = 20\text{mA}$			2	V	
$V_{OL}$	"L" output voltage $X_{OUT}$	$V_{CC} = 5\text{V}, I_{OL} = 0.3\text{mA}$			1	V	
$V_{T+} - V_{T-}$	Hysteresis $INT_1, INT_2, INT_3, CLK, CNT_1, CNT_2, SIG, S_{IN}, P2_0 \sim P2_7, X_{CIN}$	$V_{CC} = 5\text{V}$		0.7		V	
$V_{T+} - V_{T-}$	Hysteresis $\overline{RESET}$	$V_{CC} = 5\text{V}$		2		V	
$V_{T+} - V_{T-}$	Hysteresis $X_{IN}$	$V_{CC} = 5\text{V}$		0.5		V	
$I_{IL}$	"L" input current $P0_0 \sim P0_7, P1_0 \sim P1_7, P2_0 \sim P2_7, P3_0 \sim P3_7, P4_0 \sim P4_3, P5_0 \sim P5_7$ (Note 1), $IN_0 \sim IN_7, INT_1, \overline{RESET}, X_{IN}$	$V_{CC} = 5\text{V}$ $V_I = 0\text{V}$			-5	$\mu\text{A}$	
$I_{IH}$	"H" input current $P0_0 \sim P0_7, P2_0 \sim P2_7, P3_0, P3_1, P4_0 \sim P4_7, IN_0 \sim IN_7, X_{IN}, X_{CIN}, CNV_{SS}$	$V_{CC} = 5\text{V}$ $V_I = 5\text{V}$			5	$\mu\text{A}$	
$I_{IH}$	"H" input current $P1_0 \sim P1_7, P3_0 \sim P3_7, P5_0 \sim P5_7, INT_1, INT_2, INT_3, CNT_1, CNT_2, SIG, \overline{RESET}, S_{IN}, CLK$	$V_I = 10\text{V}$			10	$\mu\text{A}$	
$R_{COM}$	Output impedance $COM_0 \sim COM_3$	$V_{L1} = V_{CC}/3$ $V_{L2} = 2V_{L1}$ $V_{L3} = V_{CC}$ Other COM, SEG pins are opened	$V_{CC} = 5\text{V}$	200		$\Omega$	
$R_S$	Output impedance $SEG_0 \sim SEG_{23}$		$V_{CC} = 5\text{V}$	2		k $\Omega$	
$I_{CC}$	Supply current	at operation	$f(X_{IN}) = 8\text{MHz}$ High-speed mode $V_{CC} = 5\text{V}$		6	12	mA
		at wait state	$f(X_{CIN}) = 32\text{kHz}, V_{CC} = 5\text{V}$		30	60	
		at stop state	$V_{CC} = 5\text{V}$ , all clock stop $T_a = 25^\circ\text{C}$		0.1	1.0	$\mu\text{A}$
$V_{RAM}$	RAM retention voltage		2		5.5	V	

Note 1 : Also the same as when each pin is used as  $INT_2, INT_3, CNT_1, CNT_2, SIG, S_{IN}$  and  $X_{IN}$ , respectively.

**PROM VERSION of M37410M3HXXFP, M37410M4HXXFP, M37410M6HXXFP**

**A-D CONVERTER CHARACTERISTICS** ( $V_{CC}=5V$ ,  $V_{SS}=AV_{SS}=0V$ ,  $T_a=25^\circ C$ ,  $f(X_{IN})=8\text{ MHz}$ , unless otherwise noted)

Symbol	Parameter	Test conditions	Limits			Unit
			Min.	Typ.	Max	
—	Resolution				8	bits
—	Non-linearity error	$V_{CC}=V_{REF}=5.12V$			$\pm 2$	LSB
		$V_{CC}=V_{REF}=3.072V$			$\pm 2$	
—	Differential non-linearity	$V_{CC}=V_{REF}=5.12V$			$\pm 0.9$	LSB
		$V_{CC}=V_{REF}=3.072V$			$\pm 0.9$	
$V_{OT}$	Zero transition error	$V_{CC}=V_{REF}=5.12V$			2	LSB
		$V_{CC}=V_{REF}=3.072V$			2	
$V_{FST}$	Full-scale transition error	$V_{CC}=V_{REF}=5.12V$			6	LSB
		$V_{CC}=V_{REF}=3.072V$			10	
$T_C$	Conversion time	$V_{CC}=2.5\sim 5.5V$ High-speed mode		$200/(X_{IN})$		$\mu s$
		$V_{CC}=2.5\sim 5.5V$ Normal mode		$800/(X_{IN})$		
$I_{REF}$	Reference input current	$V_{REF}=5V$		1.0	2.5	mA
		$V_{REF}=3V$		0.5	1.5	
$I_{IN}$	Analog port input current	$V_{IN}=0\sim V_{CC}$		1	10	$\mu A$
$V_{IN}$	Analog input voltage	$V_{CC}=2.5\sim 5.5V$	$AV_{SS}$		$V_{CC}$	V
$V_{REF}$	Reference input voltage		2.5		$V_{CC}$	V