

# MITSUBISHI MICROCOMPUTERS 7536 Group

SINGLE-CHIP 8-BIT CMOS MICROCOMPUTER

## DESCRIPTION

The 7536 Group is the 8-bit microcomputer based on the 740 family core technology.

The 7536 Group has a USB, 8-bit timers, and an A-D converter, and is useful for an input device for personal computer peripherals.

## FEATURES

- Basic machine-language instructions ..... 69
- The minimum instruction execution time ..... 0.34  $\mu$ s  
(at 6 MHz oscillation frequency for the shortest instruction)
- Memory size  
ROM ..... 8K to 16K bytes  
RAM ..... 256 to 384 bytes
- Programmable I/O ports ..... 33
- Interrupts ..... 14 sources, 8 vectors
- Timers ..... 8-bit X 3

- Serial I/O1 ..... used only for Low Speed in USB  
(USB/UART)
- Serial I/O2 ..... 8-bit X 1  
(Clock-synchronized)
- A-D converter ..... 10-bit X 8 channels
- Clock generating circuit ..... Built-in type  
(connect to external ceramic resonator or quartz-crystal oscillator)
- Watchdog timer ..... 16-bit X 1
- Power source voltage  
At 6 MHz XIN oscillation frequency at ceramic resonator  
..... 4.1 to 5.5 V
- Power dissipation ..... 30 mW (standard)
- Operating temperature range ..... -20 to 85 °C

## APPLICATION

Input device for personal computer peripherals

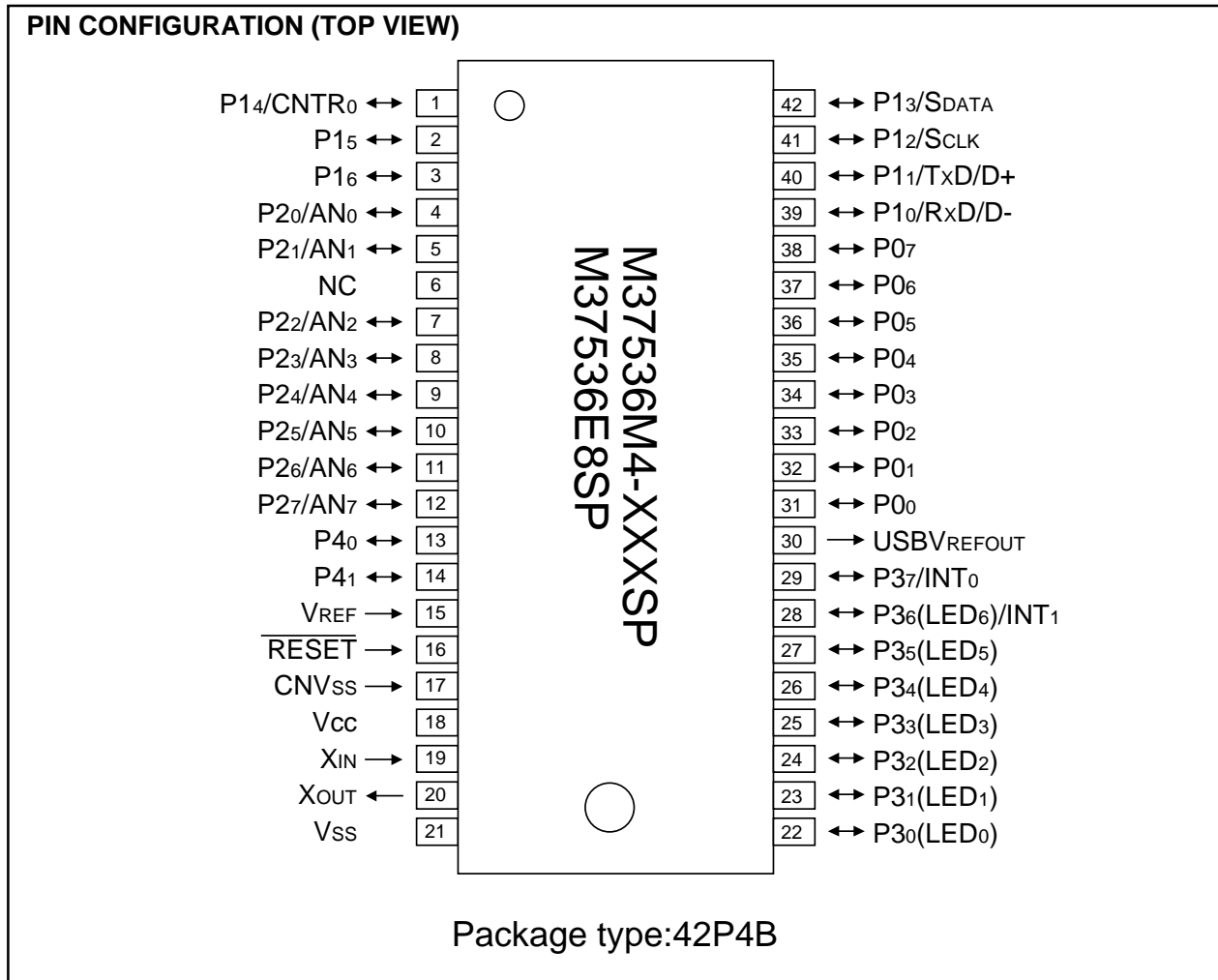

Fig. 1 Pin configuration of M37536M4-XXXSP, M37536E8SP

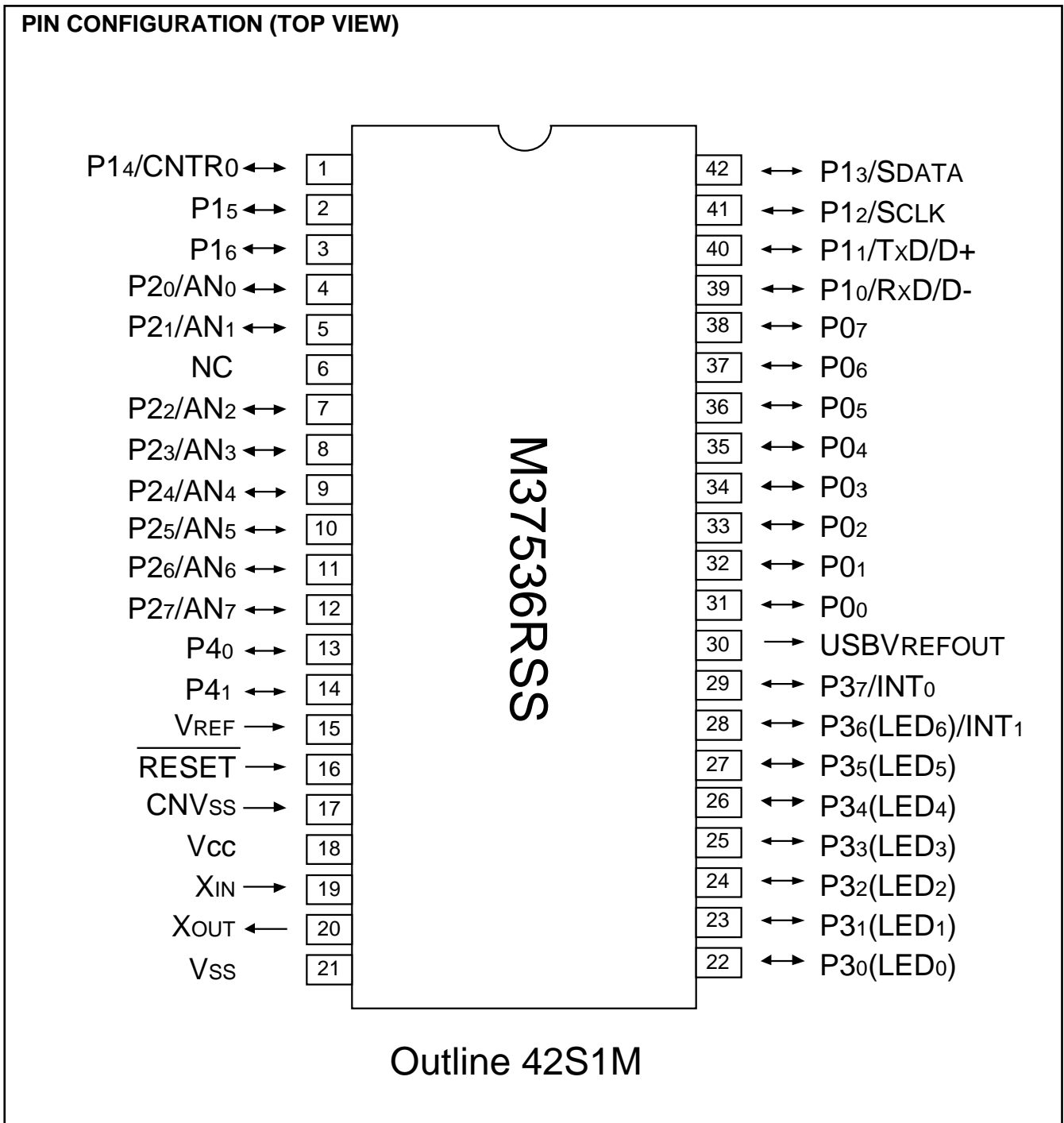

Fig. 2 Pin configuration of M37536RSS

FUNCTIONAL BLOCK

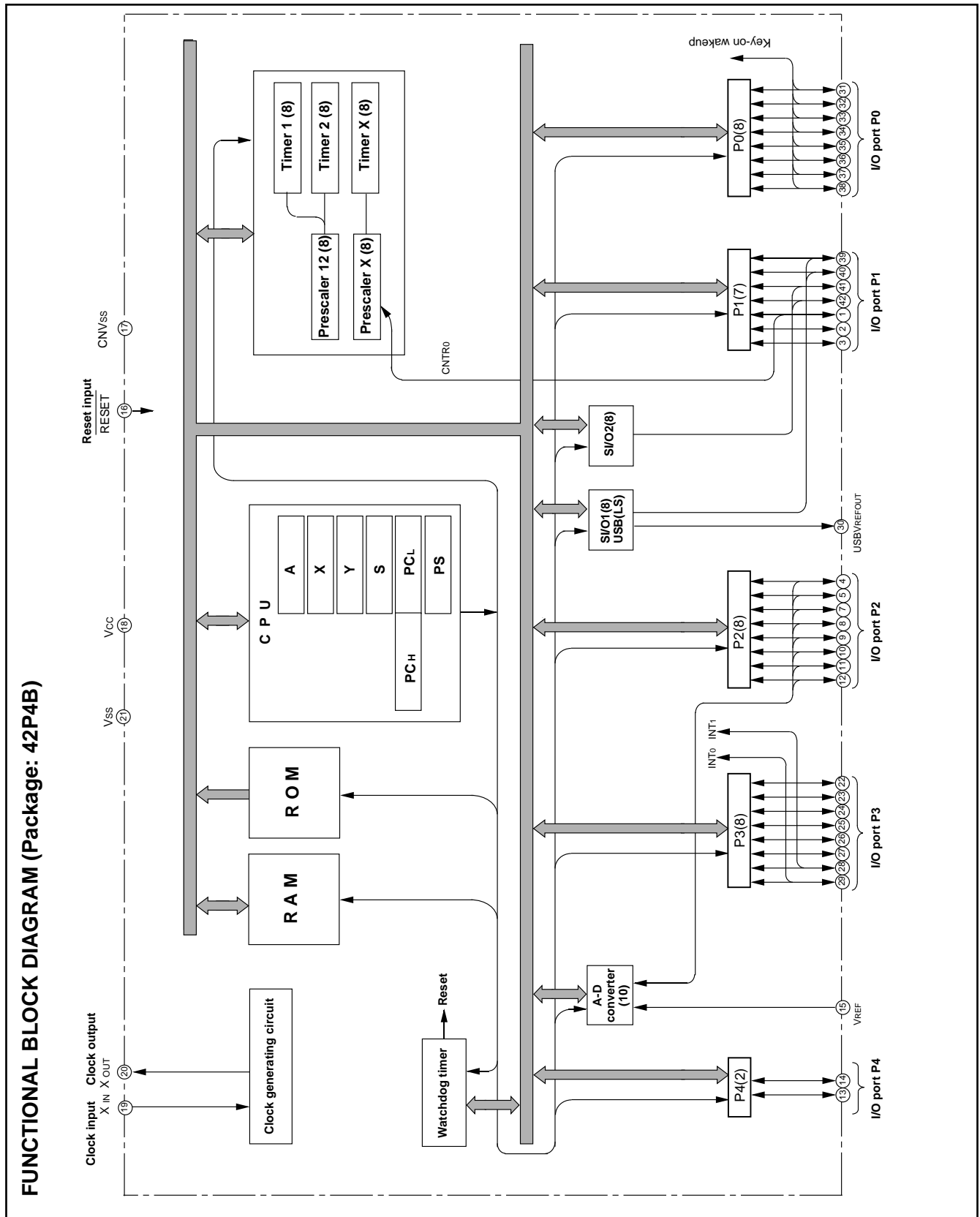

Fig. 3 Functional block diagram

## PIN DESCRIPTION

Table 1 Pin description

Pin	Name	Function	Function expect a port function
Vcc, Vss	Power source	•Apply voltage of 4.1 to 5.5 V to Vcc, and 0 V to Vss.	
VREF	Analog reference voltage	•Reference voltage input pin for A-D converter	
USBVREFOUT	USB reference voltage output	•Output pin for pulling up a D- line with 1.5 kΩ external resistor	
CNVss	CNVss	•Chip operating mode control pin, which is always connected to Vss.	
RESET	Reset input	•Reset input pin for active "L"	
XIN	Clock input	•Input and output pins for main clock generating circuit	
XOUT	Clock output	•Connect a ceramic resonator or quartz crystal oscillator between the XIN and XOUT pins. •If an external clock is used, connect the clock source to the XIN pin and leave the XOUT pin open.	
P0 <sub>0</sub> –P0 <sub>7</sub>	I/O port P0	•8-bit I/O port. •I/O direction register allows each pin to be individually programmed as either input or output. •CMOS compatible input level •CMOS 3-state output structure •Whether a built-in pull-up resistor is to be used or not can be determined by program.	•Key-input (key-on wake up interrupt input) pins
P1 <sub>0</sub> /Rx/D/ D- P1 <sub>1</sub> /Tx/D/ D+ P1 <sub>2</sub> /SCLK P1 <sub>3</sub> /SDATA P1 <sub>4</sub> /CNTR <sub>0</sub>	I/O port P1	•7-bit I/O port •I/O direction register allows each pin to be individually programmed as either input or output. •CMOS compatible input level •CMOS 3-state output structure •CMOS/TTL level can be switched for P1 <sub>0</sub> , P1 <sub>2</sub> , P1 <sub>3</sub> . •When using the USB function, input level of ports P1 <sub>0</sub> and P1 <sub>1</sub> becomes USB input level, and output level of them becomes USB output level.	•Serial I/O1 function pin •Serial I/O2 function pin •Timer X function pin
P1 <sub>5</sub> , P1 <sub>6</sub>			
P2 <sub>0</sub> /AN <sub>0</sub> – P2 <sub>7</sub> /AN <sub>7</sub>	I/O port P2	•8-bit I/O port having almost the same function as P0 •CMOS compatible input level •CMOS 3-state output structure	•Input pins for A-D converter
P3 <sub>0</sub> –P3 <sub>5</sub>	I/O port P3	•8-bit I/O port •I/O direction register allows each pin to be individually programmed as either input or output. •CMOS compatible input level (CMOS/TTL level can be switched for P3 <sub>6</sub> , P3 <sub>7</sub> ). •CMOS 3-state output structure •P3 <sub>0</sub> to P3 <sub>6</sub> can output a large current for driving LED.	
P3 <sub>6</sub> /INT <sub>1</sub> P3 <sub>7</sub> /INT <sub>0</sub>		•Whether a built-in pull-up resistor is to be used or not can be determined by program.	•Interrupt input pins
P4 <sub>0</sub> , P4 <sub>1</sub>	I/O port P4	•2-bit I/O port •I/O direction register allows each pin to be individually programmed as either input or output.	

**GROUP EXPANSION**

Mitsubishi plans to expand the 7536 group as follow:

**Memory type**

Support for Mask ROM version, One Time PROM version, and Emulator MCU .

**Memory size**

ROM/PROM size ..... 8 K to 16 K bytes  
 RAM size ..... 256 to 384 bytes

**Package**

42P4B ..... 42-pin plastic molded SDIP  
 42SIM ..... 42-pin shrink ceramic PIGGY BACK

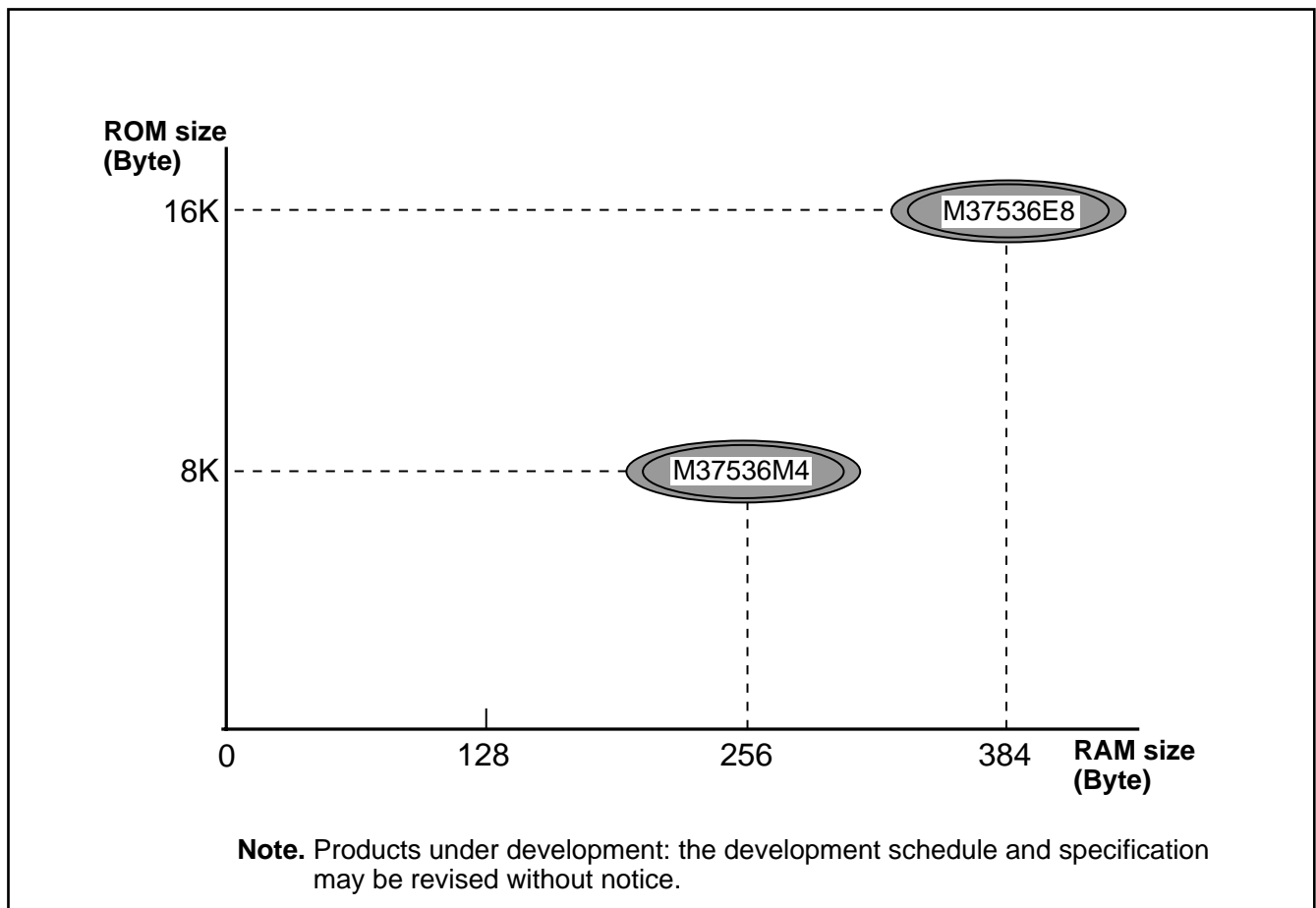

Fig. 4 Memory expansion plan

Currently supported products are listed below.

Table 2 List of supported products

Product	(P) ROM size (bytes) ROM size for User ( )	RAM size (bytes)	Package	Remarks
M37536M4-XXXSP	8192 (8062)	256	42P4B	Mask ROM version
M37536E8SP	16384 (16254)	384	42P4B	One Time PROM version (blank)
M37536RSS	—	384	42S1M	Emulator MCU

**FUNCTIONAL DESCRIPTION**  
**Central Processing Unit (CPU)**

The 7536 group uses the standard 740 family instruction set. Refer to the table of 740 family addressing modes and machine instructions or the 740 Family Software Manual for details on the instruction set.

Machine-resident 740 family instructions are as follows:

The FST and SLW instructions cannot be used.

The MUL and DIV instructions cannot be used.

The WIT and STP instructions can be used.

The central processing unit (CPU) has the six registers.

**Switching method of CPU mode register**

Switch the CPU mode register (CPUM) at the head of program after releasing Reset in the following method.

**[CPU Mode Register] CPUM**

The CPU mode register contains the stack page selection bit.

This register is allocated at address 003B<sub>16</sub>.

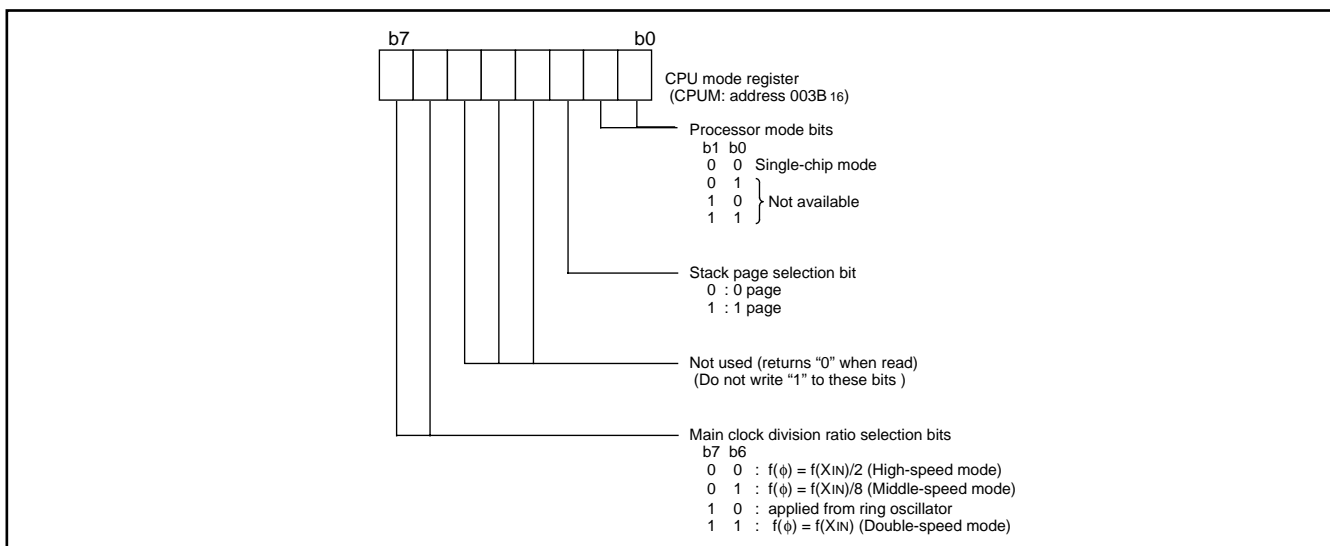

Fig. 5 Structure of CPU mode register

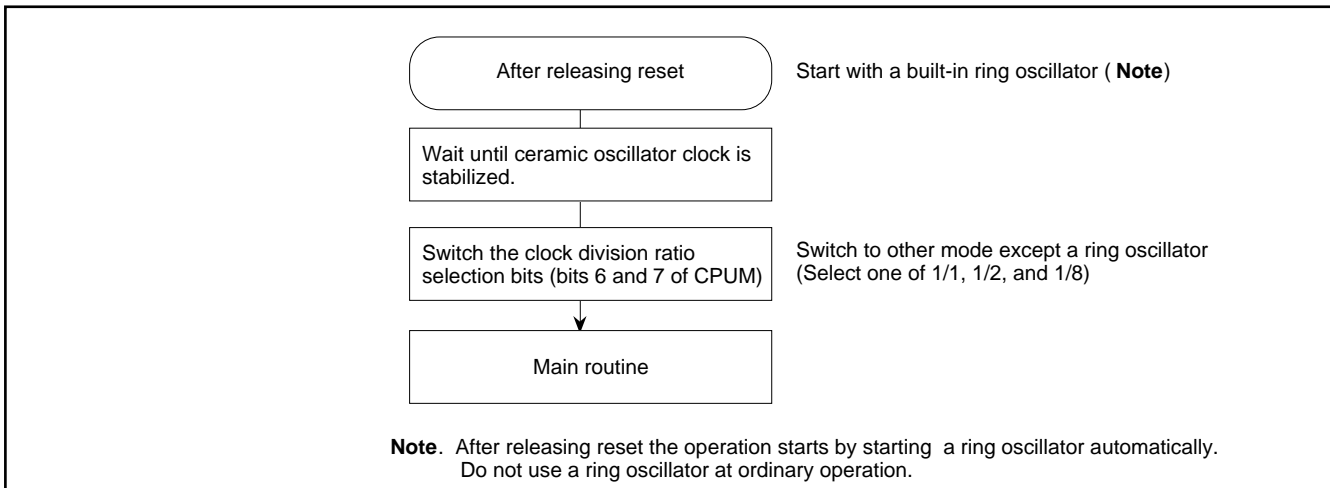

Fig. 6 Switching method of CPU mode register

**Memory**

**Special function register (SFR) area**

The SFR area in the zero page contains control registers such as I/O ports and timers.

**RAM**

RAM is used for data storage and for a stack area of subroutine calls and interrupts.

**ROM**

The first 128 bytes and the last 2 bytes of ROM are reserved for device testing and the rest is a user area for storing programs.

**Interrupt vector area**

The interrupt vector area contains reset and interrupt vectors.

**Zero page**

The 256 bytes from addresses 0000<sub>16</sub> to 00FF<sub>16</sub> are called the zero page area. The internal RAM and the special function registers (SFR) are allocated to this area.

The zero page addressing mode can be used to specify memory and register addresses in the zero page area. Access to this area with only 2 bytes is possible in the zero page addressing mode.

**Special page**

The 256 bytes from addresses FF00<sub>16</sub> to FFFF<sub>16</sub> are called the special page area. The special page addressing mode can be used to specify memory addresses in the special page area. Access to this area with only 2 bytes is possible in the special page addressing mode.

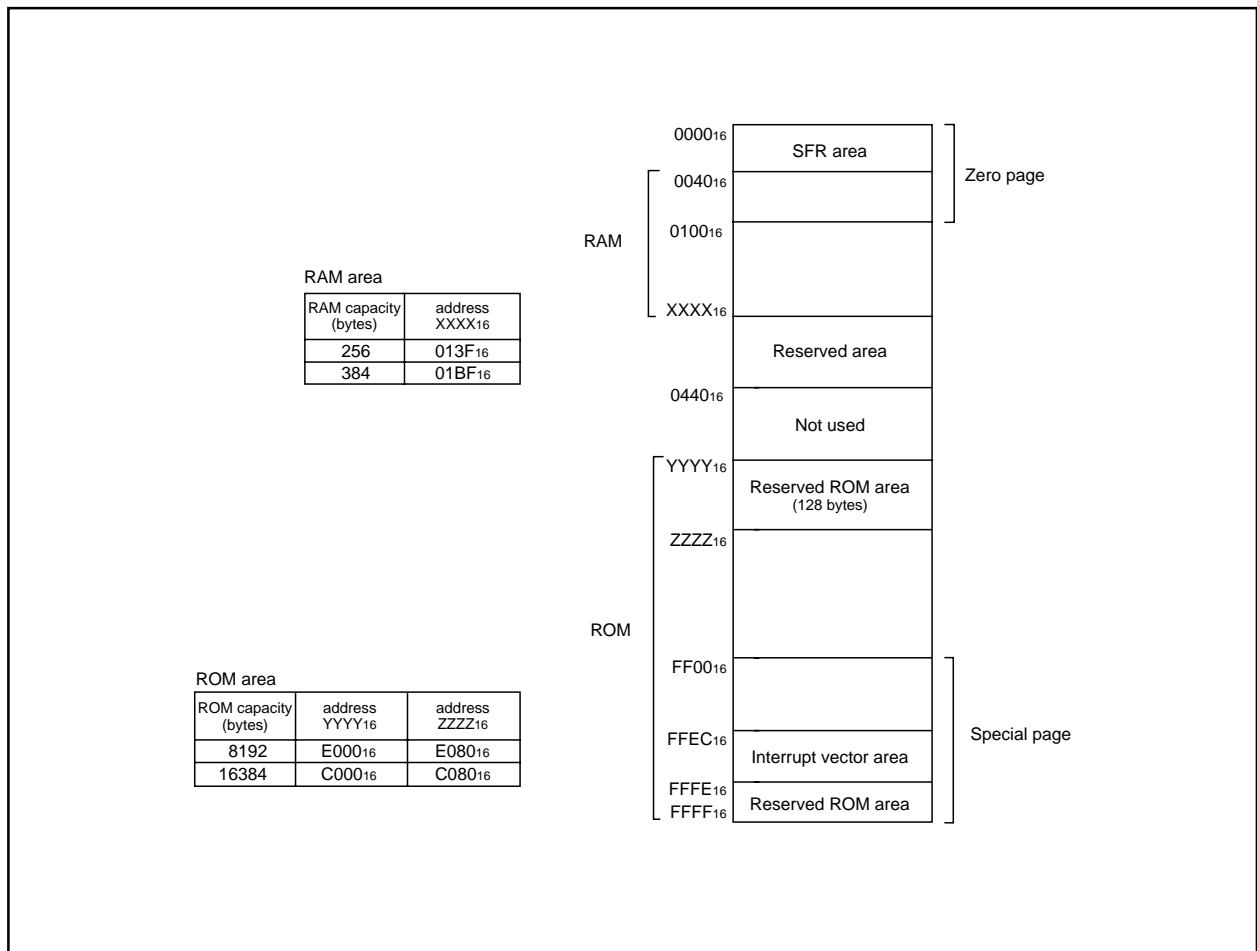

Fig. 7 Memory map diagram

0000 <sub>16</sub>	Port P0 (P0)	0020 <sub>16</sub>	USB interrupt control register (USBICON)
0001 <sub>16</sub>	Port P0 direction register (P0D)	0021 <sub>16</sub>	USB transmit data byte number set register 0 (EP0BYTE)
0002 <sub>16</sub>	Port P1 (P1)	0022 <sub>16</sub>	USB transmit data byte number set register 1 (EP1BYTE)
0003 <sub>16</sub>	Port P1 direction register (P1D)	0023 <sub>16</sub>	USBPID control register 0 (EP0PID)
0004 <sub>16</sub>	Port P2 (P2)	0024 <sub>16</sub>	USBPID control register 1 (EP1PID)
0005 <sub>16</sub>	Port P2 direction register (P2D)	0025 <sub>16</sub>	USB address register (USBA)
0006 <sub>16</sub>	Port P3 (P3)	0026 <sub>16</sub>	USB sequence bit initialization register (INISQ1)
0007 <sub>16</sub>	Port P3 direction register (P3D)	0027 <sub>16</sub>	USB control register (USBCON)
0008 <sub>16</sub>	Port P4 (P4)	0028 <sub>16</sub>	Prescaler 12 (PRE12)
0009 <sub>16</sub>	Port P4 direction register (P4D)	0029 <sub>16</sub>	Timer 1 (T1)
000A <sub>16</sub>		002A <sub>16</sub>	Timer 2 (T2)
000B <sub>16</sub>		002B <sub>16</sub>	Timer X mode register (TM)
000C <sub>16</sub>		002C <sub>16</sub>	Prescaler X (PREX)
000D <sub>16</sub>		002D <sub>16</sub>	Timer X (TX)
000E <sub>16</sub>		002E <sub>16</sub>	Timer count source set register (TCSS)
000F <sub>16</sub>		002F <sub>16</sub>	
0010 <sub>16</sub>		0030 <sub>16</sub>	Serial I/O2 control register (SIO2CON)
0011 <sub>16</sub>		0031 <sub>16</sub>	Serial I/O2 register (SIO2)
0012 <sub>16</sub>		0032 <sub>16</sub>	
0013 <sub>16</sub>		0033 <sub>16</sub>	
0014 <sub>16</sub>		0034 <sub>16</sub>	A-D control register (ADCON)
0015 <sub>16</sub>		0035 <sub>16</sub>	A-D conversion register (low-order) (ADL)
0016 <sub>16</sub>	Pull-up control register (PULL)	0036 <sub>16</sub>	A-D conversion register (high-order) (ADH)
0017 <sub>16</sub>	Port P1P3 control register (P1P3C)	0037 <sub>16</sub>	
0018 <sub>16</sub>	Transmit/Receive buffer register (TB/RB)	0038 <sub>16</sub>	MISRG
0019 <sub>16</sub>	USB status register (USBSTS)/UART status register (UARTSTS)	0039 <sub>16</sub>	Watchdog timer control register (WDTCON)
001A <sub>16</sub>	Serial I/O1 control register (SIO1CON)	003A <sub>16</sub>	Interrupt edge selection register (INTEDGE)
001B <sub>16</sub>	UART control register (UARTCON)	003B <sub>16</sub>	CPU mode register (CPUM)
001C <sub>16</sub>	Baud rate generator (BRG)	003C <sub>16</sub>	Interrupt request register 1 (IREQ1)
001D <sub>16</sub>	USB data toggle synchronization register ( TRSYNC)	003D <sub>16</sub>	
001E <sub>16</sub>	USB interrupt source discrimination register 1 (USBIR1)	003E <sub>16</sub>	Interrupt control register 1 (ICON1)
001F <sub>16</sub>	USB interrupt source discrimination register 2 (USBIR2)	003F <sub>16</sub>	

Fig. 8 Memory map of special function register (SFR)



**I/O Ports**

**[Direction registers] PiD**

The I/O ports have direction registers which determine the input/output direction of each pin. Each bit in a direction register corresponds to one pin, and each pin can be set to be input or output.

When "1" is set to the bit corresponding to a pin, this pin becomes an output port. When "0" is set to the bit, the pin becomes an input port. When data is read from a pin set to output, not the value of the pin itself but the value of port latch is read. Pins set to input are floating, and permit reading pin values.

If a pin set to input is written to, only the port latch is written to and the pin remains floating.

**[Pull-up control] PULL**

By setting the pull-up control register (address 0016<sub>16</sub>), ports P0 and P3 can exert pull-up control by program. However, pins set to output are disconnected from this control and cannot exert pull-up control.

**[Port P1P3 control] P1P3C**

By setting the port P1P3 control register (address 0017<sub>16</sub>), a CMOS input level or a TTL input level can be selected for ports P1<sub>0</sub>, P1<sub>2</sub>, P1<sub>3</sub>, P3<sub>5</sub>, P3<sub>6</sub> and P3<sub>7</sub> by program.

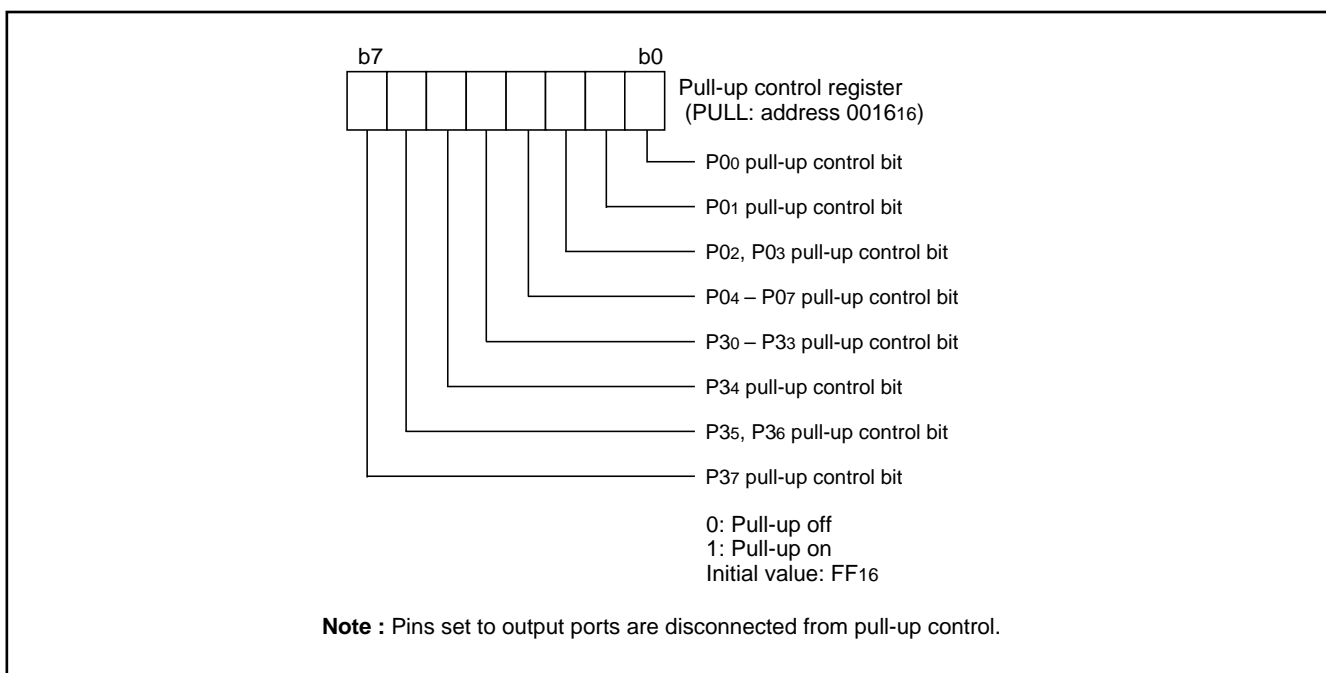

Fig. 9 Structure of pull-up control register

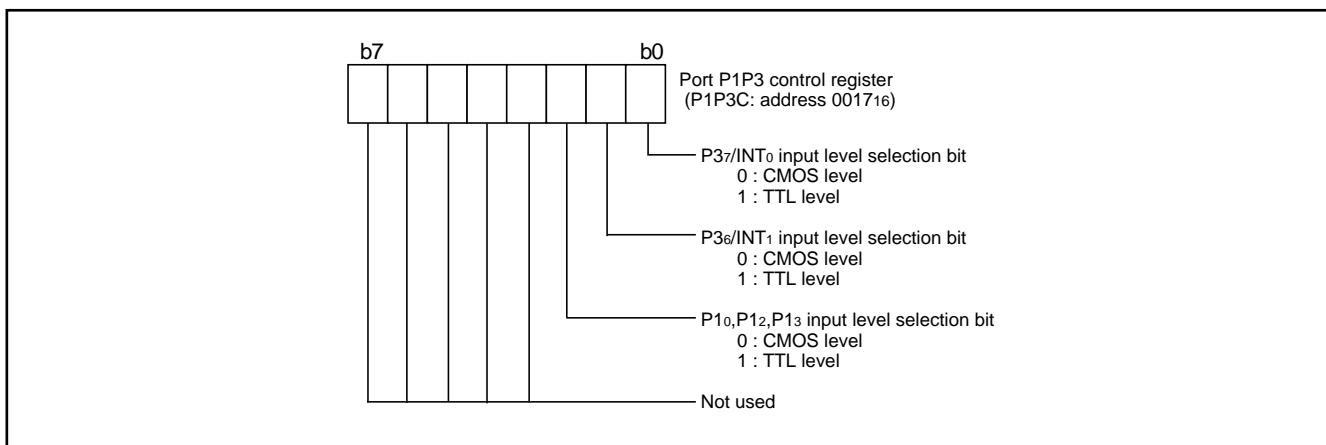

Fig. 10 Structure of port P1P3 control register

Table 3 I/O port function table

Pin	Name	Input/output	I/O format	Non-port function	Related SFRs	Diagram No.
P00–P07	I/O port P0	I/O individual bits	•CMOS compatible input level •CMOS 3-state output	Key input interrupt	Pull-up control register	(1)
P10/RxD/D- P11/TxD/D+	I/O port P1		•USB input/output level when selecting USB function •CMOS compatible input level •CMOS 3-state output (Note)	Serial I/O1 function input/output	Serial I/O1 control register	(2) (3)
P12/SCLK P13/SDATA				Serial I/O2 function input/output	Serial I/O2 control register	(4) (5)
P14/CNTR0				Timer X function input/output	Timer X mode register	(6)
P15, P16						(10)
P20/AN0– P27/AN7				I/O port P2	A-D conversion input	A-D control register
P30–P35	I/O port P3					(8)
P36/INT1 P37/INT0				External interrupt input	Interrupt edge selection register	(9)
P40, P41				I/O port P4		

Note: Port P10, P12, P13, P36, P37 is CMOS/TTL level.

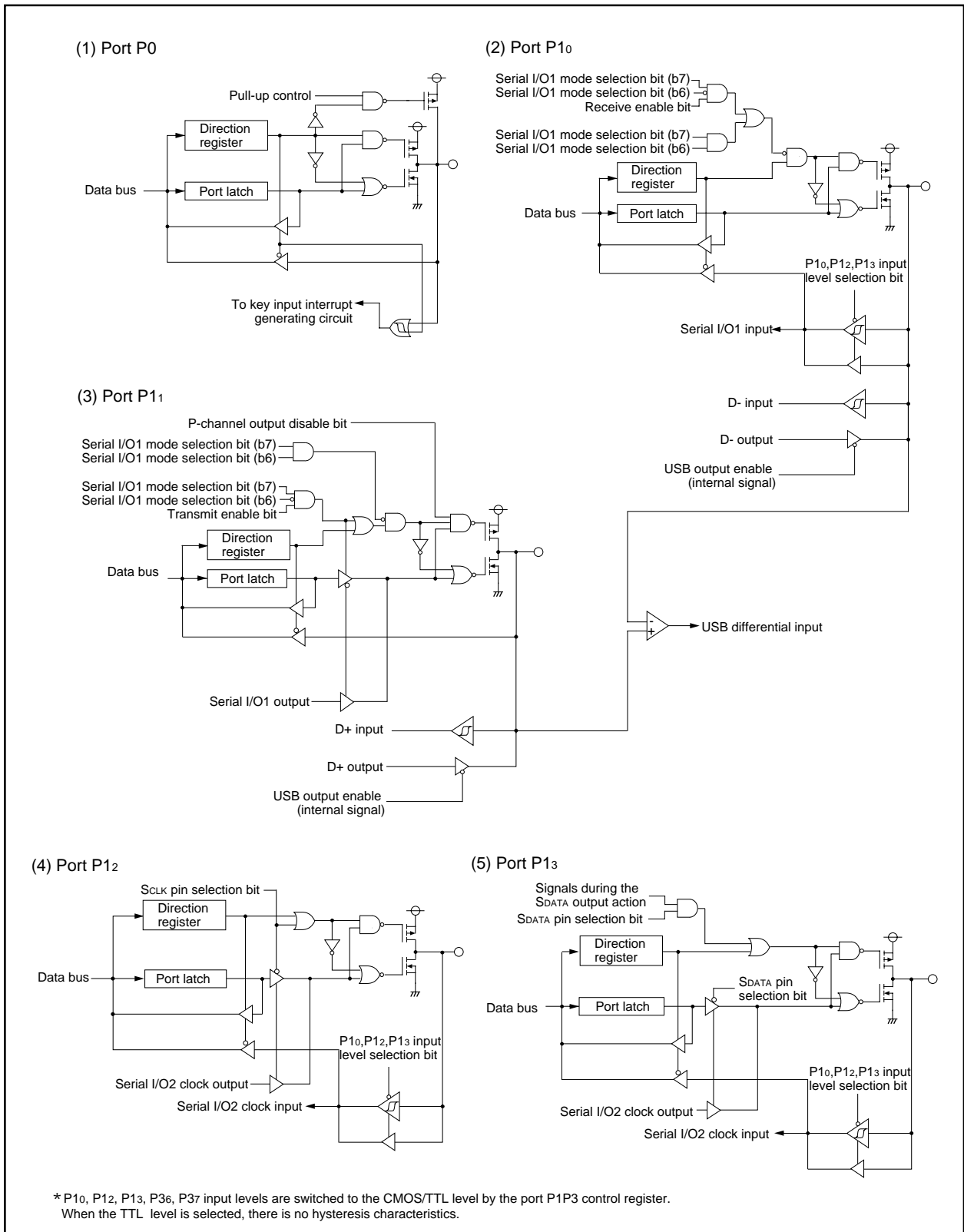

Fig. 11 Block diagram of ports (1)

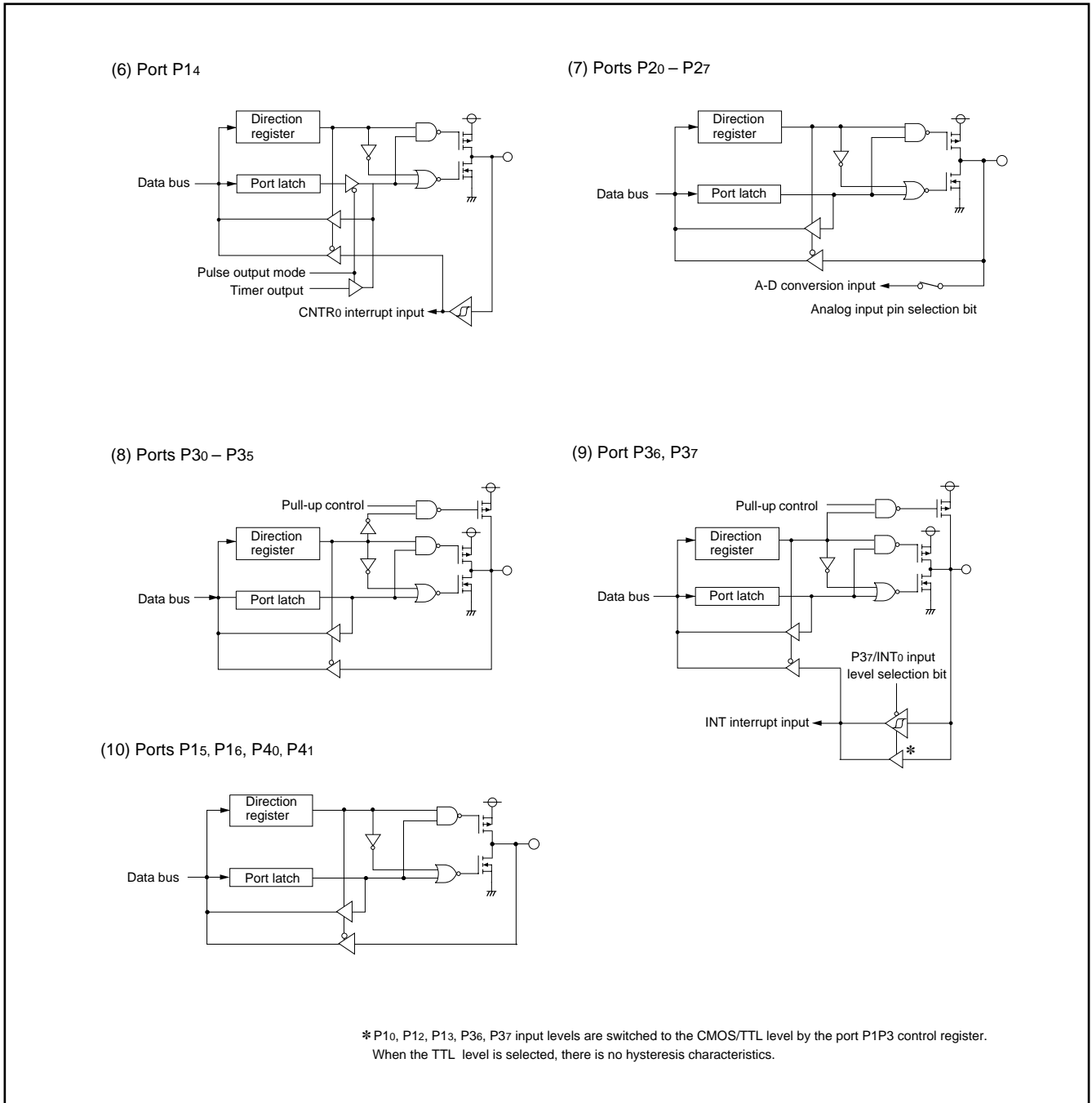

Fig. 12 Block diagram of ports (2)

## Interrupts

Interrupts occur by 14 different sources : 4 external sources, 9 internal sources and 1 software source.

### Interrupt control

All interrupts except the BRK instruction interrupt have an interrupt request bit and an interrupt enable bit, and they are controlled by the interrupt disable flag. When the interrupt enable bit and the interrupt request bit are set to "1" and the interrupt disable flag is set to "0", an interrupt is accepted.

The interrupt request bit can be cleared by program but not be set.

The interrupt enable bit can be set and cleared by program.

It becomes usable by switching CNTR<sub>0</sub> and A-D interrupt sources with bit 7 of the interrupt edge selection register, timer 2 and serial I/O<sub>2</sub> interrupt sources with bit 6, timer X and key-on wake-up interrupt sources with bit 5, and serial I/O transmit and INT<sub>1</sub> interrupt sources with bit 4.

The reset and BRK instruction interrupt can never be disabled with any flag or bit. All interrupts except these are disabled when the interrupt disable flag is set.

When several interrupts occur at the same time, the interrupts are received according to priority.

### Interrupt operation

Upon acceptance of an interrupt the following operations are automatically performed:

1. The processing being executed is stopped.
2. The contents of the program counter and processor status register are automatically pushed onto the stack.
3. The interrupt disable flag is set and the corresponding interrupt request bit is cleared.
4. Concurrently with the push operation, the interrupt destination address is read from the vector table into the program counter.

### Notes on use

When the active edge of an external interrupt (INT<sub>0</sub>, INT<sub>1</sub>, CNTR<sub>0</sub>) is set, the interrupt request bit may be set.

Therefore, please take following sequence:

1. Disable the external interrupt which is selected.
2. Change the active edge in interrupt edge selection register. (in case of CNTR<sub>0</sub>: Timer X mode register)
3. Clear the set interrupt request bit to "0".
4. Enable the external interrupt which is selected.

**Table 4 Interrupt vector address and priority**

Interrupt source	Priority	Vector addresses (Note 1)		Interrupt request generating conditions	Remarks
		High-order	Low-order		
Reset (Note 2)	1	FFFD <sub>16</sub>	FFFC <sub>16</sub>	At reset input	Non-maskable
UART receive	2	FFFB <sub>16</sub>	FFFA <sub>16</sub>	At completion of UART data receive	Valid in UART mode
USB IN token				At detection of IN token	Valid in USB mode
UART transmit	3	FFF9 <sub>16</sub>	FFF8 <sub>16</sub>	At completion of UART transmit shift or when transmit buffer is empty	Valid in UART mode
USB SETUP/OUT token				At detection of SETUP/OUT token or At detection of Reset/ Suspend/ Resume	Valid in USB mode
Reset/Suspend/Resume					
INT <sub>1</sub>				At detection of either rising or falling edge of INT <sub>1</sub> input	External interrupt (active edge selectable)
INT <sub>0</sub>	4	FFF7 <sub>16</sub>	FFF6 <sub>16</sub>	At detection of either rising or falling edge of INT <sub>0</sub> input	External interrupt (active edge selectable)
Timer X	5	FFF5 <sub>16</sub>	FFF4 <sub>16</sub>	At timer X underflow	
Key-on wake-up				At falling of conjunction of input logical level for port P0 (at input)	External interrupt (valid at falling)
Timer 1	6	FFF3 <sub>16</sub>	FFF2 <sub>16</sub>	At timer 1 underflow	STP release timer underflow
Timer 2	7	FFF1 <sub>16</sub>	FFF0 <sub>16</sub>	At timer 2 underflow	
Serial I/O <sub>2</sub>				At completion of transmit/receive shift	
CNTR <sub>0</sub>	8	FFEF <sub>16</sub>	FFEE <sub>16</sub>	At detection of either rising or falling edge of CNTR <sub>0</sub> input	External interrupt (active edge selectable)
A-D conversion				At completion of A-D conversion	
BRK instruction	9	FFED <sub>16</sub>	FFEC <sub>16</sub>	At BRK instruction execution	Non-maskable software interrupt

**Note 1:** Vector addressed contain internal jump destination addresses.

**2:** Reset function in the same way as an interrupt with the highest priority.

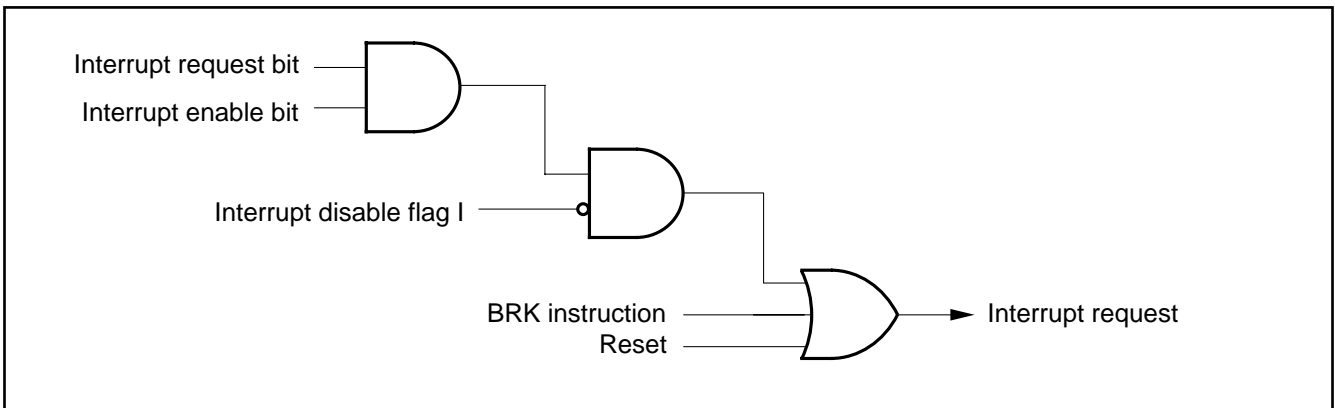

Fig. 13 Interrupt control

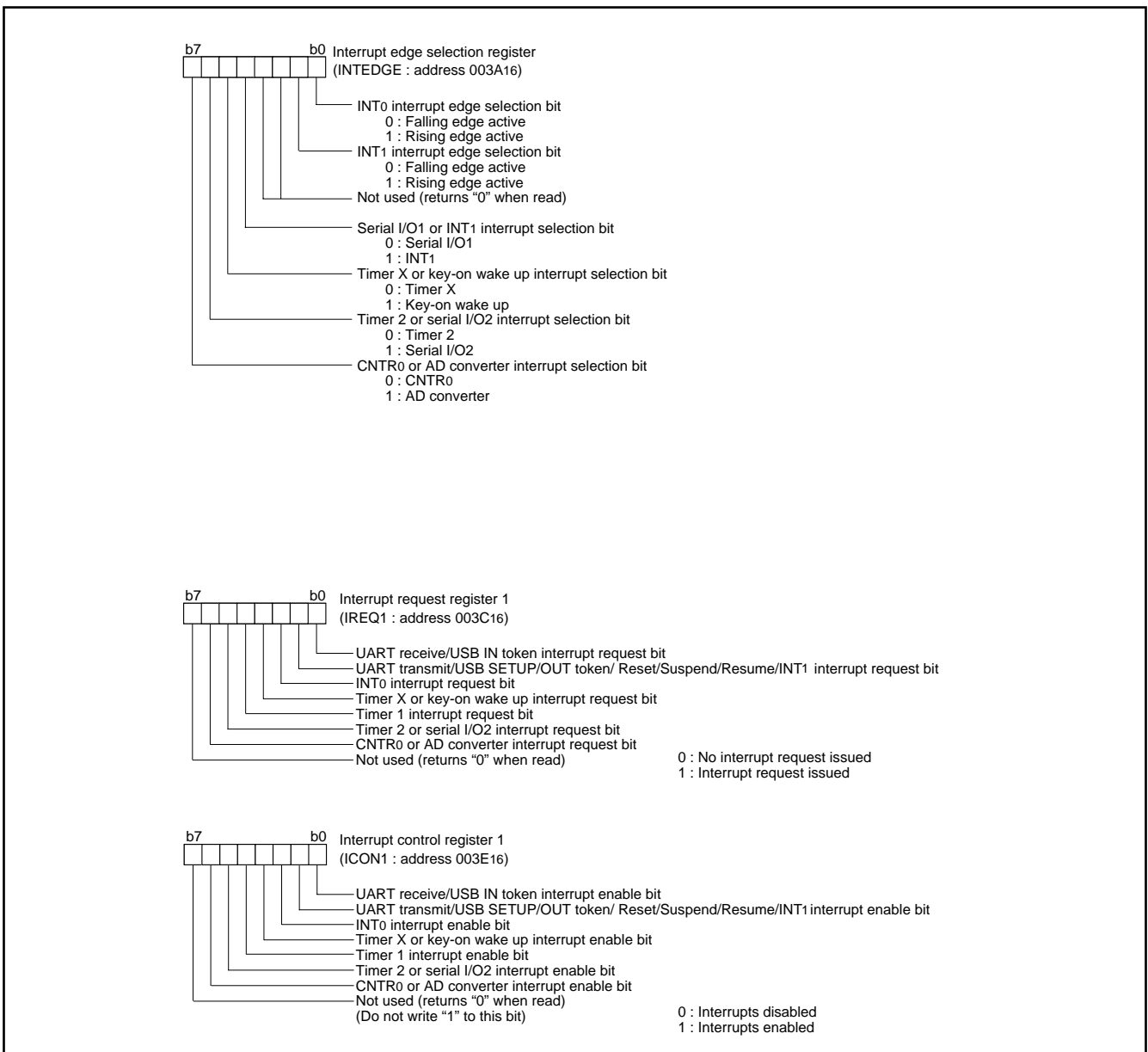

Fig. 14 Structure of interrupt-related registers

### Key Input Interrupt (Key-On Wake-Up)

A key-on wake-up interrupt request is generated by applying "L" level to any pin of port P0 that has been set to input mode.

In other words, it is generated when the AND of input level goes from "1" to "0". An example of using a key input interrupt is shown in Figure 15, where an interrupt request is generated by pressing one of the keys provided as an active-low key matrix which uses ports P00 to P03 as input ports.

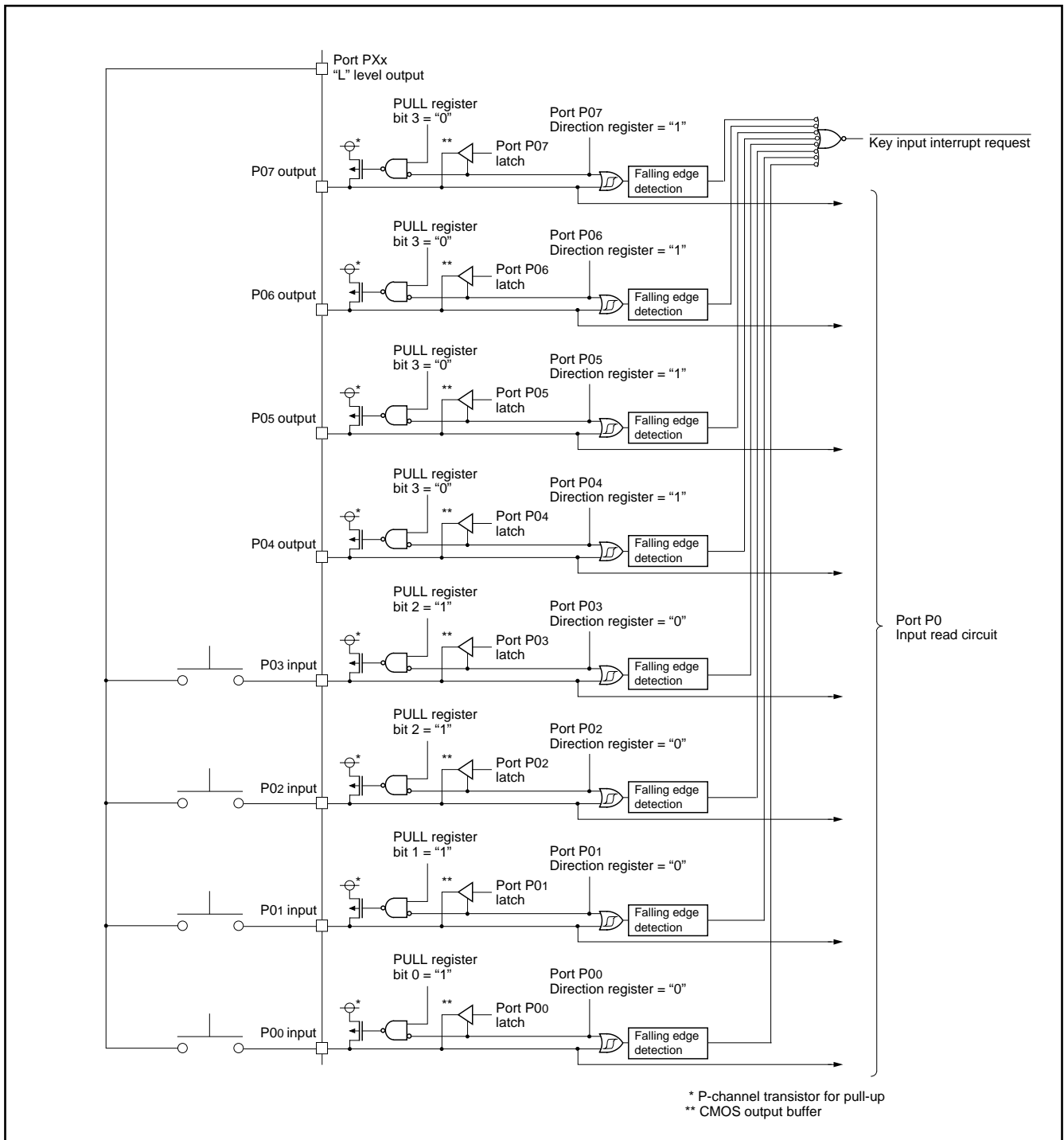

Fig. 15 Connection example when using key input interrupt and port P0 block diagram

**Timers**

The 7536 Group has 3 timers: timer X, timer 1 and timer 2. The division ratio of every timer and prescaler is  $1/(n+1)$  provided that the value of the timer latch or prescaler is n.

All the timers are down count timers. When a timer reaches "0", an underflow occurs at the next count pulse, and the corresponding timer latch is reloaded into the timer. When a timer underflows, the interrupt request bit corresponding to each timer is set to "1".

**●Timer 1, Timer 2**

Prescaler 12 always counts  $f(X_{IN})/16$ . Timer 1 and timer 2 always count the prescaler output and periodically sets the interrupt request bit.

**●Timer X**

Timer X can be selected in one of 4 operating modes by setting the timer X mode register.

**• Timer Mode**

The timer counts the signal selected by the timer X count source selection bit.

**• Pulse Output Mode**

The timer counts the signal selected by the timer X count source selection bit, and outputs a signal whose polarity is inverted each time the timer value reaches "0", from the CNTR<sub>0</sub> pin.

When the CNTR<sub>0</sub> active edge switch bit is "0", the output of the CNTR<sub>0</sub> pin is started with an "H" output.

At "1", this output is started with an "L" output. When using a timer in this mode, set the port P14 direction register to output mode.

**• Event Counter Mode**

The operation in the event counter mode is the same as that in the timer mode except that the timer counts the input signal from the CNTR<sub>0</sub> pin.

When the CNTR<sub>0</sub> active edge switch bit is "0", the timer counts the rising edge of the CNTR<sub>0</sub> pin. When this bit is "1", the timer counts the falling edge of the CNTR<sub>0</sub> pin.

**• Pulse Width Measurement Mode**

When the CNTR<sub>0</sub> active edge switch bit is "0", the timer counts the signal selected by the timer X count source selection bit while the CNTR<sub>0</sub> pin is "H". When this bit is "1", the timer counts the signal while the CNTR<sub>0</sub> pin is "L".

In any mode, the timer count can be stopped by setting the timer X count stop bit to "1". Each time the timer overflows, the interrupt request bit is set.

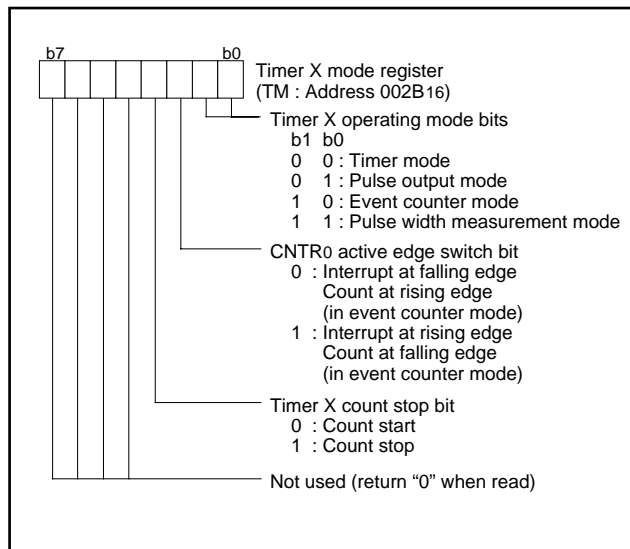

Fig. 16 Structure of timer X mode register

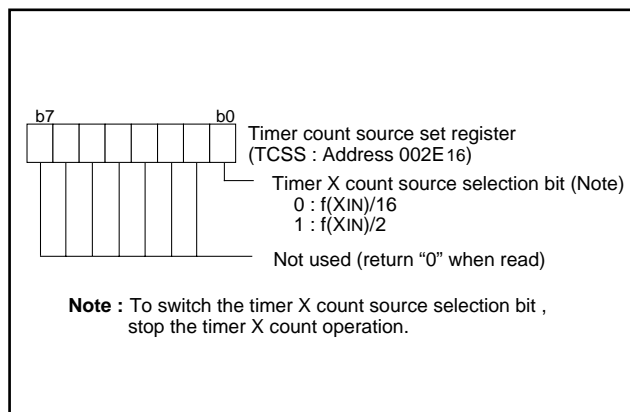

Fig. 17 Timer count source set register



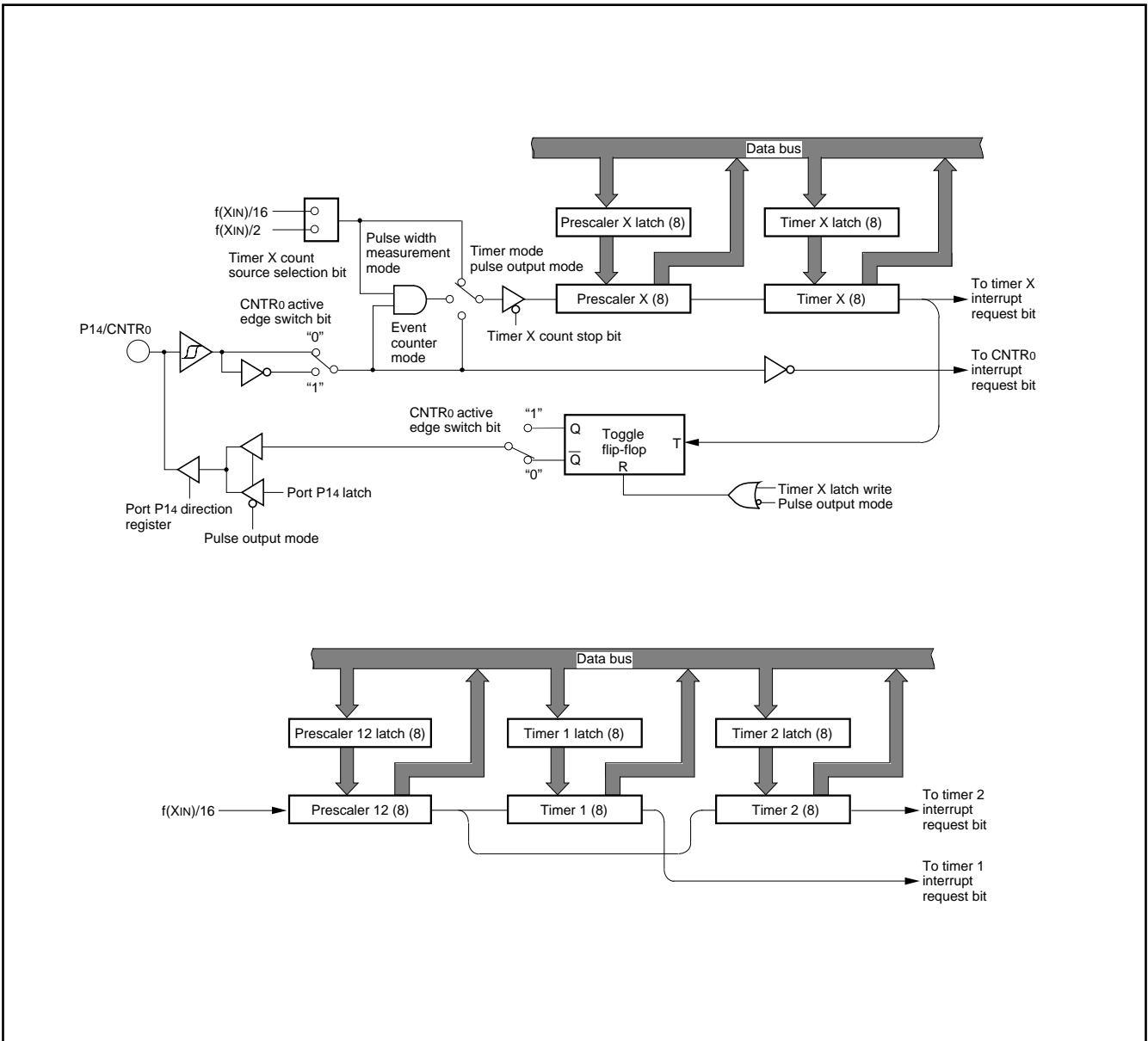

Fig. 18 Block diagram of timer X, timer 1 and timer 2

**Serial I/O**

**●Serial I/O1**

**• Asynchronous serial I/O (UART) mode**

Serial I/O1 can be used as an asynchronous (UART) serial I/O. A dedicated timer (baud rate generator) is also provided for baud rate generation when serial I/O1 is in operation.

Eight serial data transfer formats can be selected, and the transfer formats to be used by a transmitter and a receiver must be identical.

Each of the transmit and receive shift registers has a buffer register

(the same address on memory). Since the shift register cannot be written to or read from directly, transmit data is written to the transmit buffer, and receive data is read from the respective buffer registers. These buffer registers can also hold the next data to be transmitted and receive 2-byte receive data in succession.

By selecting "1" for continuous transmit valid bit (bit 2 of SIO1CON), continuous transmission of the same data is made possible. This can be used as a simplified PWM.

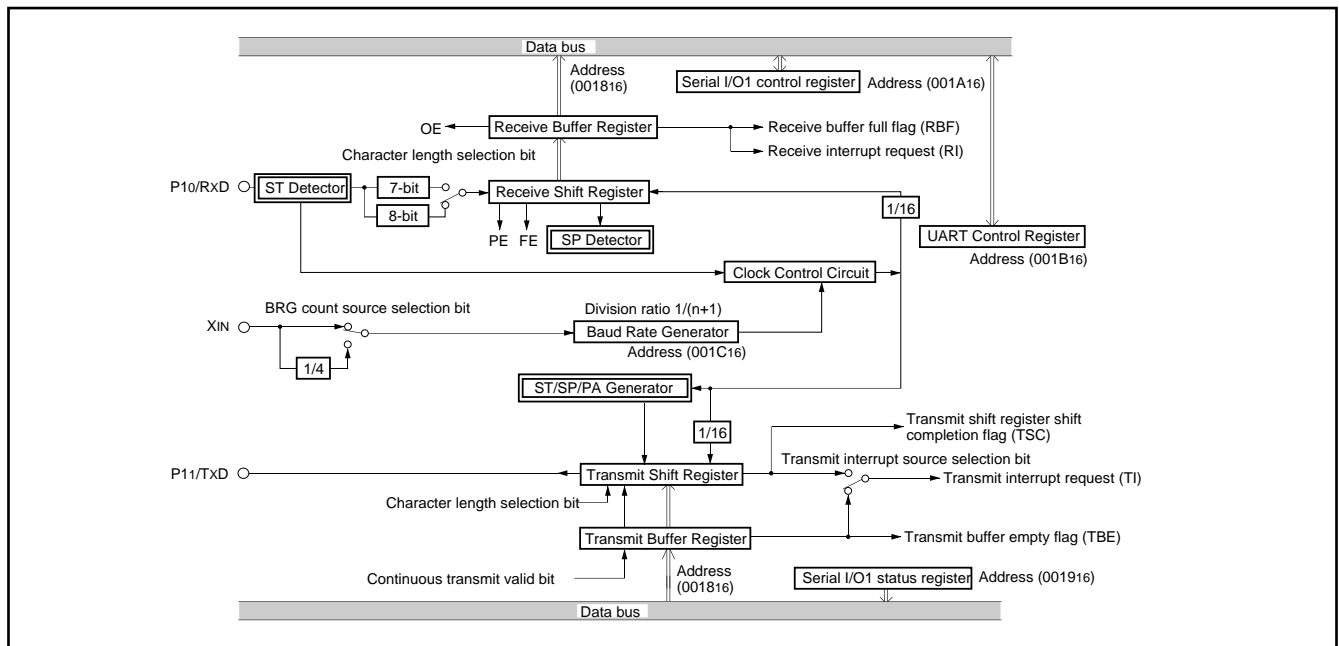

**Fig. 19 Block diagram of UART serial I/O**

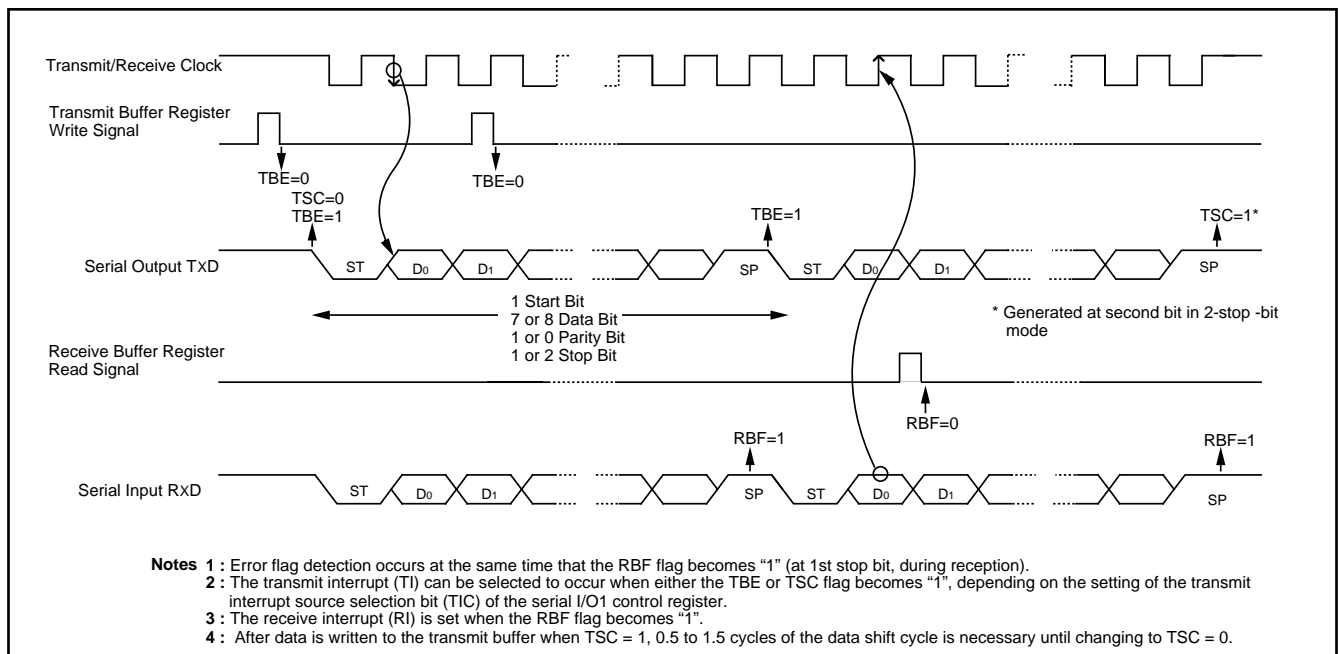

**Fig. 20 Operation of UART serial I/O function**

**[Serial I/O1 control register] SIO1CON**

The serial I/O1 control register consists of eight control bits for the serial I/O1 function.

**[UART control register] UARTCON**

The UART control register consists of four control bits (bits 0 to 3) which are valid when asynchronous serial I/O is selected and set the data format of a data transfer. One bit in this register (bit 4) is always valid and sets the input/output structure of the P11/TxD pin.

**[UART status register] UARTSTS**

The read-only UART status register consists of seven flags (bits 0 to 6) which indicate the operating status of the UART function and various errors. This register functions as the UART status register (UARTSTS) when selecting the UART.

The receive buffer full flag (bit 1) is cleared to "0" when the receive buffer is read.

If there is an error, it is detected at the same time that data is transferred from the receive shift register to the receive buffer, and the receive buffer full flag is set. A write to the serial I/O1 status register clears all the error flags OE, PE, FE, and SE (bit 3 to bit 6, respectively). Writing "0" to the serial I/O1 mode selection bits MOD1 and MOD0 (bit 7 and 6 of the Serial I/O1 control register) also clears all the status flags, including the error flags.

All bits of the serial I/O1 status register are initialized to "8116" at reset, but if the transmit enable bit (bit 4) of the serial I/O1 control register has been set to "1", the continuous transmit valid bit (bit 2) becomes "1".

**[Transmit/Receive buffer register] TB/RB**

The transmit buffer and the receive buffer are located at the same address. The transmit buffer is write-only and the receive buffer is read-only. If a character bit length is 7-bit, the MSB of data stored in the receive buffer is "0".

**[Baud Rate Generator] BRG**

The baud rate generator determines the baud rate for serial transfer. The baud rate generator divides the frequency of the count source by  $1/(n + 1)$ , where n is the value written to the baud rate generator.

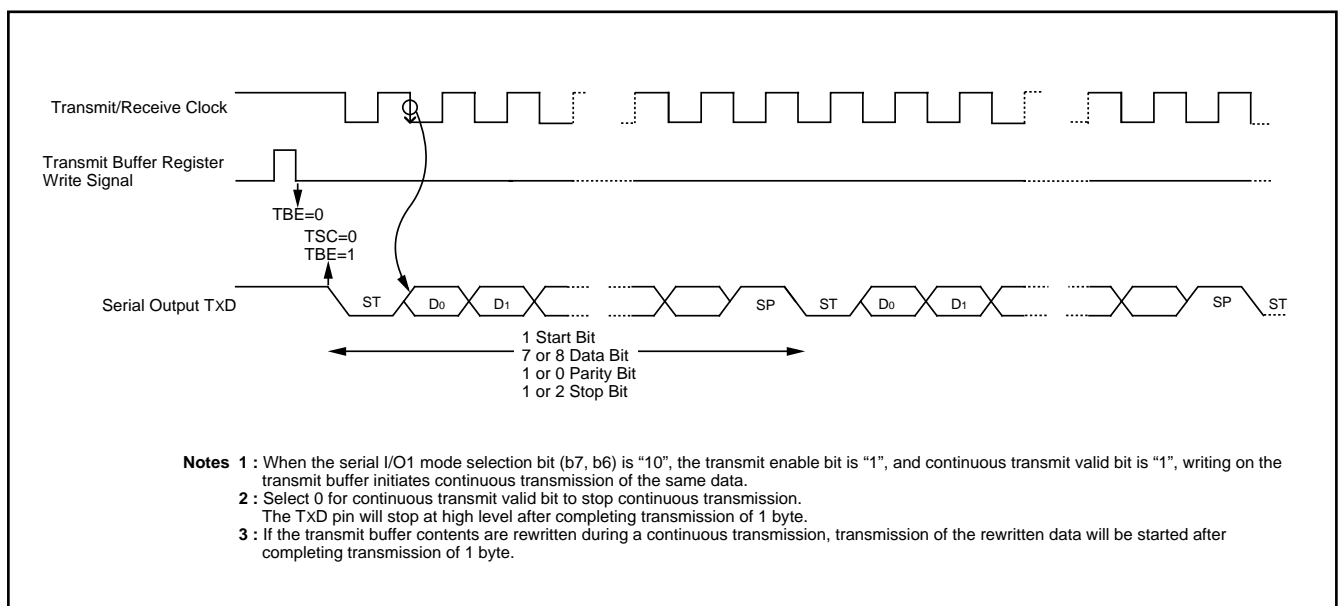

Fig. 21 Continuous transmission operation of UART serial I/O

• Universal serial bus (USB) mode

By setting bits 7 and 6 of the serial I/O1 control register (address 001A16) to "11", the USB mode is selected.

This mode conforms to "Low Speed device" of USB Specification 1.0. In this mode serial I/O1 interrupt have 6 sources; USB in and out token receive, USB reset, suspend, and resume. The USB/UART

status register (address 001916) functions as the USB status register (USBSTS). There is the USBVREFOUT pin for the USB reference voltage output, and a D-line with 1.5 kΩ external resistor can be pull up.

USB mode block and USB transceiver block show in figures 22 and 23.

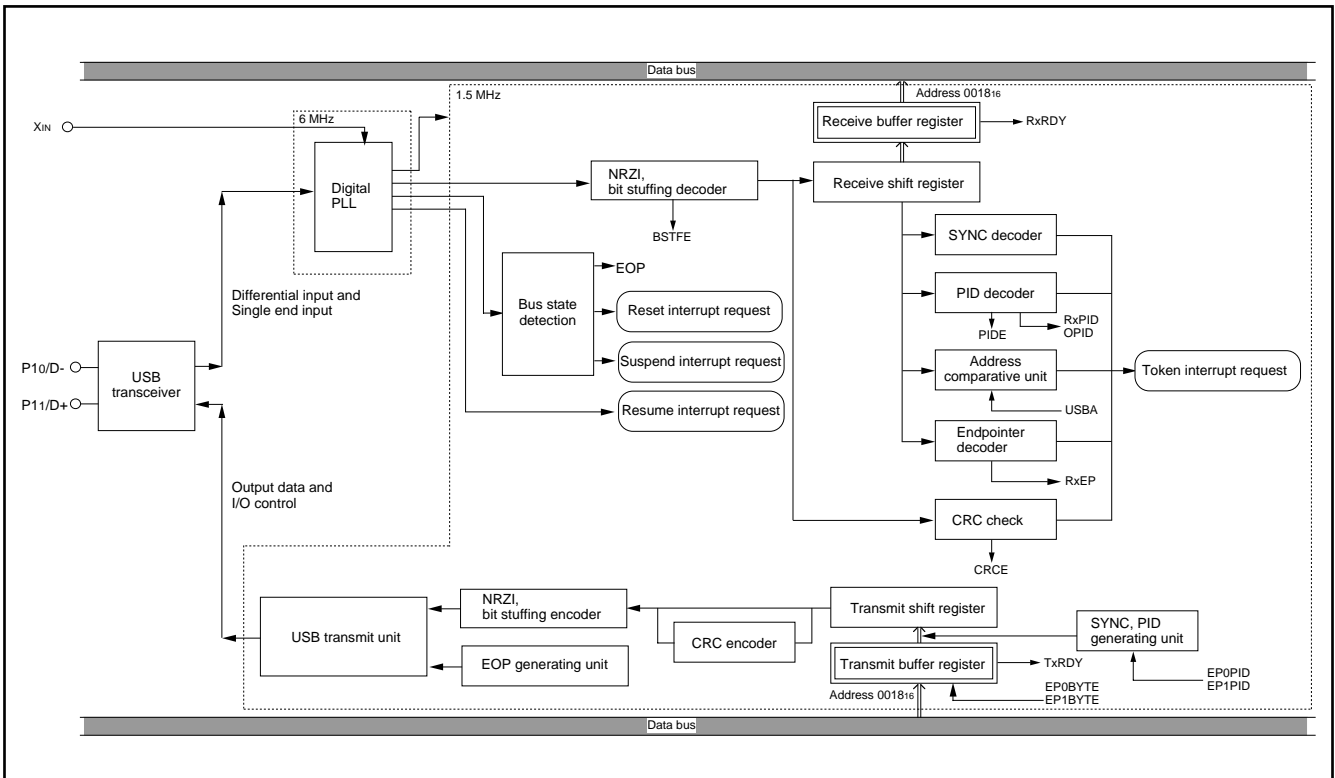

Fig. 22 USB mode block diagram

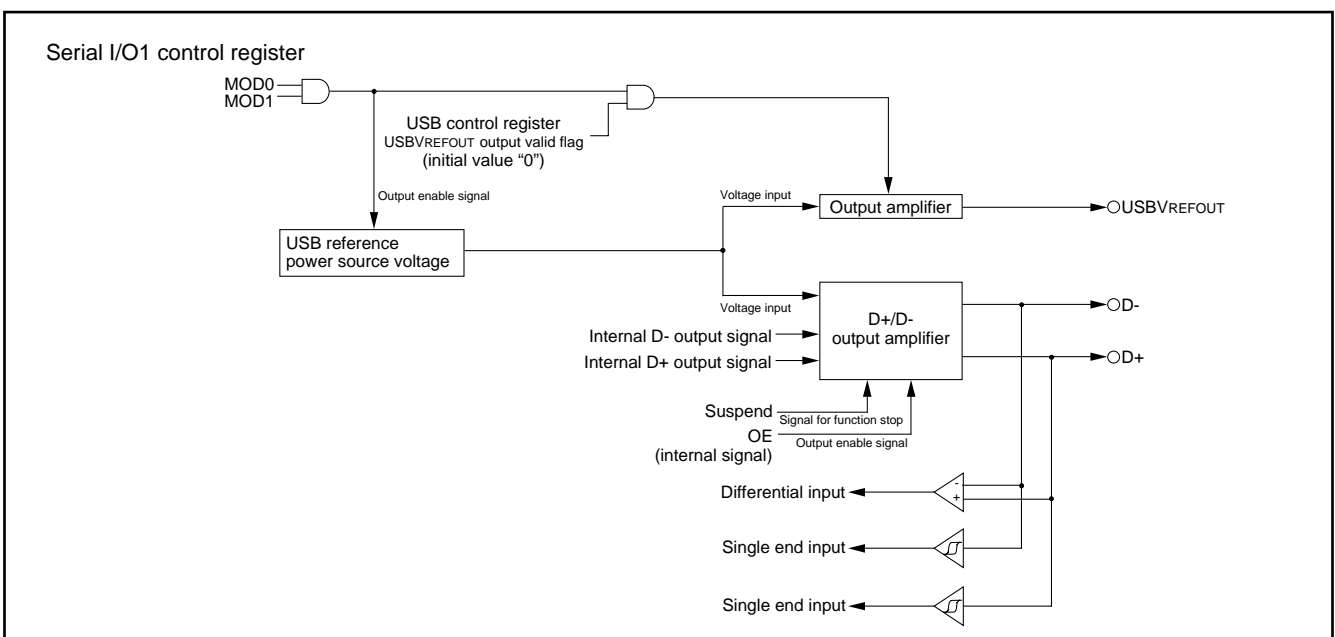

Fig. 23 USB transceiver block diagram

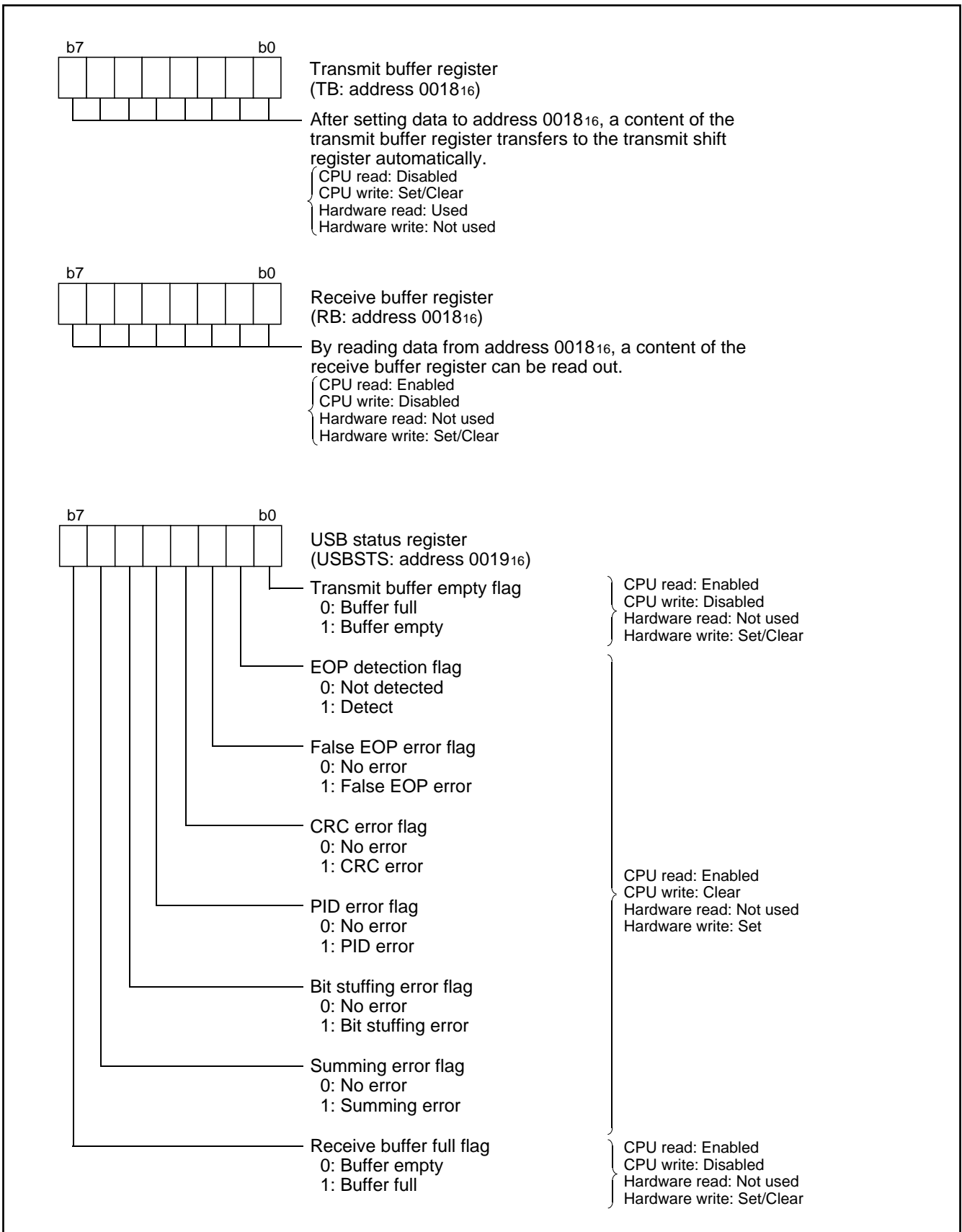

Fig. 24 Structure of serial I/O1-related registers (1)

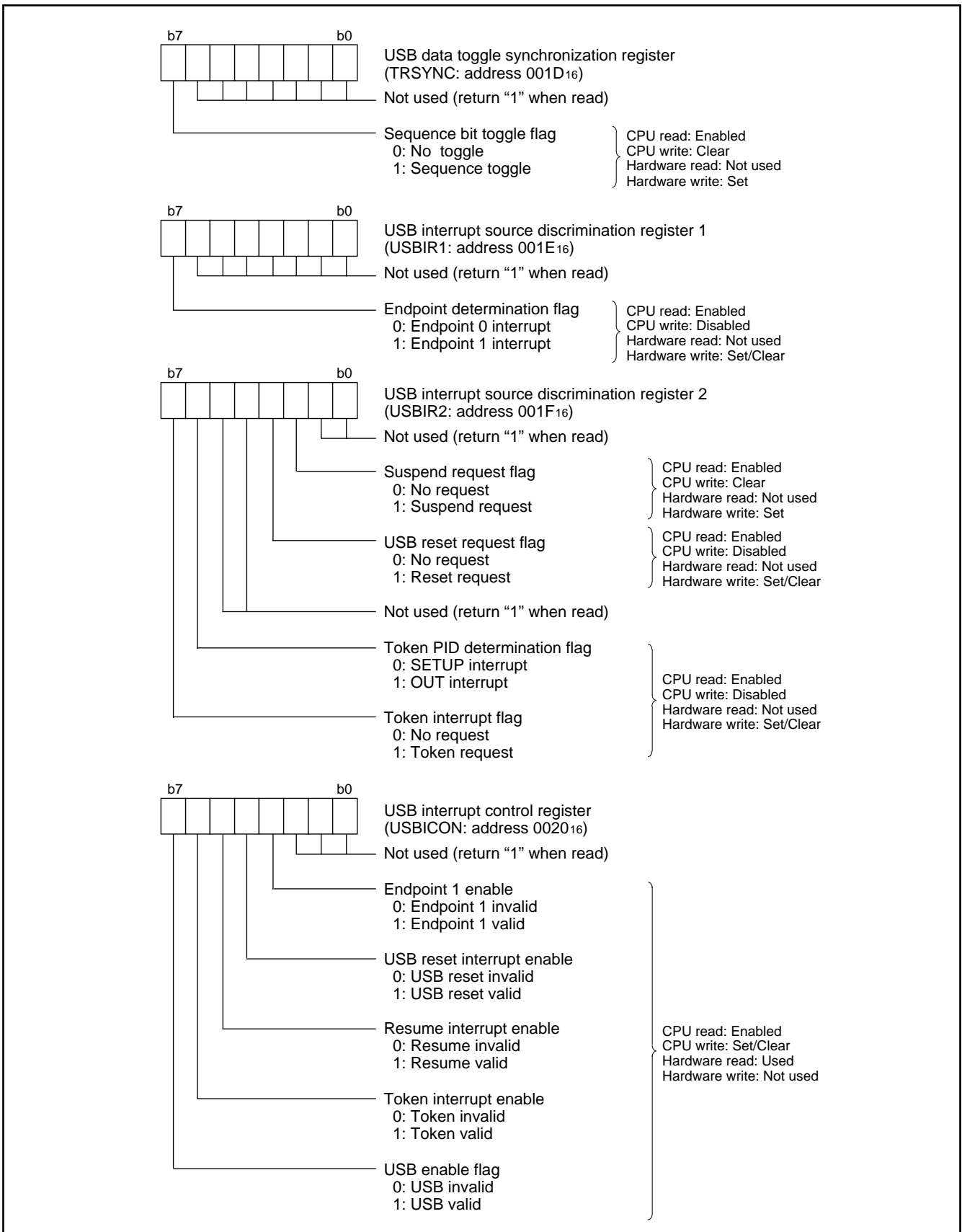

Fig. 25 Structure of serial I/O1-related registers (2)

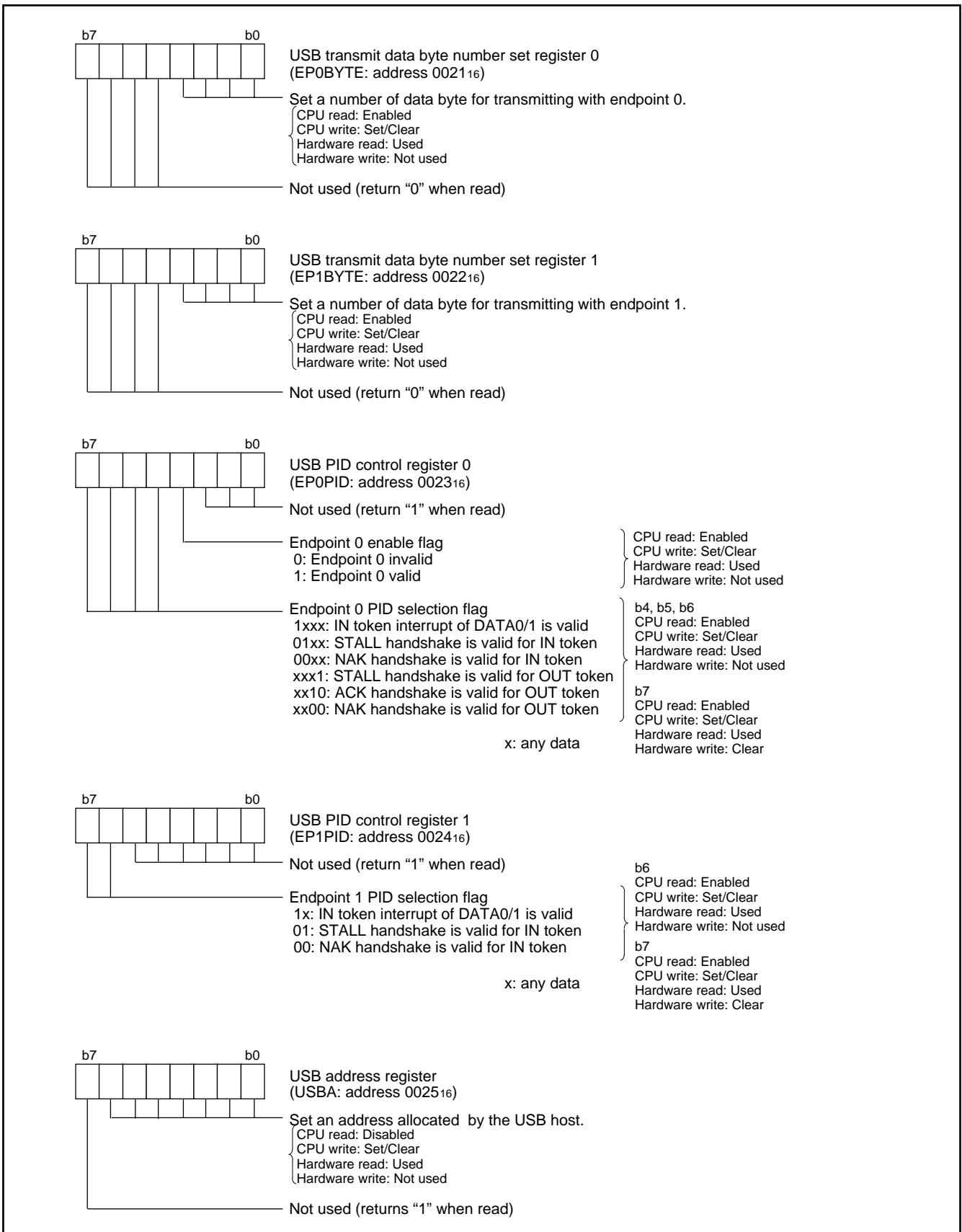

Fig. 26 Structure of serial I/O1-related registers (3)

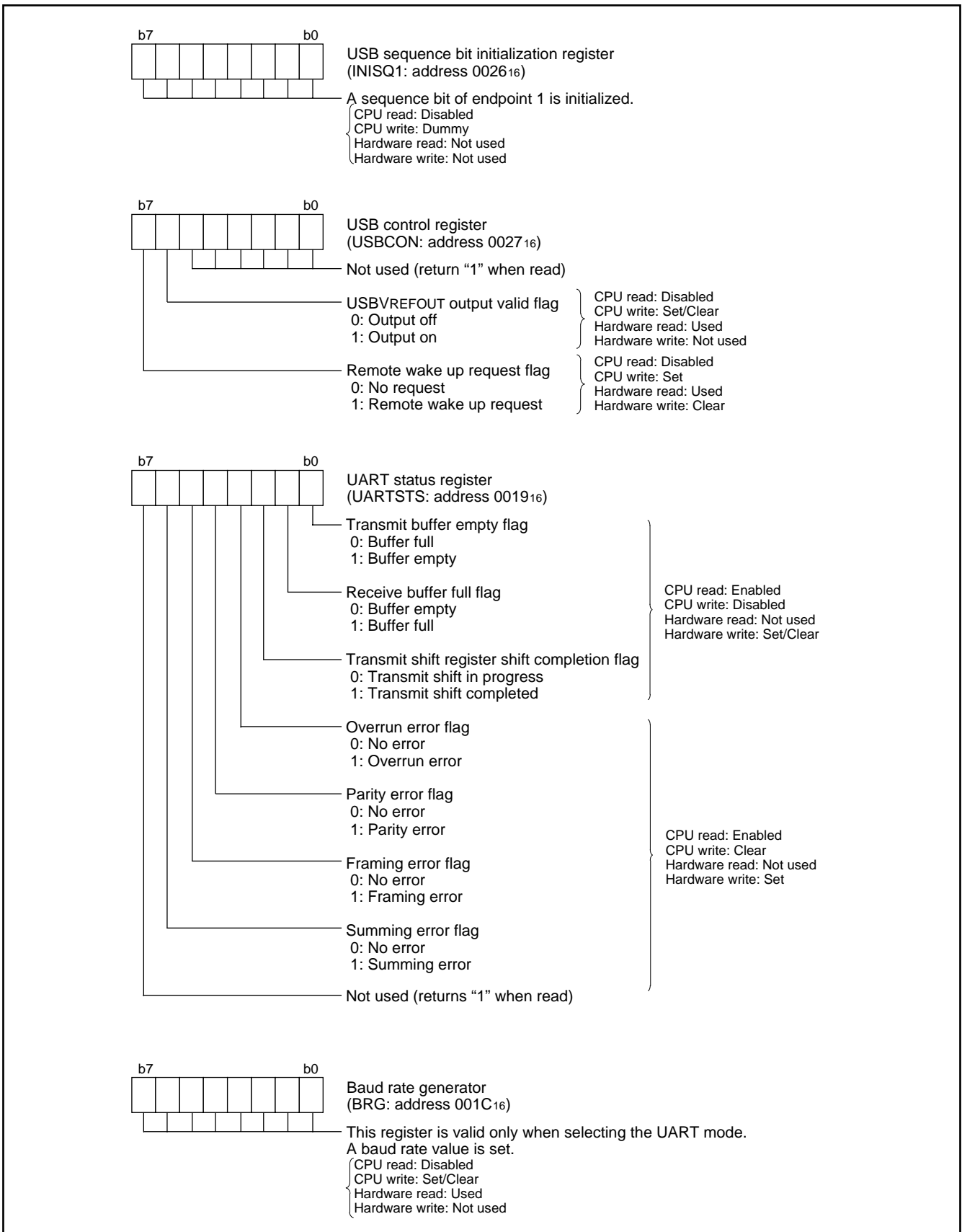

Fig. 27 Structure of serial I/O1-related registers (4)



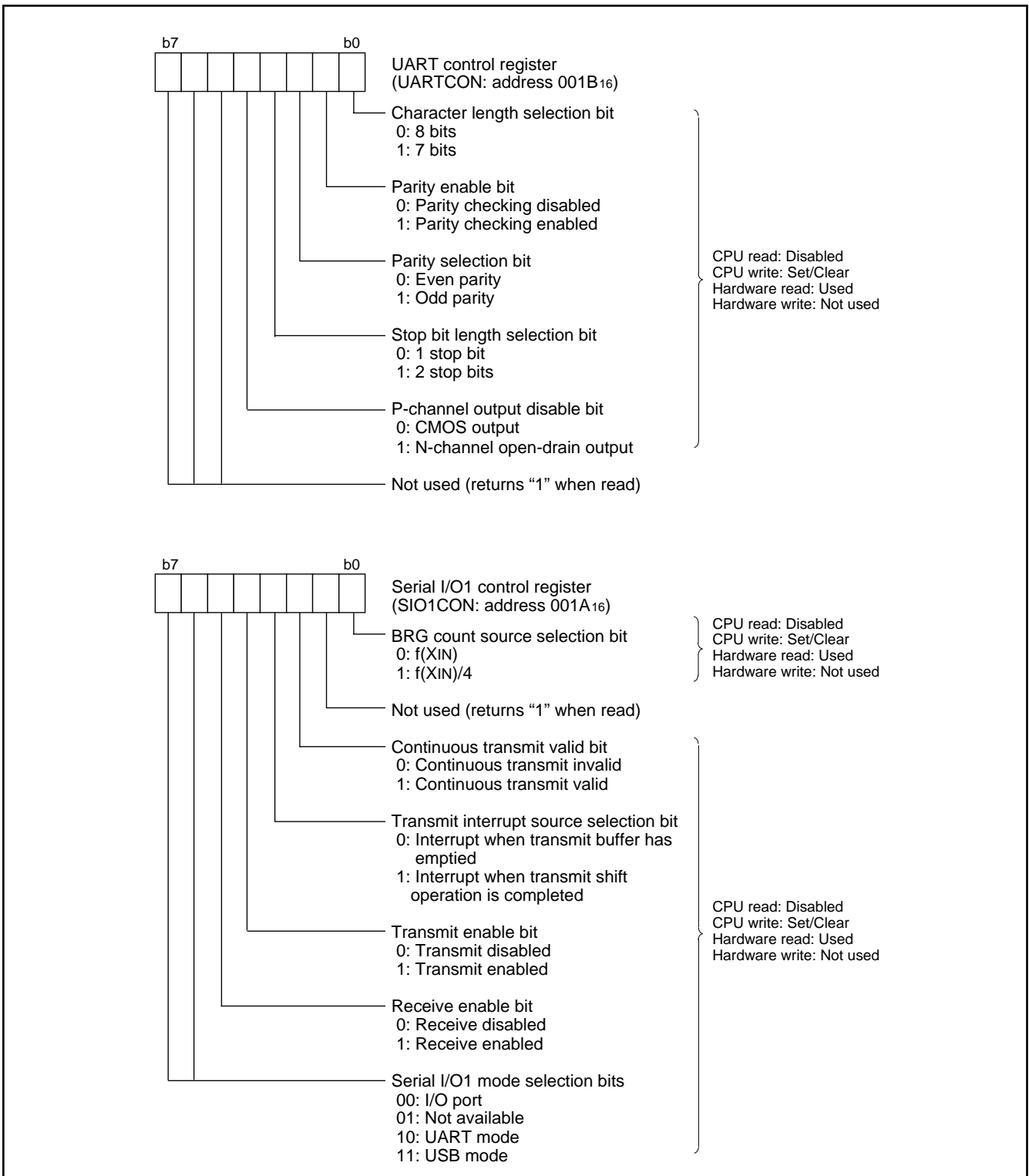

Fig. 28 Structure of serial I/O1-related registers (5)

**Note on using USB mode**

**Handling of SE0 signal in program (at receiving)**

7536 group has the border line to detect as USB RESET or EOP (End of Packet) on the width of SE0 (Single Ended 0).

A response apposite to a state of the device is expected.

The name of the following short words which is used in table 7 shows as follow.

- TKNE: Token interrupt enable (bit 6 of address 20<sub>16</sub>)
- RSME: Resume interrupt enable (bit 5 of address 20<sub>16</sub>)
- RSTE: USB reset interrupt enable (bit 4 of address 20<sub>16</sub>)
- Spec: A response of the device requested by USB Specification 1.0
- SIE: Hardware operation in 7536 group
- F/W: Recommendation process in the program
- FEOPE: False EOP error flag (bit 2 of address 19<sub>16</sub>)
- RxPID: Token interrupt flag (bit 7 of address 1F<sub>16</sub>)

**Table 5 Relation of the width of SE0 and the state of the device**

		State of device					
Width of SE0		Idle state TKNE = X RSME = 0 RSTE =1	End of Token in transaction TKNE = 1 RSME = 0 RSTE =1	End of data or handshake in transaction TKNE = 0 RSME = 0 RSTE = 0 or 1	Suspend state TKNE = 0 RSME = 1 RSTE = 0		
	0 μ sec. 0.5 μ sec.	Spec	Ignore	Ignore	Ignore	Spec	Reset or resume
SIE		Keep counting suspend timer	Not detected as EOP(in case of no detection EOP, SIE returns idle state as time out. FEOPE flag is set.)	Not detected as EOP(in case of no detection EOP, SIE returns idle state as timeup. FEOPE flag is set.)			
F/W		Not acknowledge	Not acknowledge	Wait for the next EOP flag			
0.5 μ sec. 2.5 μ sec.	Spec	Keep alive	EOP	EOP	SIE	Reset interrupt request	
	SIE	Initialize suspend timer count value	Token interrupt request	Set EOP flag			
	F/W	Not acknowledge	Token interrupt processing execute	After checking the set of EOP flag, go to the next processing			
2.5 μ sec. 2.67 μ sec.	Spec	Keep alive or Reset	EOP or Reset	EOP or Reset	F/W	Reset interrupt processing Resume interrupt processing	
	SIE	may determine as keep alive and Reset interrupt	may determine as EOP and Reset interrupt	may determine as EOP and Reset interrupt			
	F/W	Keep alive in case of no interrupt request Reset processing in case of interrupt request	RxPID = 1> Token interrupt processing RxPID = 0> Reset interrupt processing	Continue the processing in case of no interrupt request Reset processing in case of interrupt request			
2.67 μ sec.	Spec	Reset	Reset	Reset	F/W	Reset interrupt processing Resume interrupt processing	
	SIE	Reset interrupt request	Reset interrupt request	Reset interrupt request			
	F/W	Reset processing	Reset processing	Reset processing			

●Serial I/O2

The serial I/O2 function can be used only for clock synchronous serial I/O.

For clock synchronous serial I/O2 the transmitter and the receiver must use the same clock. When the internal clock is used, transfer is started by a write signal to the serial I/O2 register.

[Serial I/O2 control register] SIO2CON

The serial I/O2 control register contains 8 bits which control various serial I/O functions.

- For receiving, set "0" to bit 3.
- When receiving, bit 7 is cleared by writing dummy data to serial I/O2 register after shift is completed.
- Bit 7 is set earlier a half cycle of shift clock than completion of shift operation. Accordingly, when checking shift completion by using this bit, the setting is as follows:
  - (1) check that this bit is set to "1",
  - (2) wait a half cycle of shift clock,
  - (3) read/write to serial I/O2 register.

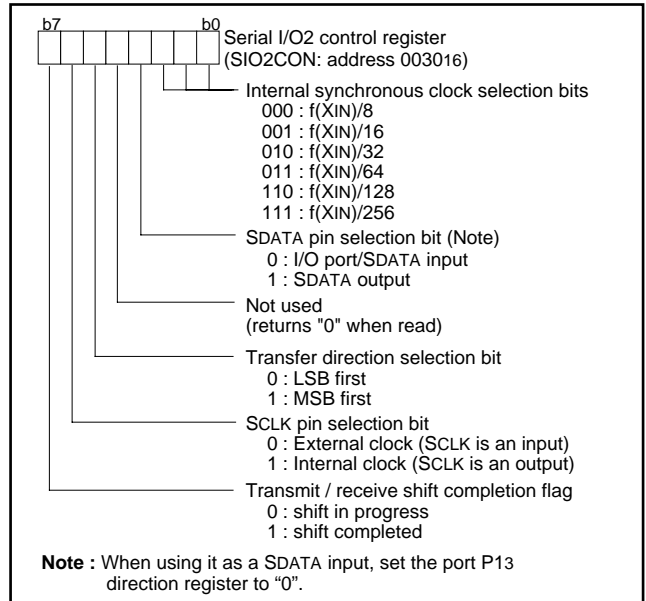

Fig. 29 Structure of serial I/O2 control registers

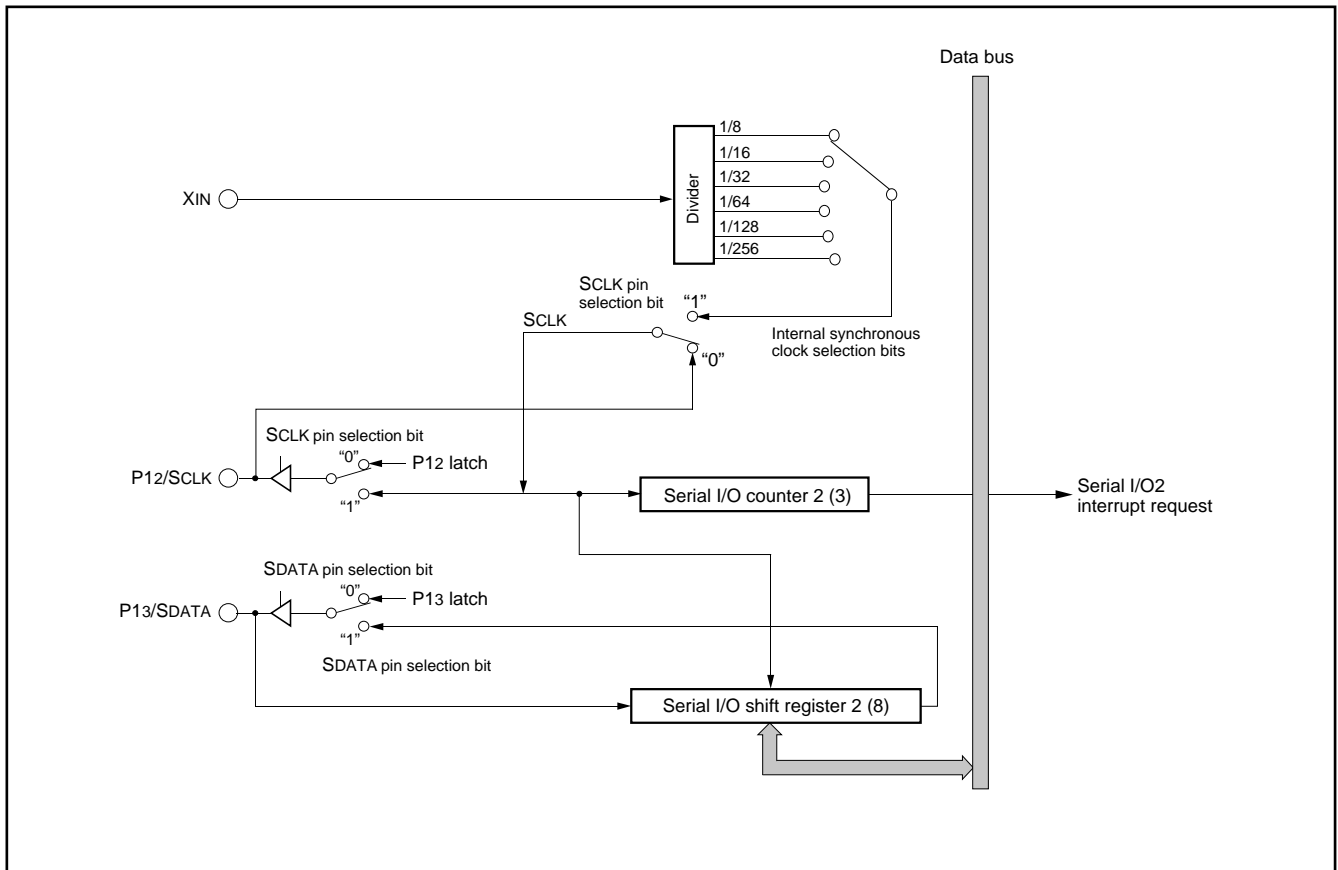

Fig. 30 Block diagram of serial I/O2

**Serial I/O2 operation**

By writing to the serial I/O2 register(address 0031<sub>16</sub>) the serial I/O2 counter is set to "7".

After writing, the SDATA pin outputs data every time the transfer clock shifts from a high to a low level. And, as the transfer clock shifts from a low to a high, the SDATA pin reads data, and at the same time the contents of the serial I/O2 register are shifted by 1 bit.

When the internal clock is selected as the transfer clock source, the following operations execute as the transfer clock counts up to 8.

- Serial I/O2 counter is cleared to "0".
- Transfer clock stops at an "H" level.
- Interrupt request bit is set.
- Shift completion flag is set.

Also, the SDATA pin is in a high impedance state after the data transfer is complete (refer to figure 31).

When the external clock is selected as the transfer clock source, the interrupt request bit is set as the transfer clock counts up to 8, but external control of the clock is required since it does not stop. Notice that the SDATA pin is not in a high impedance state on the completion of data transfer.

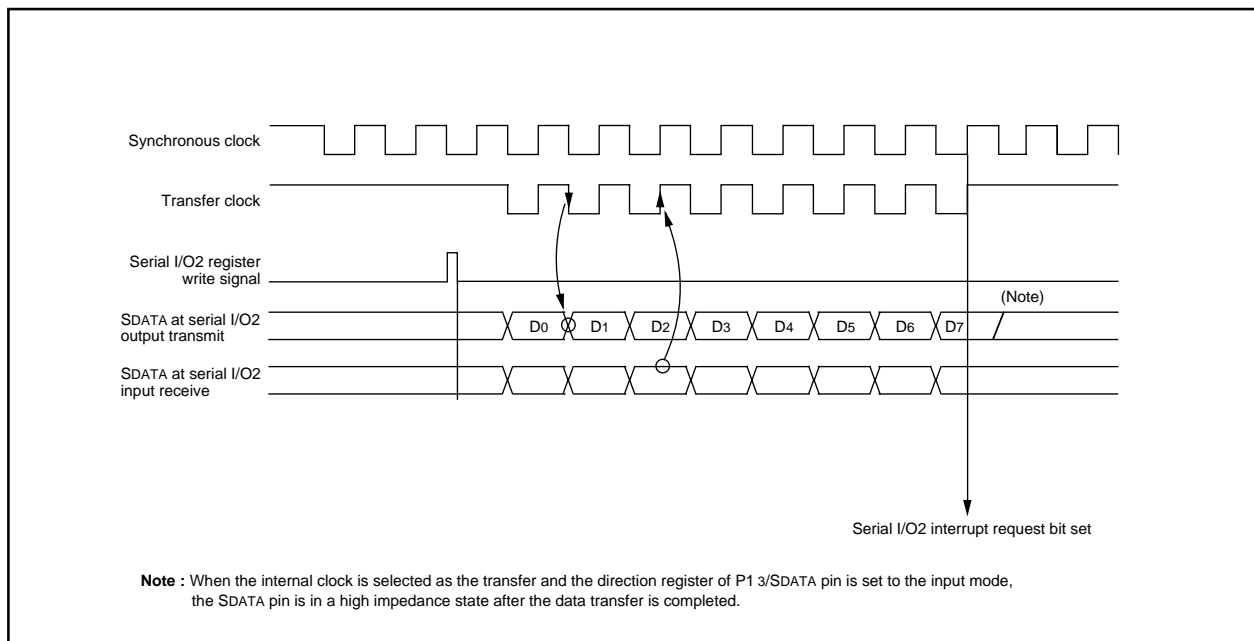

**Fig. 31 Serial I/O2 timing (LSB first)**

**A-D Converter**

The functional blocks of the A-D converter are described below.

**[A-D conversion register] AD**

The A-D conversion register is a read-only register that stores the result of A-D conversion. Do not read this register during an A-D conversion.

**[A-D control register] ADCON**

The A-D control register controls the A-D converter. Bit 2 to 0 are analog input pin selection bits. Bit 4 is the AD conversion completion bit. The value of this bit remains at "0" during A-D conversion, and changes to "1" at completion of A-D conversion. A-D conversion is started by setting this bit to "0".

**[Comparison voltage generator]**

The comparison voltage generator divides the voltage between VSS and VREF by 1024 by a resistor ladder, and outputs the divided voltages. Since the generator is disconnected from VREF pin and Vss pin, current is not flowing into the resistor ladder.

**[Channel Selector]**

The channel selector selects one of ports P27/AN7 to P20/AN0, and inputs the voltage to the comparator.

**[Comparator and control circuit]**

The comparator and control circuit compares an analog input voltage with the comparison voltage and stores its result into the A-D conversion register. When A-D conversion is completed, the control circuit sets the AD conversion completion bit and the AD interrupt request bit to "1". Because the comparator is constructed linked to a capacitor, set f(XIN) to 500 kHz or more during A-D conversion.

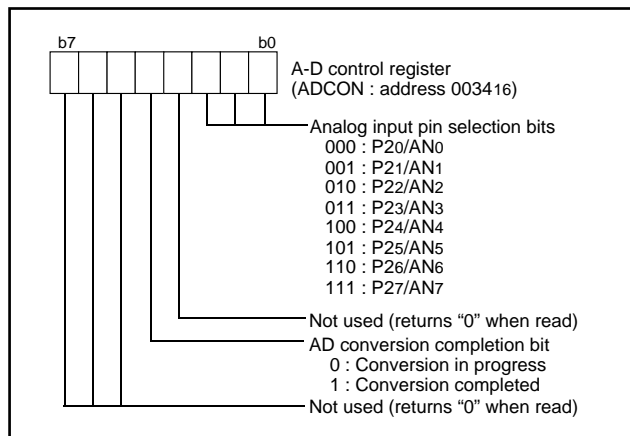

Fig. 32 Structure of A-D control register

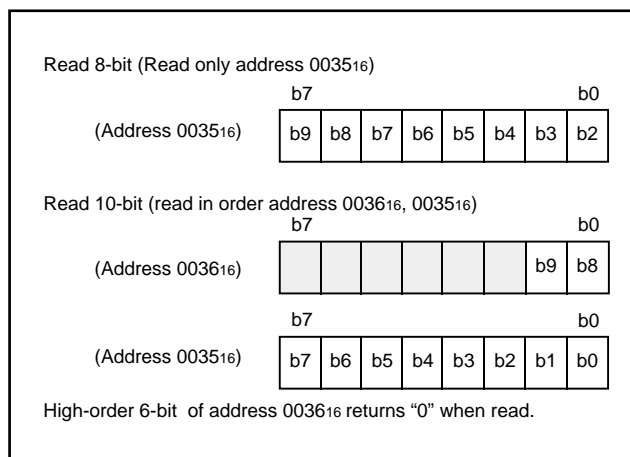

Fig. 33 Structure of A-D conversion register

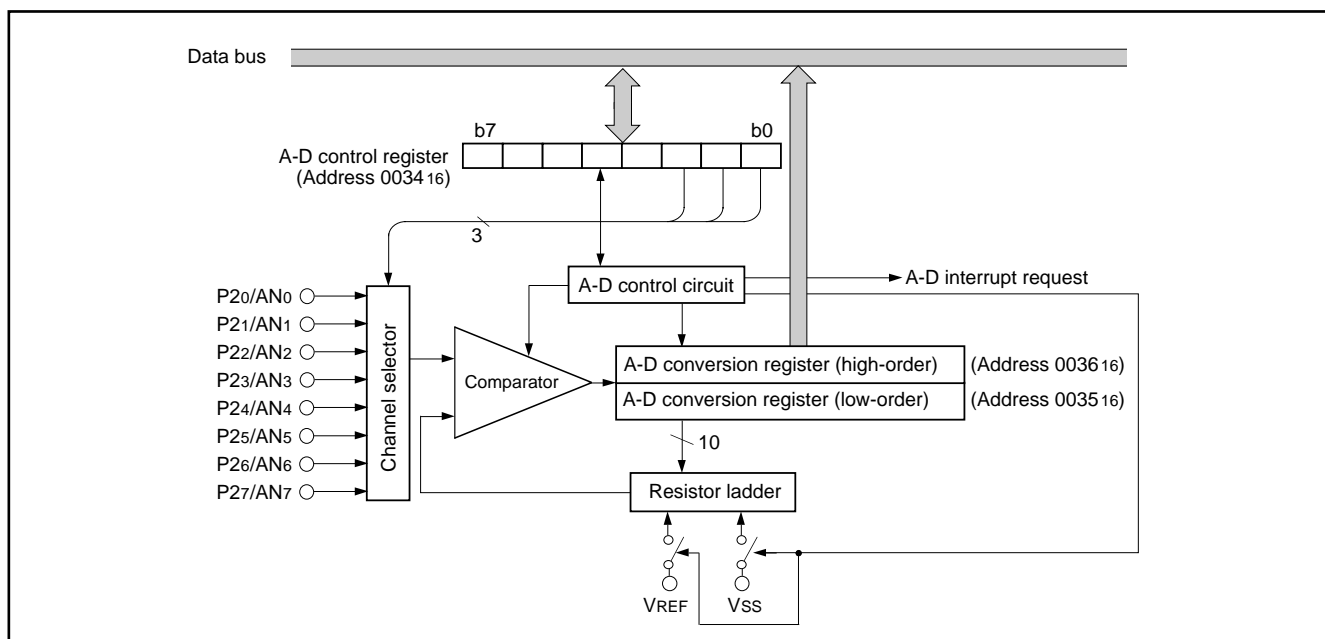

Fig. 34 Block diagram of A-D converter



**Reset Circuit**

The microcomputer is put into a reset status by holding the  $\overline{\text{RESET}}$  pin at the "L" level for 15  $\mu\text{s}$  or more when the power source voltage is 4.1 to 5.5 V and  $X_{\text{IN}}$  is in stable oscillation. After that, this reset status is released by returning the  $\overline{\text{RESET}}$  pin to the "H" level. The program starts from the address having the contents of address  $\text{FFFD}_{16}$  as high-order address and the contents of address  $\text{FFFC}_{16}$  as low-order address. Note that the reset input voltage should be 0.82 V or less when the power source voltage passes 4.1 V.

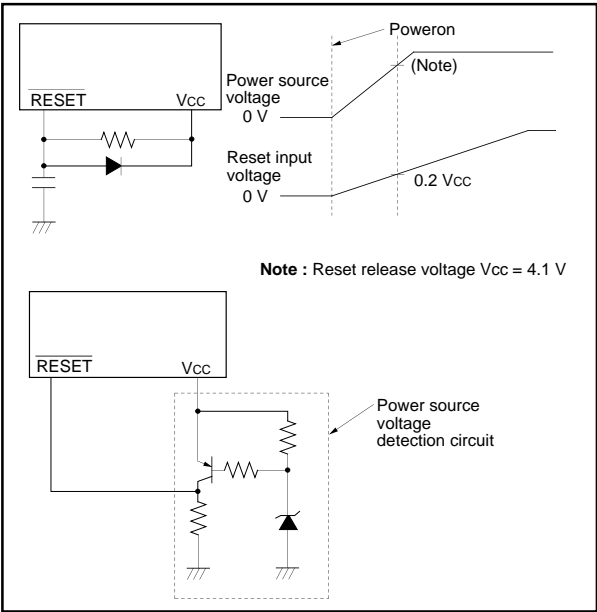

Fig. 37 Example of reset circuit

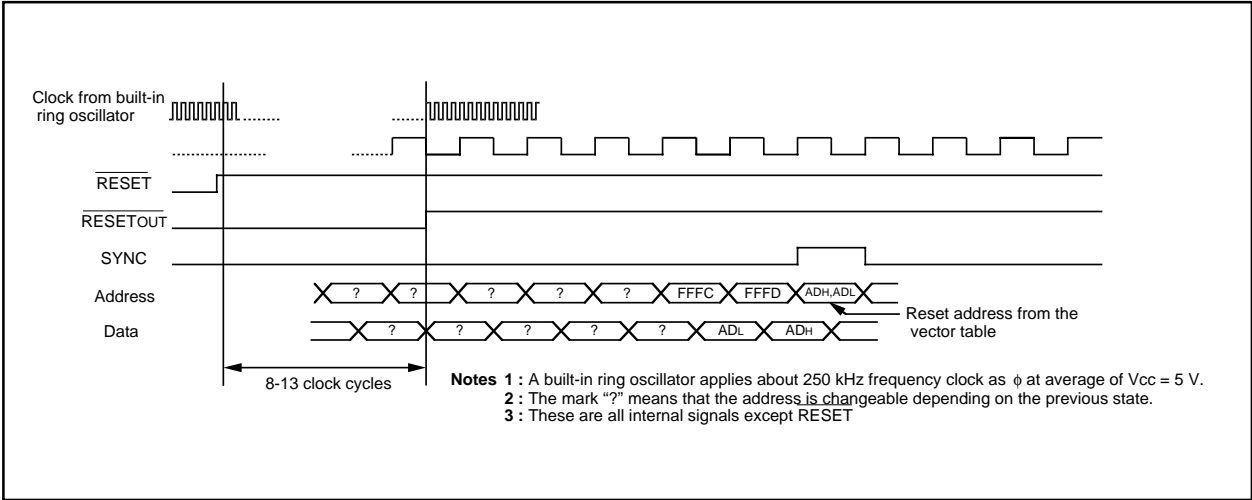

Fig. 38 Timing diagram at reset

	Address	Register contents
(1) Port P0 direction register	0001 <sub>16</sub>	00 <sub>16</sub>
(2) Port P1 direction register	0003 <sub>16</sub>	X 0 0 0 0 0 0 0
(3) Port P2 direction register	0005 <sub>16</sub>	00 <sub>16</sub>
(4) Port P3 direction register	0007 <sub>16</sub>	00 <sub>16</sub>
(5) Port P4 direction register	0009 <sub>16</sub>	X X X X X X 0 0
(6) Pull-up control register	0016 <sub>16</sub>	FF <sub>16</sub>
(7) USB/UART status register	0019 <sub>16</sub>	1 0 0 0 0 0 0 1
(8) Serial I/O1 control register	001A <sub>16</sub>	02 <sub>16</sub>
(9) UART control register	001B <sub>16</sub>	1 1 1 0 0 0 0 0
(10) USB data toggle synchronization register	001D <sub>16</sub>	0 1 1 1 1 1 1 1
(11) USB interrupt source discrimination register 1	001E <sub>16</sub>	0 1 1 1 1 1 1 1
(12) USB interrupt source discrimination register 2	001F <sub>16</sub>	0 1 1 1 0 0 1 1
(13) USB interrupt control register	0020 <sub>16</sub>	0 0 0 0 0 1 1 1
(14) USB transmit data byte number set register 0	0021 <sub>16</sub>	00 <sub>16</sub>
(15) USB transmit data byte number set register 1	0022 <sub>16</sub>	00 <sub>16</sub>
(16) USBPID control register 0	0023 <sub>16</sub>	0 0 0 0 0 1 1 1
(17) USBPID control register 1	0024 <sub>16</sub>	0 0 1 1 1 1 1 1
(18) USB address register	0025 <sub>16</sub>	1 0 0 0 0 0 0 0
(19) USB sequence bit initialization register	0026 <sub>16</sub>	1 1 1 1 1 1 1 1
(20) USB control register	0027 <sub>16</sub>	0 0 1 1 1 1 1 1
(21) Prescaler 12	0028 <sub>16</sub>	FF <sub>16</sub>
(22) Timer 1	0029 <sub>16</sub>	01 <sub>16</sub>
(23) Timer 2	002A <sub>16</sub>	00 <sub>16</sub>
(24) Timer X mode register	002B <sub>16</sub>	00 <sub>16</sub>
(25) Prescaler X	002C <sub>16</sub>	FF <sub>16</sub>
(26) Timer X	002D <sub>16</sub>	FF <sub>16</sub>
(27) Timer count source set register	002E <sub>16</sub>	00 <sub>16</sub>
(28) Serial I/O2 control register	0030 <sub>16</sub>	00 <sub>16</sub>
(29) A-D control register	0034 <sub>16</sub>	10 <sub>16</sub>
(30) MISRG	0038 <sub>16</sub>	00 <sub>16</sub>
(31) Watchdog timer control register	0039 <sub>16</sub>	0 0 1 1 1 1 1 1
(32) Interrupt edge selection register	003A <sub>16</sub>	00 <sub>16</sub>
(33) CPU mode register	003B <sub>16</sub>	1 0 0 0 0 0 0 0
(34) Interrupt request register 1	003C <sub>16</sub>	00 <sub>16</sub>
(35) Interrupt control register 1	003E <sub>16</sub>	00 <sub>16</sub>
(36) Processor status register	(PS)	X X X X X 1 X X
(37) Program counter	(PCH)	Contents of address FFFD <sub>16</sub>
	(PCL)	Contents of address FFFC <sub>16</sub>

Note X : Undefined

Fig. 39 Internal status of microcomputer at reset



**Clock Generating Circuit**

An oscillation circuit can be formed by connecting a resonator between X<sub>IN</sub> and X<sub>OUT</sub>.

Use the circuit constants in accordance with the resonator manufacturer's recommended values. No external resistor is needed between X<sub>IN</sub> and X<sub>OUT</sub> since a feed-back resistor exists on-chip.

**●Oscillation control**

For the details of the state and release of stop mode and wait mode, refer to "Stop mode" and "Wait mode" of "FUNCTIONAL DESCRIPTION SUPPLEMENT".

**• Stop mode**

When the STP instruction is executed, the internal clock  $\phi$  stops at an "H" level and the X<sub>IN</sub> oscillator stops. At this time, timer 1 is set to "011<sub>16</sub>" and prescaler 12 is set to "FF1<sub>16</sub>" when the oscillation stabilization time set bit after release of the STP instruction is "0". On the other hand, timer 1 and prescaler 12 are not set when the above bit is "1". Accordingly, set the wait time fit for the oscillation stabilization time of the oscillator to be used.

$f(X_{IN})/16$  is forcibly connected to the input of prescaler 12.

When an external interrupt is accepted, oscillation is restarted but the internal clock  $\phi$  remains at "H" until timer 1 underflows. As soon as timer 1 underflows, the internal clock  $\phi$  is supplied. This is because when a ceramic oscillator is used, some time is required until a start of oscillation.

In case oscillation is restarted by reset, no wait time is generated. So apply an "L" level to the RESET pin while oscillation becomes stable.

**• Wait mode**

If the WIT instruction is executed, the internal clock  $\phi$  stops at an "H" level, but the oscillator does not stop. The internal clock  $\phi$  re starts if a reset occurs or when an interrupt is received.

Since the oscillator does not stop, normal operation can be started immediately after the clock is restarted.

To ensure that interrupts will be received to release the STP or WIT state, interrupt enable bits must be set to "1" before the STP or WIT instruction is executed.

When the STP status is released, prescaler 12 and timer 1 will start counting with the  $f(X_{IN})/16$ , so set the timer 1 interrupt enable bit to "0" before the STP instruction is executed.

**Note**

For use with the oscillation stabilization time set bit after release of the STP instruction set to "1", set values in timer 1 and prescaler 12 after fully appreciating the oscillation stabilization time of the oscillator to be used.

**• Clock mode**

Operation is started by a built-in ring oscillator after releasing reset. A division ratio (1/1, 1/2, 1/8) is selected by setting bits 7 and 6 of the CPU mode register after releasing it.

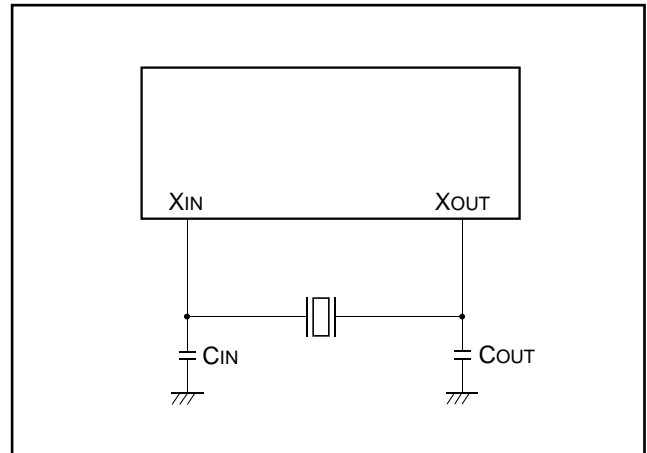

Fig. 40 External circuit of ceramic resonator

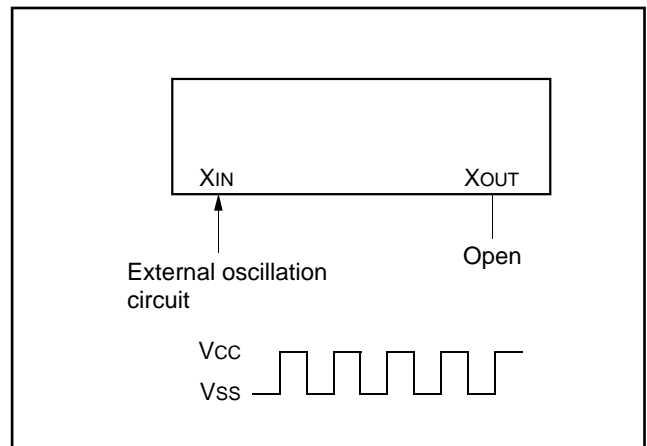

Fig. 41 External clock input circuit

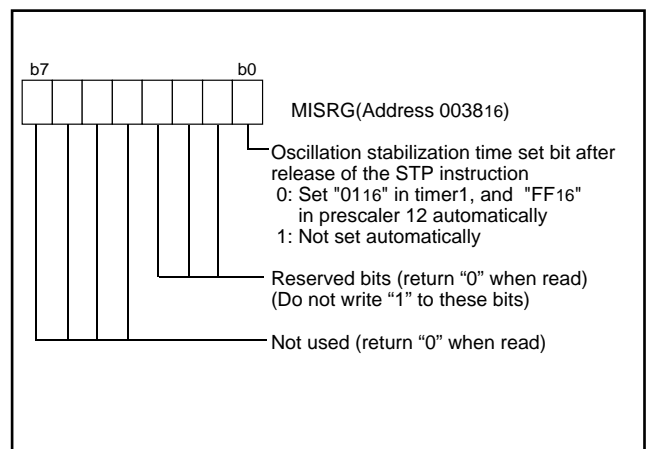

Fig. 42 Structure of MISRG

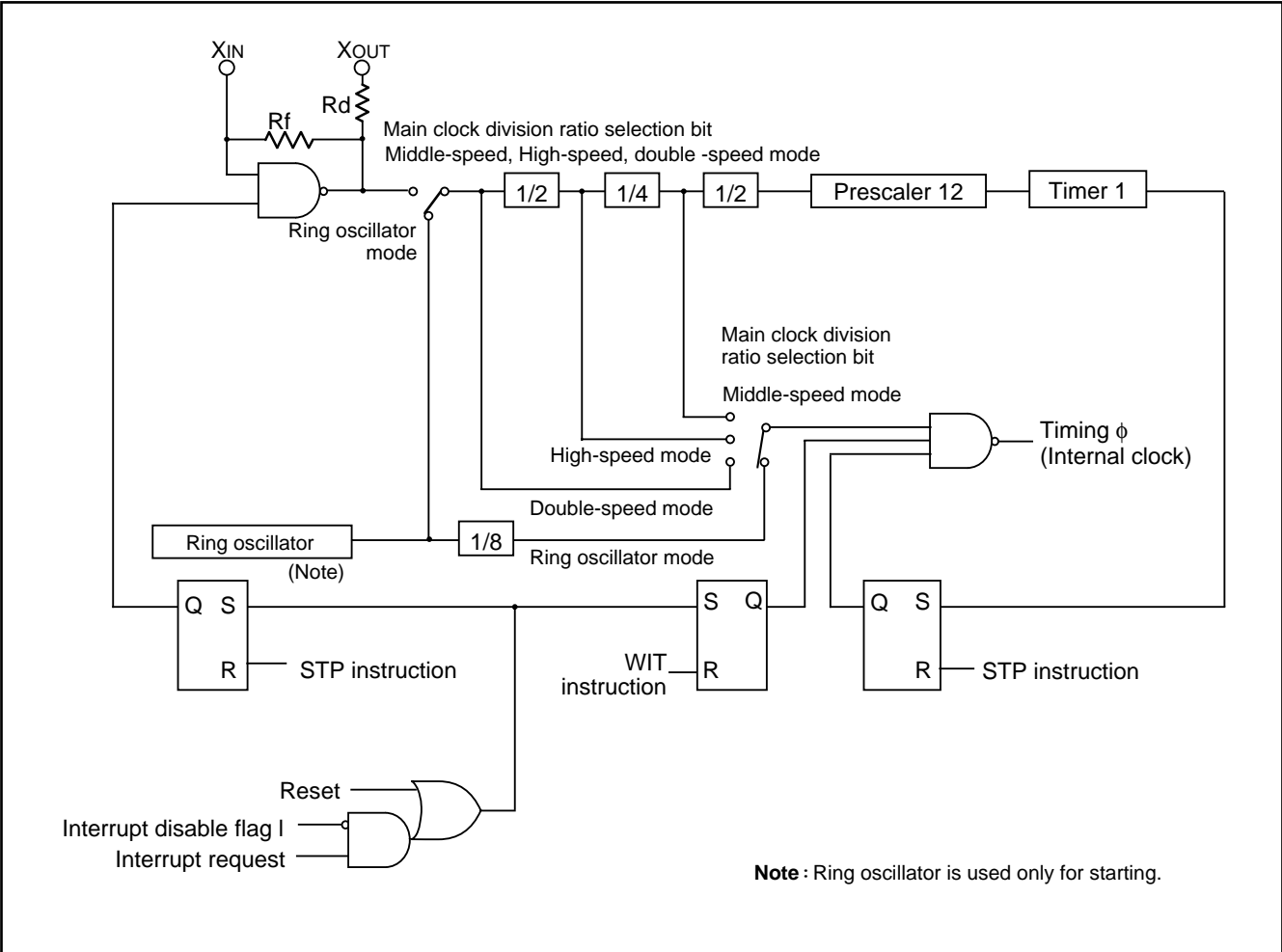

Fig. 43 Block diagram of system clock generating circuit (for ceramic resonator)

## NOTES ON PROGRAMMING

### Processor Status Register

The contents of the processor status register (PS) after reset are undefined except for the interrupt disable flag I which is "1". After reset, initialize flags which affect program execution. In particular, it is essential to initialize the T flag and the D flag because of their effect on calculations.

### Interrupts

The contents of the interrupt request bit do not change even if the BBC or BBS instruction is executed immediately after they are changed by program because this instruction is executed for the previous contents. For executing the instruction for the changed contents, execute one instruction before executing the BBC or BBS instruction.

### Decimal Calculations

- For calculations in decimal notation, set the decimal mode flag D to "1", then execute the ADC instruction or SBC instruction. In this case, execute SEC instruction, CLC instruction or CLD instruction after executing one instruction following the ADC instruction or SBC instruction.
- In the decimal mode, the values of the N (negative), V (overflow) and Z (zero) flags are invalid.

### Timers

- When n (0 to 255) is written to a timer latch, the frequency division ratio is  $1/(n+1)$ .
- When a count source of timer X is switched, stop a count of timer X.

### Ports

- The values of the port direction registers cannot be read. That is, it is impossible to use the LDA instruction, memory operation instruction when the T flag is "1", addressing mode using direction register values as qualifiers, and bit test instructions such as BBC and BBS. It is also impossible to use bit operation instructions such as CLB and SEB and read/modify/write instructions of direction registers for calculations such as ROR. For setting direction registers, use the LDM instruction, STA instruction, etc.
- Set "1" to each bit 6 of the port P3 direction register and the port P3 register (for only 7532 Group).

### A-D Converter

The comparator uses internal capacitors whose charge will be lost if the clock frequency is too low.

Make sure that  $f(X_{IN})$  is 500kHz or more during A-D conversion.

Do not execute the STP instruction during A-D conversion.

### Instruction Execution Timing

The instruction execution time can be obtained by multiplying the frequency of the internal clock  $\phi$  by the number of cycles mentioned in the machine-language instruction table.

The frequency of the internal clock  $\phi$  is the same as that of the  $X_{IN}$  in double-speed mode, twice the  $X_{IN}$  cycle in high-speed mode and 8 times the  $X_{IN}$  cycle in middle-speed mode.

## NOTES ON USE

### Handling of Power Source Pin

In order to avoid a latch-up occurrence, connect a capacitor suitable for high frequencies as bypass capacitor between power source pin ( $V_{CC}$  pin) and GND pin ( $V_{SS}$  pin). Besides, connect the capacitor to as close as possible. For bypass capacitor which should not be located too far from the pins to be connected, a ceramic capacitor of 0.1  $\mu$ F is recommended.

### Handling of USBVREFOUT Pin

In order to prevent the instability of the USBVREFOUT output due to external noise, connect a capacitor as bypass capacitor between USBVREFOUT pin and GND pin ( $V_{SS}$  pin). Besides, connect the capacitor to as close as possible. For bypass capacitor, a ceramic or electrolytic capacitor of 0.1  $\mu$ F is recommended.

### One Time PROM Version

The CNVss pin is connected to the internal memory circuit block by a low-ohmic resistance, since it has the multiplexed function to be a programmable power source pin ( $V_{PP}$  pin) as well.

To improve the noise reduction, connect a track between CNVss pin and  $V_{SS}$  pin with 1 to 10 k $\Omega$  resistance.

The mask ROM version track of CNVss pin has no operational interference even if it is connected via a resistor.

**DATA REQUIRED FOR MASK ORDERS**

The following are necessary when ordering a mask ROM production:

- (1) Mask ROM Order Confirmation Form
- (2) Mask Specification Form
- (3) Data to be written to ROM, in EPROM form  
(three identical copies)

**ROM PROGRAMMING METHOD**

The built-in PROM of the blank One Time PROM version can be read or programmed with a general-purpose PROM programmer using a special programming adapter. Set the address of PROM programmer in the user ROM area.

**Table 6 Special programming adapter**

Package	Name of Programming Adapter
42P4B	PCA7435SP

The PROM of the blank One Time PROM version is not tested or screened in the assembly process and following processes. To ensure proper operation after programming, the procedure shown in Figure 44 is recommended to verify programming.

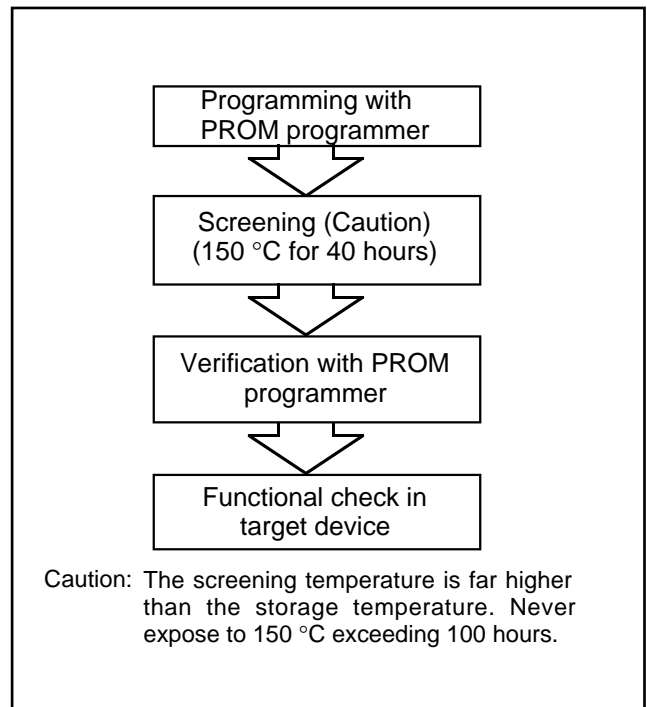

**Fig. 44 Programming and testing of One Time PROM version**

**ELECTRICAL CHARACTERISTICS**

**Table 7 Absolute maximum ratings**

Symbol	Parameter	Conditions	Ratings	Unit
VCC	Power source voltage	All voltages are based on VSS. Output transistors are cut off.	-0.3 to 7.0	V
Vi	Input voltage P00-P07, P10-P16, P20-P27, P30-P37, VREF, P40, P41		-0.3 to VCC + 0.3	V
Vi	Input voltage RESET, XIN		-0.3 to VCC + 0.3	V
Vi	Input voltage CNVSS (Note)		-0.3 to 13	V
VO	Output voltage P00-P07, P10-P16, P20-P27, P30-P37, XOUT, USBVREFOUT, P40, P41		-0.3 to VCC + 0.3	V
Pd	Power dissipation	Ta = 25°C	1000	mW
Topr	Operating temperature		-20 to 85	°C
Tstg	Storage temperature		-40 to 125	°C

**Note:** It is a rating only for the One Time PROM version. Connect to Vss for mask ROM version.

Table 8 Recommended operating conditions

(V<sub>CC</sub> = 4.1 to 5.5 V, T<sub>a</sub> = -20 to 85 °C, unless otherwise noted)

Symbol	Parameter		Limits			Unit
			Min.	Typ.	Max.	
V <sub>CC</sub>	Power source voltage	f(X <sub>IN</sub> ) = 6 MHz	4.1	5.0	5.5	V
V <sub>SS</sub>	Power source voltage			0		V
V <sub>REF</sub>	Analog reference voltage		2.0		V <sub>CC</sub>	V
V <sub>IH</sub>	"H" input voltage	P00-P07, P10-P16, P20-P27, P30-P37, P40, P41	0.8 V <sub>CC</sub>		V <sub>CC</sub>	V
V <sub>IH</sub>	"H" input voltage (TTL input level selected)	P10, P12, P13, P36, P37	2.0		V <sub>CC</sub>	V
V <sub>IH</sub>	"H" input voltage	RESET, X <sub>IN</sub>	0.8 V <sub>CC</sub>		V <sub>CC</sub>	V
V <sub>IH</sub>	"H" input voltage	D+, D-	2.0		3.6	V
V <sub>IL</sub>	"L" input voltage	P00-P07, P10-P16, P20-P27, P30-P37, P40, P41	0		0.3 V <sub>CC</sub>	V
V <sub>IL</sub>	"L" input voltage (TTL input level selected)	P10, P12, P13, P36, P37	0		0.8	V
V <sub>IL</sub>	"L" input voltage	RESET, CNV <sub>SS</sub>	0		0.2 V <sub>CC</sub>	V
V <sub>IL</sub>	"L" input voltage	D+, D-	0		0.8	V
V <sub>IL</sub>	"L" input voltage	X <sub>IN</sub>	0		0.16V <sub>CC</sub>	V
∑I <sub>OH(peak)</sub>	"H" total peak output current (Note 1)	P00-P07, P10-P16, P20-P27, P30-P37, P40, P41			-80	mA
∑I <sub>OL(peak)</sub>	"L" total peak output current (Note 1)	P00-P07, P10-P16, P20-P27, P37, P40, P41			80	mA
∑I <sub>OL(peak)</sub>	"L" total peak output current (Note 1)	P30-P36			60	mA
∑I <sub>OH(avg)</sub>	"H" total average output current (Note 1)	P00-P07, P10-P16, P20-P27, P30-P37, P40, P41			-40	mA
∑I <sub>OL(avg)</sub>	"L" total average output current (Note 1)	P00-P07, P10-P16, P20-P27, P37, P40, P41			40	mA
∑I <sub>OL(avg)</sub>	"L" total average output current (Note 1)	P30-P36			30	mA
I <sub>OH(peak)</sub>	"H" peak output current (Note 2)	P00-P07, P10-P16, P20-P27, P30-P37, P40, P41			-10	mA
I <sub>OL(peak)</sub>	"L" peak output current (Note 2)	P00-P07, P10-P16, P20-P27, P37, P40, P41			10	mA
I <sub>OL(peak)</sub>	"L" peak output current (Note 2)	P30-P36			30	mA
I <sub>OH(avg)</sub>	"H" average output current (Note 3)	P00-P07, P10-P16, P20-P27, P30-P37, P40, P41			-5	mA
I <sub>OL(avg)</sub>	"L" average output current (Note 3)	P00-P07, P10-P16, P20-P27, P37, P40, P41			5	mA
I <sub>OL(avg)</sub>	"L" average output current (Note 3)	P30-P36			15	mA
f(X <sub>IN</sub> )	Oscillation frequency (Note 4) at ceramic oscillation or external clock input	V <sub>CC</sub> = 4.1 to 5.5 V Double-speed mode			6	MHz

**Note 1:** The total output current is the sum of all the currents flowing through all the applicable ports. The total average current is an average value measured over 100 ms. The total peak current is the peak value of all the currents.

**2:** The peak output current is the peak current flowing in each port.

**3:** The average output current I<sub>OL</sub> (avg), I<sub>OH</sub> (avg) in an average value measured over 100 ms.

**4:** When the oscillation frequency has a duty cycle of 50 %.

**Table 9 Electrical characteristics (1)**  
(VCC = 4.1 to 5.5 V, VSS = 0 V, Ta = -20 to 85 °C, unless otherwise noted)

Symbol	Parameter	Test conditions	Limits			Unit
			Min.	Typ.	Max.	
VOH	"H" output voltage P00-P07, P10-P16, P20-P27, P30-P37, P40, P41 (Note 1)	IOH = -5 mA VCC = 4.1 to 5.5 V	VCC-1.5			V
		IOH = -1.0 mA VCC = 4.1 to 5.5 V	VCC-1.0			V
VOH	"H" output voltage D+, D-	VCC = 4.4 to 5.25 V Pull-down through 15kΩ ±5 % for D+, D- Pull-up through 1.5kΩ ±5 % by USBVREFOUT for D- (Ta = 0 to 70 °C)	2.8		3.6	V
VOL	"L" output voltage P00-P07, P10-P16, P20-P27, P37, P40, P41	IOL = 5 mA VCC = 4.1 to 5.5 V			1.5	V
		IOL = 1.5 mA VCC = 4.1 to 5.5 V			0.3	V
VOL	"L" output voltage D+, D-	VCC = 4.4 to 5.25 V Pull-down through 15kΩ ±5 % for D+, D- Pull-up through 1.5kΩ ±5 % by USBVREFOUT for D-(Ta = 0 to 70 °C)			0.3	V
VOL	"L" output voltage P30-P36	IOL = 15 mA VCC = 4.1 to 5.5 V			2.0	V
		IOL = 1.5 mA VCC = 4.1 to 5.5 V			0.3	V
VT+–VT–	Hysteresis D+, D-			0.15		V
VT+–VT–	Hysteresis CNTR0, INT0, INT1 (Note 2), P00-P07(Note 3)			0.4		V
VT+–VT–	Hysteresis RXD, SCLK, SDATA (Note 2)			0.5		V
VT+–VT–	Hysteresis RESET			0.5		V
IiH	"H" input current P00-P07, P10-P16, P20-P27, P30-P37, P40, P41	Vi = VCC (Pin floating. Pull-up transistors "off")			5.0	μA
IiH	"H" input current RESET	Vi = VCC			5.0	μA
IiH	"H" input current XIN	Vi = VCC		4		μA
IiL	"L" input current P00-P07, P10-P16, P20-P27, P30-P37, P40, P41	Vi = VSS (Pin floating. Pull-up transistors "off")			-5.0	μA
IiL	"L" input current RESET, CNVSS	Vi = VSS			-5.0	μA
IiL	"L" input current XIN	Vi = VSS		-4		μA
IiL	"L" input current P00-P07, P30-P37	Vi = VSS (Pull-up transistors"on")		-0.2	-0.5	mA
V <sub>RAM</sub>	RAM hold voltage	When clock stopped	2.0		5.5	V

**Note 1:** P11 is measured when the P-channel output disable bit of the UART control register (bit 4 of address 001B16) is "0".  
**2:** RXD, SCLK, SDATA, INT0 and INT1 have hystereses only when bits 0, 1 and 2 of the port P1P3 control register are set to "0" (CMOS level).  
**3:** It is available only when operating key-on wake-up.

**Table 10 Electrical characteristics (2)**  
 (VCC = 4.1 to 5.5 V, VSS = 0 V, Ta = -20 to 85 °C, unless otherwise noted)

Symbol	Parameter		Test conditions	Limits			Unit	
				Min.	Typ.	Max.		
ICC	Power source current	Double-speed mode, f(XIN) = 6 MHz, Output transistors "off"			6	10	mA	
					1.6	3.2		
					0.8			
			Increment when A-D conversion is executed f(XIN) = 6 MHz, VCC = 5 V			0.1	1.0	μA
			All oscillation stopped (in STP state) Output transistors "off"	Ta = 25 °C			10	μA
		Ta = 85 °C						
		VCC = 4.4 V to 5.25 V Oscillation stopped in USB mode USB (SUSPEND), (pull-up resistor output not included) (Fig. 45)	Ta = 0 to 70 °C			300	μA	

**Table 11 A-D Converter characteristics (1)**  
 (VCC = 4.1 to 5.5 V, VSS = 0 V, Ta = -20 to 85 °C, unless otherwise noted)

Symbol	Parameter		Test conditions	Limits			Unit
				Min.	Typ.	Max.	
—	Resolution					10	Bits
—	Linearity error		VCC = 4.1 to 5.5 V Ta = 25 °C			±3	LSB
—	Differential nonlinear error		VCC = 4.1 to 5.5 V Ta = 25 °C			±0.9	LSB
VOT	Zero transition voltage		VCC = VREF = 5.12 V	0	5	20	mV
VFST	Full scale transition voltage		VCC = VREF = 5.12 V	5105	5115	5125	mV
tCONV	Conversion time					122	tc(XIN)
RLADDER	Ladder resistor				55		kΩ
IVREF	Reference power source input current		VREF = 5.0 V	50	150	200	μA
			VREF = 3.0 V	30	70	120	
II(AD)	A-D port input current					5.0	μA

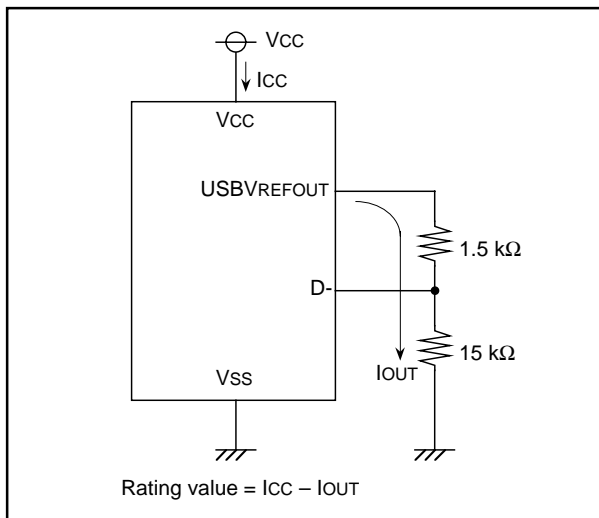

**Fig. 45 Power source current measurement circuit in USB mode at oscillation stop**



**Table 12 Timing requirements**

(VCC = 4.1 to 5.5 V, VSS = 0 V, Ta = -20 to 85 °C, unless otherwise noted)

Symbol	Parameter	Limits			Unit
		Min.	Typ.	Max.	
tw(RESET)	Reset input "L" pulse width	15			μs
tC(XIN)	External clock input cycle time	166			ns
tWH(XIN)	External clock input "H" pulse width	70			ns
tWL(XIN)	External clock input "L" pulse width	70			ns
tC(CNTR)	CNTR0 input cycle time	200			ns
tWH(CNTR)	CNTR0, INT0, INT1 input "H" pulse width	80			ns
tWL(CNTR)	CNTR0, INT0, INT1 input "L" pulse width	80			ns
tC(SCLK)	Serial I/O2 clock input cycle time	1000			ns
tWH(SCLK)	Serial I/O2 clock input "H" pulse width	400			ns
tWL(SCLK)	Serial I/O2 clock input "L" pulse width	400			ns
tsu(SCLK-SDATA)	Serial I/O2 input set up time	200			ns
th(SCLK-SDATA)	Serial I/O2 input hold time	200			ns

**Table 13 Switching characteristics**

(VCC = 4.1 to 5.5 V, VSS = 0 V, Ta = -20 to 85 °C, unless otherwise noted)

Symbol	Parameter	Limits			Unit
		Min.	Typ.	Max.	
tWH(SCLK)	Serial I/O2 clock output "H" pulse width	tC(SCLK)/2-30			ns
tWL(SCLK)	Serial I/O2 clock output "L" pulse width	tC(SCLK)/2-30			ns
td(SCLK-SDATA)	Serial I/O2 output delay time			140	ns
tv(SCLK-SDATA)	Serial I/O2 output valid time	0			ns
tr(SCLK)	Serial I/O2 clock output rising time			30	ns
tf(SCLK)	Serial I/O2 clock output falling time			30	ns
tr(CMOS)	CMOS output rising time (Note)		10	30	ns
tf(CMOS)	CMOS output falling time (Note)		10	30	ns
tr(D+), tr(D-)	USB output rising time, CL = 350 pF, Ta = 0 to 70 °C	100	200	300	ns
tr(D+), tr(D-)	USB output falling time, CL = 350 pF, Ta = 0 to 70 °C	100	200	300	ns

**Note:** XOUT pin is excluded.

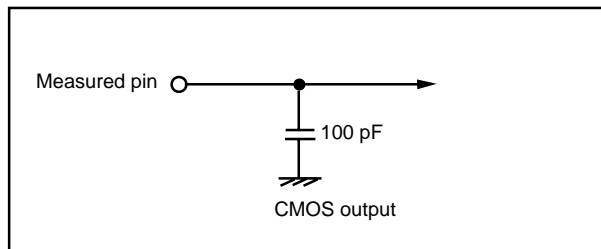

**Fig. 46 Switching characteristics measurement circuit**

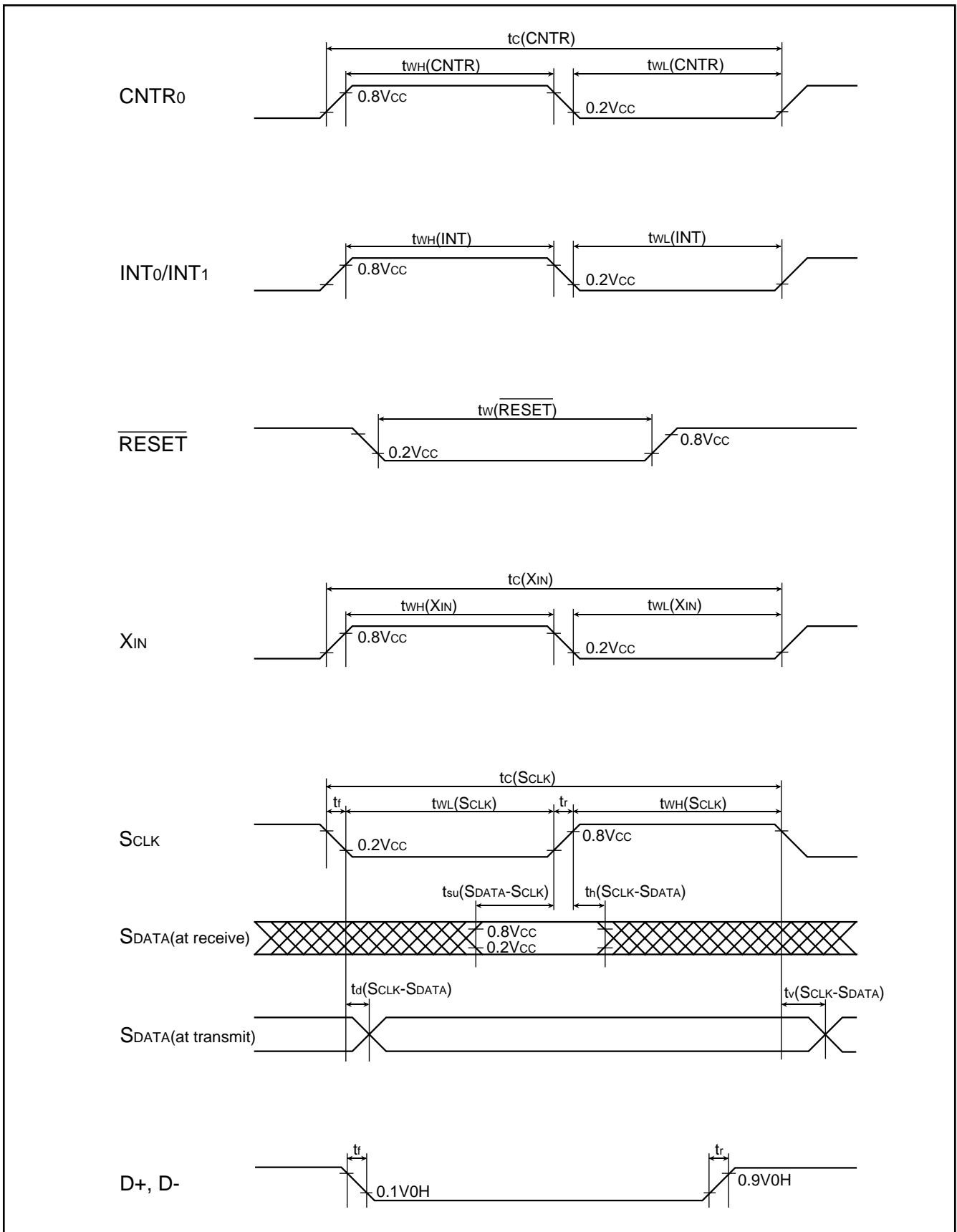

Fig. 47 Timing chart

MARK SPECIFICATION FORM

42P4B (42-PIN SHRINK DIP) MARK SPECIFICATION FORM

Mitsubishi IC catalog name

Please choose one of the marking types below (A, B, C), and enter the Mitsubishi IC catalog name and the special mark (if needed).

A. Standard Mitsubishi Mark

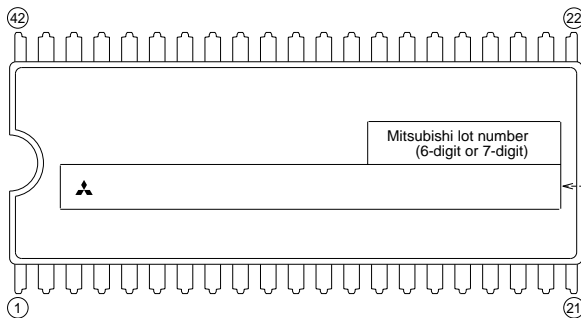

Mitsubishi IC catalog name

B. Customer's Parts Number + Mitsubishi Catalog Name

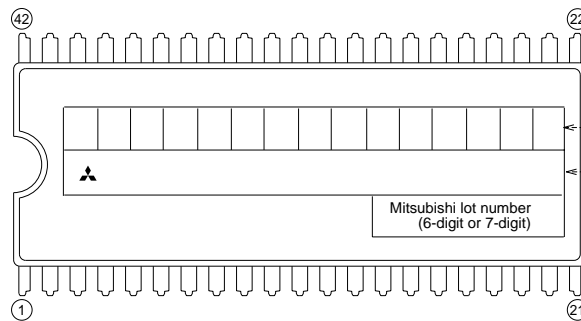

Customer's Parts Number

Note : The fonts and size of characters are standard Mitsubishi type.

Mitsubishi IC catalog name

Note1 : The mark field should be written right aligned.

2 : The fonts and size of characters are standard Mitsubishi type.

3 : Customer's Parts Number can be up to 15 characters : Only 0 ~ 9, A ~ Z, +, -, /, (, ), &, @, . (periods), , (commas) are usable.

4 : If the Mitsubishi logo is not required, check the box below.

Mitsubishi logo is not required

C. Special Mark Required

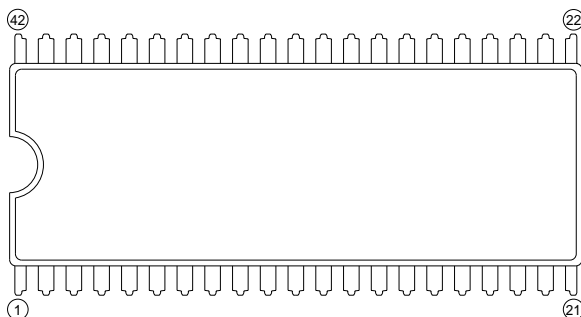

Note1 : If the Special Mark is to be Printed, indicate the desired layout of the mark in the left figure. The layout will be duplicated as close as possible.

Mitsubishi lot number (6-digit or 7-digit) and Mask ROM number (3-digit) are always marked.

2 : If the customer's trade mark logo must be used in the Special Mark, check the box below.

Please submit a clean original of the logo.

For the new special character fonts a clean font original (ideally logo drawing) must be submitted.

Special logo required

3 : The standard Mitsubishi font is used for all characters except for a logo.

PACKAGE OUTLINE

42P4B

Plastic 42pin 600mil SDIP

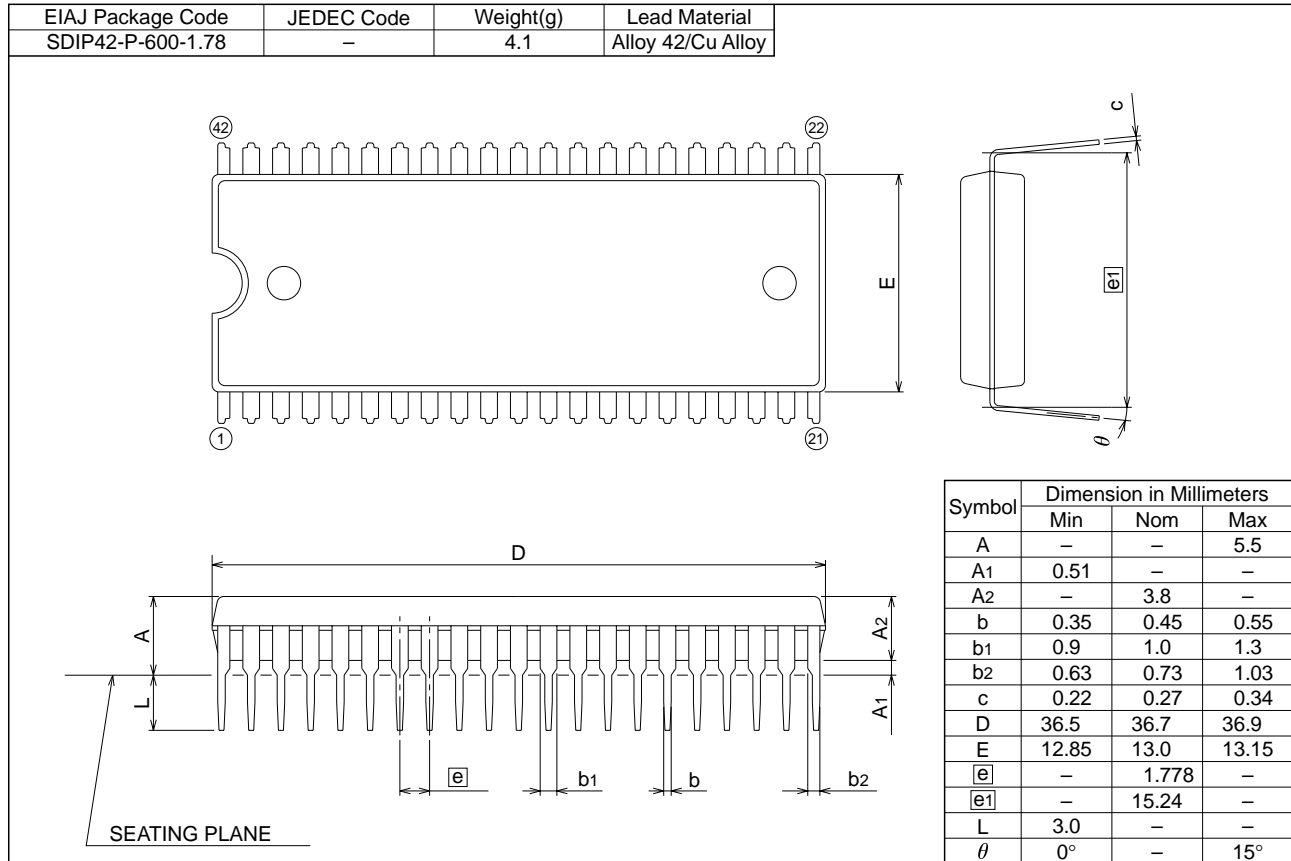

Keep safety first in your circuit designs!

- Mitsubishi Electric Corporation puts the maximum effort into making semiconductor products better and more reliable, but there is always the possibility that trouble may occur with them. Trouble with semiconductors may lead to personal injury, fire or property damage. Remember to give due consideration to safety when making your circuit designs, with appropriate measures such as (i) placement of substitutive, auxiliary circuits, (ii) use of non-flammable material or (iii) prevention against any malfunction or mishap.

Notes regarding these materials

- These materials are intended as a reference to assist our customers in the selection of the Mitsubishi semiconductor product best suited to the customer's application; they do not convey any license under any intellectual property rights, or any other rights, belonging to Mitsubishi Electric Corporation or a third party.
- Mitsubishi Electric Corporation assumes no responsibility for any damage, or infringement of any third-party's rights, originating in the use of any product data, diagrams, charts or circuit application examples contained in these materials.
- All information contained in these materials, including product data, diagrams and charts, represent information on products at the time of publication of these materials, and are subject to change by Mitsubishi Electric Corporation without notice due to product improvements or other reasons. It is therefore recommended that customers contact Mitsubishi Electric Corporation or an authorized Mitsubishi Semiconductor product distributor for the latest product information before purchasing a product listed herein.
- Mitsubishi Electric Corporation semiconductors are not designed or manufactured for use in a device or system that is used under circumstances in which human life is potentially at stake. Please contact Mitsubishi Electric Corporation or an authorized Mitsubishi Semiconductor product distributor when considering the use of a product contained herein for any specific purposes, such as apparatus or systems for transportation, vehicular, medical, aerospace, nuclear, or undersea repeater use.
- The prior written approval of Mitsubishi Electric Corporation is necessary to reprint or reproduce in whole or in part these materials.
- If these products or technologies are subject to the Japanese export control restrictions, they must be exported under a license from the Japanese government and cannot be imported into a country other than the approved destination.
- Any diversion or reexport contrary to the export control laws and regulations of Japan and/or the country of destination is prohibited.
- Please contact Mitsubishi Electric Corporation or an authorized Mitsubishi Semiconductor product distributor for further details on these materials or the products contained therein.

REVISION DESCRIPTION LIST

7536 Group DATA SHEET

Rev. No.	Revision Description	Rev. date
1.0	First Edition	980109
2.0	Most of the contents (Functional Description, Electrical characteristics, and so on) are updated.	990716
2.1	Updated as follows: Page 1; Power dissipation to 30 mW Page 7; Fig.7 Start address of Interrupt vector area to FFEC16 Page 40; Table 11; Parameter to Linearity error from former Linear error	991110
2.2	Page 11; Fig.11 Note revised Page 28; Fig.31 Note revised Page 31; Description revised; $\overline{\text{RESET}}$ "L" pulse width 2 $\mu\text{s}$ $\rightarrow$ 15 $\mu\text{s}$ Page 39; Table 9 Hysteresis " $\overline{\text{RESET}}$ " added Page 41; Table 12 $t_w(\overline{\text{RESET}})$ revised; 2 $\rightarrow$ 15	000614