

PRELIMINARY
 Notice: This is not a final specification.
 Some parametric limits are subject to change.

MITSUBISHI MICROCOMPUTERS 7540 Group

SINGLE-CHIP 8-BIT CMOS MICROCOMPUTER

DESCRIPTION

The 7540 Group is the 8-bit microcomputer based on the 740 family core technology.

The 7540 Group has a serial I/O, 8-bit timers, a 16-bit timer, and an A-D converter, and is useful for control of home electric appliances and office automation equipment.

FEATURES

- Basic machine-language instructions 71
- The minimum instruction execution time 0.50 μ s
(at 8 MHz oscillation frequency for the shortest instruction)
- Memory size ROM 16K to 32K bytes
RAM 512 to 768 bytes
- Programmable I/O ports 29
(25 in 32-pin version)
- Interrupts 15 sources, 15 vectors
(14 sources, 14 vectors for 32-pin version)
- Timers 8-bit X 4
16-bit X 1
- Serial I/O1 8-bit X 1
(UART or Clock-synchronized)
- Serial I/O2 8-bit X 1
(Clock-synchronized)
- A-D converter 10-bit X 8 channels
(6 channels for 32-pin version)
- Clock generating circuit Built-in type

(low-power dissipation by a ring oscillator enabled)

(connect to external ceramic resonator or quartz-crystal oscillator permitting RC oscillation)

- Watchdog timer 16-bit X 1
- Power source voltage
XIN oscillation frequency at ceramic oscillation, in high-speed mode
At 8 MHz 4.0 to 5.5 V
At 4 MHz 2.4 to 5.5 V
At 2 MHz 2.2 to 5.5 V
XIN oscillation frequency at RC oscillation
At 4 MHz 4.0 to 5.5 V
At 2 MHz 2.4 to 5.5 V
At 1 MHz 2.2 to 5.5 V
- Power dissipation 25 mW (standard)
- Operating temperature range -20 to 85 $^{\circ}$ C
(-40 to 85 $^{\circ}$ C for extended operating temperature version)

APPLICATION

Office automation equipment, factory automation equipment, home electric appliances, consumer electronics, car, etc.

Note: Serial I/O2 can be used in the following cases;

- (1) Serial I/O1 is not used,
- (2) Serial I/O1 is used as UART and BRG output divided by 16 is selected as the synchronized clock.

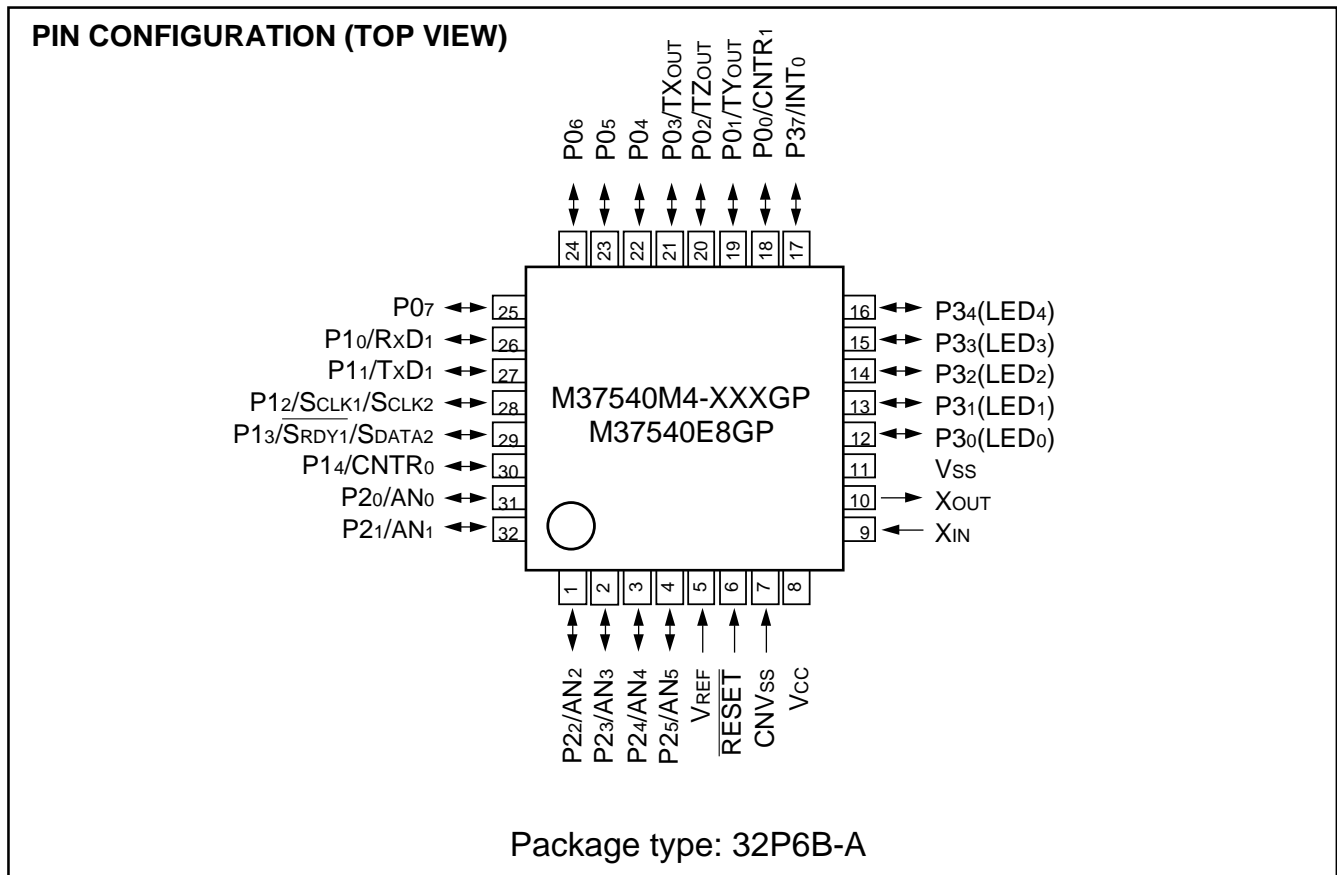

Fig. 1 M37540M4-XXXGP, M37540E8GP pin configuration

PRELIMINARY
 Notice: This is not a final specification.
 Some parametric limits are subject to change.

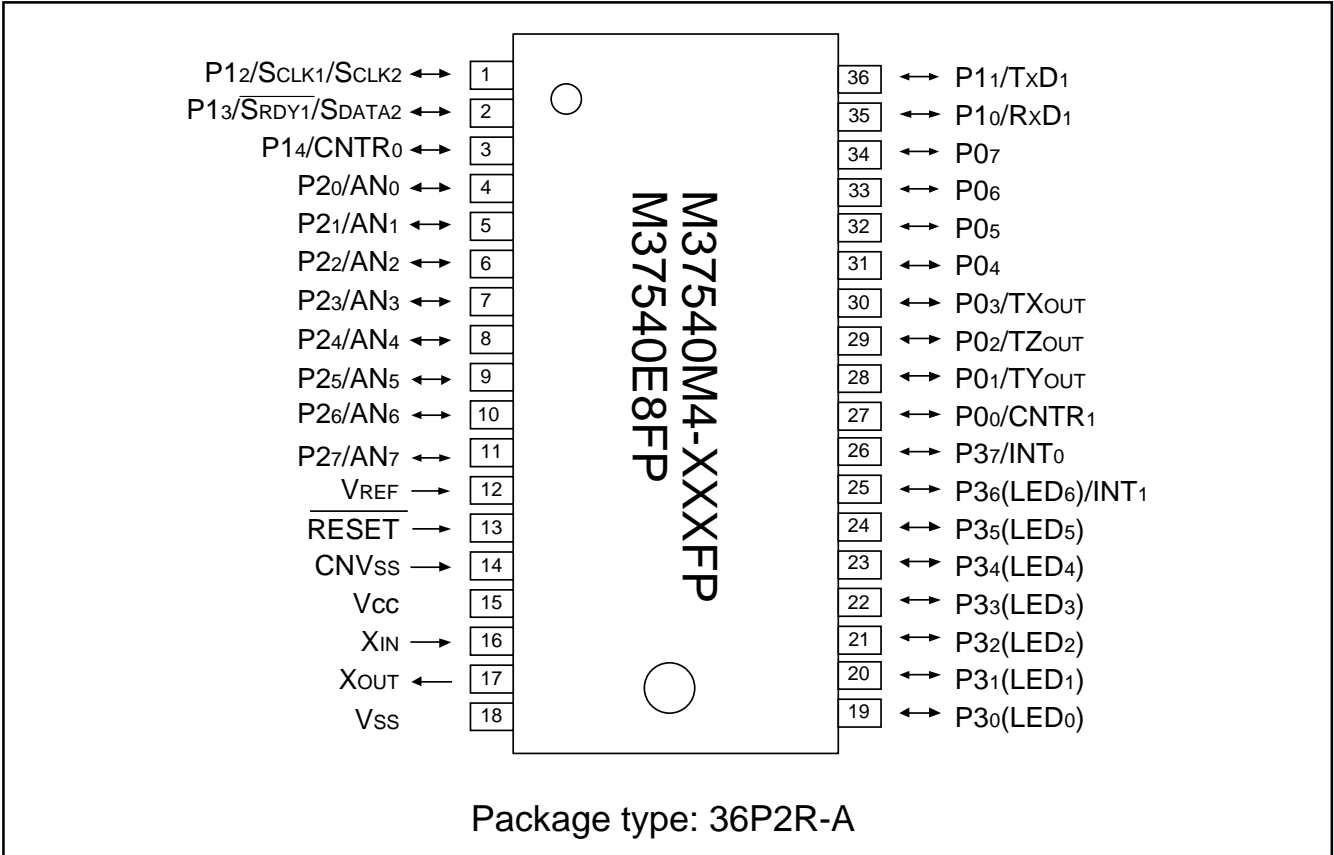

Fig. 2 M37540M4-XXXXFP, M37540E8FP pin configuration

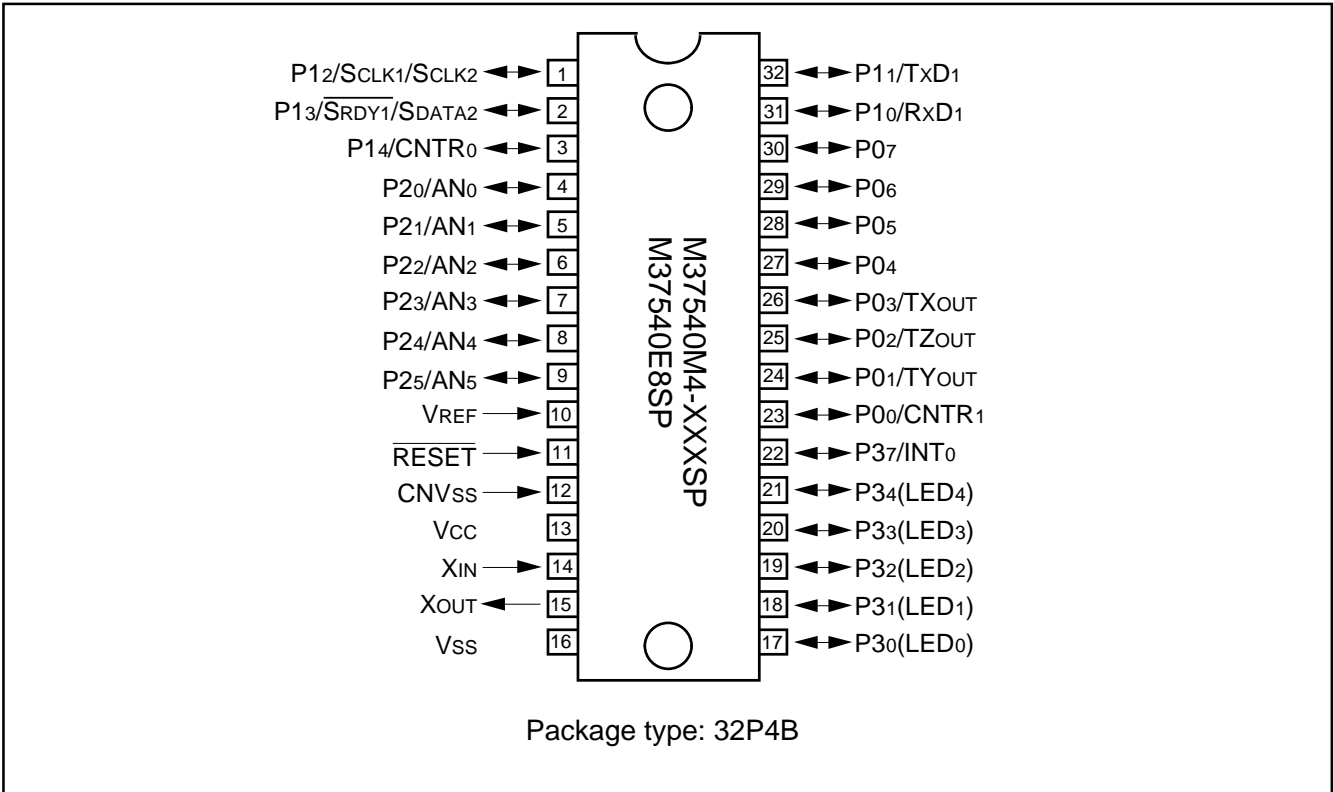

Fig. 3 M37540M4-XXXSP, M37540E8SP pin configuration

PRELIMINARY
 Notice: This is not a final specification.
 Some parametric limits are subject to change.

FUNCTIONAL BLOCK

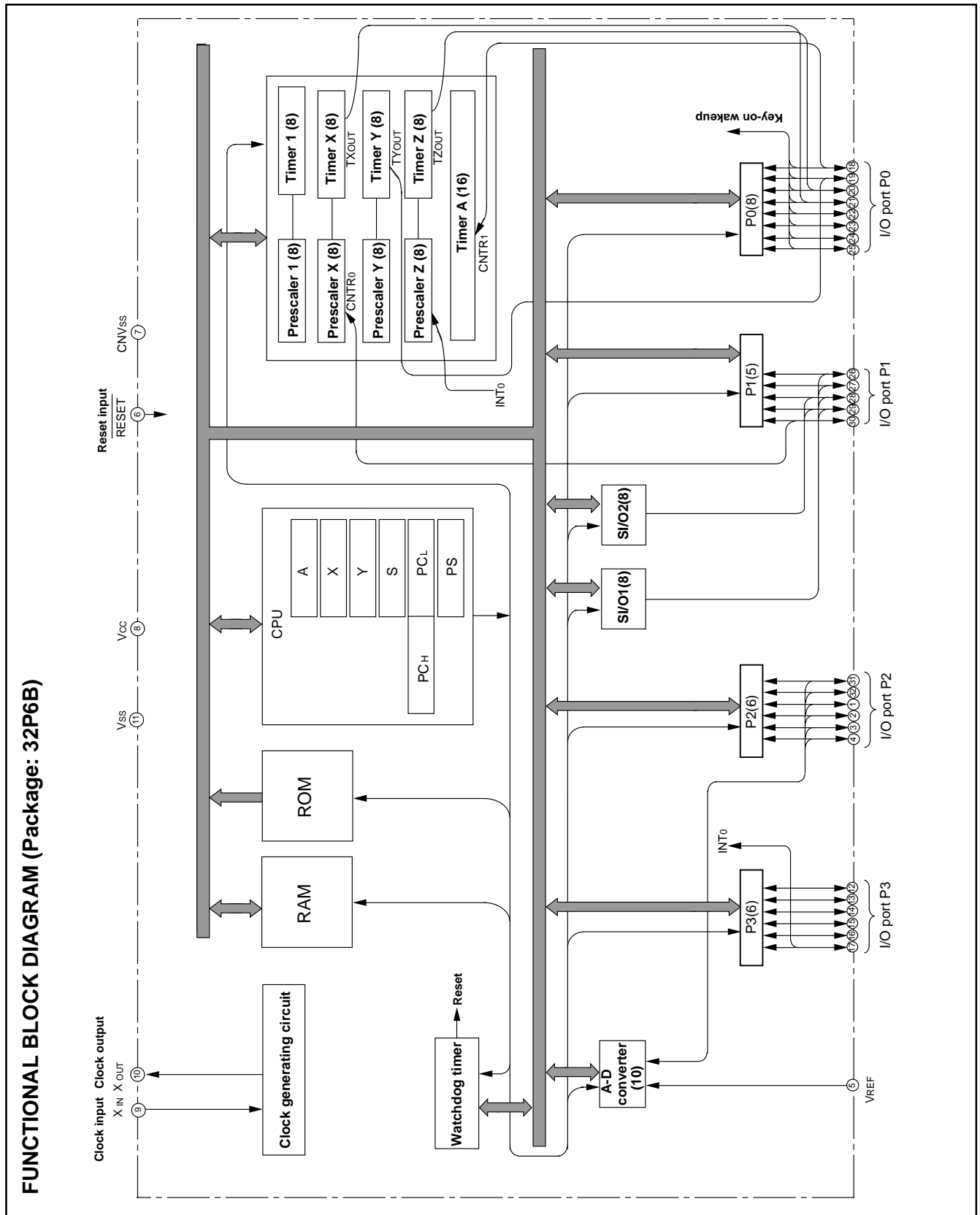

Fig. 4 Functional block diagram (32P6B package)

PRELIMINARY
 Notice: This is not a final specification.
 Some parametric limits are subject to change.

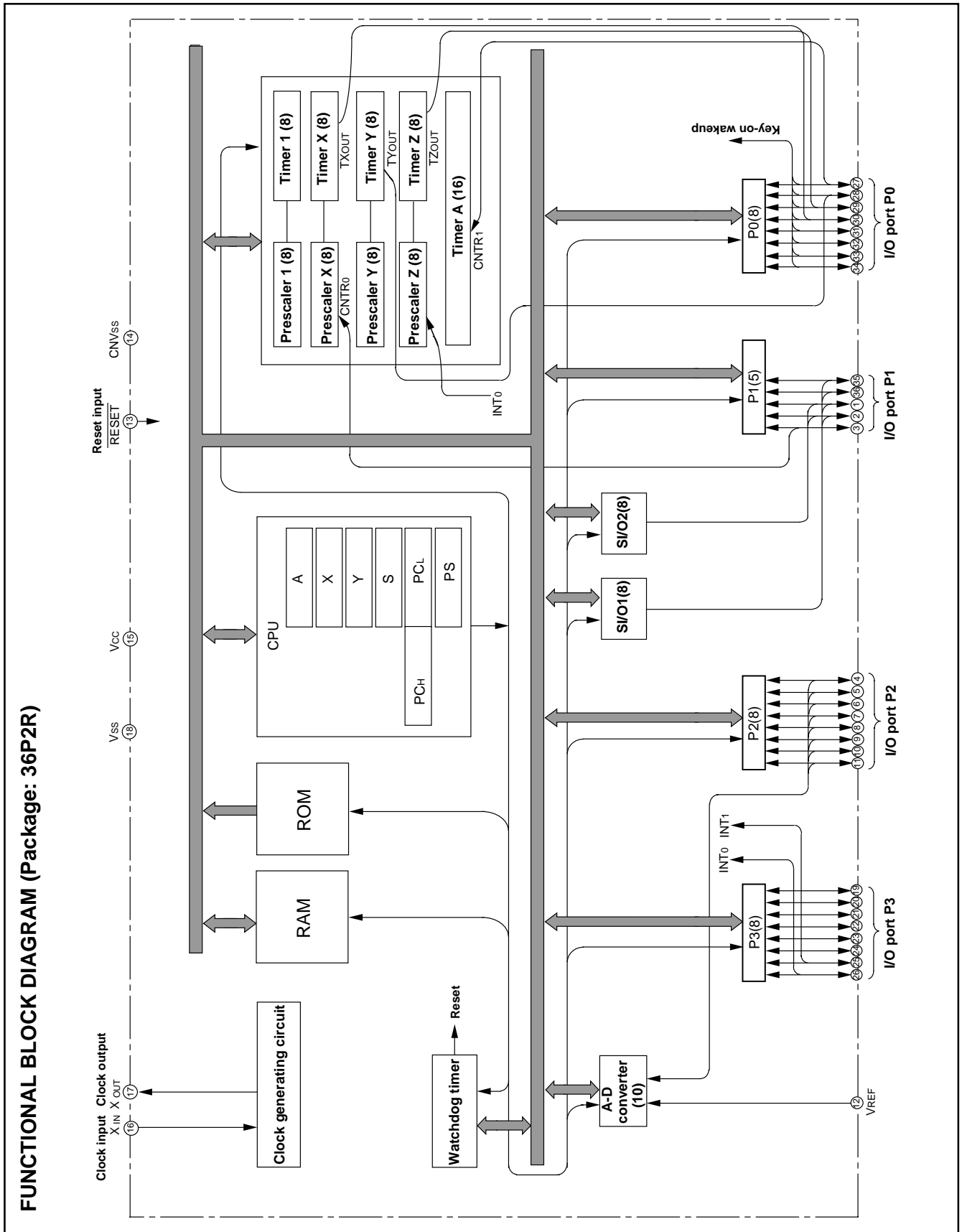

Fig. 5 Functional block diagram (36P2R package)

PRELIMINARY
 Notice: This is not a final specification.
 Some parametric limits are subject to change.

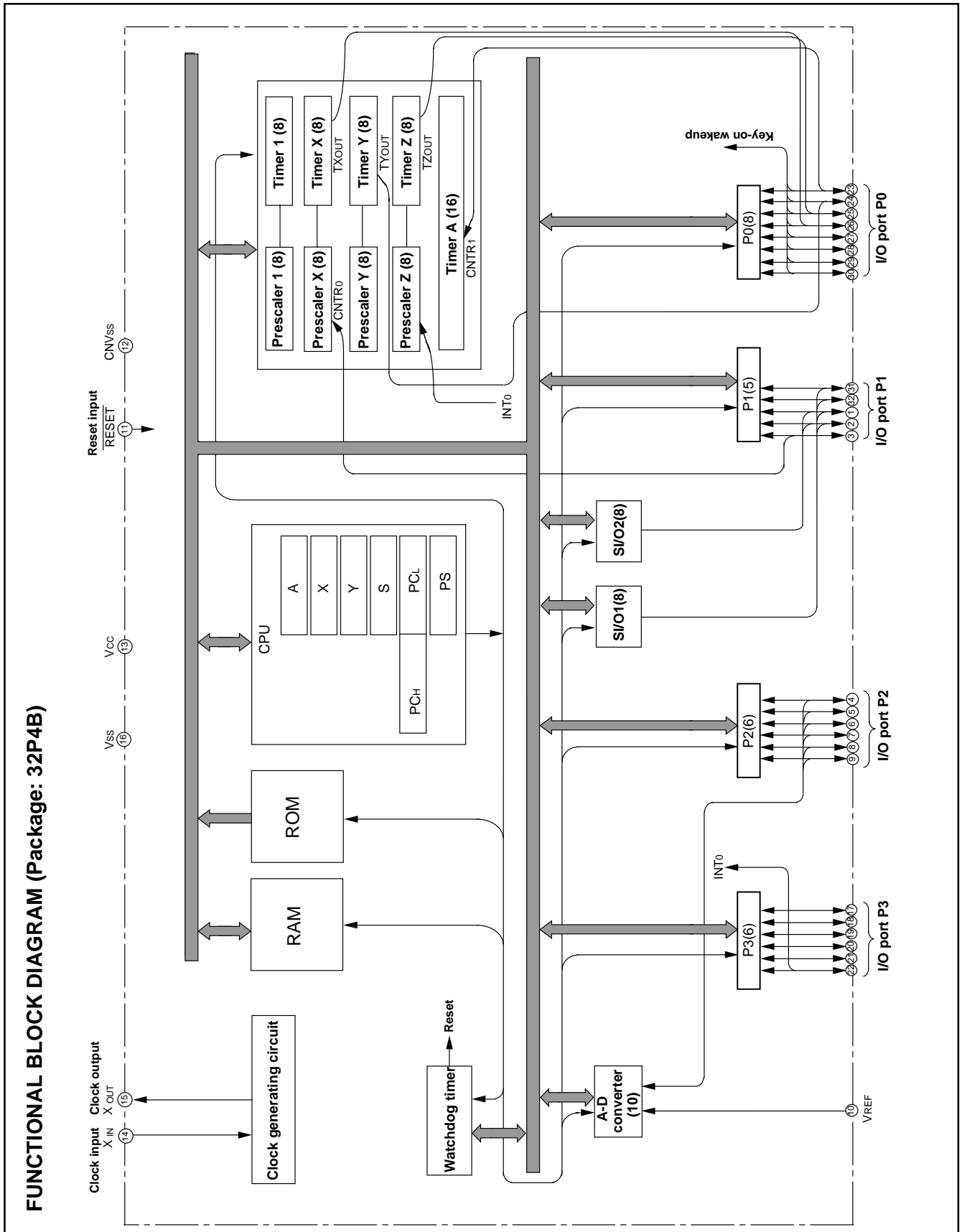

Fig. 6 Functional block diagram (32P4B package)

PRELIMINARY
 Notice: This is not a final specification.
 Some parametric limits are subject to change.

PIN DESCRIPTION

Table 1 Pin description

Pin	Name	Function	Function expect a port function
Vcc, Vss	Power source	•Apply voltage of 2.2–5.5 V to Vcc, and 0 V to Vss.	
VREF	Analog reference voltage	•Reference voltage input pin for A-D converter	
CNVss	CNVss	•Chip operating mode control pin, which is always connected to Vss.	
RESET	Reset input	•Reset input pin for active “L”	
XIN	Clock input	•Input and output pins for main clock generating circuit •Connect a ceramic resonator or quartz crystal oscillator between the XIN and XOUT pins.	
XOUT	Clock output	•For using RC oscillator, short between the XIN and XOUT pins, and connect the capacitor and resistor. •If an external clock is used, connect the clock source to the XIN pin and leave the XOUT pin open.	
P00/CNTR1 P01/TYOUT P02/TZOUT P03/TXOUT P04–P07	I/O port P0	•8-bit I/O port. •I/O direction register allows each pin to be individually programmed as either input or output. •CMOS compatible input level •CMOS 3-state output structure •Whether a built-in pull-up resistor is to be used or not can be determined by program.	•Key-input (key-on wake up interrupt input) pins •Timer Y, timer Z, timer X and timer A function pin
P10/RxD1 P11/TxD1	I/O port P1	•5-bit I/O port •I/O direction register allows each pin to be individually programmed as either input or output. •CMOS compatible input level •CMOS 3-state output structure •CMOS/TTL level can be switched for P10, P12 and P13	•Serial I/O1 function pin
P12/SCLK1/SCLK2 P13/SRDY1/SDATA2			•Serial I/O1 function pin •Serial I/O2 function pin
P14/CNTR0			•Timer X function pin
P20/AN0– P27/AN7	I/O port P2	•8-bit I/O port having almost the same function as P0 •CMOS compatible input level •CMOS 3-state output structure	•Input pins for A-D converter
P30–P35	I/O port P3	•8-bit I/O port •I/O direction register allows each pin to be individually programmed as either input or output. •CMOS compatible input level (CMOS/TTL level can be switched for P36 and P37). •CMOS 3-state output structure •P30 to P36 can output a large current for driving LED.	
P36/INT1 P37/INT0		•Whether a built-in pull-up resistor is to be used or not can be determined by program.	•Interrupt input pins

PRELIMINARY
 Notice: This is not a final specification.
 Some parametric limits are subject to change.

GROUP EXPANSION

Mitsubishi plans to expand the 7540 group as follow:

Memory type

Support for Mask ROM version, One Time PROM version, and Emulator MCU .

Memory size

ROM/PROM size 16 K to 32 K bytes
 RAM size 512 to 768 bytes

Package

32P4B 32-pin shrink plastic molded DIP
 32P6B-A 0.8 mm-pitch plastic molded QFP
 36P2R-A 0.8 mm-pitch plastic molded SOP
 42S1M 42-pin shrink ceramic PIGGY BACK

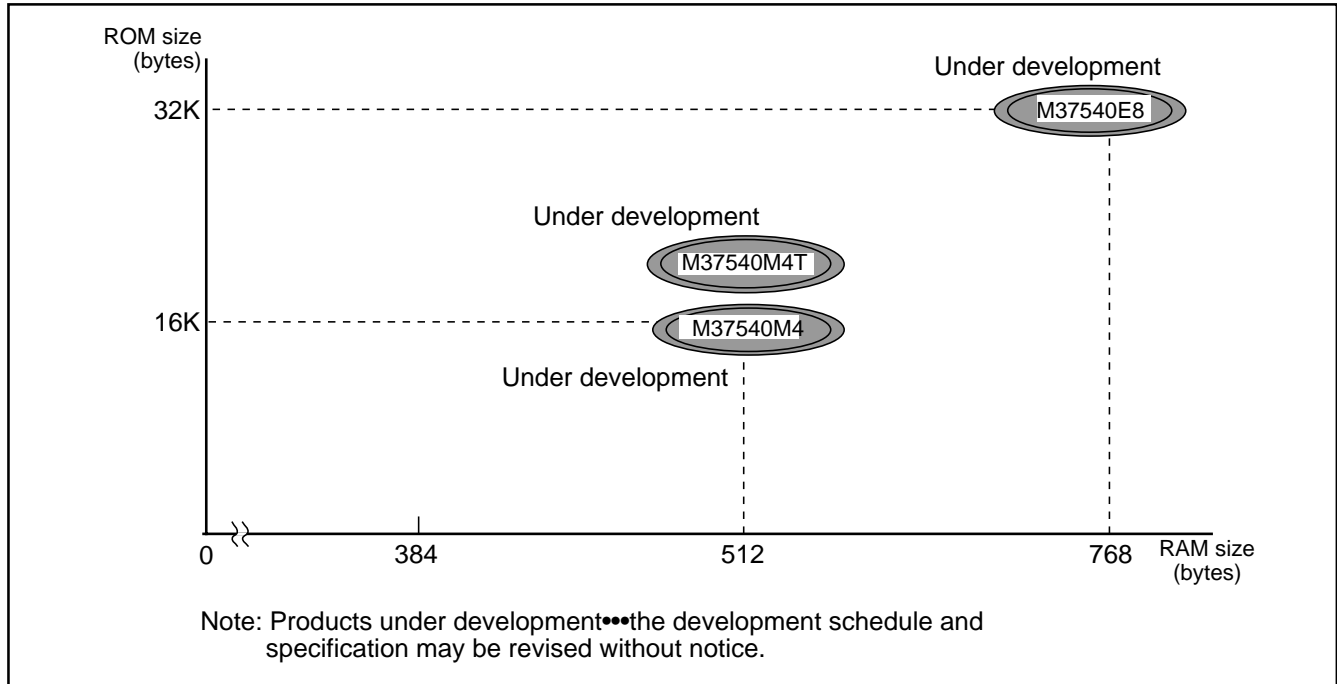

Fig. 7 Memory expansion plan

Currently supported products are listed below.

Table 2 List of supported products

Product	(P) ROM size (bytes) ROM size for User ()	RAM size (bytes)	Package	Remarks
M37540M4-XXXSP	16384 (16254)	512	32P4B	Mask ROM version
M37540M4-XXXFP			36P2R-A	Mask ROM version
M37540M4T-XXXFP				Mask ROM version (extended operating temperature version)
M37540M4-XXXGP			32P6B-A	Mask ROM version
M37540M4T-XXXGP				Mask ROM version (extended operating temperature version)
M37540E8SP	32768 (32638)	768	32P4B	One Time PROM version (blank)
M37540E8FP			36P2R-A	One Time PROM version (blank)
M37540E8GP			32P6B-A	One Time PROM version (blank)
M37540RSS	—————	768	42S1M	Emulator MCU

PRELIMINARY
 Notice: This is not a final specification.
 Some parametric limits are subject to change.

FUNCTIONAL DESCRIPTION

Central Processing Unit (CPU)

The 7540 Group uses the standard 740 family instruction set. Refer to the table of 740 family addressing modes and machine-language instructions or the 740 Family Software MANUAL for details on each instruction set.

Machine-resident 740 family instructions are as follows:

1. The FST and SLW instructions cannot be used.
2. The MUL and DIV instructions can be used.
3. The WIT instruction can be used.
4. The STP instruction can be used.

(This instruction cannot be used while CPU operates by a ring oscillator.)

[CPU mode register] CPUM

The CPU mode register contains the stack page selection bit. This register is allocated at address 003B₁₆.

Switching method of CPU mode register

Switch the CPU mode register (CPUM) at the head of program after releasing Reset in the following method.

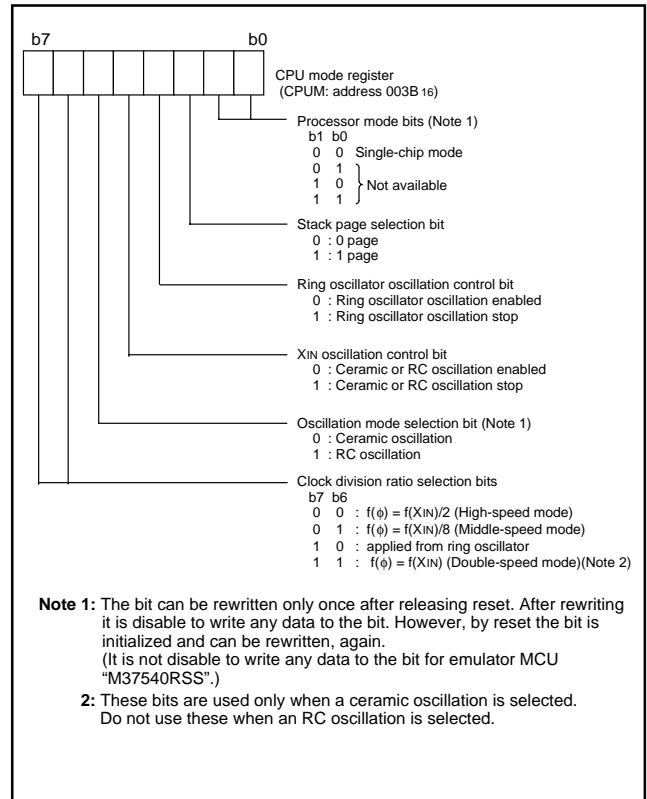

Fig. 8 Structure of CPU mode register

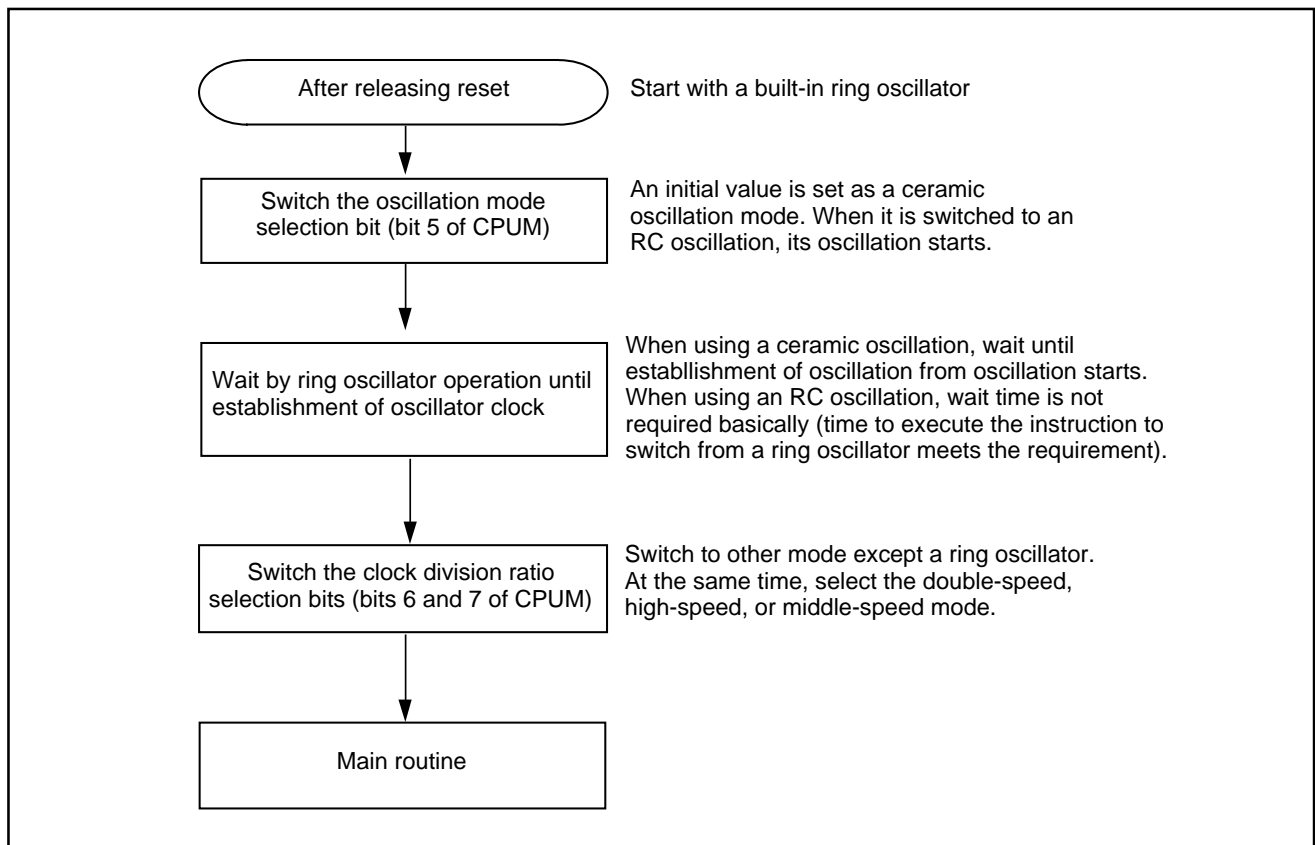

Fig. 9 Switching method of CPU mode register

Memory

Special function register (SFR) area

The SFR area in the zero page contains control registers such as I/O ports and timers.

RAM

RAM is used for data storage and for a stack area of subroutine calls and interrupts.

ROM

The first 128 bytes and the last 2 bytes of ROM are reserved for device testing and the rest is a user area for storing programs.

Interrupt vector area

The interrupt vector area contains reset and interrupt vectors.

Zero page

The 256 bytes from addresses 0000₁₆ to 00FF₁₆ are called the zero page area. The internal RAM and the special function registers (SFR) are allocated to this area.

The zero page addressing mode can be used to specify memory and register addresses in the zero page area. Access to this area with only 2 bytes is possible in the zero page addressing mode.

Special page

The 256 bytes from addresses FF00₁₆ to FFFF₁₆ are called the special page area. The special page addressing mode can be used to specify memory addresses in the special page area. Access to this area with only 2 bytes is possible in the special page addressing mode.

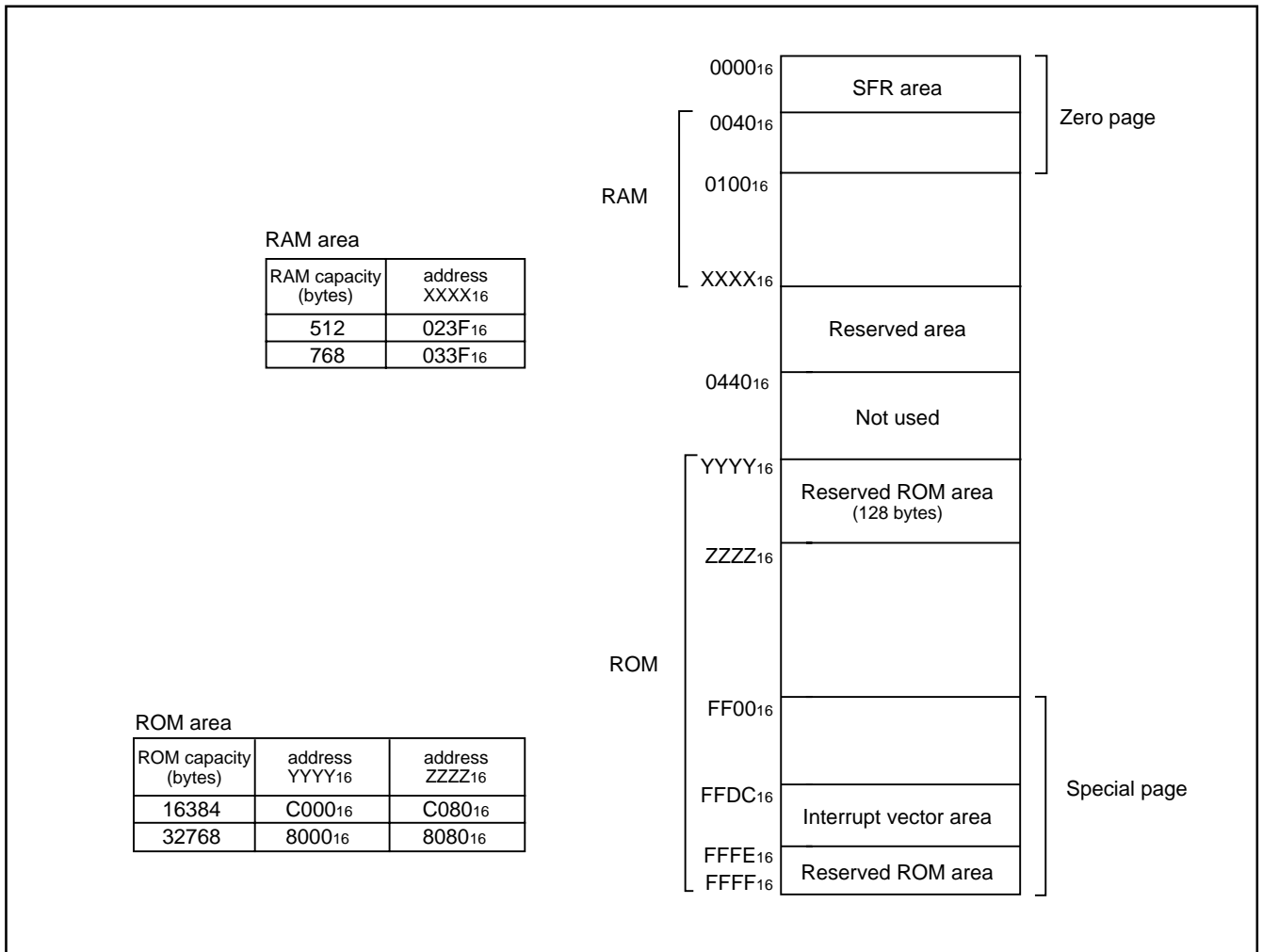

Fig. 10 Memory map diagram

0000 ₁₆	Port P0 (P0)	0020 ₁₆	Timer Y, Z mode register (TYZM)
0001 ₁₆	Port P0 direction register (P0D)	0021 ₁₆	Prescaler Y (PREY)
0002 ₁₆	Port P1 (P1)	0022 ₁₆	Timer Y secondary (TYS)
0003 ₁₆	Port P1 direction register (P1D)	0023 ₁₆	Timer Y primary (TYP)
0004 ₁₆	Port P2 (P2)	0024 ₁₆	Timer Y, Z waveform output control register (PUM)
0005 ₁₆	Port P2 direction register (P2D)	0025 ₁₆	Prescaler Z (PREZ)
0006 ₁₆	Port P3 (P3)	0026 ₁₆	Timer Z secondary (TZS)
0007 ₁₆	Port P3 direction register (P3D)	0027 ₁₆	Timer Z primary (TZP)
0008 ₁₆		0028 ₁₆	Prescaler 1 (PRE1)
0009 ₁₆		0029 ₁₆	Timer 1 (T1)
000A ₁₆		002A ₁₆	One-shot start register (ONS)
000B ₁₆		002B ₁₆	Timer X mode register (TXM)
000C ₁₆		002C ₁₆	Prescaler X (PREX)
000D ₁₆		002D ₁₆	Timer X (TX)
000E ₁₆		002E ₁₆	Timer count source set register (TCSS)
000F ₁₆		002F ₁₆	
0010 ₁₆		0030 ₁₆	Serial I/O2 control register (SIO2CON)
0011 ₁₆		0031 ₁₆	Serial I/O2 register (SIO2)
0012 ₁₆		0032 ₁₆	
0013 ₁₆		0033 ₁₆	
0014 ₁₆		0034 ₁₆	A-D control register (ADCON)
0015 ₁₆		0035 ₁₆	A-D conversion register (low-order) (ADL)
0016 ₁₆	Pull-up control register (PULL)	0036 ₁₆	A-D conversion register (high-order) (ADH)
0017 ₁₆	Port P1P3 control register (P1P3C)	0037 ₁₆	
0018 ₁₆	Transmit/Receive buffer register (TB/RB)	0038 ₁₆	MISRG
0019 ₁₆	Serial I/O1 status register (SIO1STS)	0039 ₁₆	Watchdog timer control register (WDTCN)
001A ₁₆	Serial I/O1 control register (SIO1CON)	003A ₁₆	Interrupt edge selection register (INTEDGE)
001B ₁₆	UART control register (UARTCON)	003B ₁₆	CPU mode register (CPUM)
001C ₁₆	Baud rate generator (BRG)	003C ₁₆	Interrupt request register 1 (IREQ1)
001D ₁₆	Timer A mode register (TAM)	003D ₁₆	Interrupt request register 2 (IREQ2)
001E ₁₆	Timer A (low-order) (TAL)	003E ₁₆	Interrupt control register 1 (ICON1)
001F ₁₆	Timer A (high-order) (TAH)	003F ₁₆	Interrupt control register 2 (ICON2)

Note : Do not access to the SFR area including nothing.

Fig. 11 Memory map of special function register (SFR)

PRELIMINARY
 Notice: This is not a final specification.
 Some parametric limits are subject to change.

I/O Ports

[Direction registers] PiD

The I/O ports have direction registers which determine the input/output direction of each pin. Each bit in a direction register corresponds to one pin, and each pin can be set to be input or output.

When "1" is set to the bit corresponding to a pin, this pin becomes an output port. When "0" is set to the bit, the pin becomes an input port. When data is read from a pin set to output, not the value of the pin itself but the value of port latch is read. Pins set to input are floating, and permit reading pin values.

If a pin set to input is written to, only the port latch is written to and the pin remains floating.

[Pull-up control register] PULL

By setting the pull-up control register (address 0016₁₆), ports P0 and P3 can exert pull-up control by program. However, pins set to output are disconnected from this control and cannot exert pull-up control.

[Port P1P3 control register] P1P3C

By setting the port P1P3 control register (address 0017₁₆), a CMOS input level or a TTL input level can be selected for ports P10, P12, P13, P36, and P37 by program.

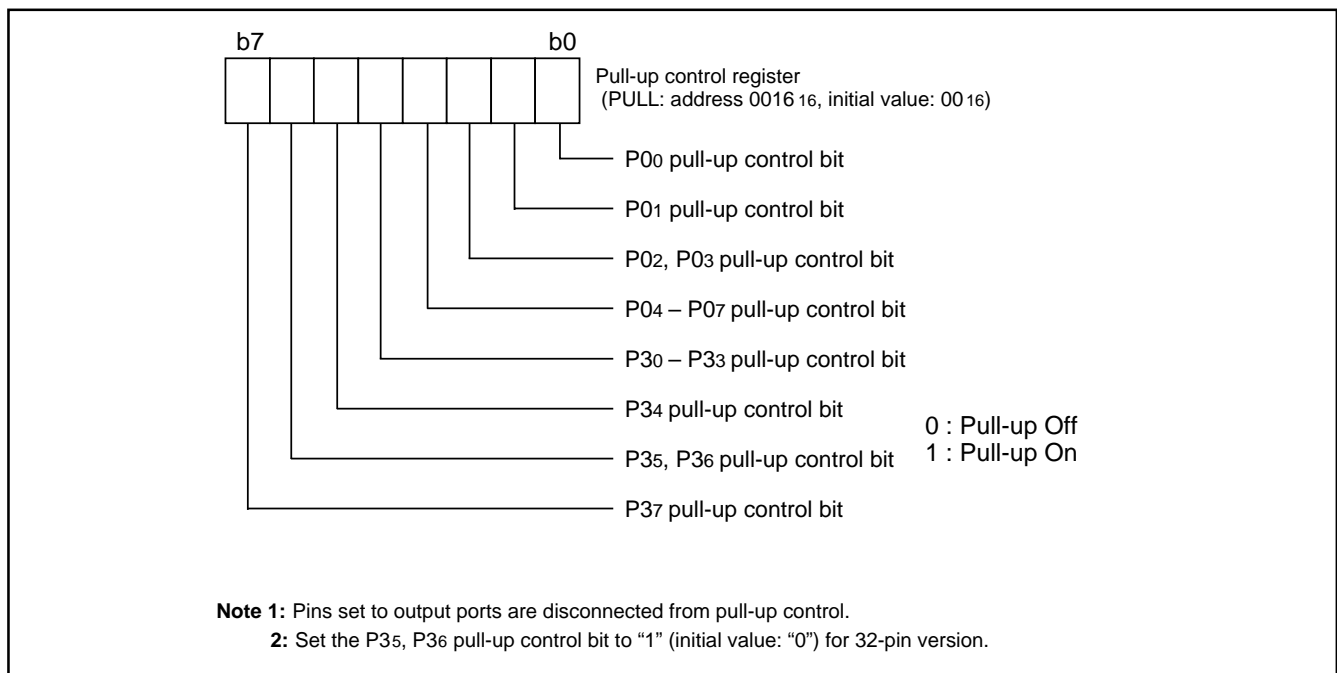

Fig. 12 Structure of pull-up control register

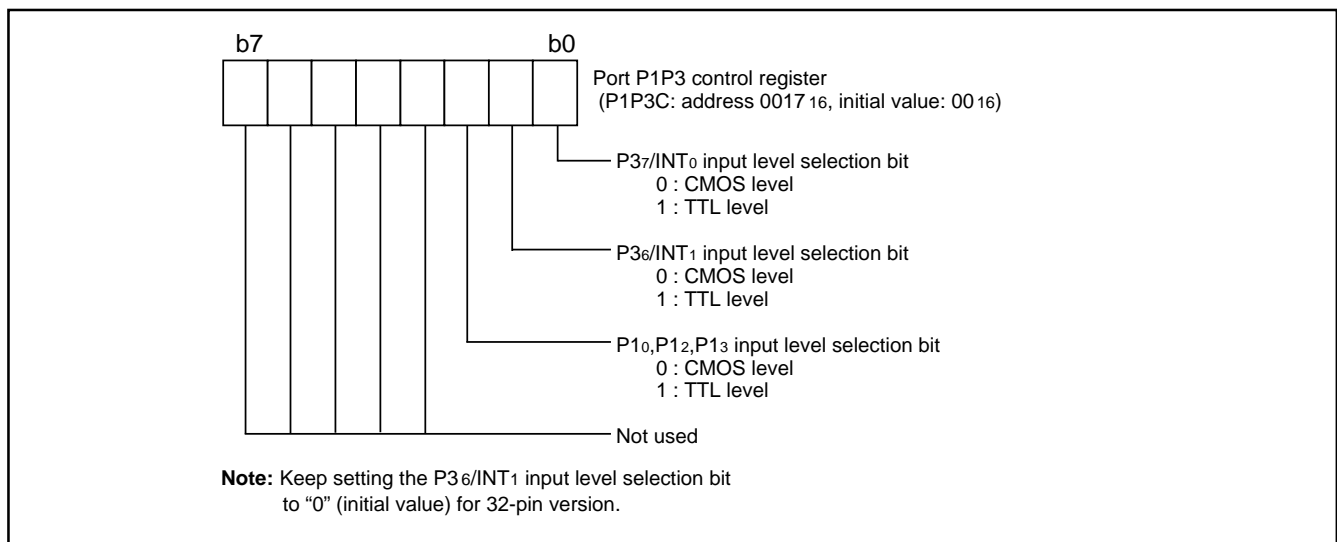

Fig. 13 Structure of port P1P3 control register

PRELIMINARY
 Notice: This is not a final specification.
 Some parametric limits are subject to change.

Table 3 I/O port function table

Pin	Name	Input/output	I/O format	Non-port function	Related SFRs	Diagram No.
P00/CNTR1 P01/TYOUT P02/TZOUT P03/TXOUT P04–P07	I/O port P0	I/O individual bits	•CMOS compatible input level •CMOS 3-state output (Note)	Key input interrupt	Pull-up control register Timer Y mode register Timer Z mode register Timer X mode register Timer Y,Z waveform output control register Timer A mode register	(1) (2) (3) (4)
P10/RxD1 P11/TxD1	I/O port P1			Serial I/O1 function input/output	Serial I/O1 control register	(5) (6)
P12/SCLK1/SCLK2 P13/SRDY1/SDATA2				Serial I/O2 function input/output	Serial I/O1 control register Serial I/O2 control register	(7) (8)
P14/CNTR0				Timer X function input/output	Timer X mode register	(9)
P20/AN0–P27/AN7	I/O port P2			A-D conversion input	A-D control register	(10)
P30–P35	I/O port P3					(11)
P36/INT1 P37/INT0				External interrupt input	Interrupt edge selection register	(12)

Note: Ports P10, P12, P13, P36, and P37 are CMOS/TTL level.

PRELIMINARY
 Notice: This is not a final specification.
 Some parametric limits are subject to change.

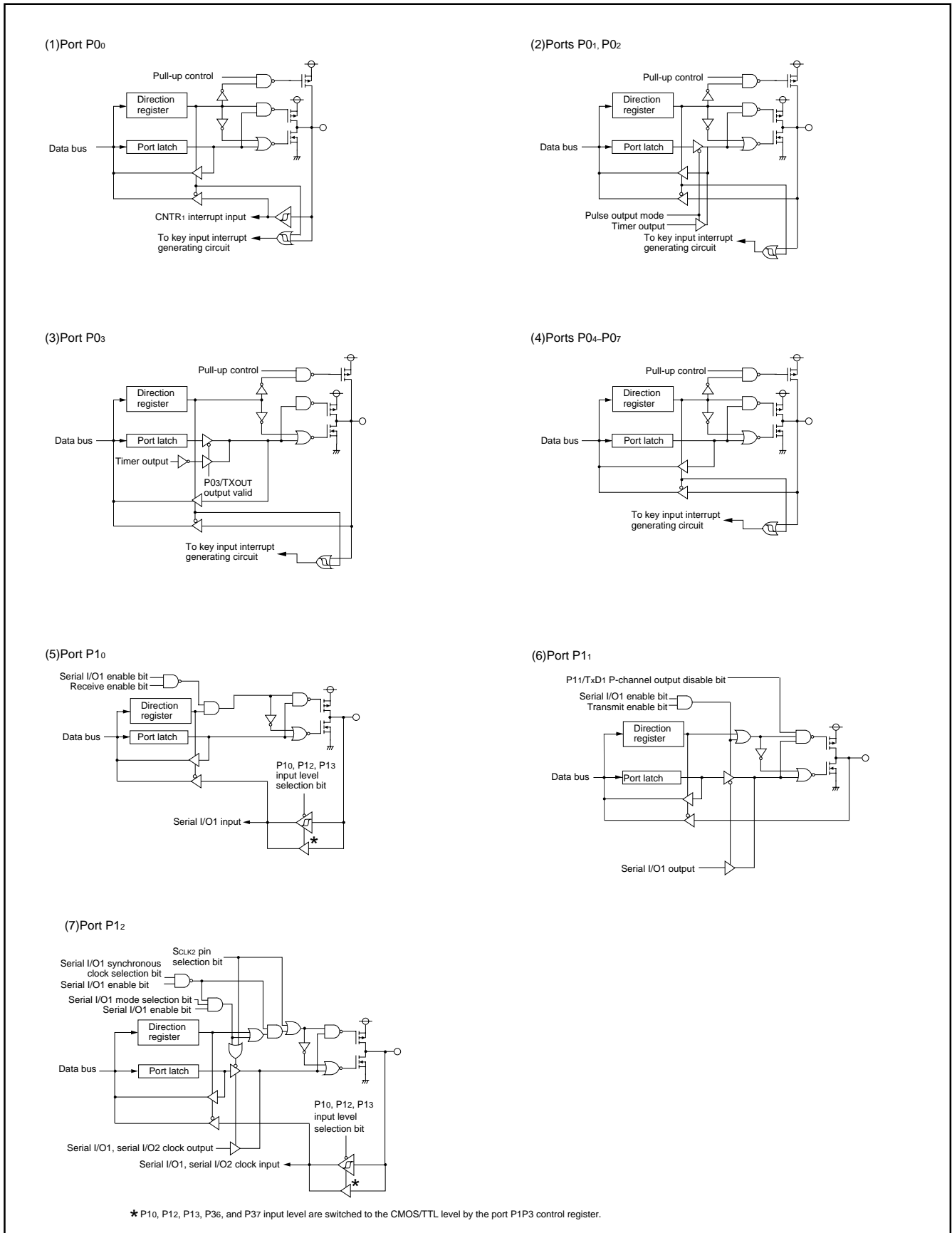
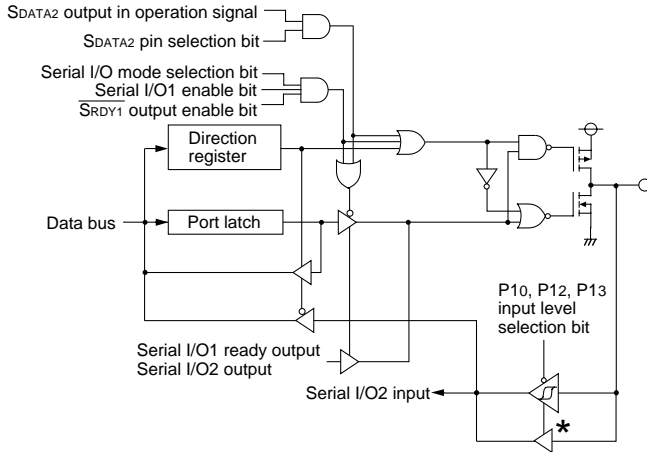

Fig. 14 Block diagram of ports (1)

PRELIMINARY
 Notice: This is not a final specification.
 Some parametric limits are subject to change.

(8) Port P13



(9) Port P14

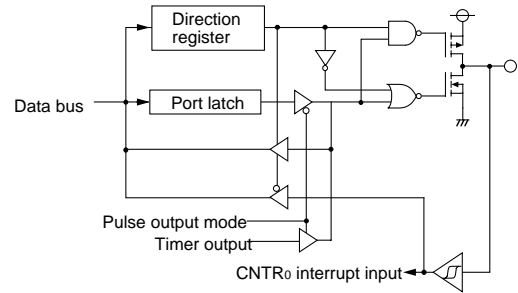

(10) Ports P20-P27

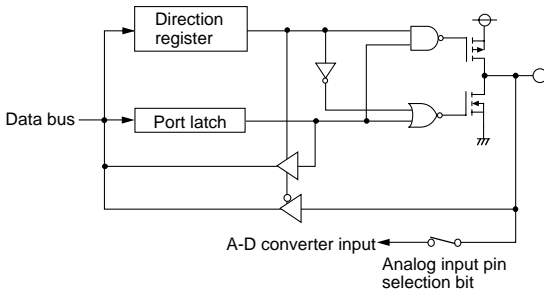

(11) Ports P30-P35

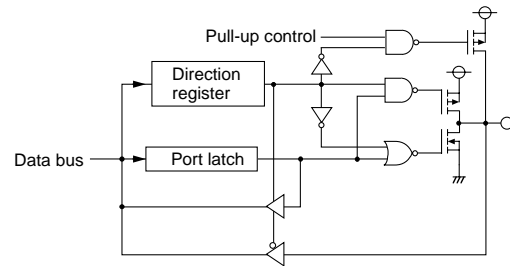

(12) Ports P36, P37

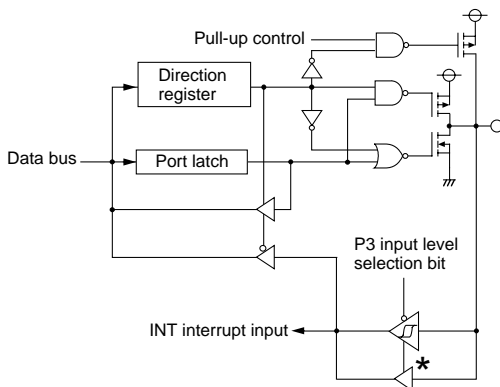

* P10, P12, P13, P36, and P37 input level are switched to the CMOS/TTL level by the port P1P3 control register.

Fig. 15 Block diagram of ports (2)

PRELIMINARY
 Notice: This is not a final specification.
 Some parametric limits are subject to change.

Interrupts

Interrupts occur by 15 different sources : 5 external sources, 9 internal sources and 1 software source.

Interrupt control

All interrupts except the BRK instruction interrupt have an interrupt request bit and an interrupt enable bit, and they are controlled by the interrupt disable flag. When the interrupt enable bit and the interrupt request bit are set to "1" and the interrupt disable flag is set to "0", an interrupt is accepted.

The interrupt request bit can be cleared by program but not be set.

The interrupt enable bit can be set and cleared by program.

The reset and BRK instruction interrupt can never be disabled with any flag or bit. All interrupts except these are disabled when the interrupt disable flag is set.

When several interrupts occur at the same time, the interrupts are received according to priority.

Interrupt operation

Upon acceptance of an interrupt the following operations are automatically performed:

1. The processing being executed is stopped.
2. The contents of the program counter and processor status register are automatically pushed onto the stack.
3. The interrupt disable flag is set and the corresponding interrupt request bit is cleared.
4. Concurrently with the push operation, the interrupt destination address is read from the vector table into the program counter.

Notes on use

When the active edge of an external interrupt (INT₀, INT₁, CNTR₀) is set, the interrupt request bit may be set.

Therefore, please take following sequence:

1. Disable the external interrupt which is selected.
2. Change the active edge in interrupt edge selection register. (in case of CNTR₀: Timer X mode register, in case of CNTR₁: Timer A mode register)
3. Clear the set interrupt request bit to "0".
4. Enable the external interrupt which is selected.

Table 4 Interrupt vector address and priority

Interrupt source	Priority	Vector addresses (Note 1)		Interrupt request generating conditions	Remarks
		High-order	Low-order		
Reset (Note 2)	1	FFFD ₁₆	FFFC ₁₆	At reset input	Non-maskable
Serial I/O1 receive	2	FFFB ₁₆	FFFA ₁₆	At completion of serial I/O1 data receive	Valid only when serial I/O1 is selected
Serial I/O1 transmit	3	FFF9 ₁₆	FFF8 ₁₆	At completion of serial I/O1 transmit shift or when transmit buffer is empty	Valid only when serial I/O1 is selected
INT ₀	4	FFF7 ₁₆	FFF6 ₁₆	At detection of either rising or falling edge of INT ₀ input	External interrupt (active edge selectable)
INT ₁ (Note 3)	5	FFF5 ₁₆	FFF4 ₁₆	At detection of either rising or falling edge of INT ₁ input	External interrupt (active edge selectable)
Key-on wake-up	6	FFF3 ₁₆	FFF2 ₁₆	At falling of conjunction of input logical level for port P0 (at input)	External interrupt (valid at falling)
CNTR ₀	7	FFF1 ₁₆	FFF0 ₁₆	At detection of either rising or falling edge of CNTR ₀ input	External interrupt (active edge selectable)
CNTR ₁	8	FFEF ₁₆	FFEE ₁₆	At detection of either rising or falling edge of CNTR ₁ input	External interrupt (active edge selectable)
Timer X	9	FFED ₁₆	FFEC ₁₆	At timer X underflow	
Timer Y	10	FFEB ₁₆	FFEA ₁₆	At timer Y underflow	
Timer Z	11	FFE9 ₁₆	FFE8 ₁₆	At timer Z underflow	
Timer A	12	FFE7 ₁₆	FFE6 ₁₆	At timer A underflow	
Serial I/O2	13	FFE5 ₁₆	FFE4 ₁₆	At completion of transmit/receive shift	
A-D conversion	14	FFE3 ₁₆	FFE2 ₁₆	At completion of A-D conversion	
Timer 1	15	FFE1 ₁₆	FFE0 ₁₆	At timer 1 underflow	STP release timer underflow
Reserved area	16	FFDF ₁₆	FFDE ₁₆	Not available	
BRK instruction	17	FFDD ₁₆	FFDC ₁₆	At BRK instruction execution	Non-maskable software interrupt

Note 1: Vector addressed contain internal jump destination addresses.

2: Reset function in the same way as an interrupt with the highest priority.

3: It is an interrupt which can use only for 36 pin version.

PRELIMINARY
 Notice: This is not a final specification.
 Some parametric limits are subject to change.

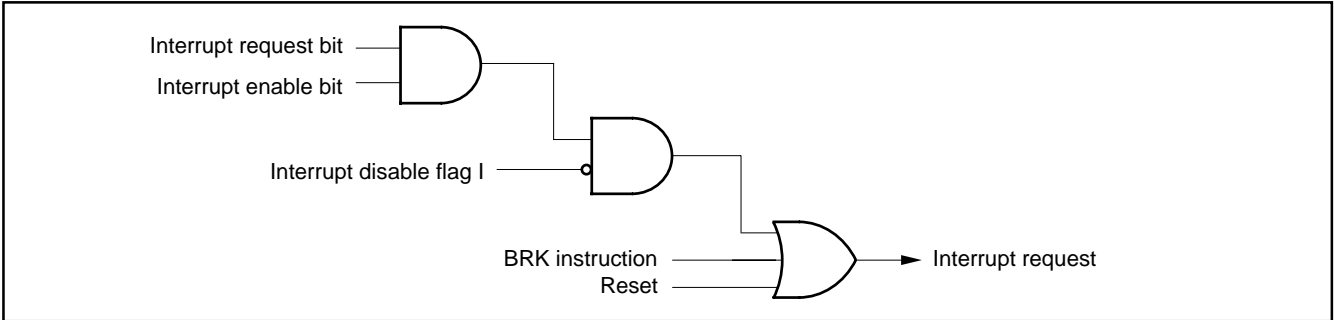

Fig. 16 Interrupt control

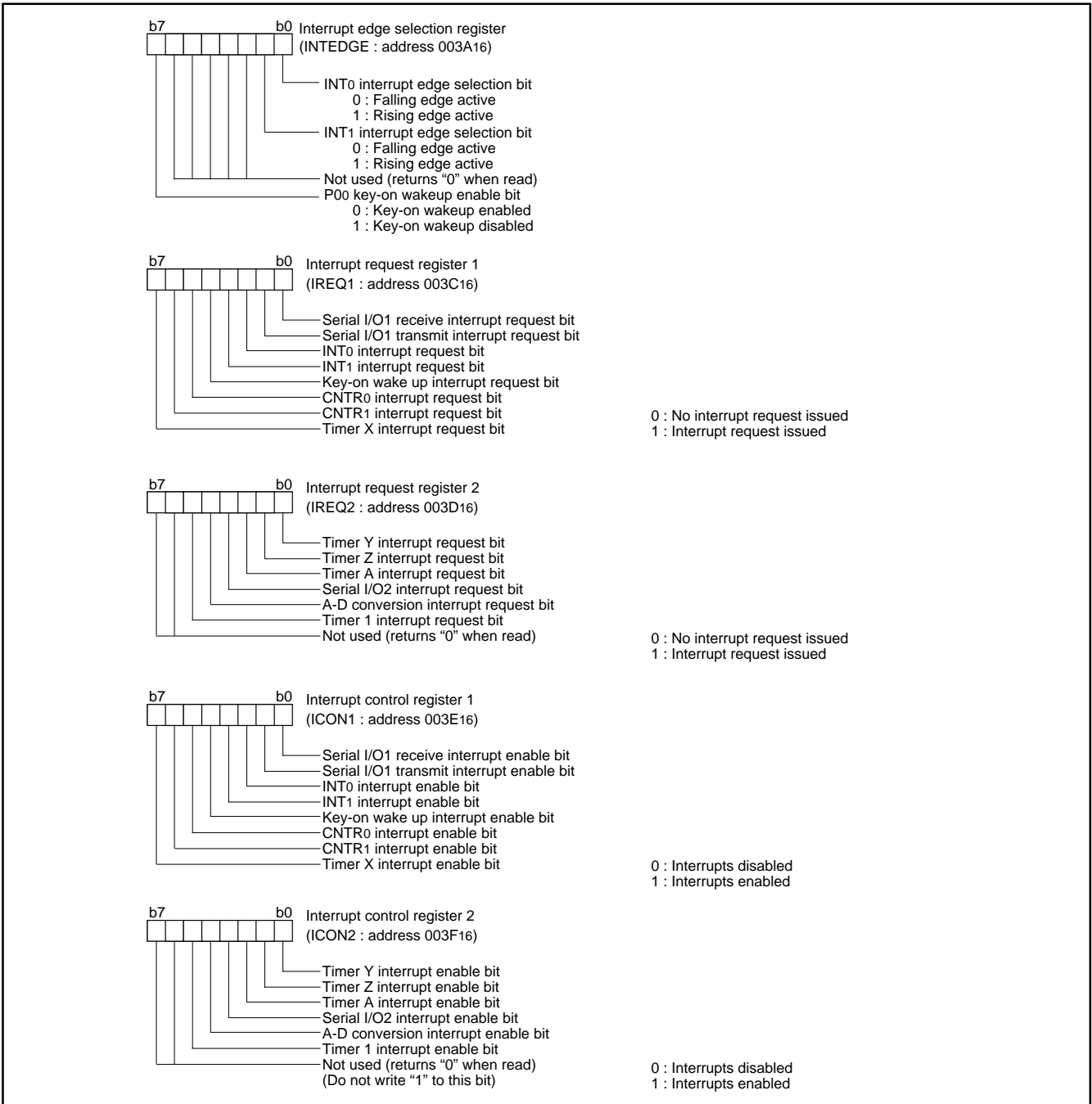

Fig. 17 Structure of Interrupt-related registers

PRELIMINARY
 Notice: This is not a final specification.
 Some parametric limits are subject to change.

Key Input Interrupt (Key-On Wake-Up)

A key-on wake-up interrupt request is generated by applying "L" level to any pin of port P0 that has been set to input mode. In other words, it is generated when the AND of input level goes from "1" to "0". An example of using a key input interrupt is shown in Figure 18, where an interrupt request is generated by pressing one of the keys provided as an active-low key matrix which uses ports P00 to P03 as input ports.

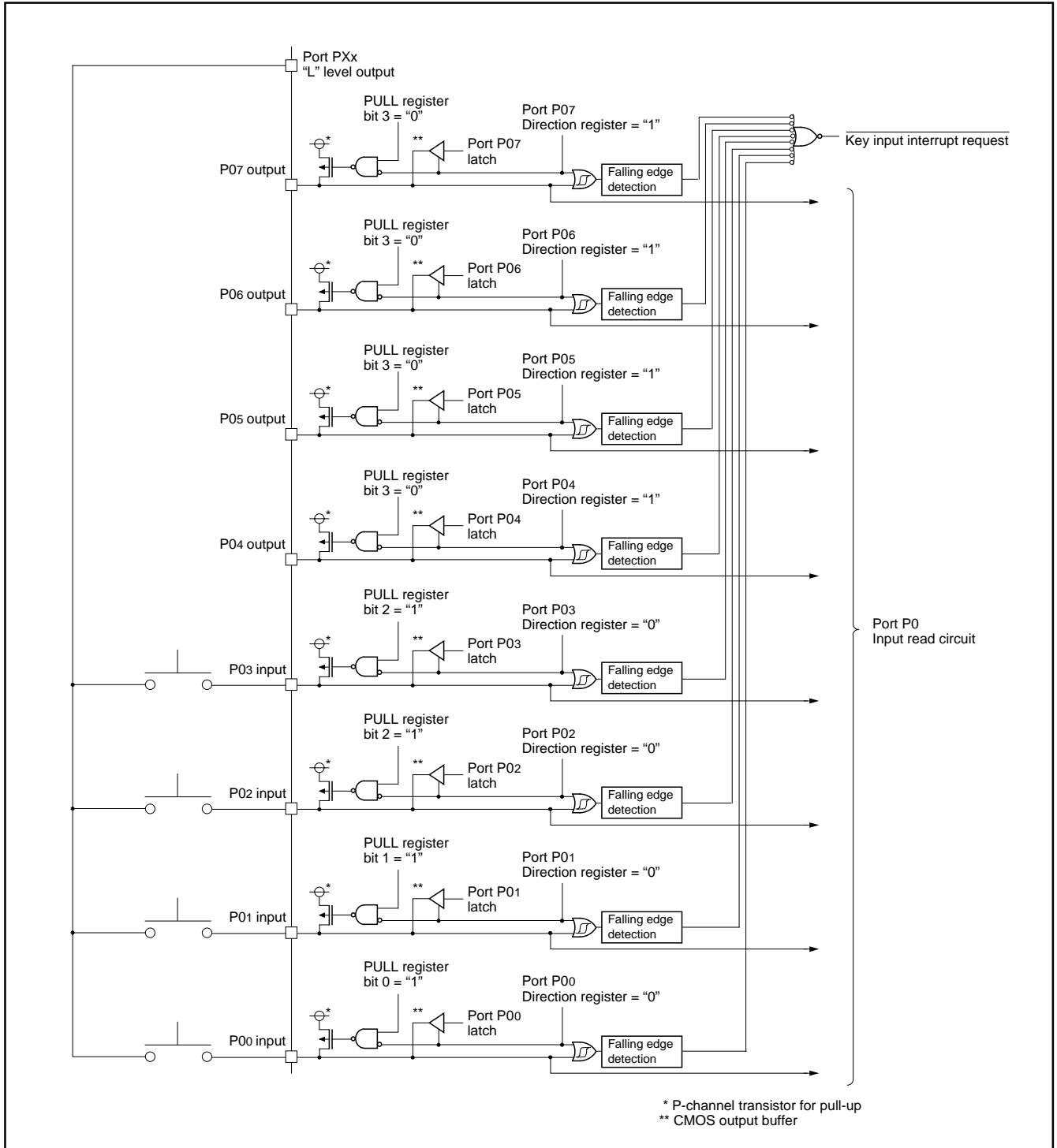

Fig. 18 Connection example when using key input interrupt and port P0 block diagram

PRELIMINARY
 Notice: This is not a final specification.
 Some parametric limits are subject to change.

Timers

The 7540 Group has 5 timers: timer 1, timer A, timer X, timer Y and timer Z.

The division ratio of every timer and prescaler is $1/(n+1)$ provided that the value of the timer latch or prescaler is n .

All the timers are down count timers. When a timer reaches "0", an underflow occurs at the next count pulse, and the corresponding timer latch is reloaded into the timer. When a timer underflows, the interrupt request bit corresponding to each timer is set to "1".

●Timer 1

Prescaler 1 always counts $f(X_{IN})/16$. Timer 1 always counts the prescaler 1 output and periodically sets the interrupt request bit.

●Timer A

Timer A is a 16-bit timer that can be selected in one of four modes.

• Timer Mode

The timer counts $f(X_{IN})/16$.

• Period Measurement Mode

CNTR₁ interrupt request is generated at rising/falling edge of CNTR₁ pin input signal. Simultaneously, the value in timer A latch is reloaded in timer A and timer A continues counting down. Except for the above-mentioned, the operation in period measurement mode is the same as in timer mode.

The timer value just before the reloading at rising/falling of CNTR₁ pin input signal is retained until the timer A is read once after the reload.

The rising/falling timing of CNTR₁ pin input signal is found by CNTR₁ interrupt.

• Event Counter Mode

The timer counts signals input through the CNTR₁ pin.

Except for this, the operation in event counter mode is the same as in timer mode.

• Pulse Width HL Continuously Measurement Mode

CNTR₁ interrupt request is generated at both rising and falling edges of CNTR₁ pin input signal. Except for this, the operation in pulse width HL continuously measurement mode is the same as in period measurement mode.

■ Note

● CNTR₁ interrupt active edge selection

CNTR₁ interrupt active edge depends on the CNTR₁ active edge switch bit. However, in pulse width HL continuously measurement mode, CNTR₁ interrupt request is generated at both rising and falling edges of CNTR₁ pin input signal regardless of the setting of CNTR₁ active edge switch bit.

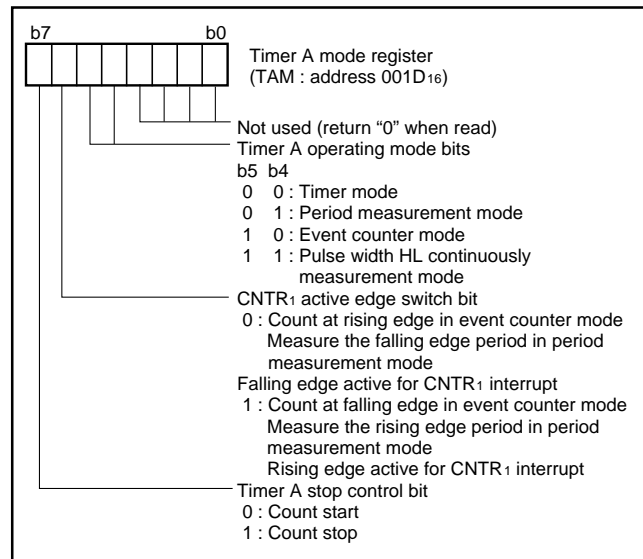

Fig. 19 Structure of timer A mode register

PRELIMINARY
 Notice: This is not a final specification.
 Some parametric limits are subject to change.

●Timer X

Timer X can be selected in one of 4 operating modes by setting the timer X mode register.

• Timer Mode

The timer counts the signal selected by the timer X count source selection bits.

• Pulse Output Mode

The timer counts the signal selected by the timer X count source selection bits, and outputs a signal whose polarity is inverted each time the timer value reaches "0", from the CNTR₀ pin.

When the CNTR₀ active edge switch bit is "0", the output of the CNTR₀ pin is started with an "H" output. At "1", this output is started with an "L" output. When using a timer in this mode, set the port P14 direction register to output mode. Also, in the pulse output mode, the inverted waveform of pulse output from CNTR₀ pin can be output from TXOUT pin by setting the P0₃/TXOUT output valid bit to "1". When using a timer in this mode, set the port P0₃ direction register to output mode.

• Event Counter Mode

The operation in the event counter mode is the same as that in the timer mode except that the timer counts the input signal from the CNTR₀ pin.

When the CNTR₀ active edge switch bit is "0", the timer counts the rising edge of the CNTR₀ pin. When this bit is "1", the timer counts the falling edge of the CNTR₀ pin.

• Pulse Width Measurement Mode

When the CNTR₀ active edge switch bit is "0", the timer counts the signal selected by the timer X count source selection bit while the CNTR₀ pin is "H". When this bit is "1", the timer counts the signal while the CNTR₀ pin is "L".

In any mode, the timer count can be stopped by setting the timer X count stop bit to "1". Each time the timer overflows, the interrupt request bit is set.

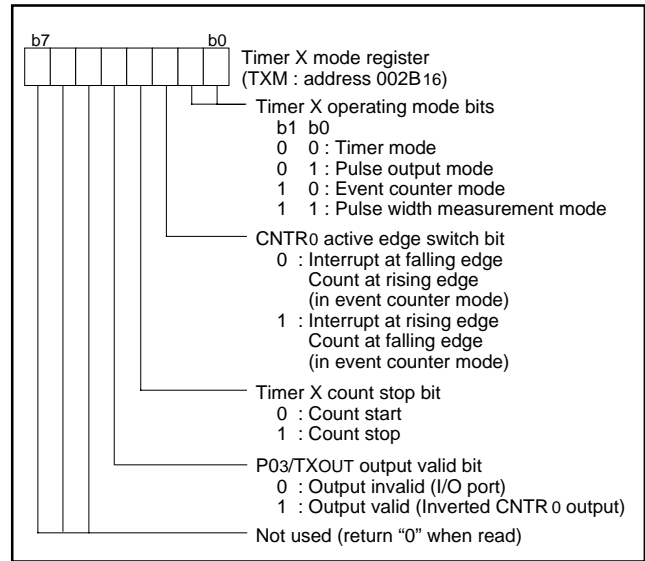

Fig. 20 Structure of timer X mode register

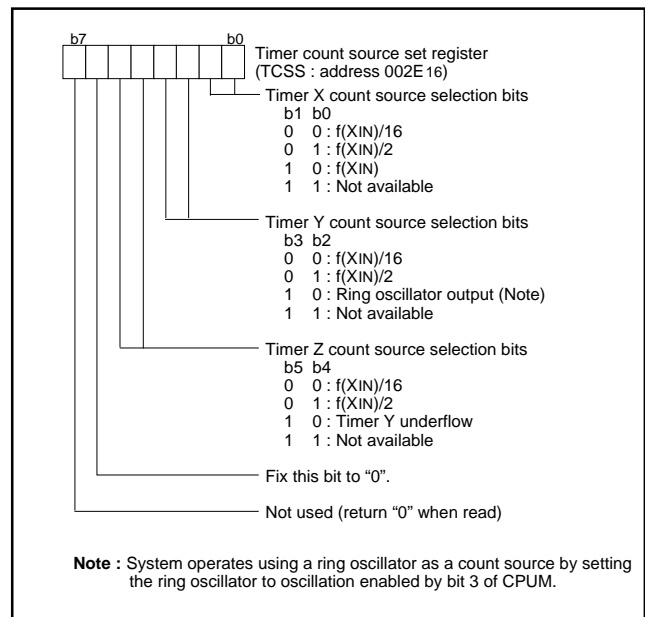

Fig. 21 Timer count source set register

PRELIMINARY
 Notice: This is not a final specification.
 Some parametric limits are subject to change.

●Timer Y

Timer Y is an 8-bit timer and can be selected in one of 2 operating modes by setting the timer Y, Z mode register (TYZM).

- Timer mode
- Programmable waveform generation mode

The division ratio of timer Y and prescaler Y is $1/(n+1)$ provided that the value of the timer latch or prescaler Y latch is n.

(1)Timer mode

- Mode select
Timer mode is selected by setting timer Y operation mode bit (b0) of TYZM to "0".
- Count source select
The count source is $f(X_{IN})/2$ or $f(X_{IN})/16$.
- Interrupt
When an underflow occurs, timer Y interrupt request bit (b0) of IREQ2 is set to "1".
- Operation description
After reset release, timer Y is operating because the timer Y count stop bit (b3) of TYZM is "0". Timer operation is stopped by setting b3 of TYZM to "1". In the timer mode, the timer count value is set by timer Y primary latch (TYP). When a value is set to TYP while timer is stopped, the setting value is written to latch and timer simultaneously.
When timer Y reaches "00", an underflow occurs at the next count pulse, and the timer Y latch is reloaded into the timer and count continues. When timer value is changed during the count operation, either "writing to latch and timer simultaneously" or "writing to only latch" can be selected by setting the timer Y write control bit (b2) of TYZM. When selecting "writing to only latch", the timer count value is changed after the next underflow.

(2)Programmable waveform generation mode

- Mode select
Timer mode is selected by setting timer Y operation mode bit (b0) of TYZM to "1".
When this mode is selected, set timer Y write control bit (b2) of TYZM to "1" ("writing to only latch" selected).
- Count source select
The count source is $f(X_{IN})/2$ or $f(X_{IN})/16$.
- Interrupt
When an underflow occurs, timer Y interrupt request bit (b0) of IREQ is set to "1".

• Operation description

After reset release, timer Y is operating because the timer Y count stop bit (b3) of TYZM is "0". MCU operates in the programmable waveform generation mode when timer Y operation mode bit (b0) of TYZM is set to "1" and b3 to "0" after timer Y operation is stopped by setting b3 of TYZM to "1".

In the programmable waveform generation mode, timer counts the setting value of timer Y primary latch (TYP) and the setting value of timer Y secondary latch (TYS) alternately, the waveform inverted each time TYP and TYS underflow is output from TYOUT pin. The active edge of output waveform is set by the timer Y output level latch (b4) of the timer Y, Z waveform output control register (PUM). When "0" is set to b4 of PUM, the initial state of timer at stop is "L", and "H" interval by the setting value of TYP or "L" interval by the setting value of TYS is output alternately. When "1" is set to b4 of PUM, the initial state of timer at stop is "H", and "L" interval by the setting value of TYP or "H" interval by the setting value of TYS is output alternately.

Also, in this mode, the primary interval and the secondary interval of the output waveform can be extended respectively for 0.5 cycle of timer count source clock by setting the timer Y primary waveform extension control bit (b0) and the timer Y secondary waveform extension control bit (b1) of PUM to "1". As a result, the waveforms of more accurate resolution can be output.

When b0 and b1 of PUM are used, the frequency and duty of the output waveform are as follows;

Waveform frequency:

$$FTYOUT = (2 \times TMCL) / (2 \times (TYP + 1) + 2 \times (TYS) + (EXPYP + EXPYS))$$

Duty:

$$DTYOUT = (2 \times (TYP + 1) + EXPYP) / (2 \times (TYS + 1) + EXPYS)$$

TMCL: Timer Y count clock $f(X_{IN})/2$ or $f(X_{IN})/16$

TYP: Timer Y primary latch (8 bits)

TYS: Timer Y secondary latch (8 bits)

EXPYP: Timer Y primary waveform extension control bit (1 bit)

EXPYS: Timer Y secondary waveform extension control bit (1 bit)

When using the programmable waveform generation mode, note the following;

Notes on using the programmable waveform generation mode

- When setting and changing TYP, TYS, EXPYP and EXPYS, write to TYP at last because the setting to them is executed all at once by writing to TYP. Even when TYP is not changed, write the same value. The value is reloaded to timer at the beginning of the next primary interval.
- Set by software in order not to execute the writing to timer Y primary and the timing of timer underflow simultaneously. When reading the timer Y secondary, the undefined value is read out. However, while timer counts the setting value of the timer Y secondary, the count values at the secondary interval can be identified by reading the timer Y primary.
- In this mode, set port P0₁ which is also used as TYOUT pin to output.
- B0 and b1 of PUM can be used only when "0016" is set to prescaler Y.

PRELIMINARY
 Notice: This is not a final specification.
 Some parametric limits are subject to change.

●Timer Z

Timer Z is an 8-bit timer and can be selected in one of 4 operating modes by setting the timer YZ mode register (TYZM).

- Timer mode
- Programmable waveform generation mode
- Programmable one-shot generation mode
- Programmable wait one-shot generation mode

The division ratio of timer Z and prescaler Z is $1/(n+1)$ provided that the value of the timer Z latch or prescaler Z latch is n.

(1)Timer mode

- Mode select
Timer mode is selected by setting timer Z operation mode bits (b5,b4) of TYZM to "00".
- Count source select
The count source is $f(X_{IN})/2$, $f(X_{IN})/16$ or timer Y underflow.
- Interrupt
When an underflow occurs, timer Z interrupt request bit (b1) of IREQ2 is set to "1".
- Operation description
After reset release, timer Z is operating because the timer Z count stop bit (b7) is "0". Timer operation is stopped by setting b7 of TYZM to "1". In the timer mode, the timer count value is set by timer Z primary latch (TZP). When a value is set to TZP while timer is stopped, the setting value is written to latch and timer simultaneously.

When timer Z reaches "00", an underflow occurs at the next count pulse, and the timer Z latch is reloaded into the timer and count continues. When timer value is changed during the count operation, either "writing to latch and timer simultaneously" or "writing to only latch" can be selected by setting the timer Z write control bit (b6) of TYZM. When selecting "writing to only latch", the timer count value is changed after the next underflow.

(2)Programmable waveform generation mode

- Mode select
Timer mode is selected by setting timer Z operation mode bits (b5,b4) of TYZM to "01".
When this mode is selected, set timer Z write control bit (b6) of TYZM to "1" ("writing to only latch" selected).
- Count source select
The count source is $f(X_{IN})/2$, $f(X_{IN})/16$ or timer Y underflow.
- Interrupt
When an underflow occurs, timer Z interrupt request bit (b1) of IREQ is set to "1".
- Operation description
After reset release, timer Z is operating because the timer Z count stop bit (b7) of TYZM is "0". MCU operates in the programmable waveform generation mode when timer Z operation mode bits (b5, b4) of TYZM is set to "01" and b7 to "0" after timer Z operation is stopped by setting b7 of TYZM to "1".

In the programmable waveform generation mode, timer counts the setting value of timer Z primary latch (TZP) and the setting value of timer Z secondary latch (TZS) alternately, the waveform inverted each time TZP and TZS underflow is output from TZOUT pin. The active edge of output waveform is set by the timer Z output level latch (b5) of the timer Y, Z waveform output control register (PUM). When "0" is set to b5 of PUM, the initial state of timer at stop is "L", and "H" interval by the setting value of TZP or "L" interval by the setting value of TZS is output alternately. When "1" is set to b5 of PUM, the initial state of timer at stop is "H", and "L" interval by the setting value of TZP or "H" interval by the setting value of TZS is output alternately.

Also, in this mode, the primary interval and the secondary interval of the output waveform can be extended respectively for 0.5 cycle of timer count source clock by setting the timer Z primary waveform extension control bit (b2) and the timer Z secondary waveform extension control bit (b3) of PUM to "1". As a result, the waveforms of more accurate resolution can be output.

When b2 and b3 of PUM are used, the frequency and duty of the output waveform are as follows;

Waveform frequency:

$$FTZOUT = (2 \times TMCL) / (2 \times (TZP + 1) + 2 \times (TZS) + (EXPZP + EXPZS))$$

Duty:

$$DTZOUT = (2 \times (TZP + 1) + EXPZP) / (2 \times (TZS + 1) + EXPZS)$$

TMCL: Timer Z count clock $f(X_{IN})/2$ or $f(X_{IN})/16$

TZP: Timer Z primary latch (8 bits)

TZS: Timer Z secondary latch (8 bits)

EXPZP: Timer Z primary waveform extension control bit (1 bit)

EXPZS: Timer Z secondary waveform extension control bit (1 bit)

When using the programmable waveform generation mode, note the following;

Notes on using the programmable waveform generation mode

- When setting and changing TZP, TZS, EXPZP and EXPZS, write to TZP at last because the setting to them is executed all at once by writing to TZP. Even when TZP is not changed, write the same value. The value is reloaded to timer at the beginning of the next primary interval.
- Set by software in order not to execute the writing to timer Z primary and the timing of timer underflow simultaneously. When reading the timer Z secondary, the undefined value is read out. However, while timer counts the setting value of the timer Z secondary, the count values at the secondary interval can be identified by reading the timer Z primary.
- In this mode, set port P0₂ which is also used as TZOUT pin to output.
- B2 and b3 of PUM can be used only when "0016" is set to prescaler Z and $f(X_{IN})/2$ or $f(X_{IN})/16$ is selected as the timer Z count source.

PRELIMINARY
 Notice: This is not a final specification.
 Some parametric limits are subject to change.

(3) Programmable one-shot generation mode

- Mode select

Timer mode is selected by setting timer Z operation mode bits (b5,b4) of TYZM to "10".

When this mode is selected, set timer Z write control bit (b6) of TYZM to "1" ("writing to only latch" selected).

- Count source select

The count source is $f(X_{IN})/2$, $f(X_{IN})/16$ or timer Y underflow.

- Interrupt

When an underflow occurs, timer Z interrupt request bit (b1) of IREQ2 is set to "1".

- Operation description

After reset release, timer Z is operating because the timer Z count stop bit (b7) of TYZM is "0". MCU operates in the programmable one-shot generation mode when timer Z operation mode bits (b5, b4) of TYZM is set to "10" after timer Z operation is stopped by setting b7 of TYZM to "1".

Timer Z is enabled to accept the one-shot start trigger when "0" is written to b7 of TYZM after the timer count value is set to the timer Z primary latch (TZP). In this state, when "1" is written to the timer Z one-shot start bit (b0) of the one-shot start register (ONS), timer Z starts count operation, at the same time, the output of TZOUT pin is inverted. Timer Z counts down the value of TZP and stops after the output of TZOUT pin is inverted to the same level as the initial state when an underflow occurs. In this time, the next one-shot pulse can be output by writing b0 of ONS to "1" because this bit is initialized to "0".

The active edge of the output waveform from TZOUT pin is set by the timer Z output level latch (b5) of PUM. When "0" is set to b5 of PUM, the initial level of timer at stop is "L" and "H" is output at the same time when timer starts. "H" is output in the count interval of TZP, and the output is inverted to "L" and stopped when an underflow occurs.

Also, when "1" is set to b5 of PUM, the initial level of timer at stop is "H" and "L" is output at the same time when timer starts. "L" is output in the count interval of TZP, and the output is inverted to "H" and stopped when an underflow occurs.

When the INTO pin one-shot trigger control bit (b6) of PUM is set to "1", the one-shot pulse can be output by using the input of INTO pin as a trigger. The active edge of the pulse input to INTO pin as the trigger can be selected by the INTO pin one-shot trigger active edge selection bit (b7) of PUM. The trigger is accepted and the one-shot pulse is generated by the falling edge of INTO pin input when "0" is set to b7 of PUM or the rising edge of INTO pin input when "1" is set to the b7 of PUM.

Also, the INTO interrupt occurs when the trigger is input from the INTO pin by setting the INTO interrupt edge selection bit (b0) of the interrupt edge selection register (INTEDGE) and the INTO interrupt enable bit (b2) of the interrupt control register 1 (ICON1). Even when the trigger by the INTO pin input is selected, the one-shot pulse can be output by writing to b0 of ONS.

Also, in this mode, the waveform output interval of the one-shot pulse can be extended for 0.5 cycle of timer count source clock by setting the timer Z primary waveform extension control bit (b2) to "1". As a result, the waveforms of more accurate resolution can be output.

When using the programmable one-shot generation mode, note the following;

Notes on using the programmable one-shot generation mode

- When setting and changing TZP and EXPZS, write to TZP at last because the setting to them is executed all at once by writing to TZP. Even when TZP is not changed, write the same value. The value is reloaded to timer at the beginning of the next primary interval.
- Set by software in order not to execute the writing to timer Z primary and the timing of timer underflow simultaneously. When reading the timer Z secondary, the undefined value is read out. However, while timer counts the setting value of the timer Z secondary, the count values at the secondary interval can be identified by reading the timer Z primary.
- In this mode, set port P02 which is also used as TZOUT pin to output.
- B2 of PUM can be used only when "0016" is set to prescaler Z and $f(X_{IN})/2$ or $f(X_{IN})/16$ is selected as the timer Z count source.

PRELIMINARY
 Notice: This is not a final specification.
 Some parametric limits are subject to change.

(4) Programmable wait one-shot generation mode

• Mode select

Timer mode is selected by setting timer Z operation mode bits (b5,b4) of TYZM to "11".

When this mode is selected, set timer Z write control bit (b6) of TYZM to "1" ("writing to only latch" selected).

• Count source select

The count source is $f(X_{IN})/2$, $f(X_{IN})/16$ or timer Y underflow.

• Interrupt

When an underflow occurs, timer Z interrupt request bit (b1) of IREQ is set to "1".

• Operation description

After reset release, timer Z is operating because the timer Z count stop bit (b7) of TYZM is "0". MCU operates in the programmable wait one-shot generation mode when timer Z operation mode bits (b5, b4) of TYZM is set to "11" after timer Z operation is stopped by setting b7 of TYZM to "1".

Timer Z is enabled to accept the one-shot start trigger when "0" is written to b7 of TYZM after the timer count values are set to the timer Z primary latch (TZP) and the timer Z secondary latch (TZS). In this state, when "1" is written to the timer Z one-shot start bit (b0) of ONS, timer Z starts count operation. Unlike the programmable one-shot generation mode, the output of TZOUT pin is not changed until the timer counts TZP and an underflow occurs.

When the timer Z counts TZP and an underflow occurs, TZS is reloaded to timer, at the same time, the output of the TZOUT pin is inverted.

Timer Z counts down the value of TZP and stops after the output of TZOUT pin is inverted to the same level as the initial state when an underflow occurs. In this time, the next one-shot pulse can be output by writing b0 of ONS to "1" because this bit is initialized to "0".

The active edge of the output waveform from TZOUT pin is set by the timer Z output level latch (b5) of PUM. When "0" is set to b5 of PUM, the initial level of timer at stop and the TZP count interval are "L" and inverted to "H" at the same time when an underflow occurs. "H" is output in the count interval of TZS, and the output is inverted to "L" and stopped when an underflow occurs.

Also, when "1" is set to b5 of PUM, the initial level of timer at stop and the TZP count interval are "H" and inverted to "L" at the same time when an underflow occurs. "L" is output in the count interval of TZS, and the output is inverted to "H" and stopped when an underflow occurs.

When the INT0 pin one-shot trigger control bit (b6) of PUM is set to "1", the one-shot pulse can be output by using the input of INT0 pin as a trigger. The active edge of the pulse input to INT0 pin as the trigger can be selected by the INT0 pin one-shot trigger active edge selection bit (b7) of PUM. The trigger is accepted and the one-shot pulse is generated by the falling edge of INT0 pin input when "0" is set to b7 of PUM or the rising edge of INT0 pin input when "1" is set to the b7 of PUM.

Also, the INT0 interrupt occurs when the trigger is input from the INT0 pin by setting the INT0 interrupt edge selection bit (b0) of the interrupt edge selection register (INTEDGE) and the INT0 interrupt enable bit (b2) of the interrupt control register 1 (ICON1). Even when the trigger by the INT0 pin input is selected, the one-shot pulse can be output by writing to b0 of ONS.

Also, in this mode, the waveform output interval of the one-shot pulse can be extended for 0.5 cycle of timer count source clock by setting the timer Z primary waveform extension control bit (b2) to "1". As a result, the waveforms of more accurate resolution can be output.

When using the programmable wait one-shot generation mode, note the following;

Notes on using the programmable wait one-shot generation mode

- When setting and changing TZP, TZS, EXPZP and EXPZS, write to TZP at last because the setting to them is executed all at once by writing to TZP. Even when TZP is not changed, write the same value. The value is reloaded to timer at the beginning of the next primary interval.
- Set by software in order not to execute the writing to timer Z primary and the timing of timer underflow simultaneously. When reading the timer Z secondary, the undefined value is read out. However, while timer counts the setting value of the timer Z secondary, the count values at the secondary interval can be identified by reading the timer Z primary.
- In this mode, set port P02 which is also used as TZOUT pin to output.
- B2 of PUM can be used only when "0016" is set to prescaler Z and $f(X_{IN})/2$ or $f(X_{IN})/16$ is selected as the timer Z count source.

PRELIMINARY
 Notice: This is not a final specification.
 Some parametric limits are subject to change.

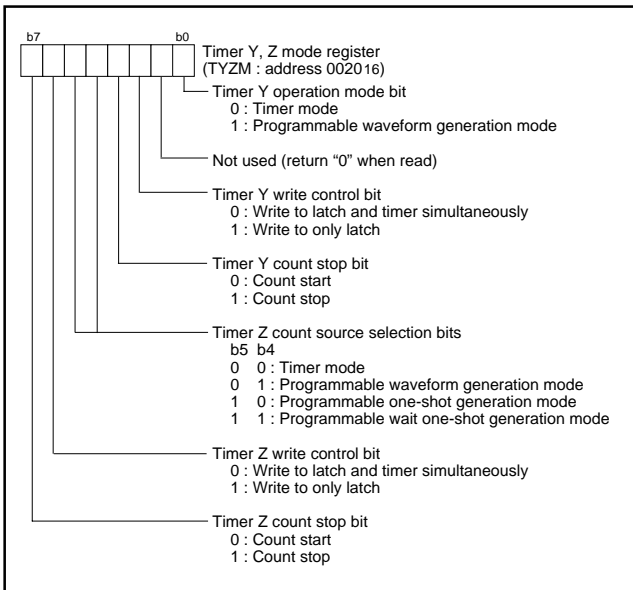

Fig. 22 Structure of timer Y, Z mode register

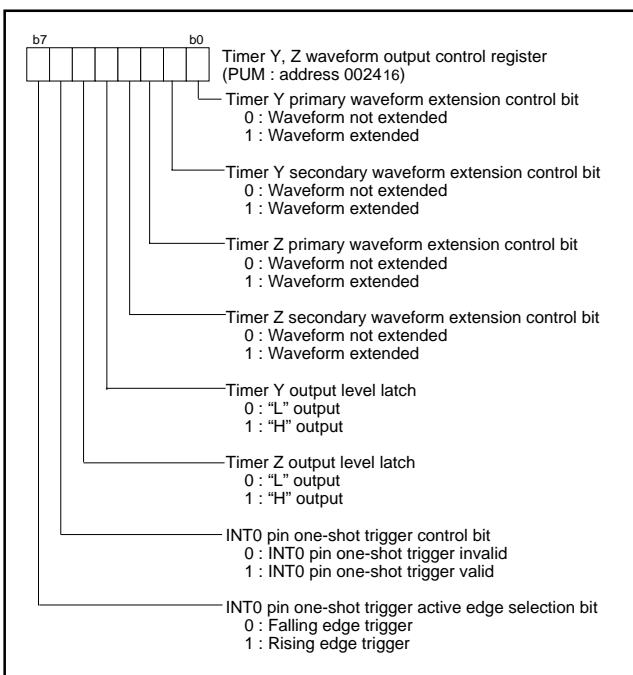

Fig. 23 Structure of timer YZ waveform output control register

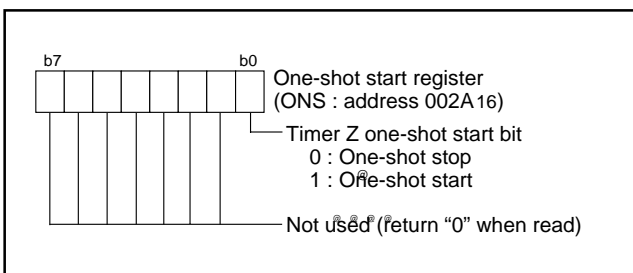

Fig. 24 Structure of one-shot start register

PRELIMINARY
 Notice: This is not a final specification.
 Some parametric limits are subject to change.

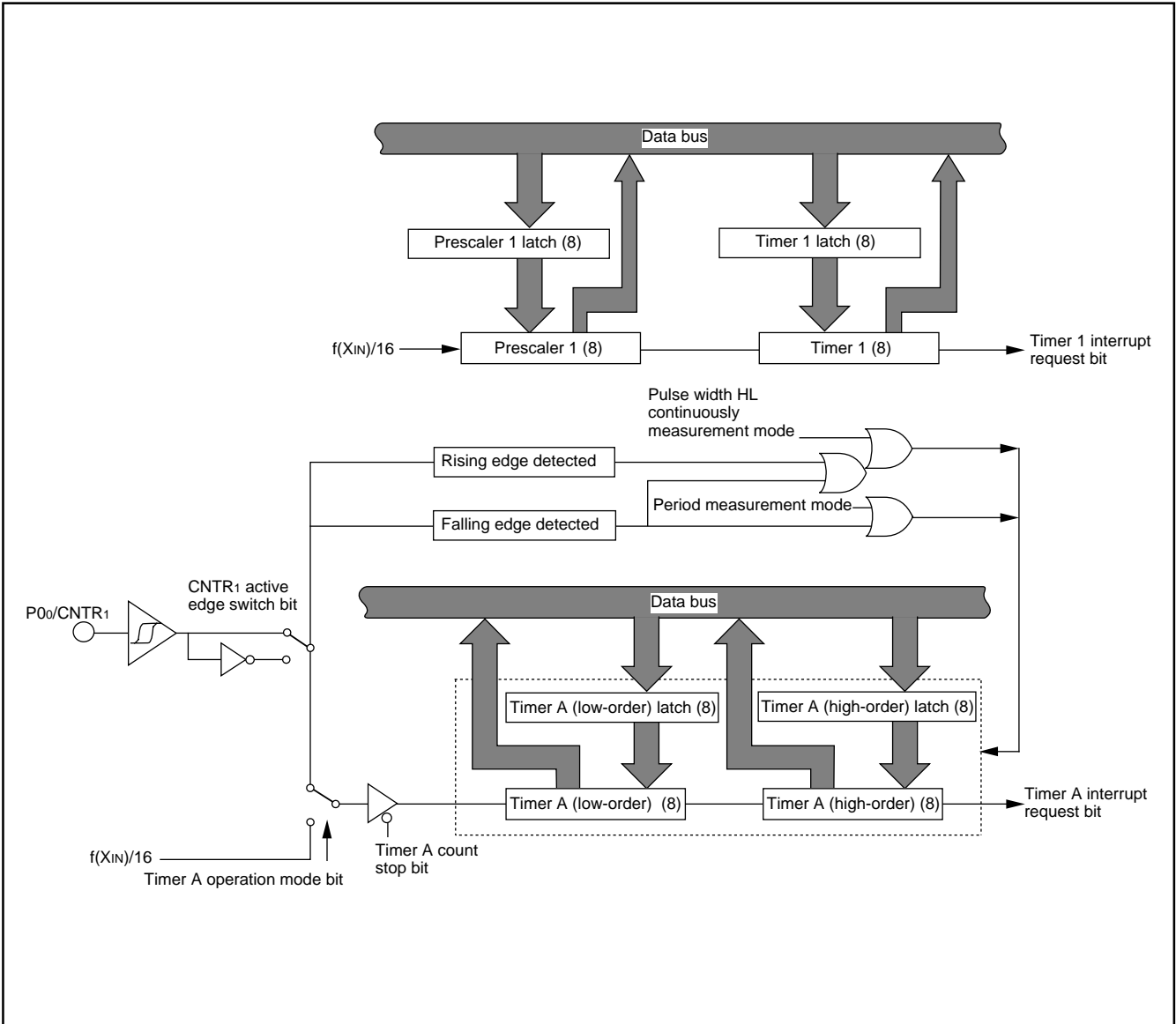

Fig. 25 Block diagram of timer 1 and timer A

PRELIMINARY
 Notice: This is not a final specification.
 Some parametric limits are subject to change.

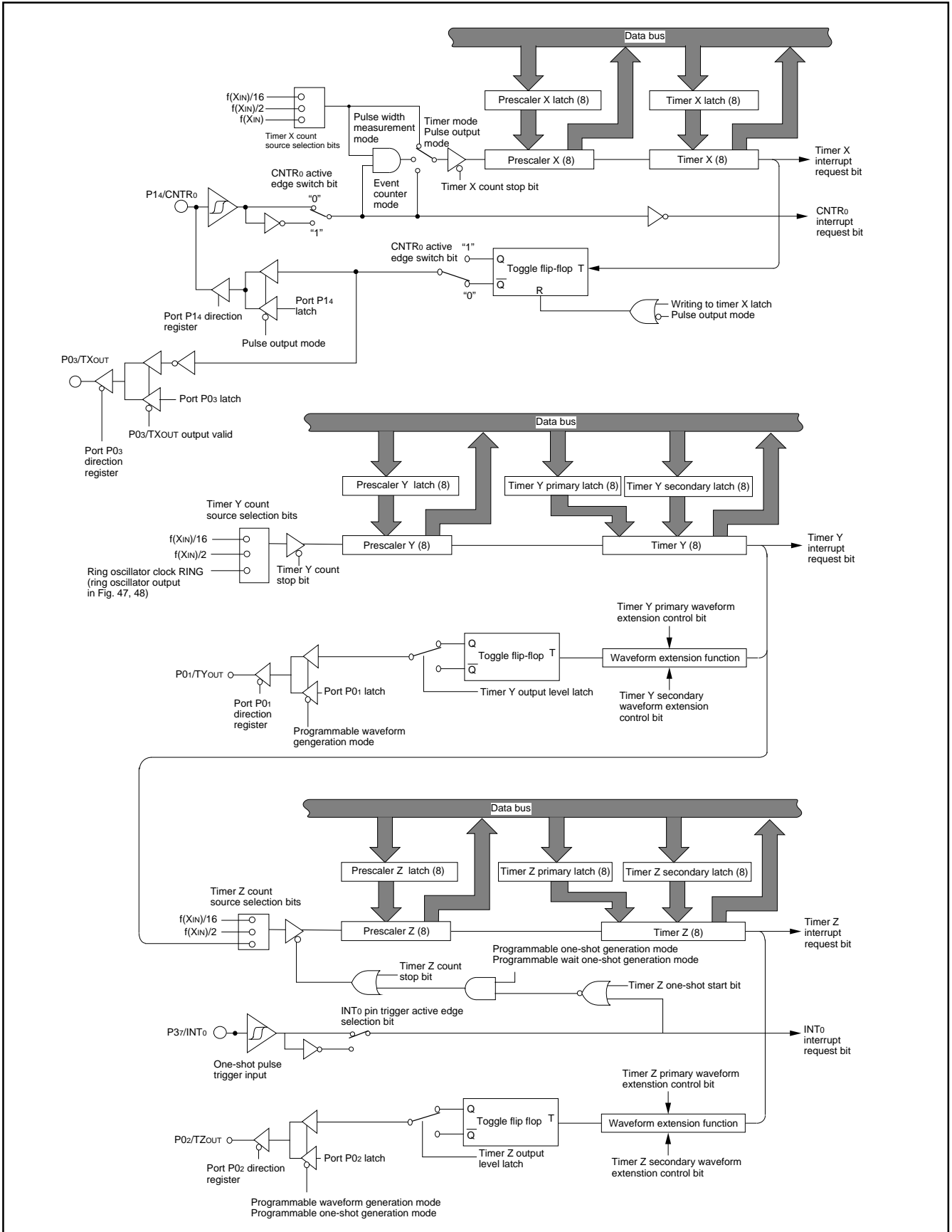

Fig. 26 Block diagram of timer X, timer Y and timer Z

PRELIMINARY
 Notice: This is not a final specification.
 Some parametric limits are subject to change.

Serial I/O

Serial I/O1

Serial I/O1 can be used as either clock synchronous or asynchronous (UART) serial I/O. A dedicated timer is also provided for baud rate generation.

(1) Clock Synchronous Serial I/O Mode

Clock synchronous serial I/O1 mode can be selected by setting the serial I/O1 mode selection bit of the serial I/O1 control register (bit 6) to "1".

For clock synchronous serial I/O 1, the transmitter and the receiver must use the same clock. If an internal clock is used, transfer is started by a write signal to the TB/RB.

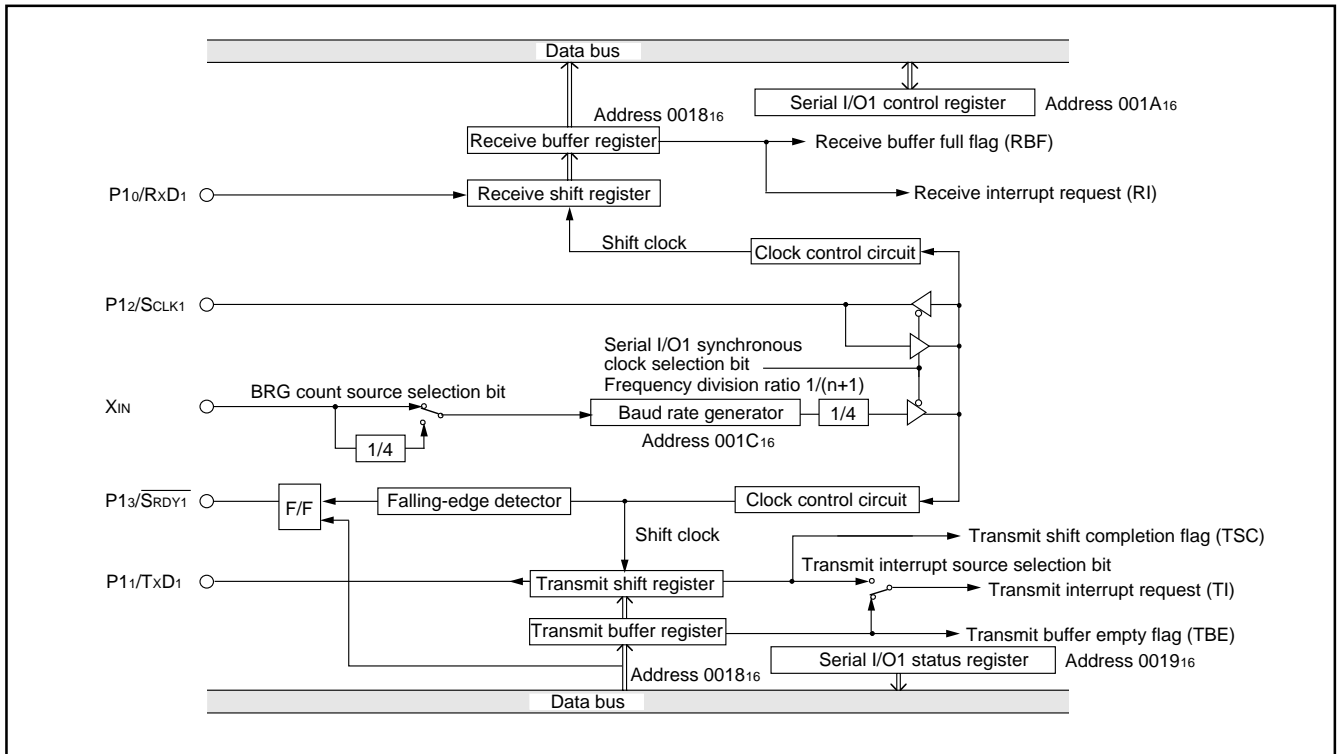

Fig. 27 Block diagram of clock synchronous serial I/O1

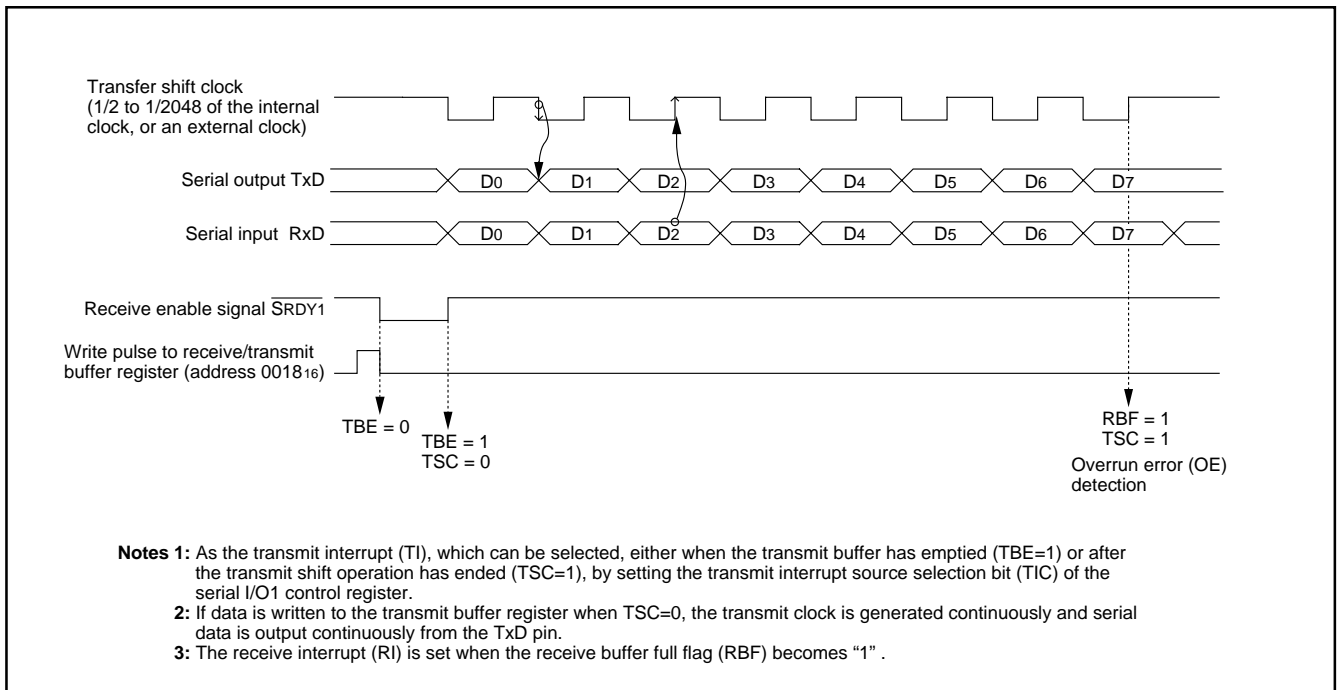

Fig. 28 Operation of clock synchronous serial I/O1 function

(2) Asynchronous Serial I/O (UART) Mode

Clock asynchronous serial I/O mode (UART) can be selected by clearing the serial I/O1 mode selection bit of the serial I/O1 control register to "0".

Eight serial data transfer formats can be selected, and the transfer formats used by a transmitter and receiver must be identical.

The transmit and receive shift registers each have a buffer, but the two buffers have the same address in memory. Since the shift register cannot be written to or read from directly, transmit data is written to the transmit buffer register, and receive data is read from the receive buffer register.

The transmit buffer register can also hold the next data to be transmitted, and the receive buffer register can hold a character while the next character is being received.

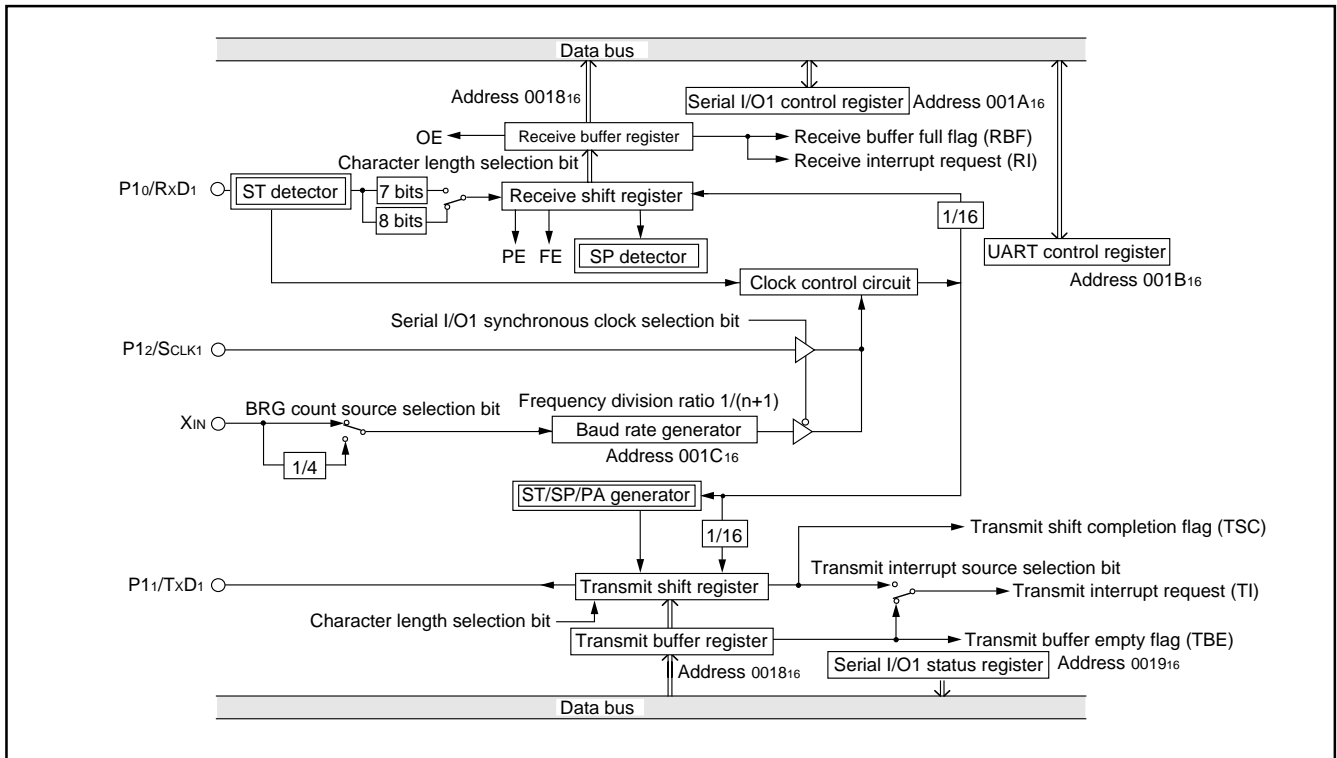

Fig. 29 Block diagram of UART serial I/O1

PRELIMINARY
 Notice: This is not a final specification.
 Some parametric limits are subject to change.

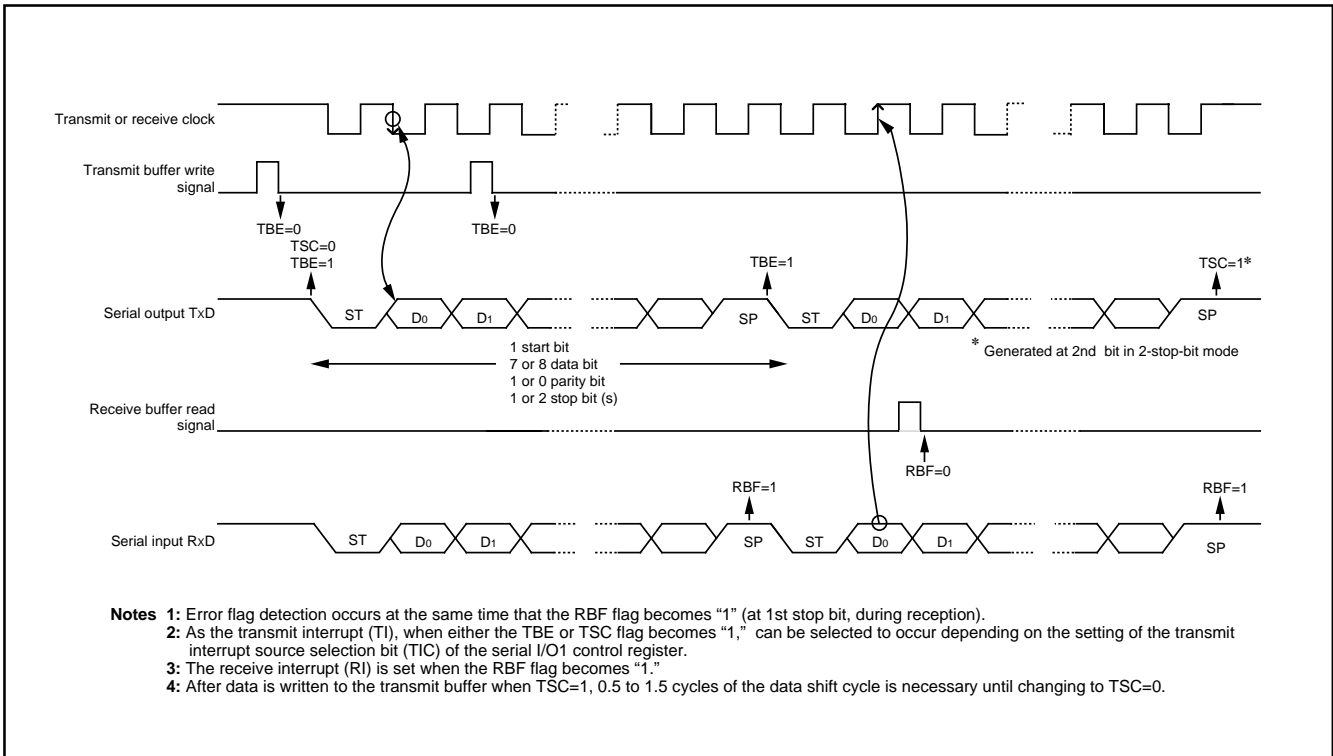

Fig. 30 Operation of UART serial I/O1 function

[Transmit buffer register/receive buffer register (TB/RB)] 0018₁₆

The transmit buffer register and the receive buffer register are located at the same address. The transmit buffer is write-only and the receive buffer is read-only. If a character bit length is 7 bits, the MSB of data stored in the receive buffer is "0".

[Serial I/O1 status register (SIO1STS)] 0019₁₆

The read-only serial I/O1 status register consists of seven flags (bits 0 to 6) which indicate the operating status of the serial I/O1 function and various errors.

Three of the flags (bits 4 to 6) are valid only in UART mode.

The receive buffer full flag (bit 1) is cleared to "0" when the receive buffer register is read.

If there is an error, it is detected at the same time that data is transferred from the receive shift register to the receive buffer register, and the receive buffer full flag is set. A write to the serial I/O1 status register clears all the error flags OE, PE, FE, and SE (bit 3 to bit 6, respectively). Writing "0" to the serial I/O1 enable bit SIOE (bit 7 of the serial I/O1 control register) also clears all the status flags, including the error flags.

All bits of the serial I/O1 status register are initialized to "0" at reset, but if the transmit enable bit (bit 4) of the serial I/O1 control register has been set to "1", the transmit shift completion flag (bit 2) and the transmit buffer empty flag (bit 0) become "1".

[Serial I/O1 control register (SIO1CON)] 001A₁₆

The serial I/O1 control register consists of eight control bits for the serial I/O1 function.

[UART control register (UARTCON)] 001B₁₆

The UART control register consists of four control bits (bits 0 to 3) which are valid when asynchronous serial I/O is selected and set the data format of an data transfer and one bit (bit 4) which is always valid and sets the output structure of the P11/TXD1, P12/SCLK1 pin.

[Baud rate generator (BRG)] 001C₁₆

The baud rate generator determines the baud rate for serial transfer.

The baud rate generator divides the frequency of the count source by $1/(n + 1)$, where n is the value written to the baud rate generator.

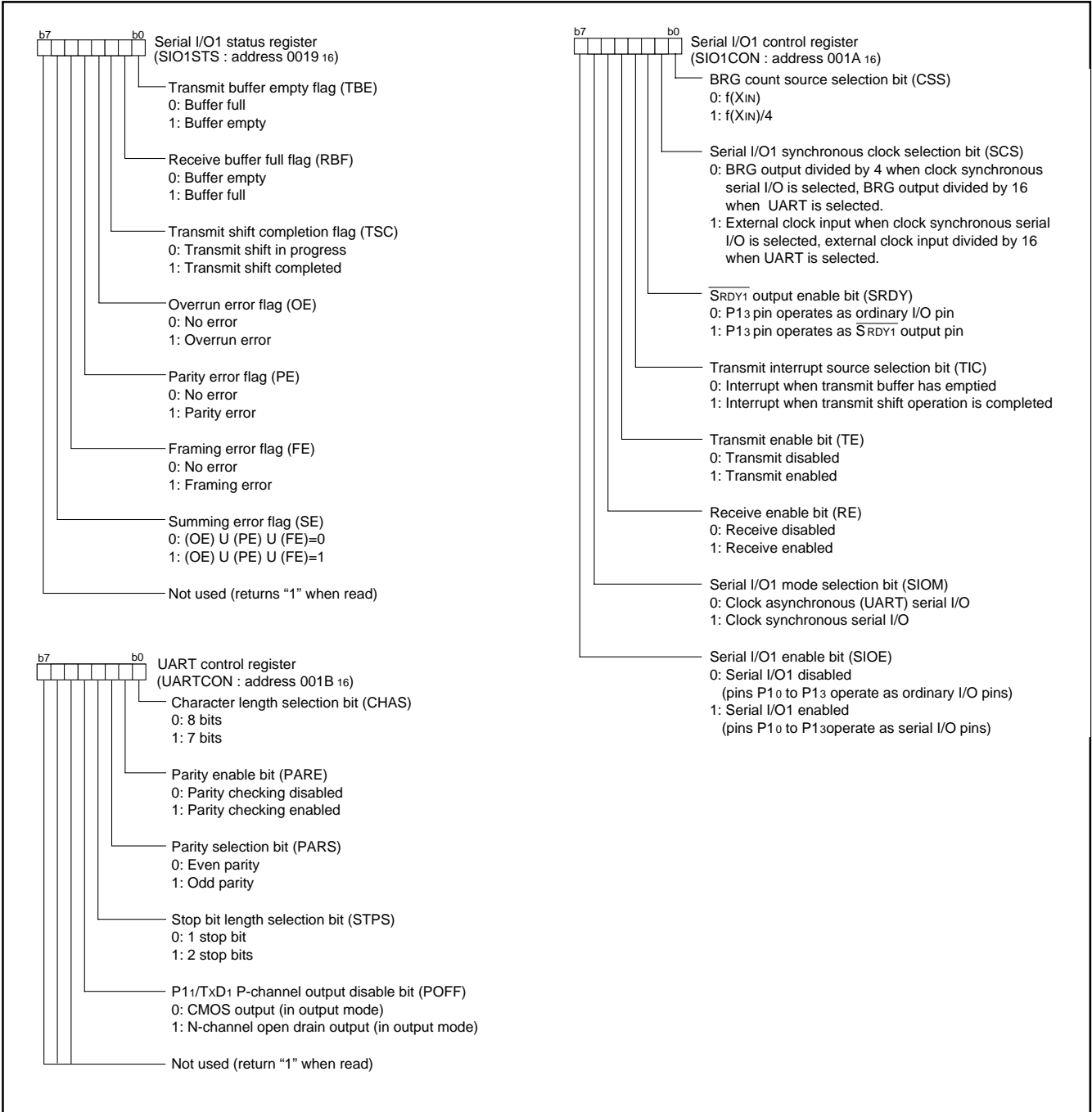

Fig. 31 Structure of serial I/O1-related registers

PRELIMINARY
 Notice: This is not a final specification.
 Some parametric limits are subject to change.

Serial I/O2

The serial I/O2 function can be used only for clock synchronous serial I/O.

For clock synchronous serial I/O2 the transmitter and the receiver must use the same clock. When the internal clock is used, transfer is started by a write signal to the serial I/O2 register.

Note: Serial I/O2 can be used in the following cases;

- (1) Serial I/O1 is not used,
- (2) Serial I/O1 is used as UART and BRG output divided by 16 is selected as the synchronized clock.

[Serial I/O2 control register] SIO2CON

The serial I/O2 control register contains 8 bits which control various serial I/O functions.

- Set "0" to bit 3 to receive.
- At reception, clear bit 7 to "0" by writing a dummy data to the serial I/O2 register after completion of shift.

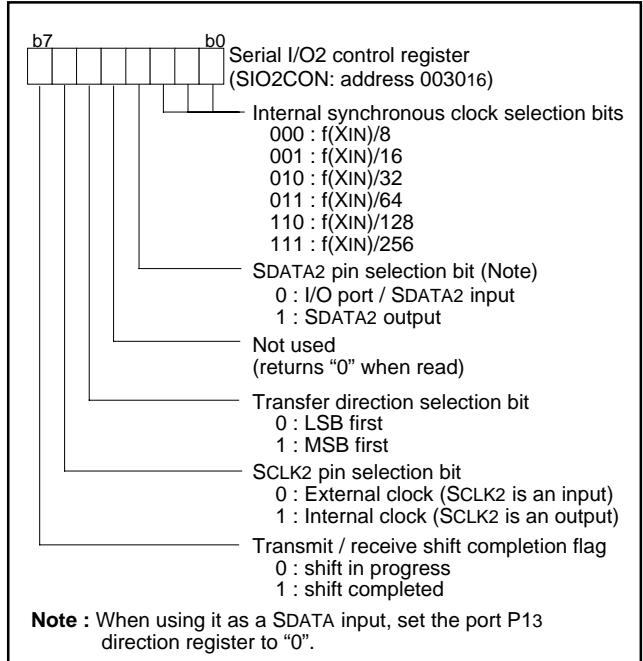

Fig. 32 Structure of serial I/O2 control registers

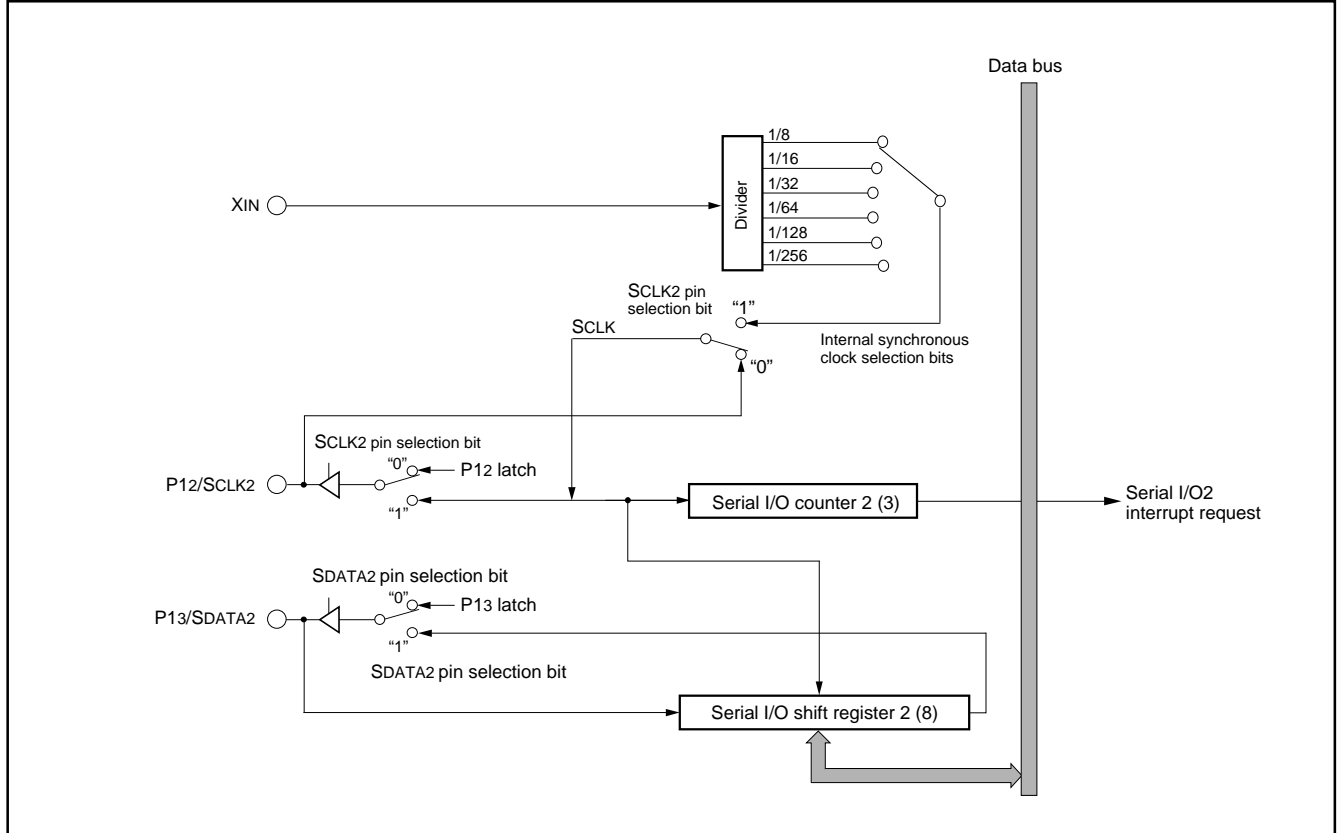

Fig. 33 Block diagram of serial I/O2

PRELIMINARY
 Notice: This is not a final specification.
 Some parametric limits are subject to change.

Serial I/O2 operation

By writing to the serial I/O2 register (address 003116) the serial I/O2 counter is set to "7".

After writing, the SDATA2 pin outputs data every time the transfer clock shifts from "H" to "L". And, as the transfer clock shifts from "L" to "H", the SDATA2 pin reads data, and at the same time the contents of the serial I/O2 register are shifted by 1 bit.

When the internal clock is selected as the transfer clock source, the following operations execute as the transfer clock counts up to 8.

- Serial I/O2 counter is cleared to "0".
- Transfer clock stops at an "H" level.
- Interrupt request bit is set.
- Shift completion flag is set.

Also, the SDATA2 pin is in a high impedance state after the data transfer is completed.

When the external clock is selected as the transfer clock source, the interrupt request bit is set as the transfer clock counts up to 8, but external control of the clock is required since it does not stop. Notice that the SDATA2 pin is not in a high impedance state on the completion of data transfer.

Also, after the receive operation is completed, the transmit/receive shift completion flag is cleared by reading the serial I/O2 register. At transmit, the transmit/receive shift completion flag is cleared and the transmit operation is started by writing to serial I/O2 register.

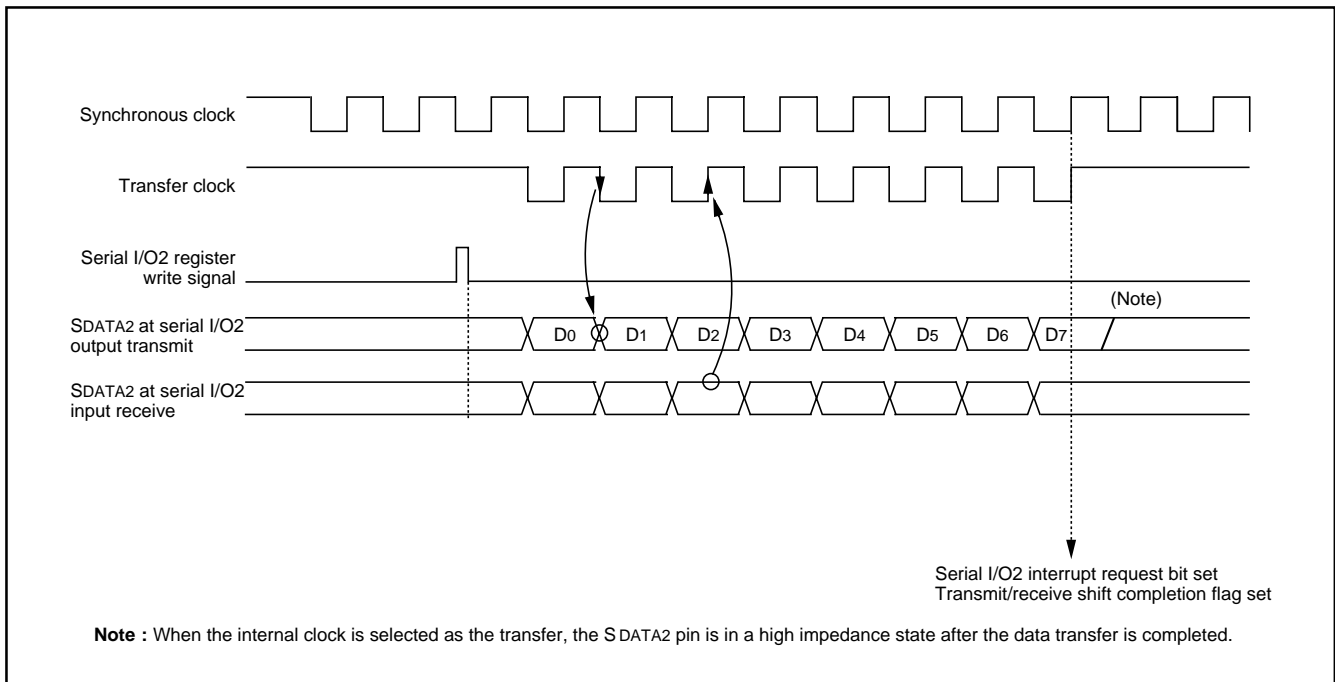

Fig. 34 Serial I/O2 timing (LSB first)

PRELIMINARY
 Notice: This is not a final specification.
 Some parametric limits are subject to change.

A-D Converter

The functional blocks of the A-D converter are described below.

[A-D conversion register] AD

The A-D conversion register is a read-only register that stores the result of A-D conversion. Do not read out this register during an A-D conversion.

[A-D control register] ADCON

The A-D control register controls the A-D converter. Bit 2 to 0 are analog input pin selection bits. Bit 4 is the AD conversion completion bit. The value of this bit remains at "0" during A-D conversion, and changes to "1" at completion of A-D conversion.

A-D conversion is started by setting this bit to "0".

[Comparison voltage generator]

The comparison voltage generator divides the voltage between AVSS and VREF by 1024, and outputs the divided voltages.

[Channel selector]

The channel selector selects one of ports P27/AN7 to P20/AN0, and inputs the voltage to the comparator.

[Comparator and control circuit]

The comparator and control circuit compares an analog input voltage with the comparison voltage and stores its result into the A-D conversion register. When A-D conversion is completed, the control circuit sets the AD conversion completion bit and the AD interrupt request bit to "1". Because the comparator is constructed linked to a capacitor, set f(XIN) to 500 kHz or more during A-D conversion.

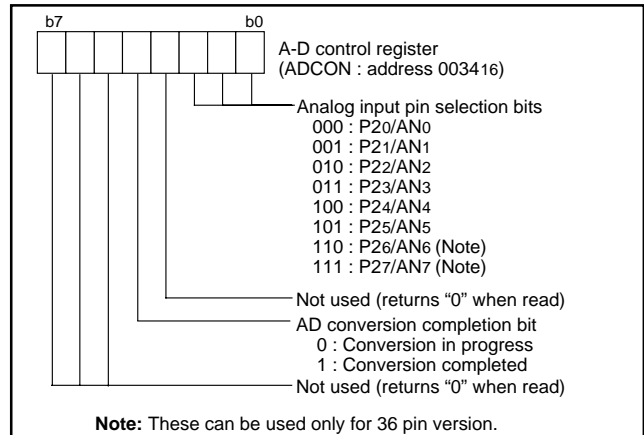

Fig. 35 Structure of A-D control register

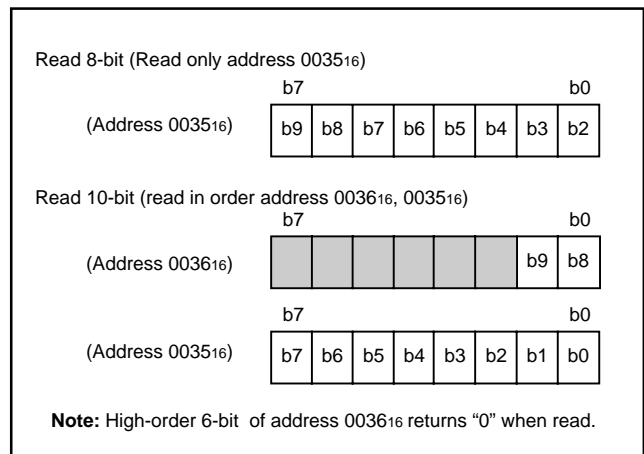

Fig. 36 Structure of A-D conversion register

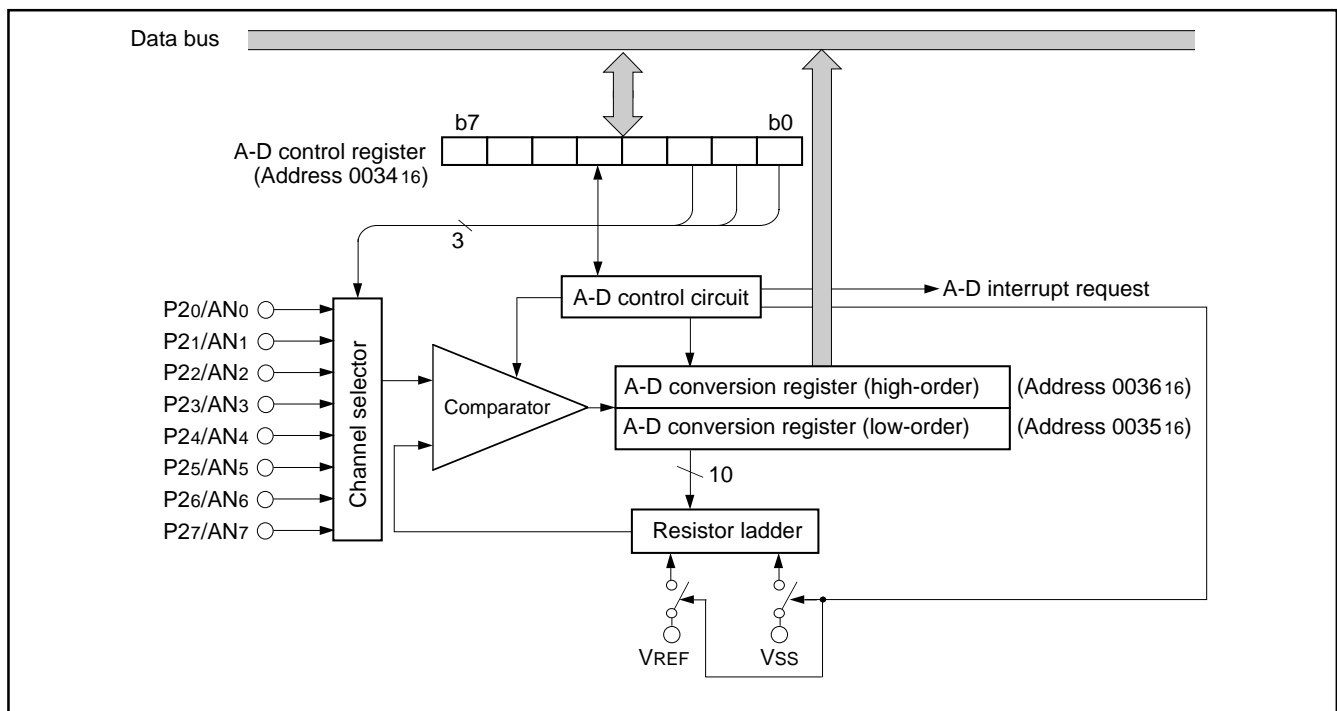

Fig. 37 Block diagram of A-D converter

PRELIMINARY
 Notice: This is not a final specification.
 Some parametric limits are subject to change.

Watchdog Timer

The watchdog timer gives a means for returning to a reset status when the program fails to run on its normal loop due to a runaway. The watchdog timer consists of an 8-bit watchdog timer H and an 8-bit watchdog timer L, being a 16-bit counter.

Standard operation of watchdog timer

The watchdog timer stops when the watchdog timer control register (address 0039₁₆) is not set after reset. Writing an optional value to the watchdog timer control register (address 0039₁₆) causes the watchdog timer to start to count down. When the watchdog timer H underflows, an internal reset occurs. Accordingly, it is programmed that the watchdog timer control register (address 0039₁₆) can be set before an underflow occurs.

When the watchdog timer control register (address 0039₁₆) is read, the values of the high-order 6-bit of the watchdog timer H, STP instruction disable bit and watchdog timer H count source selection bit are read.

Initial value of watchdog timer

By a reset or writing to the watchdog timer control register (address 0039₁₆), the watchdog timer H is set to "FF₁₆" and the watchdog timer L is set to "FF₁₆".

Operation of watchdog timer H count source selection bit

A watchdog timer H count source can be selected by bit 7 of the watchdog timer control register (address 0039₁₆). When this bit is "0", the count source becomes a watchdog timer L underflow signal. The detection time is 131.072 ms at f(XIN)=8 MHz. When this bit is "1", the count source becomes f(XIN)/16. In this case, the detection time is 512 μs at f(XIN)=8 MHz. This bit is cleared to "0" after reset.

Operation of STP instruction disable bit

When the watchdog timer is in operation, the STP instruction can be disabled by bit 6 of the watchdog timer control register (address 0039₁₆). When this bit is "0", the STP instruction is enabled. When this bit is "1", the STP instruction is disabled, and an internal reset occurs if the STP instruction is executed. Once this bit is set to "1", it cannot be changed to "0" by program. This bit is cleared to "0" after reset.

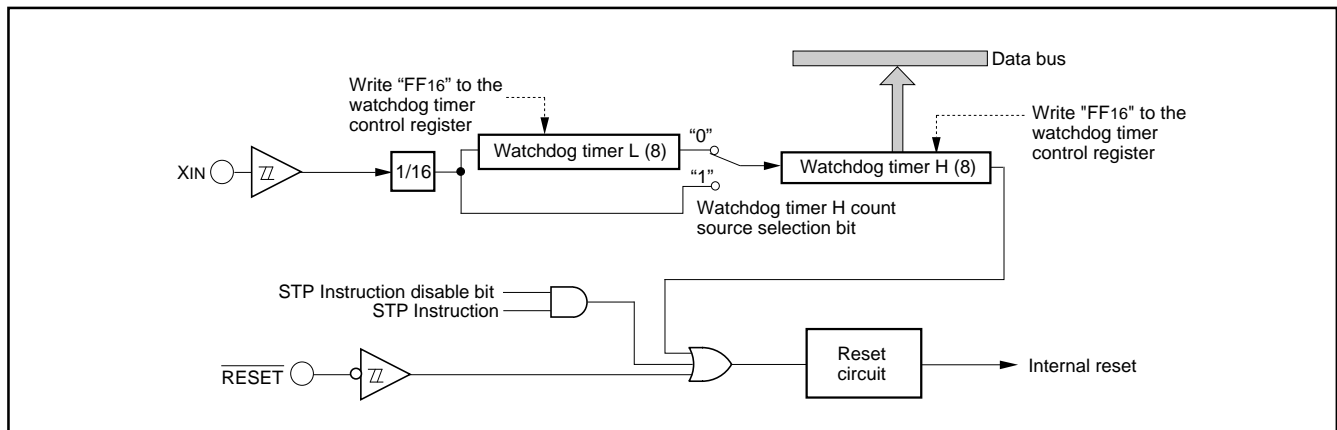

Fig. 38 Block diagram of watchdog timer

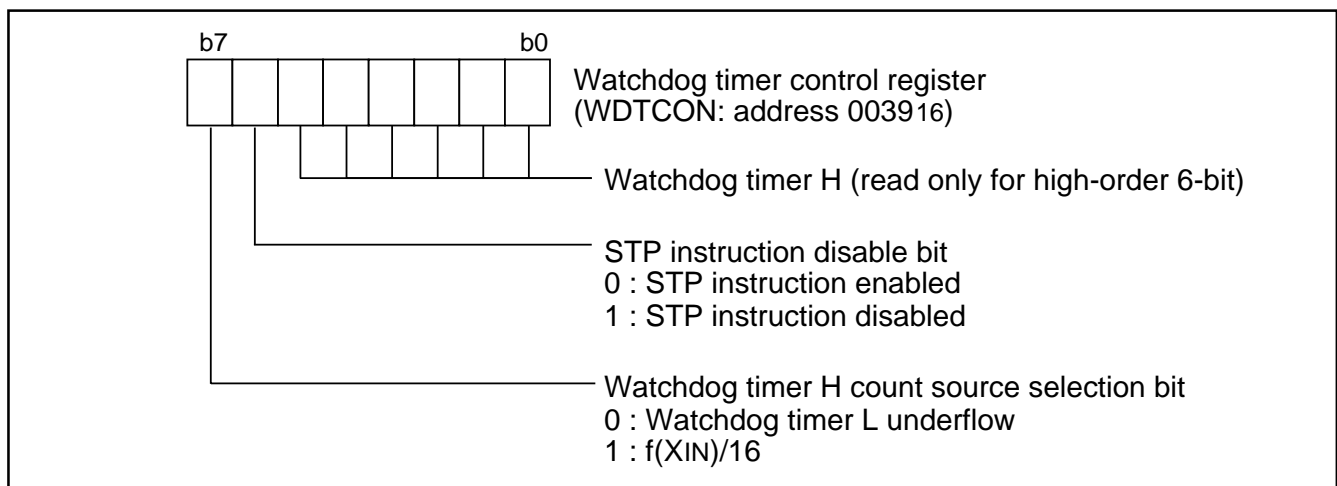

Fig. 39 Structure of watchdog timer control register

PRELIMINARY
 Notice: This is not a final specification.
 Some parametric limits are subject to change.

Reset Circuit

The microcomputer is put into a reset status by holding the $\overline{\text{RESET}}$ pin at the "L" level for 2 μs or more when the power source voltage is 2.2 to 5.5 V and X_{IN} is in stable oscillation.

After that, this reset status is released by returning the $\overline{\text{RESET}}$ pin to the "H" level. The program starts from the address having the contents of address FFFD_{16} as high-order address and the contents of address FFFC_{16} as low-order address.

In the case of $f(\phi) \leq 4 \text{ MHz}$, the reset input voltage must be 0.8 V or less when the power source voltage passes 4.0 V.

In the case of $f(\phi) \leq 2 \text{ MHz}$, the reset input voltage must be 0.48 V or less when the power source voltage passes 2.4 V.

In the case of $f(\phi) \leq 1 \text{ MHz}$, the reset input voltage must be 0.44 V or less when the power source voltage passes 2.2 V.

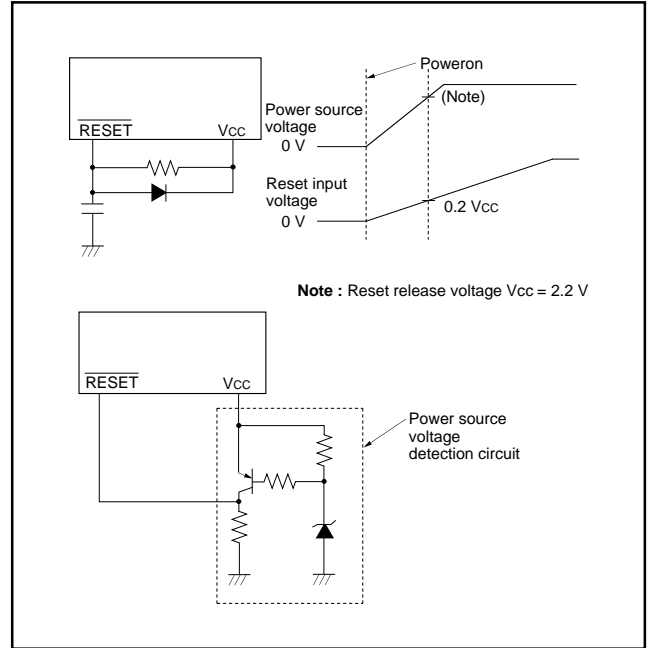

Fig. 40 Example of reset circuit

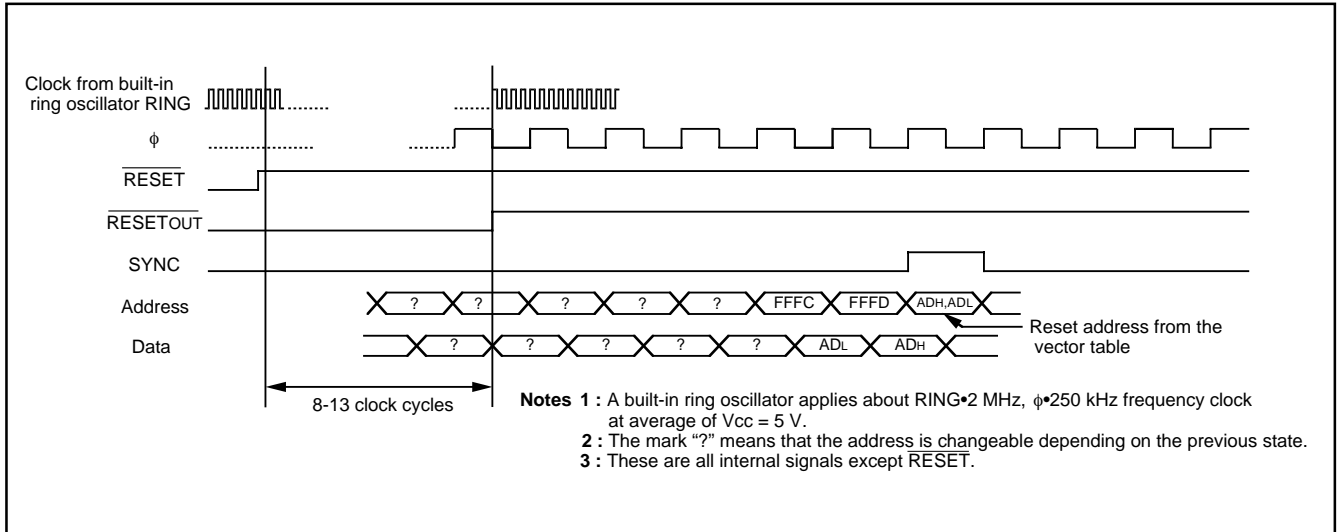

Fig. 41 Timing diagram at reset

PRELIMINARY
 Notice: This is not a final specification.
 Some parametric limits are subject to change.

	Address	Register contents
(1) Port P0 direction register	0001 ₁₆	00 ₁₆
(2) Port P1 direction register	0003 ₁₆	X X X 0 0 0 0 0
(3) Port P2 direction register	0005 ₁₆	00 ₁₆
(4) Port P3 direction register	0007 ₁₆	00 ₁₆
(5) Pull-up control register	0016 ₁₆	00 ₁₆
(6) Port P1P3 control register	0017 ₁₆	00 ₁₆
(7) Serial I/O1 status register	0019 ₁₆	1 0 0 0 0 0 0 1
(8) Serial I/O1 control register	001A ₁₆	02 ₁₆
(9) UART control register	001B ₁₆	1 1 1 0 0 0 0 0
(10) Timer A mode register	001D ₁₆	00 ₁₆
(11) Timer A (low-order)	001E ₁₆	FF ₁₆
(12) Timer A (high-order)	001F ₁₆	FF ₁₆
(13) Timer Y, Z mode register	0020 ₁₆	00 ₁₆
(14) Prescaler Y	0021 ₁₆	FF ₁₆
(15) Timer Y secondary	0022 ₁₆	FF ₁₆
(16) Timer Y primary	0023 ₁₆	FF ₁₆
(17) Timer Y, Z waveform output control register	0024 ₁₆	00 ₁₆
(18) Prescaler Z	0025 ₁₆	FF ₁₆
(19) Timer Z secondary	0026 ₁₆	FF ₁₆
(20) Timer Z primary	0027 ₁₆	FF ₁₆
(21) Prescaler 1	0028 ₁₆	FF ₁₆
(22) Timer 1	0029 ₁₆	01 ₁₆
(23) One-shot start register	002A ₁₆	00 ₁₆
(24) Timer X mode register	002B ₁₆	00 ₁₆
(25) Prescaler X	002C ₁₆	FF ₁₆
(26) Timer X	002D ₁₆	FF ₁₆
(27) Timer count source set register	002E ₁₆	00 ₁₆
(28) Serial I/O2 control register	0030 ₁₆	00 ₁₆
(29) Serial I/O2 register	0031 ₁₆	00 ₁₆
(30) A-D control register	0034 ₁₆	10 ₁₆
(31) MISRG	0038 ₁₆	00 ₁₆
(32) Watchdog timer control register	0039 ₁₆	0 0 1 1 1 1 1 1
(33) Interrupt edge selection register	003A ₁₆	00 ₁₆
(34) CPU mode register	003B ₁₆	1 0 0 0 0 0 0 0
(35) Interrupt request register 1	003C ₁₆	00 ₁₆
(36) Interrupt request register 2	003D ₁₆	00 ₁₆
(37) Interrupt control register 1	003E ₁₆	00 ₁₆
(38) Interrupt control register 2	003F ₁₆	00 ₁₆
(39) Processor status register	(PS)	X X X X X 1 X X
(40) Program counter	(PC _H)	Contents of address FFFD ₁₆
	(PC _L)	Contents of address FF _{FC} ₁₆

Note X : Undefined

Fig. 42 Internal status of microcomputer at reset

PRELIMINARY
 Notice: This is not a final specification.
 Some parametric limits are subject to change.

Clock Generating Circuit

An oscillation circuit can be formed by connecting a resonator between X_{IN} and X_{OUT} , and an RC oscillation circuit can be formed by connecting a resistor and a capacitor.

Use the circuit constants in accordance with the resonator manufacturer's recommended values. No external resistor is needed between X_{IN} and X_{OUT} since a feed-back resistor exists on-chip.

Set the constants of the resistor and capacitor when an RC oscillator is used, so that a frequency variation due to LSI variation and resistor and capacitor variations may not exceed the standard input frequency.

●Oscillation control

• Stop mode

When the STP instruction is executed, the internal clock f stops at an "H" level and the X_{IN} oscillator stops. At this time, timer 1 is set to "01₁₆" and prescaler 1 is set to "FF₁₆" when the oscillation stabilization time set bit after release of the STP instruction is "0". On the other hand, timer 1 and prescaler 1 are not set when the above bit is "1". Accordingly, set the wait time fit for the oscillation stabilization time of the oscillator to be used. $f(X_{IN})/16$ is forcibly connected to the input of prescaler 1. When an external interrupt is accepted, oscillation is restarted but the internal clock f remains at "H" until timer 1 underflows. As soon as timer 1 underflows, the internal clock f is supplied. This is because when a ceramic oscillator is used, some time is required until a start of oscillation. In case oscillation is restarted by reset, no wait time is generated. So apply an "L" level to the \overline{RESET} pin while oscillation becomes stable.

Also, the STP instruction cannot be used while CPU is operating by a ring oscillator.

• Wait mode

If the WIT instruction is executed, the internal clock f stops at an "H" level, but the oscillator does not stop. The internal clock restarts if a reset occurs or when an interrupt is received. Since the oscillator does not stop, normal operation can be started immediately after the clock is restarted. To ensure that interrupts will be received to release the STP or WIT state, interrupt enable bits must be set to "1" before the STP or WIT instruction is executed.

When the STP status is released, prescaler 1 and timer 1 will start counting clock which is X_{IN} divided by 16, so set the timer 1 interrupt enable bit to "0" before the STP instruction is executed.

Note

For use with the oscillation stabilization set bit after release of the STP instruction set to "1", set values in timer 1 and prescaler 1 after fully appreciating the oscillation stabilization time of the oscillator to be used.

●Switch of ceramic and RC oscillations

After releasing reset the operation starts by starting a built-in ring oscillator. Then, a ceramic oscillation or an RC oscillation is selected by setting bit 5 of the CPU mode register.

●Double-speed mode

When a ceramic oscillation is selected, a double-speed mode can be used. Do not use it when an RC oscillation is selected.

●CPU mode register

Bits 5, 1 and 0 of CPU mode register are used to select oscillation mode and to control operation modes of the microcomputer. In order to prevent the dead-lock by error-writing (ex. program run-away), these bits can be rewritten only once after releasing reset. After rewriting it is disable to write any data to the bit. (The emulator MCU "M37540RSS" is excluded.)

Also, when the read-modify-write instructions (SEB, CLB) are executed to bits 2 to 4, 6 and 7, bits 5, 1 and 0 are locked.

●Clock division ratio, X_{IN} oscillation control, ring oscillator control

The state transition shown in Fig. 49 can be performed by setting the clock division ratio selection bits (bits 7 and 6), X_{IN} oscillation control bit (bit 4), ring oscillator oscillation control bit (bit 3) of CPU mode register. Be careful of notes on use in Fig. 49.

PRELIMINARY
 Notice: This is not a final specification.
 Some parametric limits are subject to change.

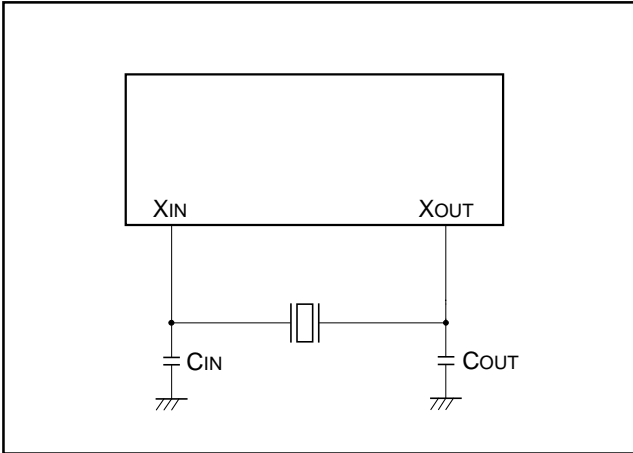

Fig. 43 External circuit of ceramic resonator

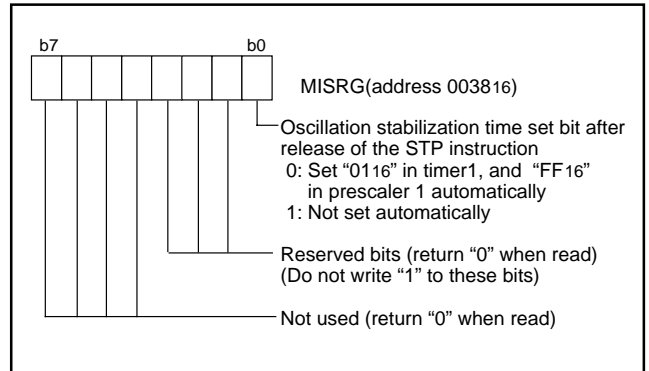

Fig. 46 Structure of MISRG

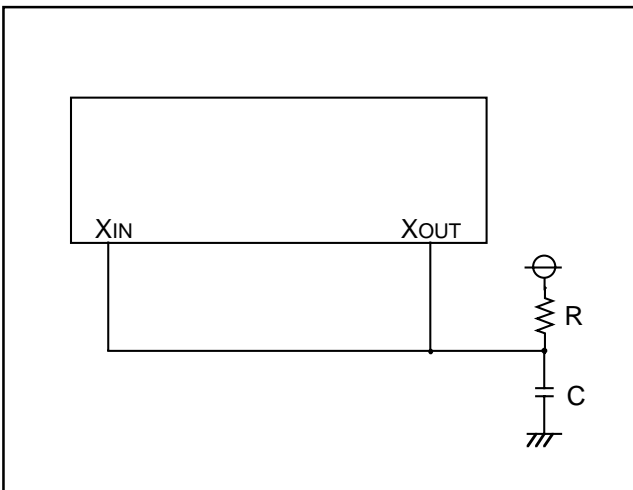

Fig. 44 External circuit of RC oscillation

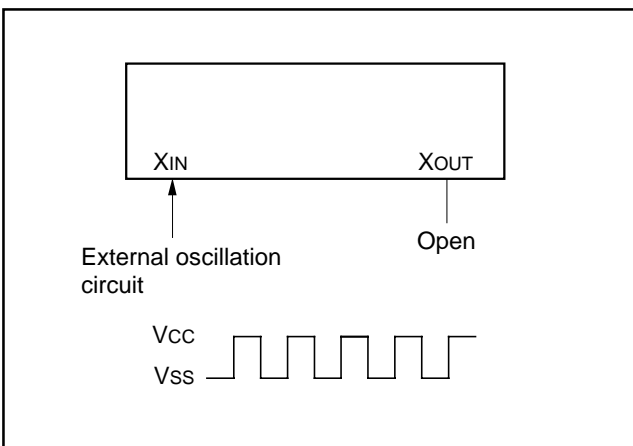

Fig. 45 External clock input circuit

PRELIMINARY
 Notice: This is not a final specification.
 Some parametric limits are subject to change.

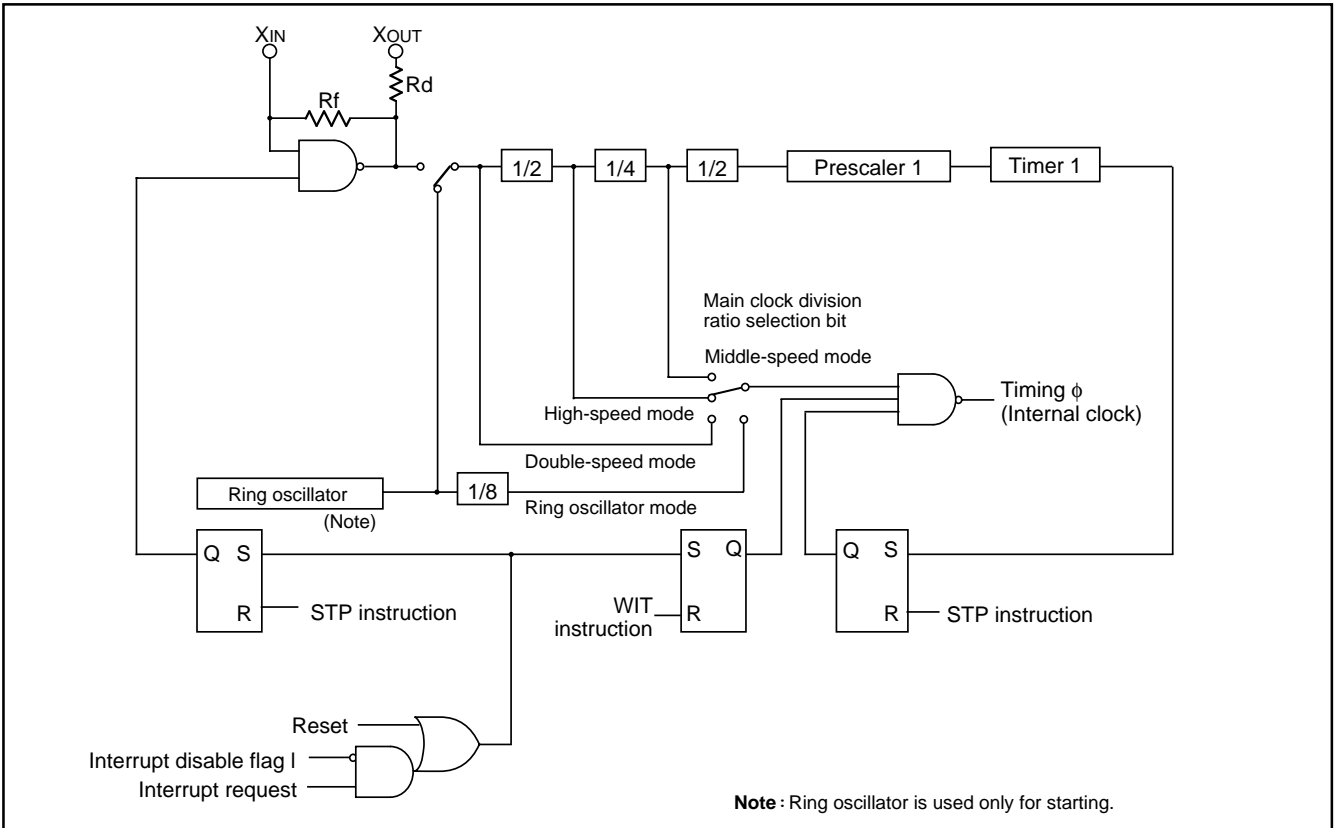

Fig. 47 Block diagram of internal clock generating circuit (for ceramic resonator)

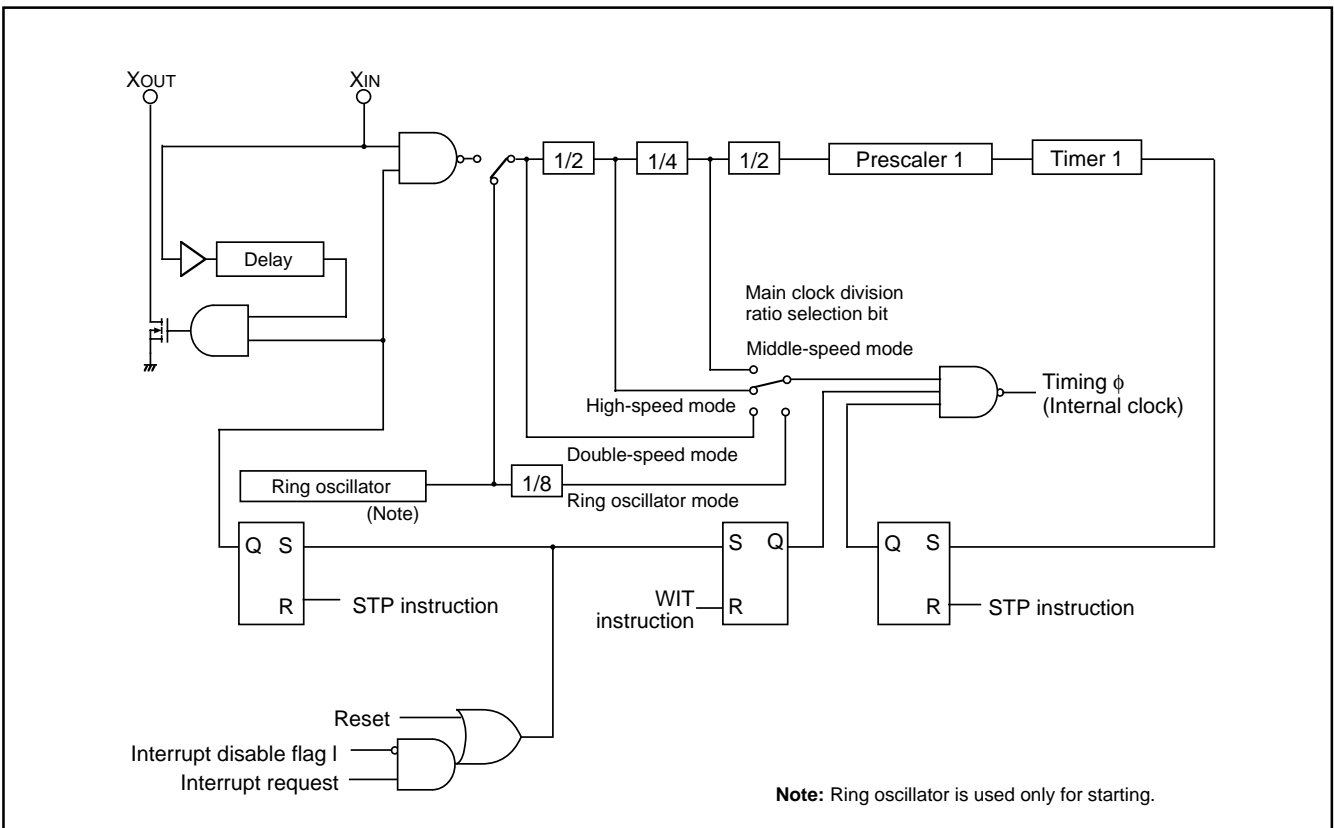

Fig. 48 Block diagram of internal clock generating circuit (for RC oscillation)

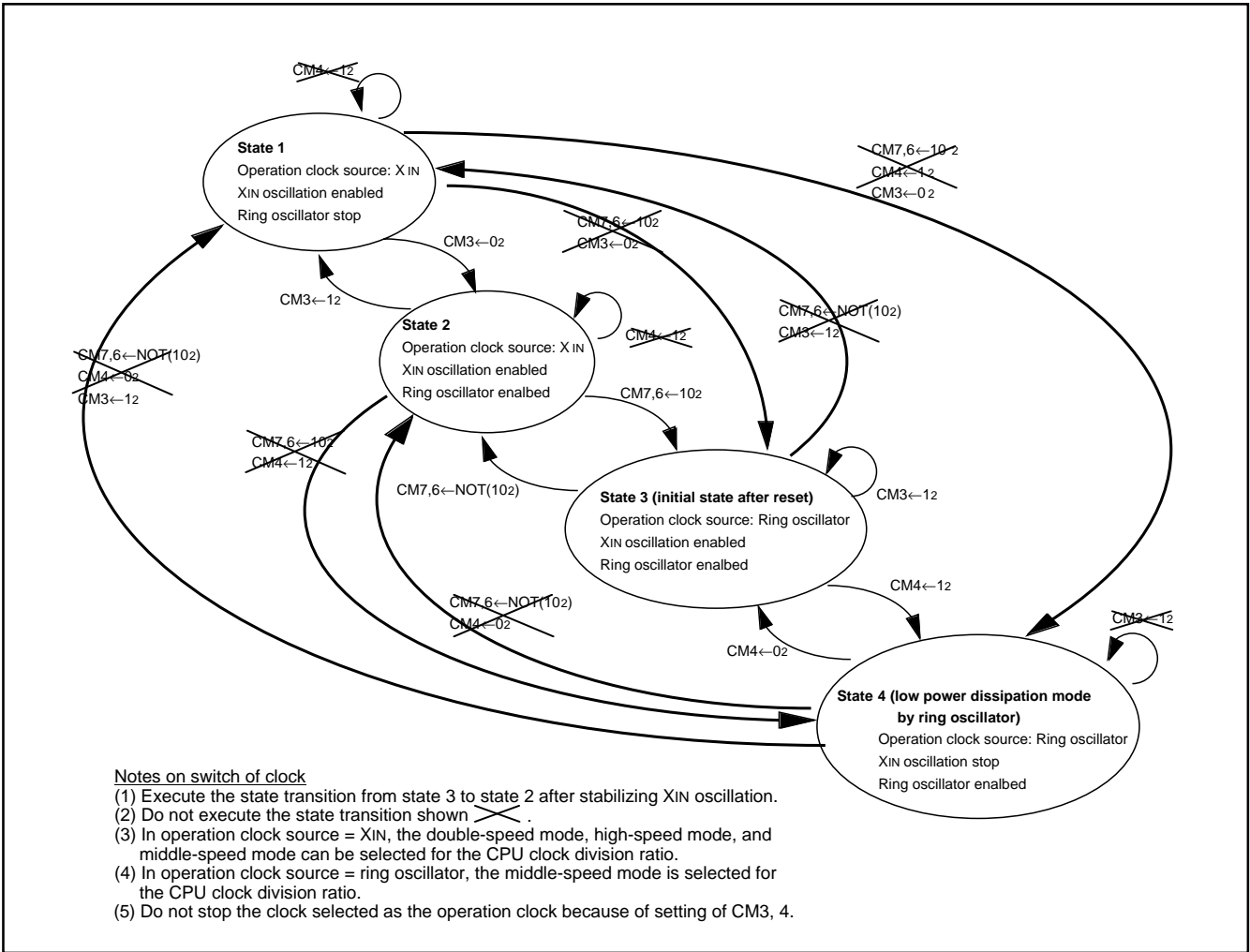

Fig. 49 State transition

PRELIMINARY
 Notice: This is not a final specification.
 Some parametric limits are subject to change.

NOTES ON PROGRAMMING

Processor Status Register

The contents of the processor status register (PS) after reset are undefined except for the interrupt disable flag I which is "1". After reset, initialize flags which affect program execution. In particular, it is essential to initialize the T flag and the D flag because of their effect on calculations.

Interrupts

The contents of the interrupt request bit do not change even if the BBC or BBS instruction is executed immediately after they are changed by program because this instruction is executed for the previous contents. For executing the instruction for the changed contents, execute one instruction before executing the BBC or BBS instruction.

Decimal Calculations

- For calculations in decimal notation, set the decimal mode flag D to "1", then execute the ADC instruction or SBC instruction. In this case, execute SEC instruction, CLC instruction or CLD instruction after executing one instruction before the ADC instruction or SBC instruction.
- In the decimal mode, the values of the N (negative), V (overflow) and Z (zero) flags are invalid.

Timers

- When n (0 to 255) is written to a timer latch, the frequency division ratio is $1/(n+1)$.
- When a count source of timer X, timer Y or timer Z is switched, stop a count of timer X.

Ports

- The values of the port direction registers cannot be read. That is, it is impossible to use the LDA instruction, memory operation instruction when the T flag is "1", addressing mode using direction register values as qualifiers, and bit test instructions such as BBC and BBS. It is also impossible to use bit operation instructions such as CLB and SEB and read/modify/write instructions of direction registers for calculations such as ROR. For setting direction registers, use the LDM instruction, STA instruction, etc.
- P2₆/AN₆, P2₇/AN₇, P3₅ (LED₅), P3₆/INT₁ pins do not exist in the 32-pin version. Stabilize the internal level by setting the port direction registers of these ports to output or setting P3₅, P3₆ pull-up control bits of the pull-up control register (PULL) to ON by program.

A-D Converter

The comparator uses internal capacitors whose charge will be lost if the clock frequency is too low.

Make sure that $f(X_{IN})$ is 500kHz or more during A-D conversion. Do not execute the STP instruction during A-D conversion.

Instruction Execution Timing

The instruction execution time can be obtained by multiplying the frequency of the internal clock ϕ by the number of cycles mentioned in the machine-language instruction table.

The frequency of the internal clock ϕ is the same as that of the X_{IN} in double-speed mode, twice the X_{IN} cycle in high-speed mode and 8 times the X_{IN} cycle in middle-speed mode.

CPU Mode Register

The oscillation mode selection bit and processor mode bits can be rewritten only once after releasing reset. However, after rewriting it is disable to write any value to the bit. (Emulator MCU is excluded.)

When a ceramic oscillation is selected, a double-speed mode of the clock division ratio selection bits can be used. Do not use it when an RC oscillation is selected.

State transition

Do not stop the clock selected as the operation clock because of setting of CM3, 4.

NOTES ON USE

Handling of Power Source Pin

In order to avoid a latch-up occurrence, connect a capacitor suitable for high frequencies as bypass capacitor between power source pin (V_{CC} pin) and GND pin (V_{SS} pin). Besides, connect the capacitor to as close as possible. For bypass capacitor which should not be located too far from the pins to be connected, a ceramic capacitor of 0.01 μ F to 0.1 μ F is recommended.

One Time PROM Version

The CNV_{SS} pin is connected to the internal memory circuit block by a low-ohmic resistance, since it has the multiplexed function to be a programmable power source pin (V_{PP} pin) as well.

To improve the noise reduction, connect a track between CNV_{SS} pin and V_{SS} pin with 1 to 10 k Ω resistance.

The mask ROM version track of CNV_{SS} pin has no operational interference even if it is connected via a resistor.

PRELIMINARY
 Notice: This is not a final specification.
 Some parametric limits are subject to change.

DATA REQUIRED FOR MASK ORDERS

The following are necessary when ordering a mask ROM production:

- (1) Mask ROM Order Confirmation Form
- (2) Mask Specification Form
- (3) Data to be written to ROM, in EPROM form (three identical copies)

ROM PROGRAMMING METHOD

The built-in PROM of the blank One Time PROM version can be read or programmed with a general-purpose PROM programmer using a special programming adapter. Set the address of PROM programmer in the user ROM area.

Table 5 Special programming adapter

Package	Name of Programming Adapter
32P4B	PCA7435SPG02
32P6B-A	PCA7435GPG02
36P2R-A	PCA7435FPG02

The PROM of the blank One Time PROM version is not tested or screened in the assembly process and following processes. To ensure proper operation after programming, the procedure shown in Figure 50 is recommended to verify programming.

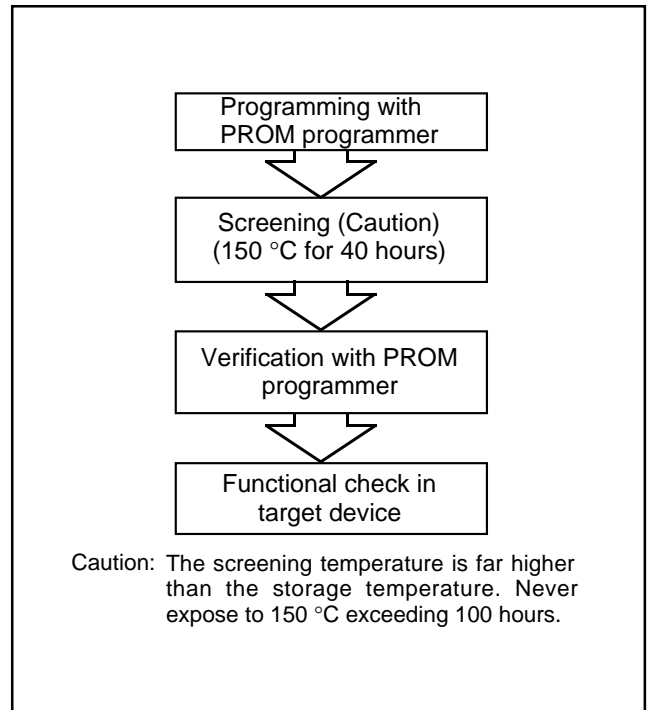

Fig. 50 Programming and testing of One Time PROM version

PRELIMINARY
 Notice: This is not a final specification.
 Some parametric limits are subject to change.

ELECTRICAL CHARACTERISTICS

1.7540Group (General purpose)

Applied to: M37540M4-XXXXFP/SP/GP, M37540E8FP/SP/GP

Absolute Maximum Ratings (General purpose)

Table 6 Absolute maximum ratings

Symbol	Parameter	Conditions	Ratings	Unit
V _{CC}	Power source voltage	All voltages are based on V _{SS} . Output transistors are cut off.	-0.3 to 7.0	V
V _I	Input voltage P00-P07, P10-P14, P20-P27, P30-P37, V _{REF}		-0.3 to V _{CC} + 0.3	V
V _I	Input voltage $\overline{\text{RESET}}$, X _{IN}		-0.3 to V _{CC} + 0.3	V
V _I	Input voltage CNV _{SS} (Note 1)		-0.3 to 13	V
V _O	Output voltage P00-P07, P10-P14, P20-P27, P30-P37, X _{OUT}		-0.3 to V _{CC} + 0.3	V
P _d	Power dissipation	T _a = 25°C	300 (Note 2)	mW
T _{opr}	Operating temperature		-20 to 85	°C
T _{stg}	Storage temperature		-40 to 125	°C

Note 1: It is a rating only for the One Time PROM version. Connect to V_{SS} for the mask ROM version.

2: 200 mW for the 32P6B package product.

PRELIMINARY
 Notice: This is not a final specification.
 Some parametric limits are subject to change.

Recommended Operating Conditions (General purpose)

Table 7 Recommended operating conditions (1) (Vcc = 2.2 to 5.5 V, Ta = -20 to 85 °C, unless otherwise noted)

Symbol	Parameter		Limits			Unit
			Min.	Typ.	Max.	
VCC	Power source voltage (ceramic)	f(XIN) = 8 MHz (High-, Middle-speed mode)	4.0	5.0	5.5	V
		f(XIN) = 4 MHz (High-, Middle-speed mode)	2.4	5.0	5.5	V
		f(XIN) = 2 MHz (High-, Middle-speed mode)	2.2	5.0	5.5	V
		f(XIN) = 4 MHz (Double-speed mode)	4.0	5.0	5.5	V
		f(XIN) = 2 MHz (Double-speed mode)	2.4	5.0	5.5	V
		f(XIN) = 1 MHz (Double-speed mode)	2.2	5.0	5.5	V
	Power source voltage (RC)	f(XIN) = 4 MHz (High-, Middle-speed mode)	4.0	5.0	5.5	V
		f(XIN) = 2 MHz (High-, Middle-speed mode)	2.4	5.0	5.5	V
f(XIN) = 1 MHz (High-, Middle-speed mode)		2.2	5.0	5.5	V	
VSS	Power source voltage			0		V
VREF	Analog reference voltage		2.0		Vcc	V
VIH	"H" input voltage	P00-P07, P10-P14, P20-P27, P30-P37	0.8Vcc		Vcc	V
VIH	"H" input voltage (TTL input level selected)	P10, P12, P13, P36, P37 (Note 1)	2.0		Vcc	V
VIH	"H" input voltage	RESET, XIN	0.8Vcc		Vcc	V
VIL	"L" input voltage	P00-P07, P10-P14, P20-P27, P30-P37	0		0.3Vcc	V
VIL	"L" input voltage (TTL input level selected)	P10, P12, P13, P36, P37 (Note 1)	0		0.8	V
VIL	"L" input voltage	RESET, CNVss	0		0.2Vcc	V
VIL	"L" input voltage	XIN	0		0.16Vcc	V
ΣIOH(peak)	"H" total peak output current (Note 2)	P00-P07, P10-P14, P20-P27, P30-P37			-80	mA
ΣIOL(peak)	"L" total peak output current (Note 2)	P00-P07, P10-P14, P20-P27, P37			80	mA
ΣIOL(peak)	"L" total peak output current (Note 2)	P30-P36			60	mA
ΣIOH(avg)	"H" total average output current (Note 2)	P00-P07, P10-P14, P20-P27, P30-P37			-40	mA
ΣIOL(avg)	"L" total average output current (Note 2)	P00-P07, P10-P14, P20-P27, P37			40	mA
ΣIOL(avg)	"L" total average output current (Note 2)	P30-P36			30	mA

Note 1: Vcc = 4.0 to 5.5V

2: The total output current is the sum of all the currents flowing through all the applicable ports. The total average current is an average value measured over 100 ms. The total peak current is the peak value of all the currents.

PRELIMINARY
 Notice: This is not a final specification.
 Some parametric limits are subject to change.

Recommended Operating Conditions (General purpose)(continued)

Table 8 Recommended operating conditions (2) (Vcc = 2.2 to 5.5 V, Ta = -20 to 85 °C, unless otherwise noted)

Symbol	Parameter		Limits			Unit
			Min.	Typ.	Max.	
IOH(peak)	"H" peak output current (Note 1)	P00-P07, P10-P14, P20-P27, P30-P37			-10	mA
IOL(peak)	"L" peak output current (Note 1)	P00-P07, P10-P14, P20-P27, P37			10	mA
IOL(peak)	"L" peak output current (Note 1)	P30-P36			30	mA
IOH(avg)	"H" average output current (Note 2)	P00-P07, P10-P14, P20-P27, P30-P37			-5	mA
IOL(avg)	"L" average output current (Note 2)	P00-P07, P10-P14, P20-P27, P37			5	mA
IOL(avg)	"L" average output current (Note 2)	P30-P36			15	mA
f(XIN)	Internal clock oscillation frequency (Note 3) at ceramic oscillation or external clock input	Vcc = 4.0 to 5.5 V Double-speed mode			4	MHz
	Internal clock oscillation frequency (Note 3) at ceramic oscillation or external clock input	Vcc = 2.4 to 5.5 V Double-speed mode			2	MHz
	Internal clock oscillation frequency (Note 3) at ceramic oscillation or external clock input	Vcc = 2.2 to 5.5 V Double-speed mode			1	MHz
	Internal clock oscillation frequency (Note 3) at ceramic oscillation or external clock input	Vcc = 4.0 to 5.5 V High-, Middle-speed mode			8	MHz
	Internal clock oscillation frequency (Note 3) at ceramic oscillation or external clock input	Vcc = 2.4 to 5.5 V High-, Middle-speed mode			4	MHz
	Internal clock oscillation frequency (Note 3) at ceramic oscillation or external clock input	Vcc = 2.2 to 5.5 V High-, Middle-speed mode			2	MHz
	Internal clock oscillation frequency (Note 3) at RC oscillation	Vcc = 4.0 to 5.5 V High-, Middle-speed mode			4	MHz
	Internal clock oscillation frequency (Note 3) at RC oscillation	Vcc = 2.4 to 5.5 V High-, Middle-speed mode			2	MHz
	Internal clock oscillation frequency (Note 3) at RC oscillation	Vcc = 2.2 to 5.5 V High-, Middle-speed mode			1	MHz

- Notes 1:** The peak output current is the peak current flowing in each port.
2: The average output current IOL (avg), IOH (avg) in an average value measured over 100 ms.
3: When the oscillation frequency has a duty cycle of 50 %.

PRELIMINARY
 Notice: This is not a final specification.
 Some parametric limits are subject to change.

Electrical Characteristics (General purpose)

Table 9 Electrical characteristics (V_{CC} = 2.2 to 5.5 V, V_{SS} = 0 V, T_a = -20 to 85 °C, unless otherwise noted)

Symbol	Parameter		Test conditions	Limits			Unit
				Min.	Typ.	Max.	
VOH	"H" output voltage P00-P07, P10-P14, P20-P27, P30-P37 (Note 1)		I _{OH} = -5 mA V _{CC} = 4.0 to 5.5 V	V _{CC} -1.5			V
			I _{OH} = -1.0 mA V _{CC} = 2.2 to 5.5 V	V _{CC} -1.0			V
VOL	"L" output voltage P00-P07, P10-P14, P20-P27, P37		I _{OL} = 5 mA V _{CC} = 4.0 to 5.5 V			1.5	V
			I _{OL} = 1.5 mA V _{CC} = 4.0 to 5.5 V			0.3	V
			I _{OL} = 1.0 mA V _{CC} = 2.2 to 5.5 V			1.0	V
VOL	"L" output voltage P30-P36		I _{OL} = 15 mA V _{CC} = 4.0 to 5.5 V			2.0	V
			I _{OL} = 1.5 mA V _{CC} = 4.0 to 5.5 V			0.3	V
			I _{OL} = 10 mA V _{CC} = 2.2 to 5.5 V			1.0	V
VT+–VT–	Hysteresis	CNTR ₀ , CNTR ₁ , INT ₀ , INT ₁ (Note 2) P00-P07 (Note 3)			0.4		V
VT+–VT–	Hysteresis	RxD, SCLK1, SCLK2, SDATA2 (Note 2)			0.5		V
VT+–VT–	Hysteresis	RESET			0.5		V
I _{IH}	"H" input current	P00-P07, P10-P14, P20-P27, P30-P37	V _I = V _{CC} (Pin floating. Pull up transistors "off")			5.0	μA
I _{IH}	"H" input current	RESET	V _I = V _{CC}			5.0	μA
I _{IH}	"H" input current	X _{IN}	V _I = V _{CC}		4.0		μA
I _{IL}	"L" input current	P00-P07, P10-P14, P20-P27, P30-P37	V _I = V _{SS} (Pin floating. Pull up transistors "off")			-5.0	μA
I _{IL}	"L" input current	RESET, CNV _{SS}	V _I = V _{SS}			-5.0	μA
I _{IL}	"L" input current	X _{IN}	V _I = V _{SS}		-4.0		μA
I _{IL}	"L" input current	P00-P07, P30-P37	V _I = V _{SS} (Pull up transistors "on")		-0.2	-0.5	mA
VRAM	RAM hold voltage		When clock stopped	2.0		5.5	V
I _{CC}	Power source current		High-speed mode, f(X _{IN}) = 8 MHz Output transistors "off"		5.0	TBD	mA
			High-speed mode, f(X _{IN}) = 2 MHz, V _{CC} = 2.2 V Output transistors "off"		TBD	TBD	mA
			Double-speed mode, f(X _{IN}) = 4 MHz Output transistors "off"		5.0	TBD	mA
			Middle-speed mode, f(X _{IN}) = 8 MHz Output transistors "off"		2.0	TBD	mA
			f(X _{IN}) = 8 MHz (in WIT state), functions except timer 1 disabled, Output transistors "off"		1.6		mA
			f(X _{IN}) = 2 MHz, V _{CC} = 2.2 V (in WIT state) Output transistors "off"		TBD		mA
			Increment when A-D conversion is executed f(X _{IN}) = 8 MHz, V _{CC} = 5 V		0.7		mA
			All oscillation stopped (in STP state) Output transistors "off"	Ta = 25 °C	0.1	1.0	μA
	Ta = 85 °C		10	μA			

Notes 1: P11 is measured when the P11/TXD1 P-channel output disable bit of the UART control register (bit 4 of address 001B16) is "0".

2: RxD1, SCLK1, SCLK2, SDATA2, INT₀, and INT₁ have hysteresises only when bits 0 to 2 of the port P1P3 control register are set to "0" (CMOS level).

3: It is available only when operating key-on wake up.

PRELIMINARY
 Notice: This is not a final specification.
 Some parametric limits are subject to change.

A-D Converter Characteristics (General purpose)

Table 10 A-D Converter characteristics (1) ($V_{CC} = 2.7$ to 5.5 V, $V_{SS} = 0$ V, $T_a = -20$ to 85 °C, unless otherwise noted)

Symbol	Parameter	Test conditions	Limits			Unit
			Min.	Typ.	Max.	
—	Resolution				10	Bits
—	Linearity error	$V_{CC} = 2.7$ to 5.5 V $T_a = 25$ °C			± 3	LSB
—	Differential nonlinear error	$V_{CC} = 2.7$ to 5.5 V $T_a = 25$ °C			± 0.9	LSB
VOT	Zero transition voltage	$V_{CC} = V_{REF} = 5.12$ V	0	5	20	mV
		$V_{CC} = V_{REF} = 3.072$ V	0	3	15	mV
VFST	Full scale transition voltage	$V_{CC} = V_{REF} = 5.12$ V	5105	5115	5125	mV
		$V_{CC} = V_{REF} = 3.072$ V	3060	3069	3075	mV
tCONV	Conversion time				122	tc(XIN)
RLADDER	Ladder resistor			35		k Ω
IVREF	Reference power source input current	$V_{REF} = 5.0$ V	50	150	200	μ A
		$V_{REF} = 3.0$ V	30	90	120	
II(AD)	A-D port input current				5.0	μ A

PRELIMINARY
 Notice: This is not a final specification.
 Some parametric limits are subject to change.

Timing Requirements (General purpose)

Table 11 Timing requirements (1) ($V_{CC} = 4.0$ to 5.5 V, $V_{SS} = 0$ V, $T_a = -20$ to 85 °C, unless otherwise noted)

Symbol	Parameter	Limits			Unit
		Min.	Typ.	Max.	
$t_{w}(\text{RESET})$	Reset input "L" pulse width	2			μs
$t_{c}(\text{XIN})$	External clock input cycle time	125			ns
$t_{WH}(\text{XIN})$	External clock input "H" pulse width	50			ns
$t_{WL}(\text{XIN})$	External clock input "L" pulse width	50			ns
$t_{c}(\text{CNTR0})$	CNTR0 input cycle time	200			ns
$t_{WH}(\text{CNTR0})$	CNTR0, INT0, INT1, input "H" pulse width	80			ns
$t_{WL}(\text{CNTR0})$	CNTR0, INT0, INT1, input "L" pulse width	80			ns
$t_{c}(\text{CNTR1})$	CNTR1 input cycle time	200			ns
$t_{WH}(\text{CNTR1})$	CNTR1 input "H" pulse width	80			ns
$t_{WL}(\text{CNTR1})$	CNTR1 input "L" pulse width	80			ns
$t_{c}(\text{SCLK1})$	Serial I/O1 clock input cycle time (Note)	2000			ns
$t_{WH}(\text{SCLK1})$	Serial I/O1 clock input "H" pulse width (Note)	950			ns
$t_{WL}(\text{SCLK1})$	Serial I/O1 clock input "L" pulse width (Note)	950			ns
$t_{su}(\text{RxD1-SCLK1})$	Serial I/O1 input set up time	400			ns
$t_{h}(\text{RxD1-SCLK1})$	Serial I/O1 input hold time	200			ns
$t_{c}(\text{SCLK2})$	Serial I/O2 clock input cycle time	1000			ns
$t_{WH}(\text{SCLK2})$	Serial I/O2 clock input "H" pulse width	400			ns
$t_{WL}(\text{SCLK2})$	Serial I/O2 clock input "L" pulse width	400			ns
$t_{su}(\text{SDATA2-SCLK2})$	Serial I/O2 input set up time	200			ns
$t_{h}(\text{SCLK2-SDATA2})$	Serial I/O2 input hold time	200			ns

Note: In this time, bit 6 of the serial I/O1 control register (address 001A16) is set to "1" (clock synchronous serial I/O1 is selected).

When bit 6 of the serial I/O1 control register is "0" (clock asynchronous serial I/O1 is selected), the rating values are divided by 4.

PRELIMINARY
 Notice: This is not a final specification.
 Some parametric limits are subject to change.

Table 12 Timing requirements (2) (V_{CC} = 2.2 to 5.5 V or 2.4 to 5.5 V, V_{SS} = 0 V, T_a = -20 to 85 °C, unless otherwise noted)

Symbol	Parameter	Limits			Unit
		Min.	Typ.	Max.	
t _w (RESET)	Reset input "L" pulse width	2			μs
t _c (XIN)	External clock input cycle time	V _{CC} = 2.2 to 5.5 V	500		ns
		V _{CC} = 2.4 to 5.5 V	250		ns
t _{WH} (XIN)	External clock input "H" pulse width	V _{CC} = 2.2 to 5.5 V	200		ns
		V _{CC} = 2.4 to 5.5 V	100		ns
t _{WL} (XIN)	External clock input "L" pulse width	V _{CC} = 2.2 to 5.5 V	200		ns
		V _{CC} = 2.4 to 5.5 V	100		ns
t _c (CNTR0)	CNTR0 input cycle time	V _{CC} = 2.2 to 5.5 V	1000		ns
		V _{CC} = 2.4 to 5.5 V	500		ns
t _{WH} (CNTR0)	CNTR0, INT0, INT1, input "H" pulse width	V _{CC} = 2.2 to 5.5 V	460		ns
		V _{CC} = 2.4 to 5.5 V	230		ns
t _{WL} (CNTR0)	CNTR0, INT0, INT1, input "L" pulse width	V _{CC} = 2.2 to 5.5 V	460		ns
		V _{CC} = 2.4 to 5.5 V	230		ns
t _c (CNTR1)	CNTR1 input cycle time	V _{CC} = 2.2 to 5.5 V	TBD		ns
		V _{CC} = 2.4 to 5.5 V	TBD		ns
t _{WH} (CNTR1)	CNTR1 input "H" pulse width	V _{CC} = 2.2 to 5.5 V	TBD		ns
		V _{CC} = 2.4 to 5.5 V	TBD		ns
t _{WL} (CNTR1)	CNTR1 input "L" pulse width	V _{CC} = 2.2 to 5.5 V	TBD		ns
		V _{CC} = 2.4 to 5.5 V	TBD		ns
t _c (SCLK1)	Serial I/O1 clock input cycle time	V _{CC} = 2.2 to 5.5 V	TBD		ns
		V _{CC} = 2.4 to 5.5 V	TBD		ns
t _{WH} (SCLK1)	Serial I/O1 clock input "H" pulse width	V _{CC} = 2.2 to 5.5 V	TBD		ns
		V _{CC} = 2.4 to 5.5 V	TBD		ns
t _{WL} (SCLK1)	Serial I/O1 clock input "L" pulse width	V _{CC} = 2.2 to 5.5 V	TBD		ns
		V _{CC} = 2.4 to 5.5 V	TBD		ns
t _{su} (SDATA1-SCLK1)	Serial I/O1 input set up time	TBD			ns
t _h (SCLK1-SDATA1)	Serial I/O1 input hold time	TBD			ns
t _c (SCLK2)	Serial I/O2 clock input cycle time	V _{CC} = 2.2 to 5.5 V	4000		ns
		V _{CC} = 2.4 to 5.5 V	2000		ns
t _{WH} (SCLK2)	Serial I/O2 clock input "H" pulse width	V _{CC} = 2.2 to 5.5 V	1900		ns
		V _{CC} = 2.4 to 5.5 V	950		ns
t _{WL} (SCLK2)	Serial I/O2 clock input "L" pulse width	V _{CC} = 2.2 to 5.5 V	1900		ns
		V _{CC} = 2.4 to 5.5 V	950		ns
t _{su} (SDATA2-SCLK2)	Serial I/O2 input set up time	400			ns
t _h (SCLK2-SDATA2)	Serial I/O2 input hold time	400			ns

PRELIMINARY
 Notice: This is not a final specification.
 Some parametric limits are subject to change.

Switching Characteristics (General purpose)

Table 13 Switching characteristics (1) ($V_{CC} = 4.0$ to 5.5 V, $V_{SS} = 0$ V, $T_a = -20$ to 85 °C, unless otherwise noted)

Symbol	Parameter	Limits			Unit
		Min.	Typ.	Max.	
t _{WH} (SCLK1)	Serial I/O1 clock output "H" pulse width	t _c (SCLK1)/2-30			ns
t _{WL} (SCLK1)	Serial I/O1 clock output "L" pulse width	t _c (SCLK1)/2-30			ns
t _d (SCLK1-TxD1)	Serial I/O1 output delay time			140	ns
t _v (SCLK1-TxD1)	Serial I/O1 output valid time	-30			ns
t _r (SCLK1)	Serial I/O1 clock output rising time			30	ns
t _f (SCLK1)	Serial I/O1 clock output falling time			30	ns
t _{WH} (SCLK2)	Serial I/O2 clock output "H" pulse width	t _c (SCLK2)/2-30			ns
t _{WL} (SCLK2)	Serial I/O2 clock output "L" pulse width	t _c (SCLK2)/2-30			ns
t _d (SCLK2-SDATA2)	Serial I/O2 output delay time			140	ns
t _v (SCLK2-SDATA2)	Serial I/O2 output valid time	0			ns
t _r (SCLK2)	Serial I/O2 clock output rising time			30	ns
t _f (SCLK2)	Serial I/O2 clock output falling time			30	ns
t _r (CMOS)	CMOS output rising time (Note 1)		10	30	ns
t _f (CMOS)	CMOS output falling time (Note 1)		10	30	ns

Note 1: Pin XOUT is excluded.

Table 14 Switching characteristics (2) ($V_{CC} = 2.2$ to 5.5 V, $V_{SS} = 0$ V, $T_a = -20$ to 85 °C, unless otherwise noted)

Symbol	Parameter	Limits			Unit
		Min.	Typ.	Max.	
t _{WH} (SCLK1)	Serial I/O1 clock output "H" pulse width	TBD			ns
t _{WL} (SCLK1)	Serial I/O1 clock output "L" pulse width	TBD			ns
t _d (SCLK1-TxD1)	Serial I/O1 output delay time			TBD	ns
t _v (SCLK1-TxD1)	Serial I/O1 output valid time	TBD			ns
t _r (SCLK1)	Serial I/O1 clock output rising time			TBD	ns
t _f (SCLK1)	Serial I/O1 clock output falling time			TBD	ns
t _{WH} (SCLK2)	Serial I/O2 clock output "H" pulse width	t _c (SCLK2)/2-50			ns
t _{WL} (SCLK2)	Serial I/O2 clock output "L" pulse width	t _c (SCLK2)/2-50			ns
t _d (SCLK2-SDATA2)	Serial I/O2 output delay time			350	ns
t _v (SCLK2-SDATA2)	Serial I/O2 output valid time	0			ns
t _r (SCLK2)	Serial I/O2 clock output rising time			50	ns
t _f (SCLK2)	Serial I/O2 clock output falling time			50	ns
t _r (CMOS)	CMOS output rising time (Note 1)		20	50	ns
t _f (CMOS)	CMOS output falling time (Note 1)		20	50	ns

Note 1: Pin XOUT is excluded.

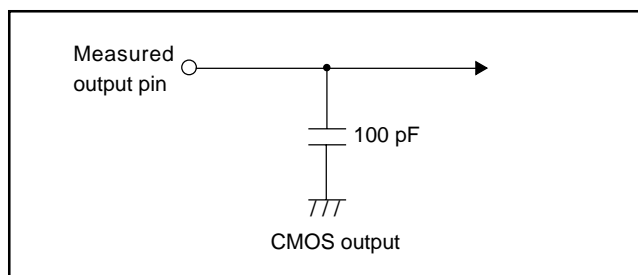

Switching characteristics measurement circuit diagram (General purpose)

PRELIMINARY
 Notice: This is not a final specification.
 Some parametric limits are subject to change.

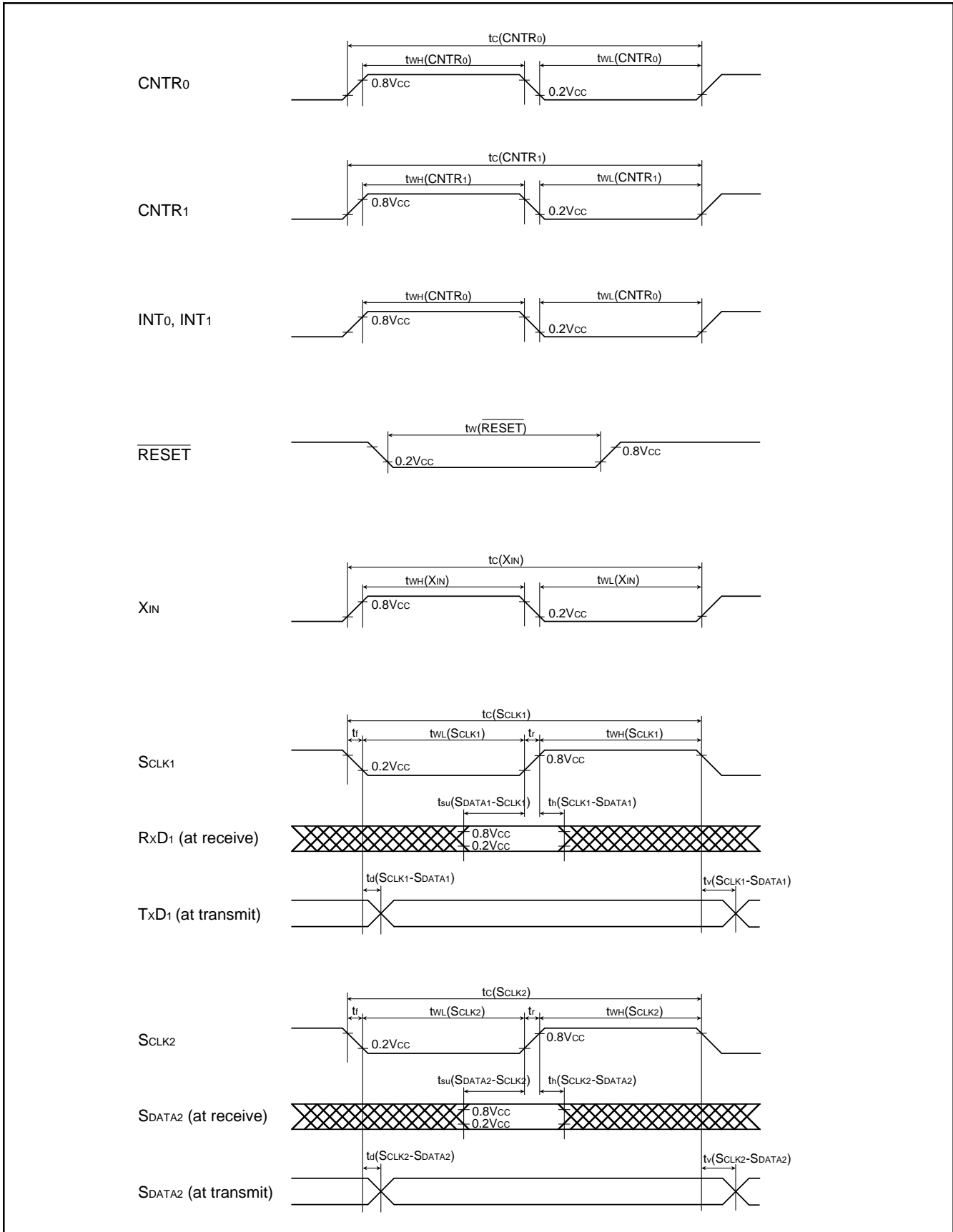

Fig. 51 Timing chart (General purpose)

PRELIMINARY
 Notice: This is not a final specification.
 Some parametric limits are subject to change.

ELECTRICAL CHARACTERISTICS

2.7540Group (Extended operating temperature version)

Applied to: M37540M4T-XXXFP/GP

Absolute Maximum Ratings (Extended operating temperature version)

Table 15 Absolute maximum ratings

Symbol	Parameter	Conditions	Ratings	Unit
V _{CC}	Power source voltage		-0.3 to 7.0	V
V _I	Input voltage P00-P07, P10-P14, P20-P27, P30-P37, V _{REF}	All voltages are based on V _{SS} . Output transistors are cut off.	-0.3 to V _{CC} + 0.3	V
V _I	Input voltage $\overline{\text{RESET}}$, X _{IN} , CNV _{SS}		-0.3 to V _{CC} + 0.3	V
V _O	Output voltage P00-P07, P10-P14, P20-P27, P30-P37, X _{OUT}		-0.3 to V _{CC} + 0.3	V
P _d	Power dissipation	T _a = 25°C	300 (Note)	mW
T _{opr}	Operating temperature		-40 to 85	°C
T _{stg}	Storage temperature		-65 to 150	°C

Note : 200 mW for the 32P6B package product.

PRELIMINARY
 Notice: This is not a final specification.
 Some parametric limits are subject to change.

Recommended Operating Conditions (Extended operating temperature version)

Table 16 Recommended operating conditions (1) (Vcc = 2.2 to 5.5 V, Ta = -40 to 85 °C, unless otherwise noted)

Symbol	Parameter		Limits			Unit
			Min.	Typ.	Max.	
VCC	Power source voltage (ceramic)	f(XIN) = 8 MHz (High-, Middle-speed mode)	4.0	5.0	5.5	V
		f(XIN) = 4 MHz (High-, Middle-speed mode)	2.4	5.0	5.5	V
		f(XIN) = 2 MHz (High-, Middle-speed mode)	2.2	5.0	5.5	V
		f(XIN) = 4 MHz (Double-speed mode)	4.0	5.0	5.5	V
		f(XIN) = 2 MHz (Double-speed mode)	2.4	5.0	5.5	V
	Power source voltage (RC)	f(XIN) = 4 MHz (High-, Middle-speed mode)	4.0	5.0	5.5	V
		f(XIN) = 2 MHz (High-, Middle-speed mode)	2.4	5.0	5.5	V
VSS	Power source voltage			0		V
VREF	Analog reference voltage		2.0		Vcc	V
VIH	"H" input voltage	P00-P07, P10-P14, P20-P27, P30-P37	0.8Vcc		Vcc	V
VIH	"H" input voltage (TTL input level selected)	P10, P12, P13, P36, P37 (Note 1)	2.0		Vcc	V
VIH	"H" input voltage	RESET, XIN	0.8Vcc		Vcc	V
VIL	"L" input voltage	P00-P07, P10-P14, P20-P27, P30-P37	0		0.3Vcc	V
VIL	"L" input voltage (TTL input level selected)	P10, P12, P13, P36, P37 (Note 1)	0		0.8	V
VIL	"L" input voltage	RESET, CNVss	0		0.2Vcc	V
VIL	"L" input voltage	XIN	0		0.16Vcc	V
ΣIOH(peak)	"H" total peak output current (Note 2)	P00-P07, P10-P14, P20-P27, P30-P37			-80	mA
ΣIOL(peak)	"L" total peak output current (Note 2)	P00-P07, P10-P14, P20-P27, P37			80	mA
ΣIOL(peak)	"L" total peak output current (Note 2)	P30-P36			60	mA
ΣIOH(avg)	"H" total average output current (Note 2)	P00-P07, P10-P14, P20-P27, P30-P37			-40	mA
ΣIOL(avg)	"L" total average output current (Note 2)	P00-P07, P10-P14, P20-P27, P37			40	mA
ΣIOL(avg)	"L" total average output current (Note 2)	P30-P36			30	mA

Note 1: Vcc = 4.0 to 5.5V

2: The total output current is the sum of all the currents flowing through all the applicable ports. The total average current is an average value measured over 100 ms. The total peak current is the peak value of all the currents.

PRELIMINARY
 Notice: This is not a final specification.
 Some parametric limits are subject to change.

Recommended Operating Conditions (Extended operating temperature version)

Table 17 Recommended operating conditions (2) (Vcc = 2.2 to 5.5 V, Ta = -40 to 85 °C, unless otherwise noted)

Symbol	Parameter		Limits			Unit
			Min.	Typ.	Max.	
IOH(peak)	"H" peak output current (Note 1)	P00-P07, P10-P14, P20-P27, P30-P37			-10	mA
IOL(peak)	"L" peak output current (Note 1)	P00-P07, P10-P14, P20-P27, P37			10	mA
IOL(peak)	"L" peak output current (Note 1)	P30-P36			30	mA
IOH(avg)	"H" average output current (Note 2)	P00-P07, P10-P14, P20-P27, P30-P37			-5	mA
IOL(avg)	"L" average output current (Note 2)	P00-P07, P10-P14, P20-P27, P37			5	mA
IOL(avg)	"L" average output current (Note 2)	P30-P36			15	mA
f(XIN)	Internal clock oscillation frequency (Note 3) at ceramic oscillation or external clock input	Vcc = 4.0 to 5.5 V Double-speed mode			4	MHz
	Internal clock oscillation frequency (Note 3) at ceramic oscillation or external clock input	Vcc = 2.4 to 5.5 V Double-speed mode			2	MHz
	Internal clock oscillation frequency (Note 3) at ceramic oscillation or external clock input	Vcc = 4.0 to 5.5 V High-, Middle-speed mode			8	MHz
	Internal clock oscillation frequency (Note 3) at ceramic oscillation or external clock input	Vcc = 2.4 to 5.5 V High-, Middle-speed mode			4	MHz
	Internal clock oscillation frequency (Note 3) at ceramic oscillation or external clock input	Vcc = 2.2 to 5.5 V High-, Middle-speed mode			2	MHz
	Internal clock oscillation frequency (Note 3) at RC oscillation	Vcc = 4.0 to 5.5 V High-, Middle-speed mode			4	MHz
	Internal clock oscillation frequency (Note 3) at RC oscillation	Vcc = 2.4 to 5.5 V High-, Middle-speed mode			2	MHz

- Notes 1:** The peak output current is the peak current flowing in each port.
2: The average output current IOL (avg), IOH (avg) in an average value measured over 100 ms.
3: When the oscillation frequency has a duty cycle of 50 %.

PRELIMINARY
 Notice: This is not a final specification.
 Some parametric limits are subject to change.

Electrical Characteristics (Extended operating temperature version)

Table 18 Electrical characteristics (VCC = 2.2 to 5.5 V, VSS = 0 V, Ta = -40 to 85 °C, unless otherwise noted)

Symbol	Parameter		Test conditions	Limits			Unit
				Min.	Typ.	Max.	
VOH	"H" output voltage P00-P07, P10-P14, P20-P27, P30-P37 (Note 1)		IOH = -5 mA VCC = 4.0 to 5.5 V	VCC-1.5			V
			IOH = -1.0 mA VCC = 2.2 to 5.5 V	VCC-1.0			V
VOL	"L" output voltage P00-P07, P10-P14, P20-P27, P37		IOl = 5 mA VCC = 4.0 to 5.5 V			1.5	V
			IOl = 1.5 mA VCC = 4.0 to 5.5 V			0.3	V
			IOl = 1.0 mA VCC = 2.2 to 5.5 V			1.0	V
VOL	"L" output voltage P30-P36		IOl = 15 mA VCC = 4.0 to 5.5 V			2.0	V
			IOl = 1.5 mA VCC = 4.0 to 5.5 V			0.3	V
			IOl = 10 mA VCC = 2.2 to 5.5 V			1.0	V
VT+–VT–	Hysteresis	CNTR0, CNTR1, INT0, INT1 (Note 2) P00-P07 (Note 3)		0.4			V
VT+–VT–	Hysteresis	RxD1, SCLK1, SCLK2, SDATA2 (Note 2)		0.5			V
VT+–VT–	Hysteresis	RESET		0.5			V
IiH	"H" input current	P00-P07, P10-P14, P20-P27, P30-P37	Vi = VCC (Pin floating. Pull up transistors "off")			5.0	µA
IiH	"H" input current	RESET	Vi = VCC			5.0	µA
IiH	"H" input current	XIN	Vi = VCC	4.0			µA
IiL	"L" input current	P00-P07, P10-P14, P20-P27, P30-P37	Vi = VSS (Pin floating. Pull up transistors "off")			-5.0	µA
IiL	"L" input current	RESET, CNVSS	Vi = VSS			-5.0	µA
IiL	"L" input current	XIN	Vi = VSS	-4.0			µA
IiL	"L" input current	P00-P07, P30-P37	Vi = VSS (Pull up transistors "on")		-0.2	-0.5	mA
VRAM	RAM hold voltage		When clock stopped	2.0		5.5	V
ICC	Power source current		High-speed mode, f(XIN) = 8 MHz Output transistors "off"		5.0	TBD	mA
			High-speed mode, f(XIN) = 2 MHz, VCC = 2.2 V Output transistors "off"		TBD	TBD	mA
			Double-speed mode, f(XIN) = 4 MHz Output transistors "off"		5.0	TBD	mA
			Middle-speed mode, f(XIN) = 8 MHz Output transistors "off"		2.0	TBD	mA
			f(XIN) = 8 MHz (in WIT state), functions except timer 1 disabled, Output transistors "off"		1.6		mA
			f(XIN) = 2 MHz, VCC = 2.2 V (in WIT state) Output transistors "off"		TBD		mA
			Increment when A-D conversion is executed f(XIN) = 8 MHz, VCC = 5 V		0.7		mA
			All oscillation stopped (in STP state) Output transistors "off"	Ta = 25 °C	0.1	1.0	µA
	Ta = 85 °C		10	µA			

- Notes 1:** P11 is measured when the P11/TXD1 P-channel output disable bit of the UART control register (bit 4 of address 001B16) is "0".
2: RxD1, SCLK1, SCLK2, SDATA2, INT0, and INT1 have hysteresises only when bits 0 to 2 of the port P1P3 control register are set to "0" (CMOS level).
3: It is available only when operating key-on wake up.

PRELIMINARY
 Notice: This is not a final specification.
 Some parametric limits are subject to change.

A-D Converter Characteristics (Extended operating temperature version)

Table 19 A-D Converter characteristics (1) ($V_{CC} = 2.7$ to 5.5 V, $V_{SS} = 0$ V, $T_a = -40$ to 85 °C, unless otherwise noted)

Symbol	Parameter	Test conditions	Limits			Unit
			Min.	Typ.	Max.	
—	Resolution				10	Bits
—	Linearity error	$V_{CC} = 2.7$ to 5.5 V $T_a = 25$ °C			± 3	LSB
—	Differential nonlinear error	$V_{CC} = 2.7$ to 5.5 V $T_a = 25$ °C			± 0.9	LSB
VOT	Zero transition voltage	$V_{CC} = V_{REF} = 5.12$ V	0	5	20	mV
		$V_{CC} = V_{REF} = 3.072$ V	0	3	15	mV
VFST	Full scale transition voltage	$V_{CC} = V_{REF} = 5.12$ V	5105	5115	5125	mV
		$V_{CC} = V_{REF} = 3.072$ V	3060	3069	3075	mV
tCONV	Conversion time			122	tc(XIN)	
RLADDER	Ladder resistor			35	k Ω	
IVREF	Reference power source input current	$V_{REF} = 5.0$ V	50	150	200	μ A
		$V_{REF} = 3.0$ V	30	90	120	
I _{I(AD)}	A-D port input current			5.0	μ A	

PRELIMINARY
 Notice: This is not a final specification.
 Some parametric limits are subject to change.

Timing Requirements (Extended operating temperature version)

Table 20 Timing requirements (1) (Vcc = 4.0 to 5.5 V, Vss = 0 V, Ta = -40 to 85 °C, unless otherwise noted)

Symbol	Parameter	Limits			Unit
		Min.	Typ.	Max.	
t _w (RESET)	Reset input "L" pulse width	2			μs
t _c (XIN)	External clock input cycle time	125			ns
t _{WH} (XIN)	External clock input "H" pulse width	50			ns
t _{WL} (XIN)	External clock input "L" pulse width	50			ns
t _c (CNTR0)	CNTR0 input cycle time	200			ns
t _{WH} (CNTR0)	CNTR0, INT0, INT1, input "H" pulse width	80			ns
t _{WL} (CNTR0)	CNTR0, INT0, INT1, input "L" pulse width	80			ns
t _c (CNTR1)	CNTR1 input cycle time	200			ns
t _{WH} (CNTR1)	CNTR1 input "H" pulse width	80			ns
t _{WL} (CNTR1)	CNTR1 input "L" pulse width	80			ns
t _c (SCLK1)	Serial I/O1 clock input cycle time (Note)	2000			ns
t _{WH} (SCLK1)	Serial I/O1 clock input "H" pulse width (Note)	950			ns
t _{WL} (SCLK1)	Serial I/O1 clock input "L" pulse width (Note)	950			ns
t _{su} (RxD1-SCLK1)	Serial I/O1 input set up time	400			ns
t _h (RxD1-SCLK1)	Serial I/O1 input hold time	200			ns
t _c (SCLK2)	Serial I/O2 clock input cycle time	1000			ns
t _{WH} (SCLK2)	Serial I/O2 clock input "H" pulse width	400			ns
t _{WL} (SCLK2)	Serial I/O2 clock input "L" pulse width	400			ns
t _{su} (SDATA2-SCLK2)	Serial I/O2 input set up time	200			ns
t _h (SCLK2-SDATA2)	Serial I/O2 input hold time	200			ns

Note: In this time, bit 6 of the serial I/O1 control register (address 001A16) is set to "1" (clock synchronous serial I/O1 is selected).

When bit 6 of the serial I/O1 control register is "0" (clock asynchronous serial I/O1 is selected), the rating values are divided by 4.

PRELIMINARY
 Notice: This is not a final specification.
 Some parametric limits are subject to change.

Table 21 Timing requirements (2) (V_{CC} = 2.2 to 5.5 V or 2.4 to 5.5 V, V_{SS} = 0 V, T_a = -40 to 85 °C, unless otherwise noted)

Symbol	Parameter	Limits			Unit
		Min.	Typ.	Max.	
t _w (RESET)	Reset input "L" pulse width	2			μs
t _c (XIN)	External clock input cycle time	V _{CC} = 2.2 to 5.5 V	500		ns
		V _{CC} = 2.4 to 5.5 V	250		ns
t _{WH} (XIN)	External clock input "H" pulse width	V _{CC} = 2.2 to 5.5 V	200		ns
		V _{CC} = 2.4 to 5.5 V	100		ns
t _{WL} (XIN)	External clock input "L" pulse width	V _{CC} = 2.2 to 5.5 V	200		ns
		V _{CC} = 2.4 to 5.5 V	100		ns
t _c (CNTR0)	CNTR0 input cycle time	V _{CC} = 2.2 to 5.5 V	1000		ns
		V _{CC} = 2.4 to 5.5 V	500		ns
t _{WH} (CNTR0)	CNTR0, INT0, INT1, input "H" pulse width	V _{CC} = 2.2 to 5.5 V	460		ns
		V _{CC} = 2.4 to 5.5 V	230		ns
t _{WL} (CNTR0)	CNTR0, INT0, INT1, input "L" pulse width	V _{CC} = 2.2 to 5.5 V	460		ns
		V _{CC} = 2.4 to 5.5 V	230		ns
t _c (CNTR1)	CNTR1 input cycle time	V _{CC} = 2.2 to 5.5 V	TBD		ns
		V _{CC} = 2.4 to 5.5 V	TBD		ns
t _{WH} (CNTR1)	CNTR1 input "H" pulse width	V _{CC} = 2.2 to 5.5 V	TBD		ns
		V _{CC} = 2.4 to 5.5 V	TBD		ns
t _{WL} (CNTR1)	CNTR1 input "L" pulse width	V _{CC} = 2.2 to 5.5 V	TBD		ns
		V _{CC} = 2.4 to 5.5 V	TBD		ns
t _c (SCLK1)	Serial I/O1 clock input cycle time	V _{CC} = 2.2 to 5.5 V	TBD		ns
		V _{CC} = 2.4 to 5.5 V	TBD		ns
t _{WH} (SCLK1)	Serial I/O1 clock input "H" pulse width	V _{CC} = 2.2 to 5.5 V	TBD		ns
		V _{CC} = 2.4 to 5.5 V	TBD		ns
t _{WL} (SCLK1)	Serial I/O1 clock input "L" pulse width	V _{CC} = 2.2 to 5.5 V	TBD		ns
		V _{CC} = 2.4 to 5.5 V	TBD		ns
t _{su} (SDATA1-SCLK1)	Serial I/O1 input set up time		TBD		ns
t _h (SCLK1-SDATA1)	Serial I/O1 input hold time		TBD		ns
t _c (SCLK2)	Serial I/O2 clock input cycle time	V _{CC} = 2.2 to 5.5 V	4000		ns
		V _{CC} = 2.4 to 5.5 V	2000		ns
t _{WH} (SCLK2)	Serial I/O2 clock input "H" pulse width	V _{CC} = 2.2 to 5.5 V	1900		ns
		V _{CC} = 2.4 to 5.5 V	950		ns
t _{WL} (SCLK2)	Serial I/O2 clock input "L" pulse width	V _{CC} = 2.2 to 5.5 V	1900		ns
		V _{CC} = 2.4 to 5.5 V	950		ns
t _{su} (SDATA2-SCLK2)	Serial I/O2 input set up time		400		ns
t _h (SCLK2-SDATA2)	Serial I/O2 input hold time		400		ns

PRELIMINARY
 Notice: This is not a final specification.
 Some parametric limits are subject to change.

Switching Characteristics (Extended operating temperature version)

Table 22 Switching characteristics (1) (V_{CC} = 4.0 to 5.5 V, V_{SS} = 0 V, T_a = -40 to 85 °C, unless otherwise noted)

Symbol	Parameter	Limits			Unit
		Min.	Typ.	Max.	
t _{WH} (SCLK1)	Serial I/O1 clock output "H" pulse width	t _c (SCLK1)/2-30			ns
t _{WL} (SCLK1)	Serial I/O1 clock output "L" pulse width	t _c (SCLK1)/2-30			ns
t _d (SCLK1-TxD1)	Serial I/O1 output delay time			140	ns
t _v (SCLK1-TxD1)	Serial I/O1 output valid time	-30			ns
t _r (SCLK1)	Serial I/O1 clock output rising time			30	ns
t _f (SCLK1)	Serial I/O1 clock output falling time			30	ns
t _{WH} (SCLK2)	Serial I/O2 clock output "H" pulse width	t _c (SCLK2)/2-30			ns
t _{WL} (SCLK2)	Serial I/O2 clock output "L" pulse width	t _c (SCLK2)/2-30			ns
t _d (SCLK2-SDATA2)	Serial I/O2 output delay time			140	ns
t _v (SCLK2-SDATA2)	Serial I/O2 output valid time	0			ns
t _r (SCLK2)	Serial I/O2 clock output rising time			30	ns
t _f (SCLK2)	Serial I/O2 clock output falling time			30	ns
t _r (CMOS)	CMOS output rising time (Note 1)		10	30	ns
t _f (CMOS)	CMOS output falling time (Note 1)		10	30	ns

Note 1: Pin XOUT is excluded.

Table 23 Switching characteristics (2) (V_{CC} = 2.2 to 5.5 V, V_{SS} = 0 V, T_a = -40 to 85 °C, unless otherwise noted)

Symbol	Parameter	Limits			Unit
		Min.	Typ.	Max.	
t _{WH} (SCLK1)	Serial I/O1 clock output "H" pulse width	TBD			ns
t _{WL} (SCLK1)	Serial I/O1 clock output "L" pulse width	TBD			ns
t _d (SCLK1-TxD1)	Serial I/O1 output delay time			TBD	ns
t _v (SCLK1-TxD1)	Serial I/O1 output valid time	TBD			ns
t _r (SCLK1)	Serial I/O1 clock output rising time			TBD	ns
t _f (SCLK1)	Serial I/O1 clock output falling time			TBD	ns
t _{WH} (SCLK2)	Serial I/O2 clock output "H" pulse width	t _c (SCLK2)/2-50			ns
t _{WL} (SCLK2)	Serial I/O2 clock output "L" pulse width	t _c (SCLK2)/2-50			ns
t _d (SCLK2-SDATA2)	Serial I/O2 output delay time			350	ns
t _v (SCLK2-SDATA2)	Serial I/O2 output valid time	0			ns
t _r (SCLK2)	Serial I/O2 clock output rising time			50	ns
t _f (SCLK2)	Serial I/O2 clock output falling time			50	ns
t _r (CMOS)	CMOS output rising time (Note 1)		20	50	ns
t _f (CMOS)	CMOS output falling time (Note 1)		20	50	ns

Note 1: Pin XOUT is excluded.

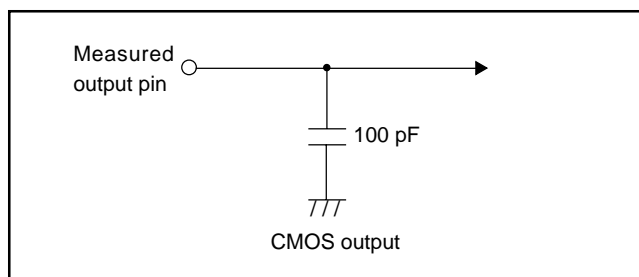

Switching characteristics measurement circuit diagram (General purpose)

PRELIMINARY
 Notice: This is not a final specification.
 Some parametric limits are subject to change.

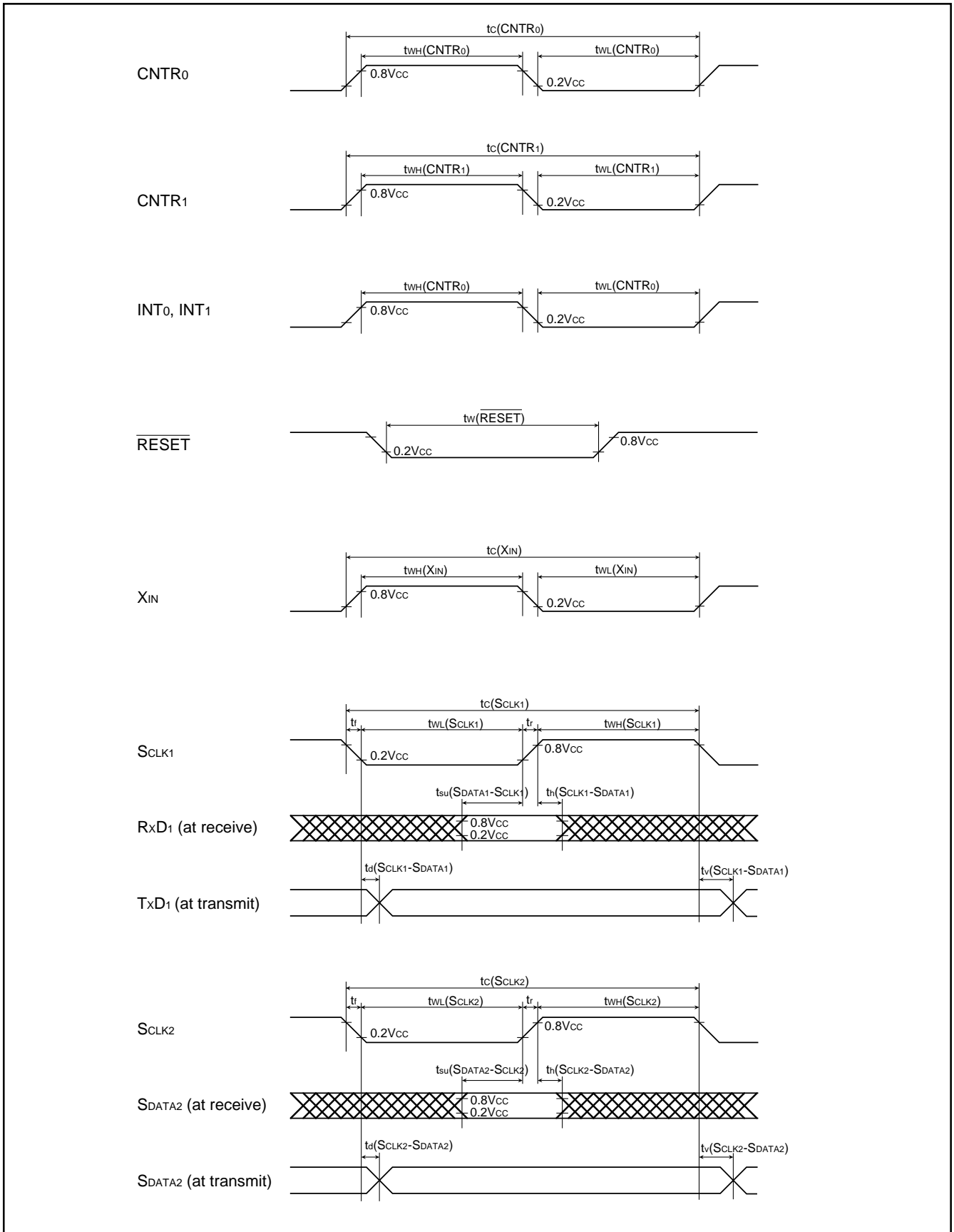

Fig. 52 Timing chart (Extended operating temperature version)

PRELIMINARY
 Notice: This is not a final specification.
 Some parametric limits are subject to change.

PACKAGE OUTLINE

36P2R-A

Plastic 36pin 450mil SSOP

EIAJ Package Code	JEDEC Code	Weight(g)	Lead Material
SSOP36-P-450-0.80	-	0.53	Alloy 42

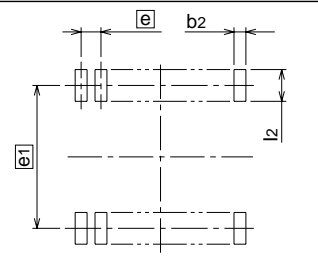
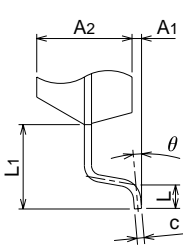
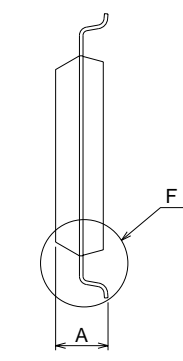
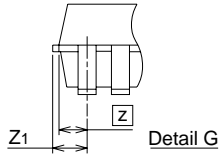
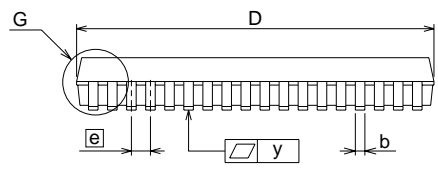
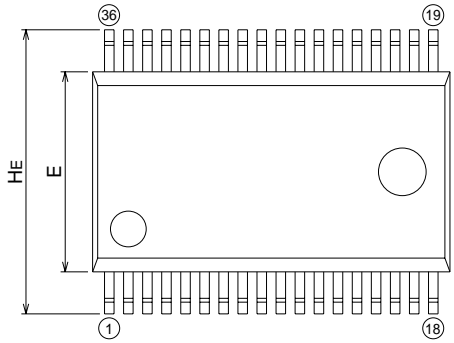

Recommended Mount Pad

Symbol	Dimension in Millimeters		
	Min	Nom	Max
A	-	-	2.4
A1	0.05	-	-
A2	-	2.0	-
b	0.35	0.4	0.5
c	0.13	0.15	0.2
D	14.8	15.0	15.2
E	8.2	8.4	8.6
e	-	0.8	-
HE	11.63	11.93	12.23
L	0.3	0.5	0.7
L1	-	1.765	-
Z	-	0.7	-
Z1	-	-	0.85
y	-	-	0.15
theta	0°	-	10°
b2	-	0.5	-
e1	-	11.43	-
l2	1.27	-	-

32P6B-A

Plastic 32pin 7X7mm body LQFP

EIAJ Package Code	JEDEC Code	Weight(g)	Lead Material
LQFP32-P-77-0.80	-	0.17	Alloy 42

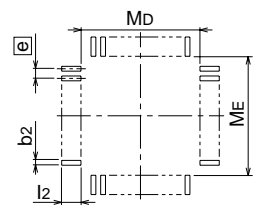
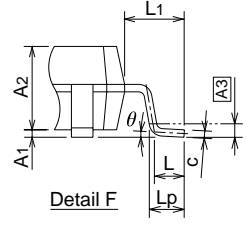
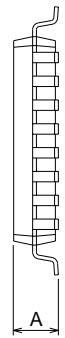
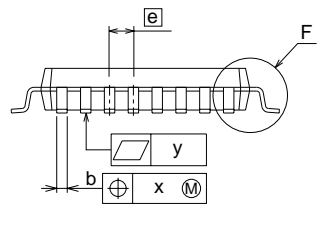
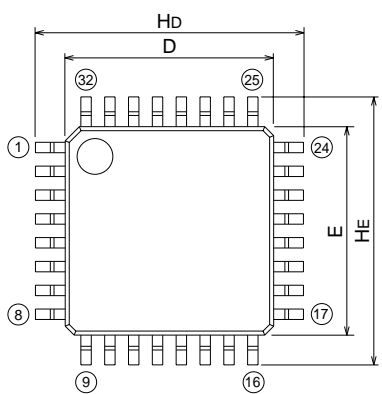

Recommended Mount Pad

Symbol	Dimension in Millimeters		
	Min	Nom	Max
A	-	-	1.7
A1	0	0.1	0.2
A2	-	1.4	-
b	0.3	0.35	0.45
c	0.105	0.125	0.175
D	6.9	7.0	7.1
E	6.9	7.0	7.1
e	-	0.8	-
Hd	8.8	9.0	9.2
HE	8.8	9.0	9.2
L	0.3	0.5	0.7
L1	-	1.0	-
Lp	0.45	0.6	0.75
A3	-	0.25	-
x	-	-	0.2
y	-	-	0.1
theta	0°	-	10°
b2	-	0.5	-
l2	1.0	-	-
Md	-	7.4	-
ME	-	7.4	-

PRELIMINARY
 Notice: This is not a final specification.
 Some parametric limits are subject to change.

32P4B

Plastic 32pin 400mil SDIP

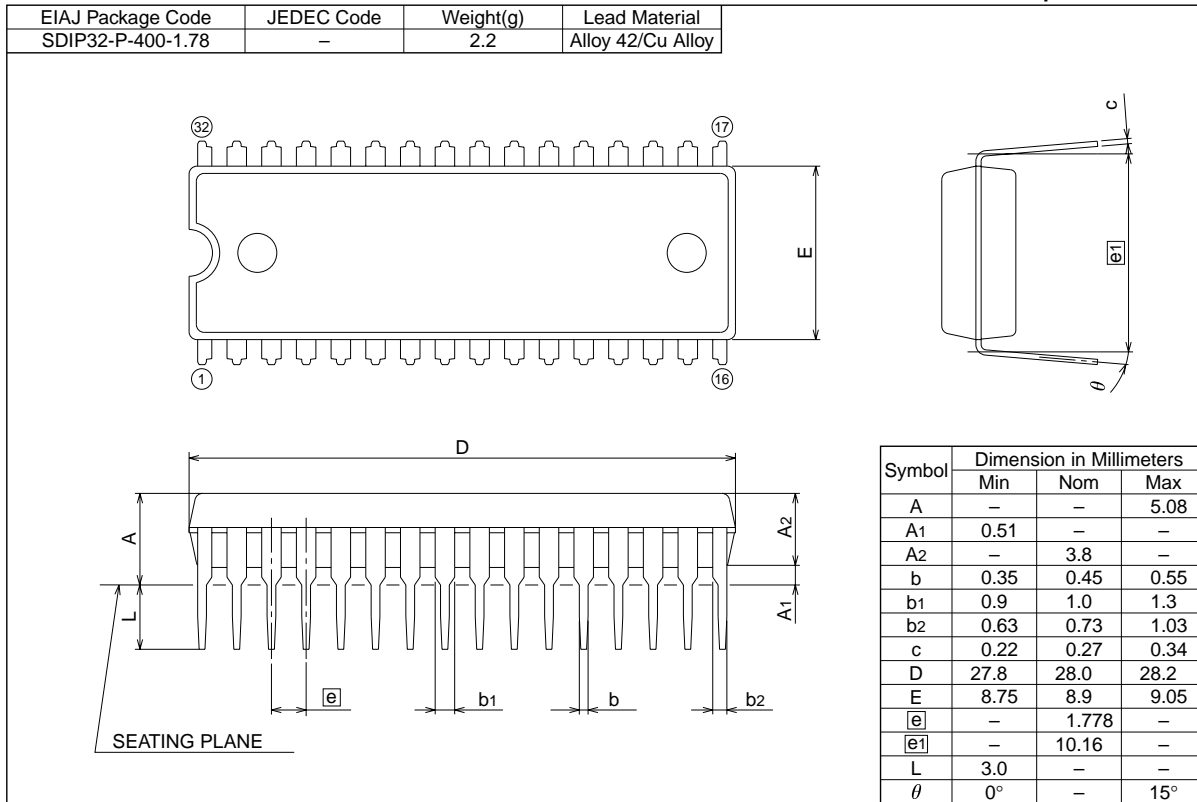

Keep safety first in your circuit designs!

- Mitsubishi Electric Corporation puts the maximum effort into making semiconductor products better and more reliable, but there is always the possibility that trouble may occur with them. Trouble with semiconductors may lead to personal injury, fire or property damage. Remember to give due consideration to safety when making your circuit designs, with appropriate measures such as (i) placement of substitutive, auxiliary circuits, (ii) use of non-flammable material or (iii) prevention against any malfunction or mishap.

Notes regarding these materials

- These materials are intended as a reference to assist our customers in the selection of the Mitsubishi semiconductor product best suited to the customer's application; they do not convey any license under any intellectual property rights, or any other rights, belonging to Mitsubishi Electric Corporation or a third party.
- Mitsubishi Electric Corporation assumes no responsibility for any damage, or infringement of any third-party's rights, originating in the use of any product data, diagrams, charts or circuit application examples contained in these materials.
- All information contained in these materials, including product data, diagrams and charts, represent information on products at the time of publication of these materials, and are subject to change by Mitsubishi Electric Corporation without notice due to product improvements or other reasons. It is therefore recommended that customers contact Mitsubishi Electric Corporation or an authorized Mitsubishi Semiconductor product distributor for the latest product information before purchasing a product listed herein.
- Mitsubishi Electric Corporation semiconductors are not designed or manufactured for use in a device or system that is used under circumstances in which human life is potentially at stake. Please contact Mitsubishi Electric Corporation or an authorized Mitsubishi Semiconductor product distributor when considering the use of a product contained herein for any specific purposes, such as apparatus or systems for transportation, vehicular, medical, aerospace, nuclear, or undersea repeater use.
- The prior written approval of Mitsubishi Electric Corporation is necessary to reprint or reproduce in whole or in part these materials.
- If these products or technologies are subject to the Japanese export control restrictions, they must be exported under a license from the Japanese government and cannot be imported into a country other than the approved destination.
 - Any diversion or reexport contrary to the export control laws and regulations of Japan and/or the country of destination is prohibited.
- Please contact Mitsubishi Electric Corporation or an authorized Mitsubishi Semiconductor product distributor for further details on these materials or the products contained therein.

REVISION HISTORY

7540 Group DATA SHEET

Rev. No.	Revision Description	Rev. date
1.0	First Edition	991122