



3 STATES ENCODER
3 态编码 IC

M3E,

GENERAL DESCRIPTION 功能叙述

The M3E, is a CMOS ASIC decoder. It will en-code 12 parallel input and serially transmit them to the output when \overline{TE} depressed. These address inputs are 3 states i.e. LOW(0)、OPEN(X)、HIGH(1).

FEATURES 产品特长

- Same Rosc matched to the DECODER M3D / DA / F
- Built-in IR carrier: suffix-IR.
- $3^{12} = 531,411$ codes, "0"、"X"、"1" Tri-states.
- 4 cycles transmission each time.
- Direct data transmit type : (Elimination \overline{TE} and diodes)
 - M3E,-H: switch to VDD.
 - M3E,-L: switch to VSS.

APPLICATIONS 产品应用

- Car/home alarm system, garage control etc..

BLOCK DIAGRAM 功能方块图

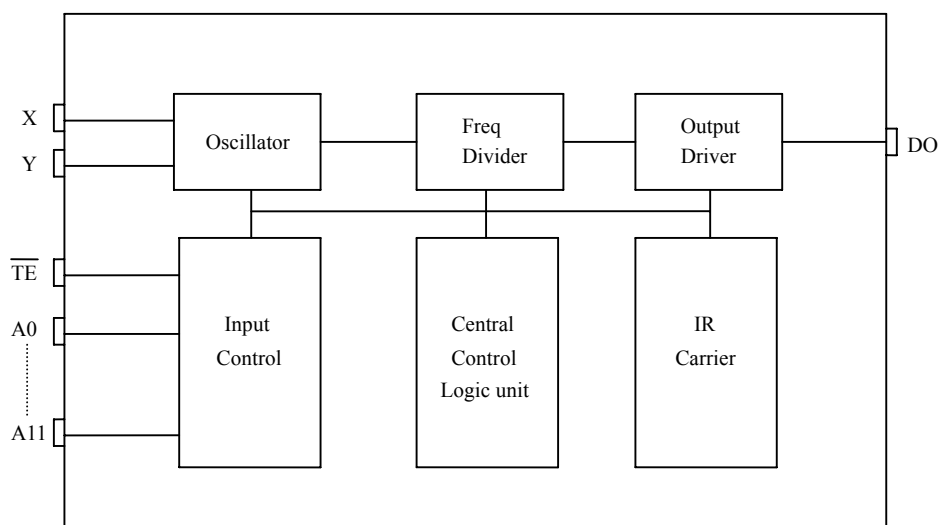

*All specs and applications shown above subject to change without prior notice.

(以上电路及规格仅供参考,本公司得径行修正)



3 STATES ENCODER
3 态编码 IC

EN/DECODER

M3E,

ABSOLUTE MAXIMUM RATING

(TA=25°C)

Parameter	Rating	Unit
Supply Voltage	-0.3 to 12	V
Input Voltage	-0.2~V _{DD} +0.2	V
Operating Temperature	-20 to 70	°C
Storage Temperature	-50 to 125	°C

ELECTRICAL CHARACTERISTICS

Characteristics	Sym.	Min.	Typ.	Max.	Unit	Conditions
Operating Voltage	V _{DD}	2.4	—	12	V	
Operating Current	I _{OP}	—	0.1	1	mA	No load
Quiescent Current	I _{SB}	—	0.1	0.5	μ A	
Output Drive Current	I _O	—	2	—	mA	@V _{DS} =1.2V
Input Voltage	V _{IH}	V _{DD} -0.2	V _{DD}	V _{DD}	V	
	V _{IL}	V _{SS}	V _{SS}	V _{SS} +0.2		
Oscillator Frequency	Fosc	—	76	—	KHz	External ±
						30%

PIN DESCRIPTION

No.	M3E,	Description
1~8	A0~A7	3 states address inputs
9	VSS	Negative power supply
10~13	A8~A11 / D0~D3	3 states address inputs / Data input
14	$\overline{\text{TE}}$	Transmit enable
15	Y	Oscillator output
16	X	Oscillator input
17	DO	Data output
18	VDD	Positive power supply

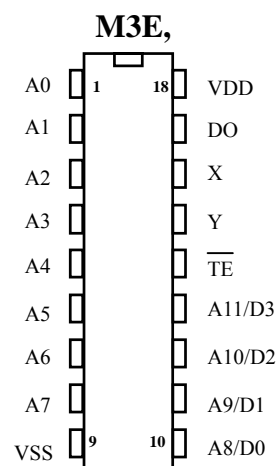



3 STATES ENCODER
3 态编码 IC

M3E,

TIMING WAVEFORM

(1) Bit Format

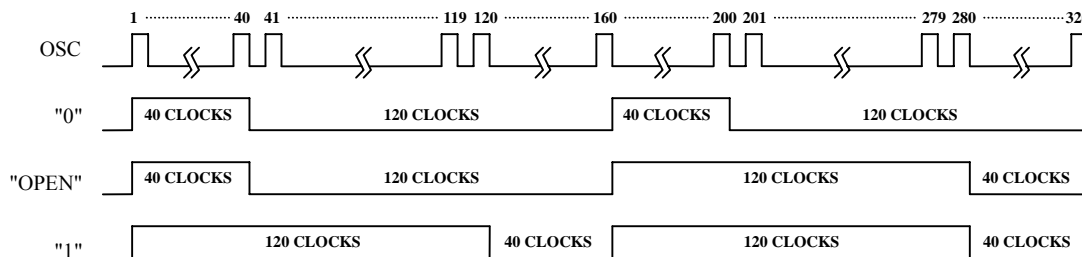

(2) TIMING DIAGRAM

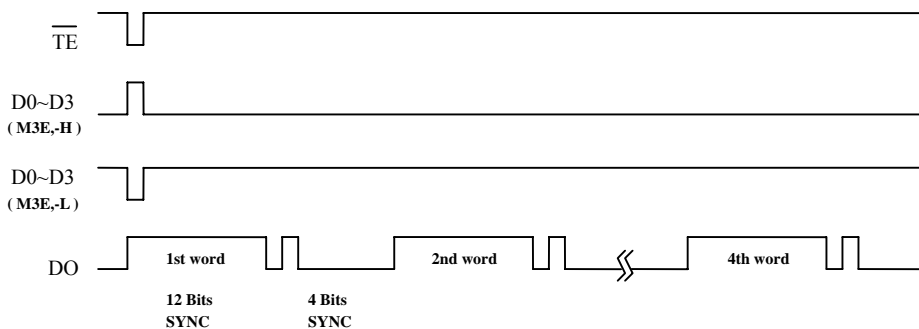

M3E, F-V Curve

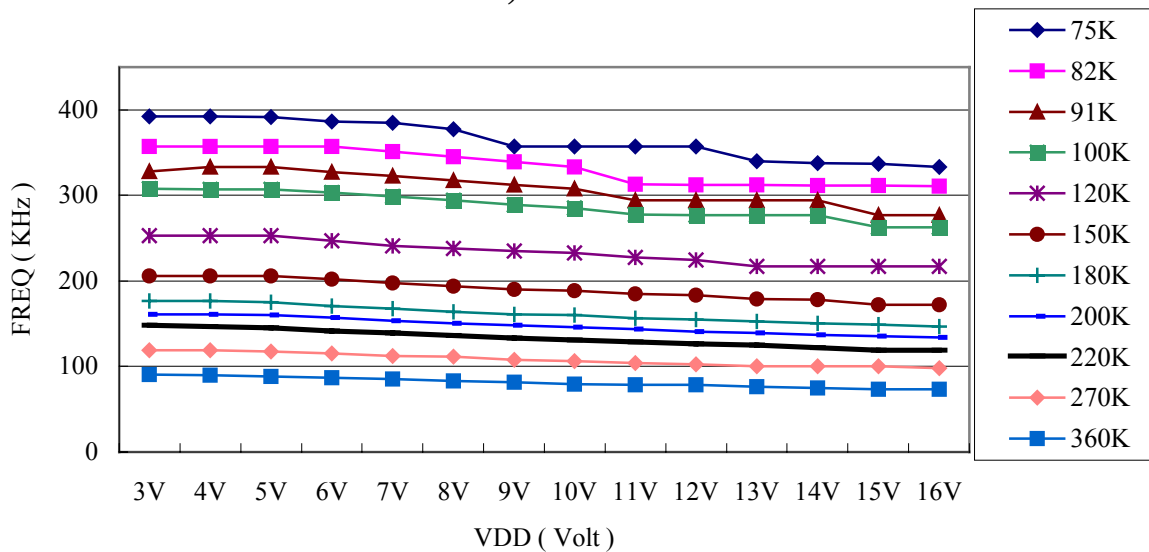



EN/DECODER
M3E,

OPERATING FLOWCHART

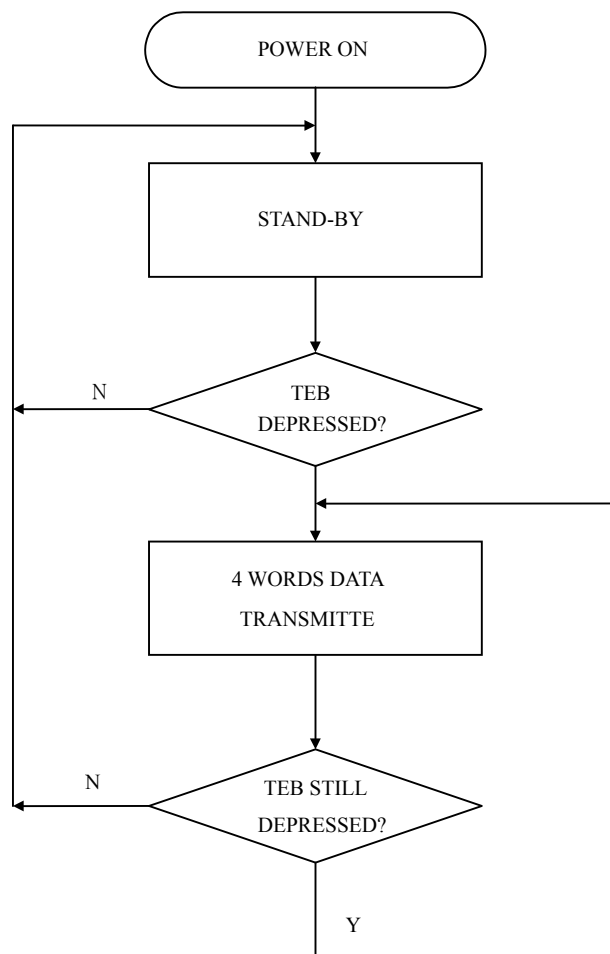



3 STATES ENCODER
3 态编码 IC

EN/DECODER

M3E,

RECONNENDED OSCILLATOR PARAMETERS

Rosc (KΩ)	M3E, (KHz)
75	357
82	312
91	294
100	277
120	225
150	184
180	155
200	141
220	127
270	103
360	78

DATA OUTPUT

M3E, (D0~D3)	M3D/F (D0~D3)
0 (VSS)	0 (VSS)
X (OPEN)	1 (VDD)
1 (VDD)	1 (VDD)
POWER ON	0 (VSS)

Freq-Rosc Chart
(@Vdd=12V)

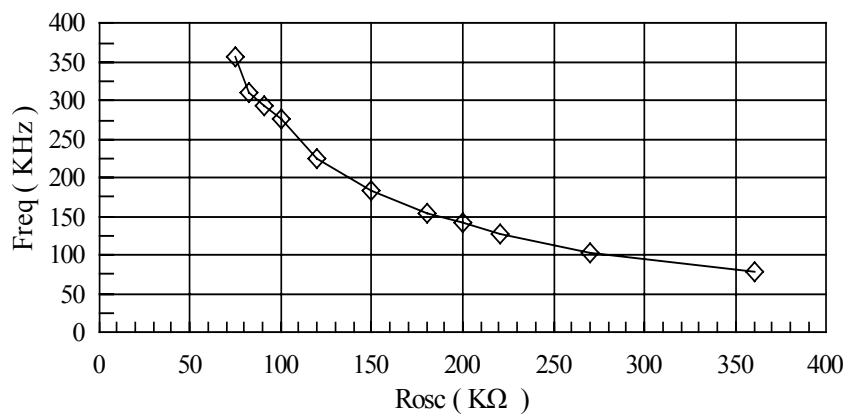

M3E,

◇ M3E/D/F



APPLICATION DIAGRAM 参考电路图

IR 内建发射

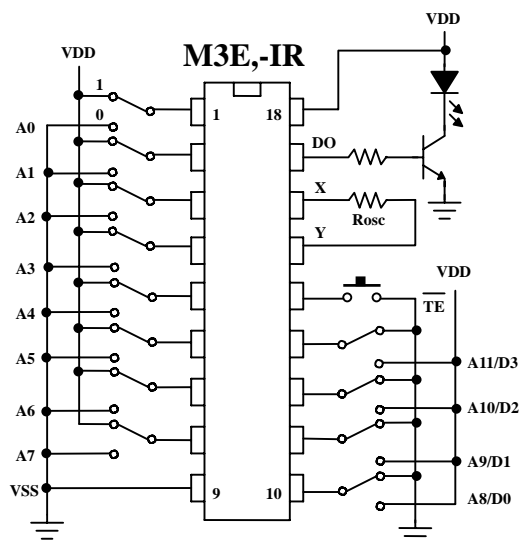
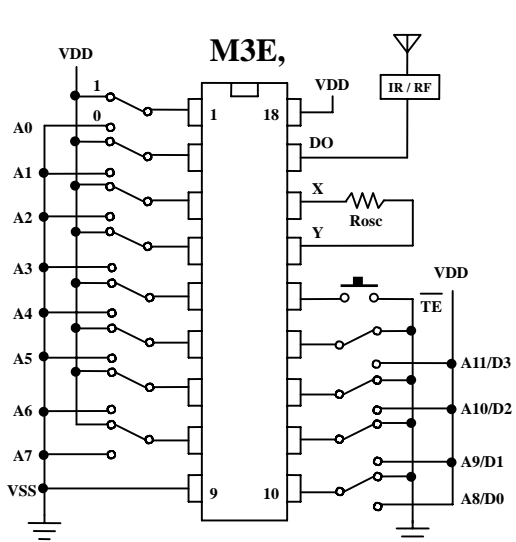

Rosc = 430KΩ @ V_{DD} = 4.5V

直接发射 (VDD)

直接发射 (VSS)

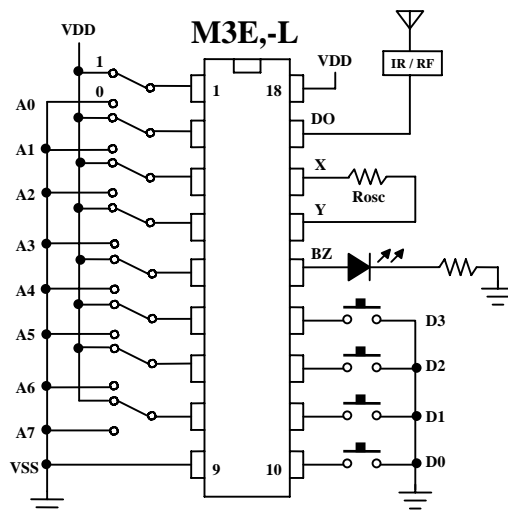
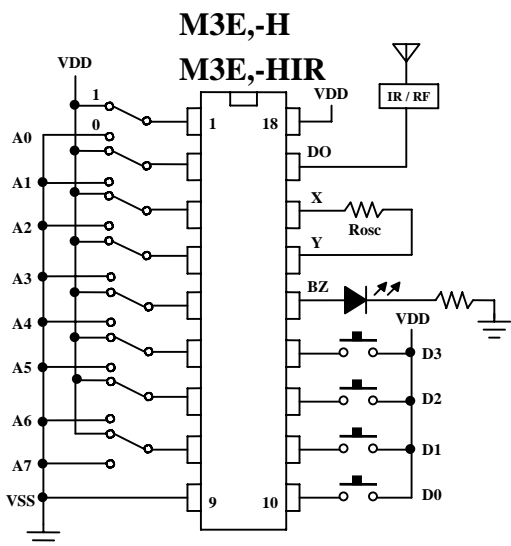

M3E,-HIR : Rosc = 430KΩ @ V_{DD} = 4.5V



APPLICATION DIAGRAM 参考电路图 (SOP PACKAGE)

IR 内建发射

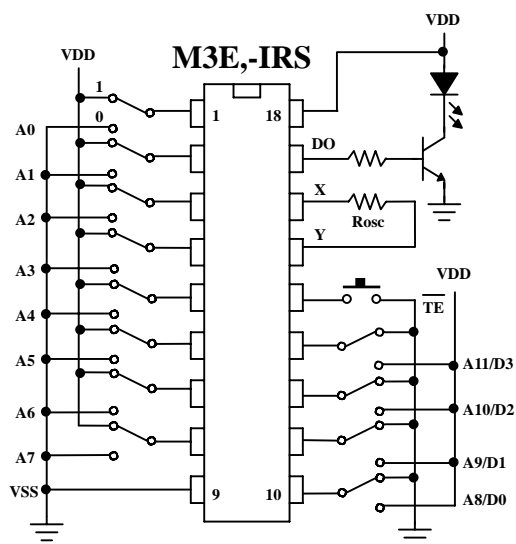
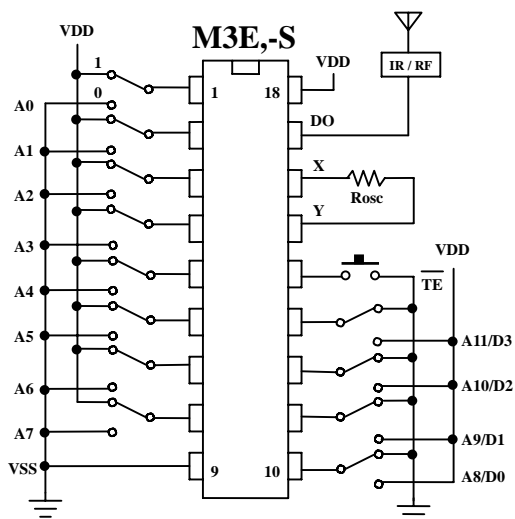

Rosc = 430KΩ @ V_{DD} = 4.5V

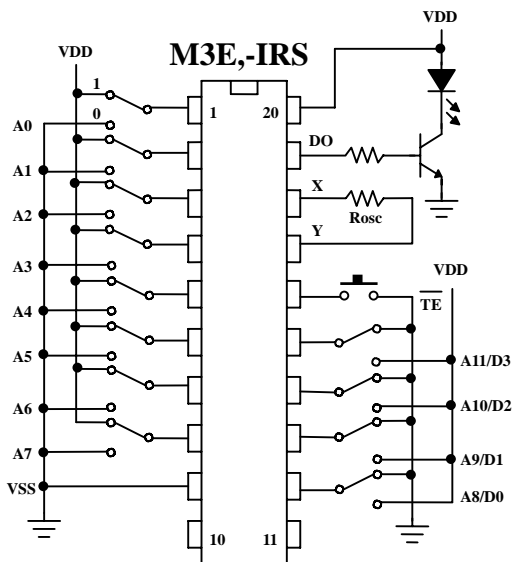
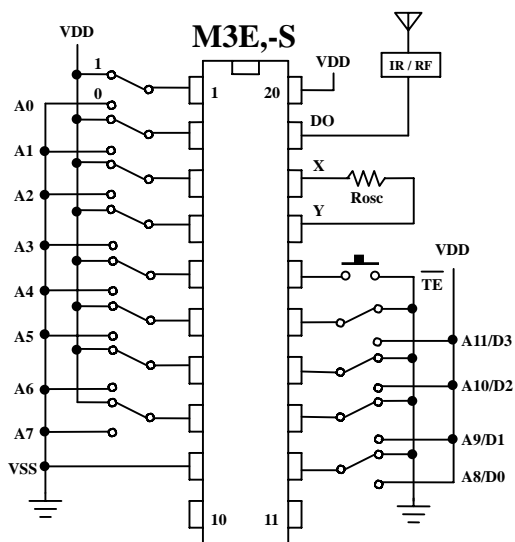

Rosc = 430KΩ @ V_{DD} = 4.5V



3 STATES ENCODER

3 态编码 IC

M3E,

APPLICATION DIAGRAM 参考电路图 (SOP PACKAGE)

直接发射 (VDD)

直接发射 (VSS)

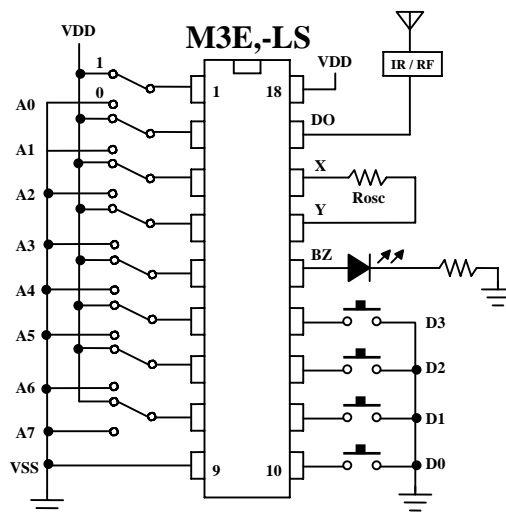
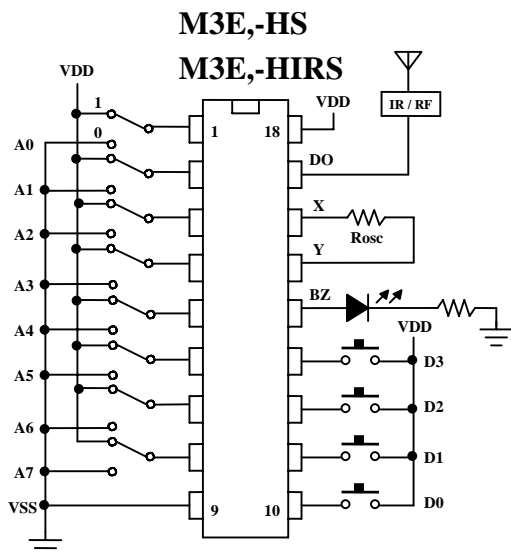

M3E,-HIRS : Rosc = 430KΩ @V_{DD} = 4.5V

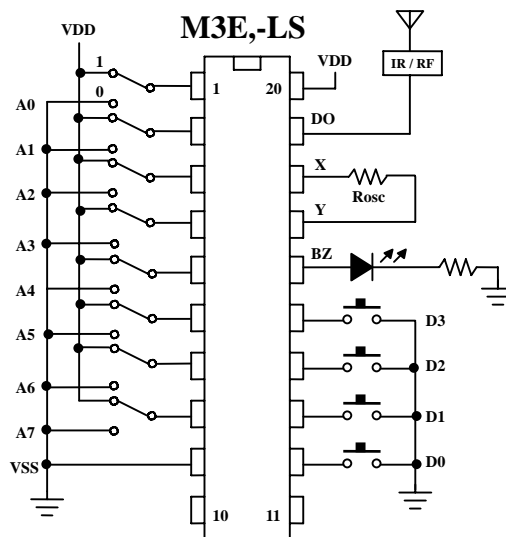
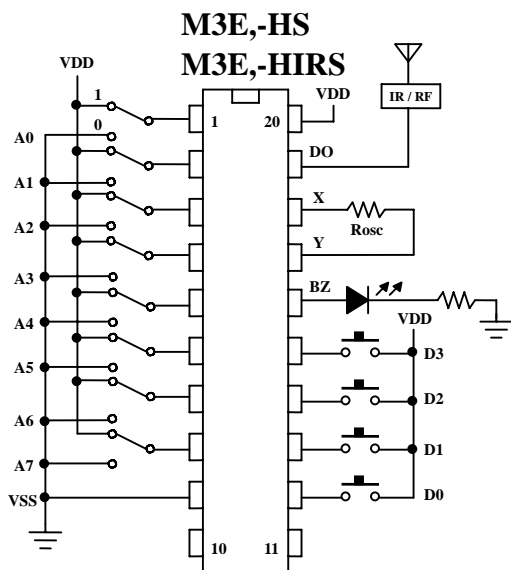

M3E,-HIRS : Rosc = 430KΩ @V_{DD} = 4.5V