

## Surface Mount Rectifiers

## M3F--M7F

### Features

- For surface mounted applications
- Low profile package
- Low forward voltage drop
- High surge current capability
- RoHS Compliant



### Mechanical Data

- Case: SMAF molded plastic
- Molding compound, UL flammability classification rating 94V-0
- Terminals: Solder plated, solderable per MIL-STD-202, Method 208
- Polarity: Color band denotes cathode end

### Maximum Ratings (@T<sub>A</sub> = 25°C unless otherwise specified)

Characteristic	Symbol	M3F	M4F	M5F	M6F	M7F	Units
Peak repetitive reverse voltage	V <sub>RRM</sub>	200	400	600	800	1000	V
RMS reverse voltage	V <sub>RMS</sub>	140	280	420	560	700	V
DC blocking voltage	V <sub>DC</sub>	200	400	600	800	1000	V
Maximum average forward output current	I <sub>F(AV)</sub>	1.0					A
Peak forward surge current, 8.3ms single half-sine-wave	@T <sub>J</sub> = 25°C I <sub>FSM</sub>	30					A

### Thermal Characteristics

Parameter	Symbol	M3F	M4F	M5F	M6F	M7F	Units
Typical thermal resistance (Note 1)	R <sub>θJA</sub>	78					°C /W
	R <sub>θJC</sub>	18					
	R <sub>θJL</sub>	20					
Operating junction temperature range	T <sub>J</sub>	- 55 ---- + 150					°C
Storage temperature range	T <sub>STG</sub>	- 55 ---- + 150					°C

Note:

1. Device mounted on PCB with 10 mm x 20 mm x 0.1mm copper pad areas

# Surface Mount Rectifiers

## M3F--M7F

### Electrical Characteristics (@T<sub>A</sub> = 25°C unless otherwise specified)

Parameter	Symbol	Test conditions		Typ.	Max.	Units
Maximum instantaneous forward voltage	V <sub>F</sub>	I <sub>F</sub> =1.0A		--	1.1	V
Maximum Reverse current	I <sub>R</sub>	Rated V <sub>R</sub>	@T <sub>A</sub> =25°C	--	5	μA
			@T <sub>A</sub> =125°C	--	50	

# Surface Mount Rectifiers

# M3F--M7F

## Ratings and Characteristic Curves ( $T_A=25^\circ\text{C}$ unless otherwise noted)

Fig.1-Forward Current Derating Curve

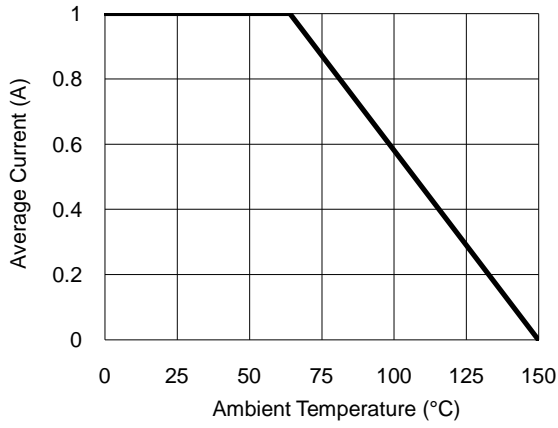

Fig.2- Surge Current Derating Curve

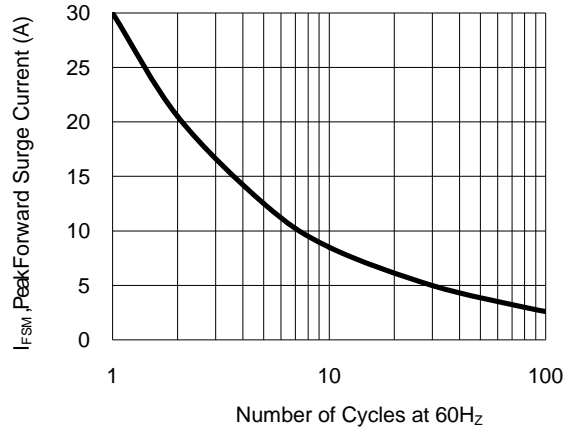

Fig.3- Typical Forward Voltage Characteristic

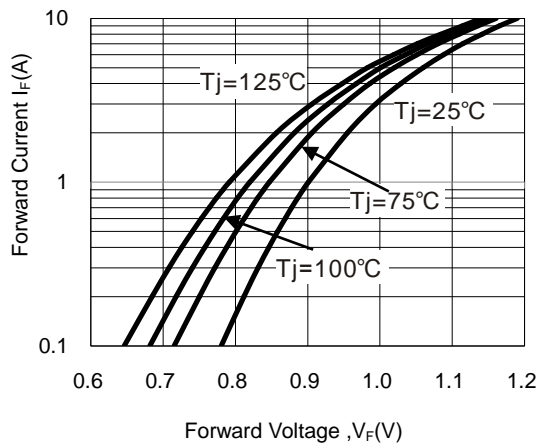
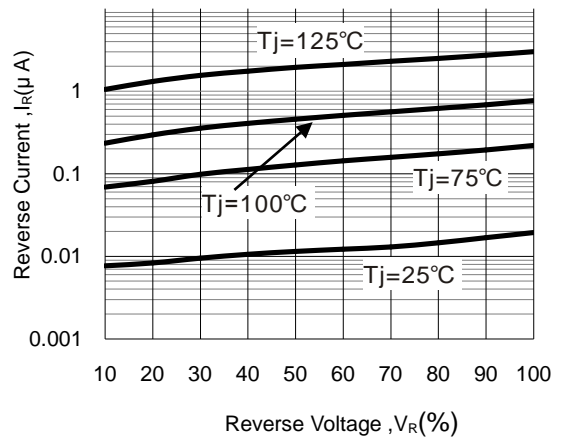

Fig.4- Typical Reverse Characteristic



## Surface Mount Rectifiers

M3F--M7F

### Package Outline Dimensions(unit:mm)

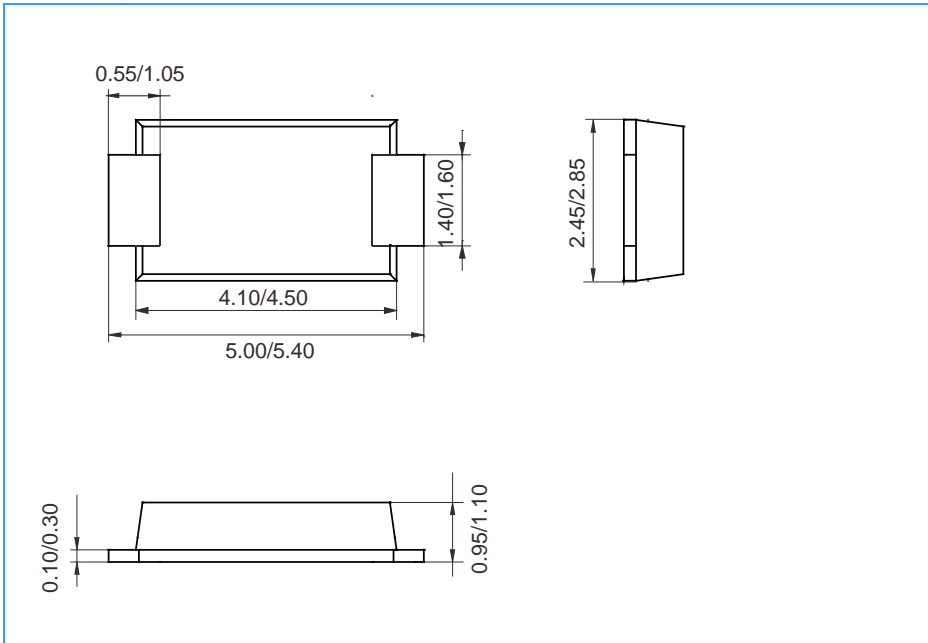

### Mounting Pad Layout(unit:mm)

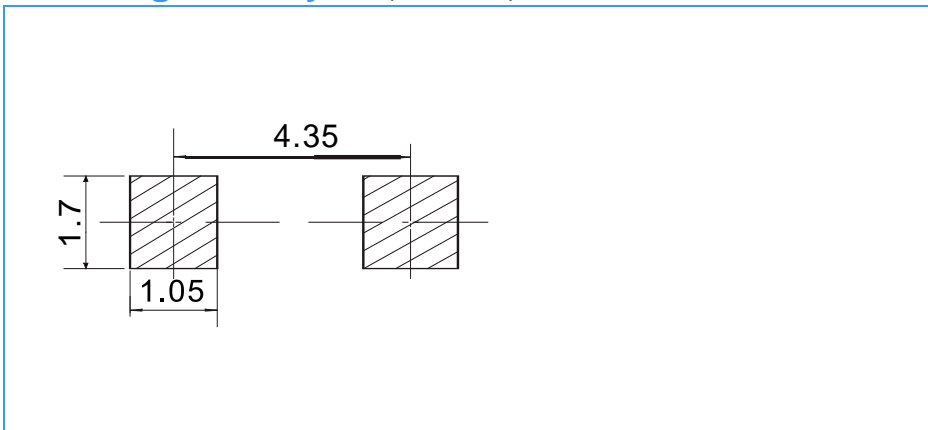

### Ordering Information

Part No.	Marking	Package	Shipping
M3F	M3F	SMAF	10000 /Tape&Reel
M4F	M4F	SMAF	10000 /Tape&Reel
M5F	M5F	SMAF	10000 /Tape&Reel
M6F	M6F	SMAF	10000 /Tape&Reel
M7F	M7F	SMAF	10000 /Tape&Reel