

M50427FP

CD PLAYER DIGITAL SIGNAL PROCESSOR

DESCRIPTION

The M50427FP is a CMOS IC developed for compact disc (CD) sound reproducing applications. It has adjustment-free PLL, error correction circuitry, etc. and is used in a CD digital signal processing section. Applications include also CD-ROM and CD-G, as well as CD-DA.

FEATURES

- Adjustment free EFM-PLL circuit (builtin VCO)
- ± 8 frames jitter margin
- Easy-to-handle CLV servo commands
- Subcode parallel/serial interface
- 2 times over sampling
- Capable of double speed sound reproduction

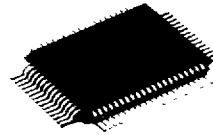

Outline 72P6-B

0.8mm pitch QFP
(18.0mm x 13.2mm x 2.0mm)

RECOMMENDED OPERATING CONDITIONS

Supply voltage range..... $V_{DD} = 4.5 \sim 5.5V$
 Rated voltage range..... $V_{DD} = 5V$
 Rated power dissipation..... 90mW

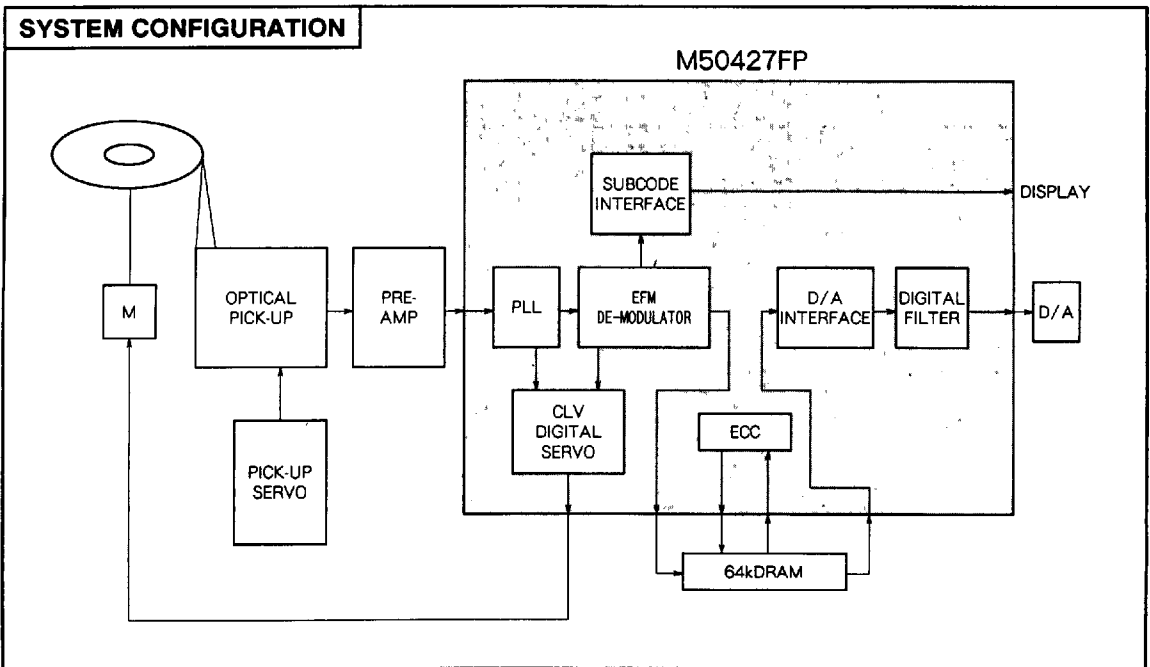

M50427FP

CD PLAYER DIGITAL SIGNAL PROCESSOR

PIN CONFIGURATION

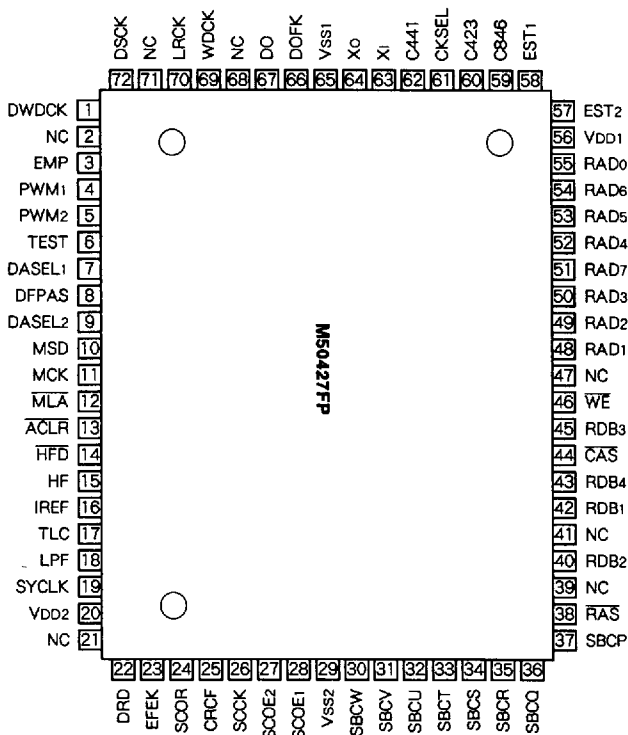

Outline 72P6-B

NC: NO CONNECTION

IC INTERNAL BLOCK DIAGRAM

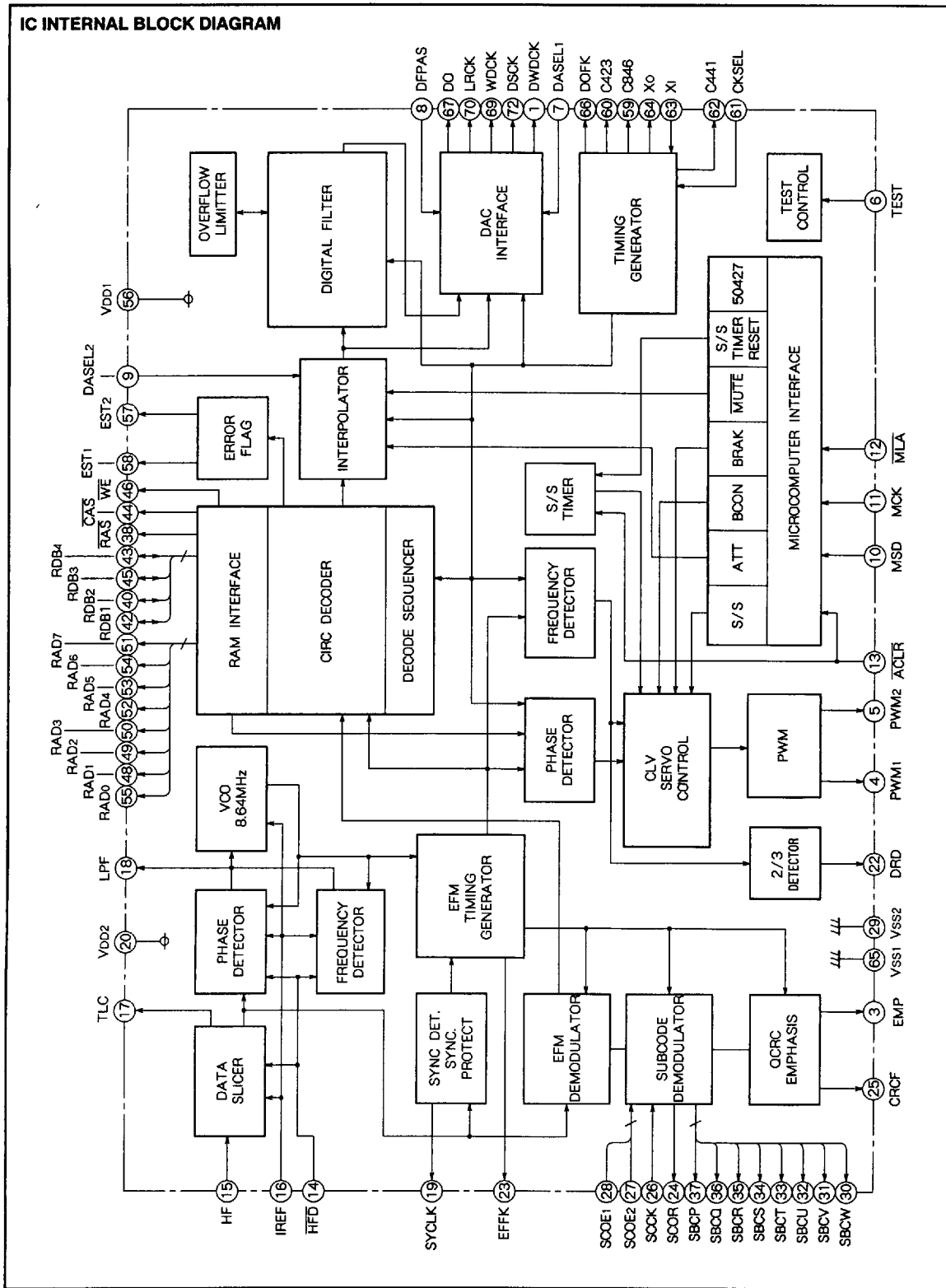

CD PLAYER DIGITAL SIGNAL PROCESSOR

PIN DESCRIPTION

Name	I/O	Function
DWDCK	O	Mode3 word clock to DAC
EMP	O	Emphasis flag output, Emphasis = 1
PWM ₁	O	Disc motor driving PWM output 1, -
PWM ₂	O	Disc motor driving PWM output 2, +
TEST	I	Test control input, Normal = 0
DASEL ₁	I	DAC interface format select 1
DFPAS	I	Digital filter pass select, Bypass = 1
DASEL ₂	I	DAC interface format select 2
MSD	I	Microcomputer interface serial data input
MCK	I	Microcomputer interface shift clock input
MLA	I	Microcomputer interface data latch clock input
ACL \bar{R}	I	Microcomputer interface register clear input, All clear = 0 SS timer reset = 1 MUTE, S/S, BCON = 0 become
HFD	I	High frequency detect
HF	I	High frequency input
IREF	I	Current reference
TLC	O	Output from slice level control
LPF	I/O	PLL loop filter
SYCLK	O	Frame lock status output, Lock = 1
V _{DD2}	I	V _{DD} for data slicer and VCO
DRD	O	Low disc rotation status
EFFK	O	EFM frame clock duty = 50%
SCOR	O	Subcode sync output So + S ₁
CRCF	O	Subcode Q, CRC check flag output CROCK = 1
SCCK	I	Shift clock input for serial subcode data output
SCOE ₂	I	Enable input of subcode T~Wch output 0: High Z
SCOE ₁	I	Enable input of subcode P~Sch output 0: High Z
V _{SS2}	I	Ground
SBCW	O	Subcode Wch output
SBCV	O	Subcode Vch output
SBCU	O	Subcode Uch output
SBCT	O	Subcode Tch output
SBCS	O	Subcode Sch output
SBCR	O	Subcode Rch output

Name	I/O	Function
SBCQ	O	Subcode Qch output
SBCP	O	Subcode Pch output Pch~Wch serial data output
RAS	O	Row address strobe output to RAM
RDB ₂	I/O	Data input/output 2 to RAM
RDB ₁	I/O	Data input/output 1 to RAM
RDB ₄	I/O	Data input/output 4 to RAM
CAS	O	Column address strobe output to RAM
RDB ₃	I/O	Data input/output 3 to RAM
WE	O	Write enable output to RAM
RAD ₁	O	Address output 1 to RAM
RAD ₂	O	Address output 2 to RAM
RAD ₃	O	Address output 3 to RAM
RAD ₇	O	Address output 7 to RAM
RAD ₄	O	Address output 4 to RAM
RAD ₅	O	Address output 5 to RAM
RAD ₆	O	Address output 6 to RAM
RAD ₀	O	Address output 0 to RAM
V _{DD1}	I	Power supply 5V
EST ₂	O	Error status 2, Error to be interpolated detected at C2 decoder = 1
EST ₁	O	Error status 2, Error detected at C1 decoder = 1
C846	O	Clock output 8.4672MHz
C423	O	Clock output 4.2336MHz, duty = 50%
CKSEL	I	Crystal selector input L = 8.4672MHz H = 16.9344MHz
C441	O	Clock output 44.1kHz (crystal = 16.9344MHz)
X _i	I	Crystal oscillator input with internal feedback resistor
X _o	O	Crystal oscillator output
V _{SS1}	I	Ground
DOFK	O	OSC frame clock output 7.35kHz, duty = 50%
DO	O	Serial data output to DAC
WDCK	O	Word clock to DAC or APTL clock
LRCK	O	Lch/Rch clock to DAC or APTL clock
DSCK	O	Data shift clock to DAC

CD PLAYER DIGITAL SIGNAL PROCESSOR

ABSOLUTE MAXIMUM RATINGS (Ta = 25°C, unless otherwise noted)

Symbol	Parameter	Conditions	Ratings	Unit
V _{DD-VSS}	Supply voltage		- 0.3~+ 7.0	V
V _I	Input voltage	(R _P = 0 Ω)	V _{SS} -0.3 ≤ V _I ≤ V _{DD} +0.3	V
V _O	Output voltage	(R _P = 0 Ω)	V _{SS} -0.3 ≤ V _O ≤ V _{DD}	V
V _P	Pull up voltage		V _P ≤ V _{DD} + 2mA * R _P	V
T _{opr}	Operating temperature		-10~+70	°C
T _{stg}	Storage temperature		-40~+125	°C
P _d	Power dissipation		350	mW

RP : Pulling up resistor

RECOMMENDED OPERATING CONDITIONS

Symbol	Parameter	Test conditions	Applied pin	Limits			Unit
				Min	Typ	Max	
V _{DD}	Supply voltage			3.5	5.0	5.5	V
V _{IH1}	High-level input voltage 1		2)	V _{DD} * 0.5	-	V _{DD}	V
V _{IH2}	High-level input voltage 2		1)	V _{DD} * 0.7	-	V _{DD}	V
V _{IL1}	Low-level input voltage 1		2)	V _{SS}	-	V _{DD} * 0.08	V
V _{IL2}	Low-level input voltage 2		1)	V _{SS}	-	V _{DD} * 0.3	V
f _{osc}	Oscillation frequency (X'tal)			-	8.46	-	MHz
f _{vco}	Oscillation frequency (VCO)			-	8.64	-	MHz

Note 1. Applied pin

- 1) DASEL1, DFPAS, DASEL2, CKSEL, TEST
- 2) HFD, SCOE1, SCOE2, SCCK, MSD, MCK, MLA, ACLR, RDB1~RDB4

ELECTRICAL CHARACTERISTICS (Ta = 25°C, V_{DD} = 5V, unless otherwise noted)

Symbol	Parameter	Test conditions	Applied pin	Test circuit	Limits			Unit
					Min	Typ	Max	
V _{DD}	Supply voltage	Ta = - 10~+ 70°C		1	3.5	5.0	5.5	V
I _{DD}	Circuit current	f _{osc} = 8.4672MHz f _{vco} = 8.6436MHz		2	-	15	30	mA
V _{OH}	High-level output voltage	V _{DD} =4.5V, I _{OH} = -0.8mA	3)	3	3.5	-	-	V
V _{OL}	Low-level output voltage	V _{DD} =4.5V, I _{OL} =0.8mA	3)	3	-	-	0.4	V
I _{IH}	High-level input current	V _{IH} =4.5V	4)	4	-	-	2	μA
I _{IL}	Low-level input current	V _{IL} =0.5V	4)	4	-	-	- 2	μA
I _{ozH}	Off state high-level output current	V _{OH} =4.5V	5)	5	-	-	2	μA
I _{ozL}	Off state low-level output current	V _{OL} =0.5V	5)	5	-	-	- 2	μA
f _{vco1}	VCO (EFFK)	V _{LPF} = 1.0V		6	-	-	3.0	kHz
f _{vco2}		V _{LPF} = 2.5V		6	8.0	10.0	-	kHz
f _{vco3}	Free running frequency	V _{LPF} = 4.0V		6	11.0	-	-	kHz

Note 2. Applied pin

- 3) Output and input/output pin except Xo, TLC, LPF
- 4) Input pin except Xi, IREF
- 5) RDB1~RDB4, SBCP~SBCW

TEST CIRCUIT

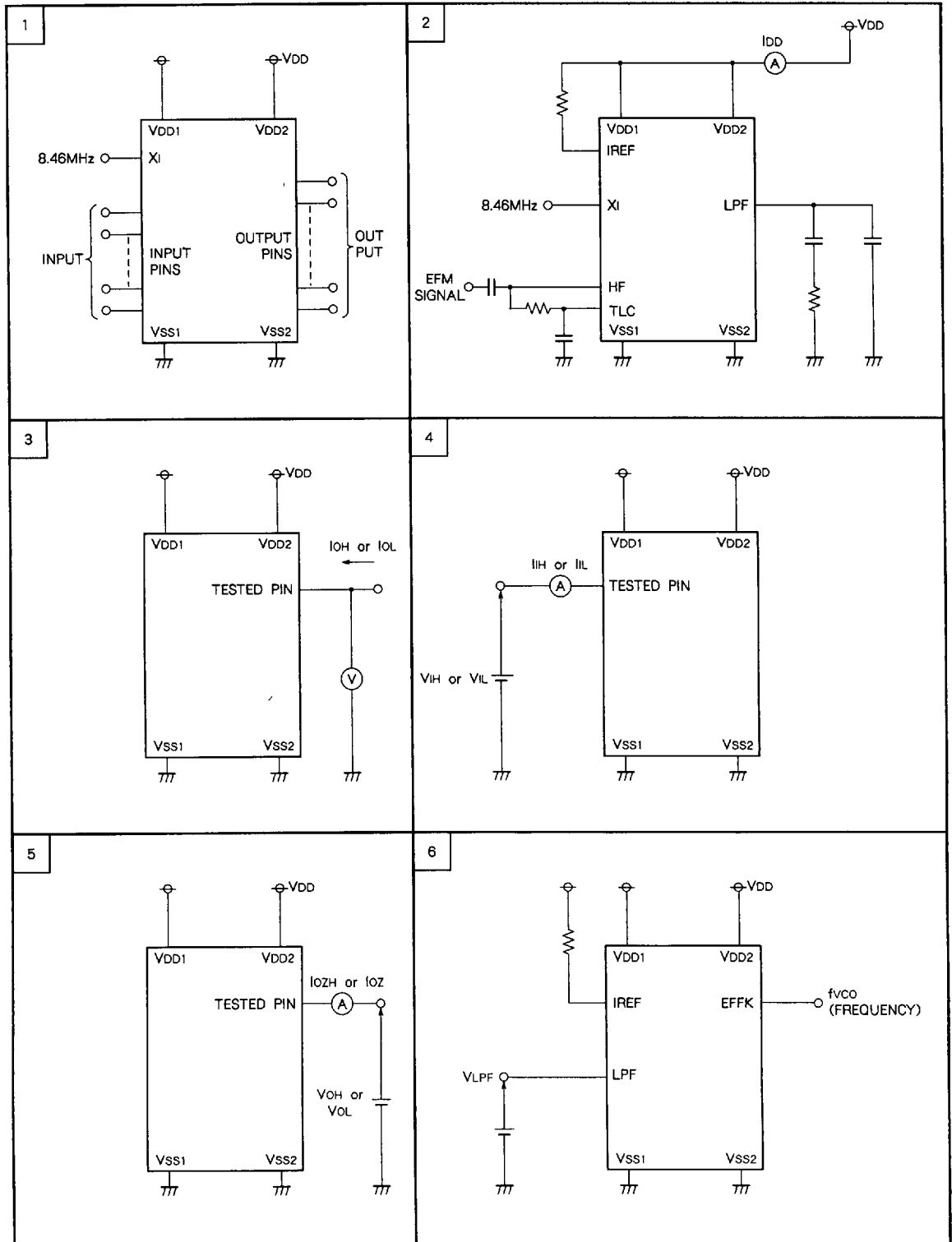

FUNCTIONAL DESCRIPTION

1. Data slicing/PLL

The M50427FP has an analog front-end for incoming EFM (HF) signal. Using CMOS-Analog technology, the front-end comprises an automatic slice level control circuit and EFM-PLL circuit with internal adjust-free VCO. The HF signal is sliced by the HF comparator and a DC level is feed back from TLC to HF through the external CR. If HFD goes High because of a defect an disc, then TLC frms off and holds the DC level. The block-diagram shows the analog front-end.

EFM-PLL extracts the EFM clock signal from the HF signal. The PLL circuit has a phase/frequency comparator providing

the M50427FP with a wide capture/lock range. There is no need to adjust the VCO. LPF is the charge-pump output and same-time control voltage input to the VCO. LPF frms off state if HFD goes high.

IREF is the reference current input used to determine the current of charge pumps of TLC and LPF, operating point of HF comparator and VCO free running frequency. If IREF is connected to a noisy power supply through a resistor, VCO is modulated and the error-rate increases. Therefore, power supply noise at IREF must be held to a minimum.

BLOCK DIAGRAM (Data slicing/PLL)

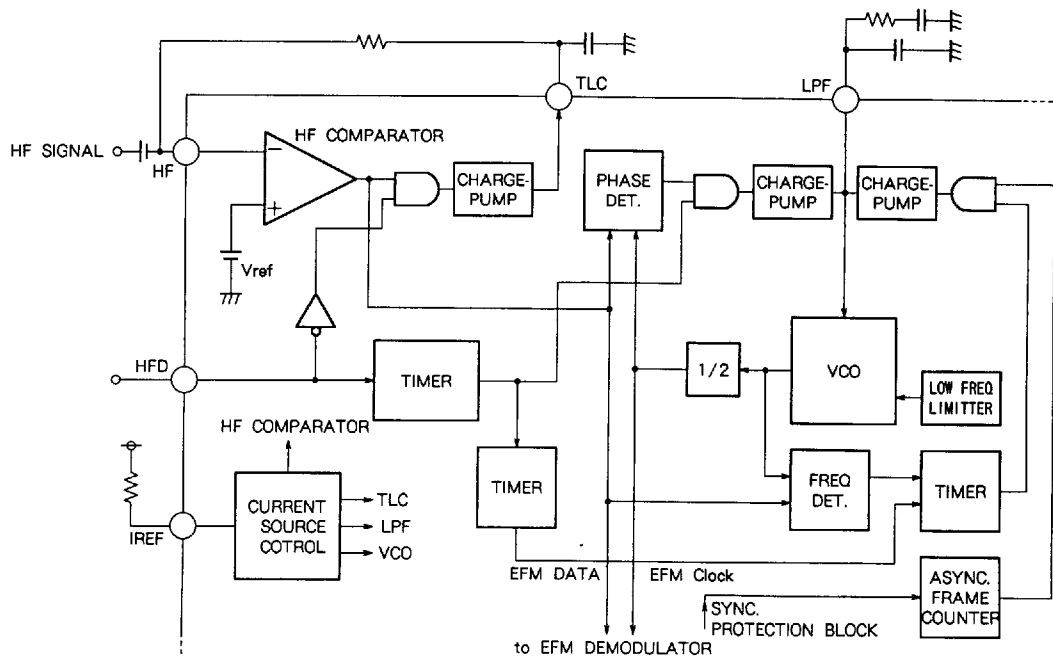

M50427FP

CD PLAYER DIGITAL SIGNAL PROCESSOR

(1) Automatic slice level control

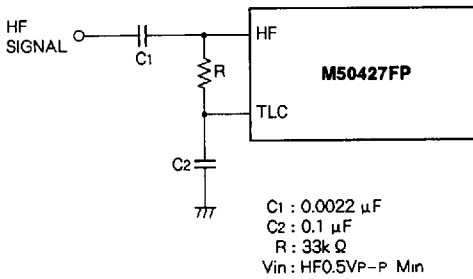

The slice level control circuit is formed by connecting a resistor and capacitors to the HF (High-Frequency signal input) pin and TLC (slice level control output) pin.

(2) PLL

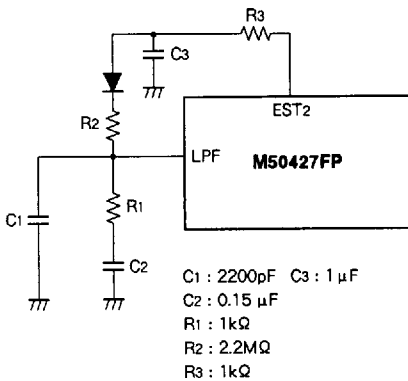

Since the adjustment-free VCO is built in, the adjustment-free PLL circuit can be formed by connecting a resistor and capacitors to the LPG (low-pass filter) pin.

(3) Reference current

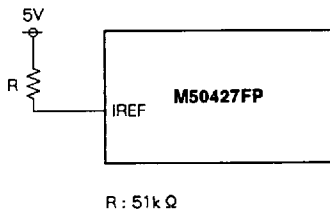

Connect the resistor between the IREF pin and V_{DD} to set the reference current that determines the current values of the TLC pin and LPG pin, the comparator operating current of the slice level control circuit and the VOC free-run frequency.

2. Demodulation/Decoding

(1) Clock generator

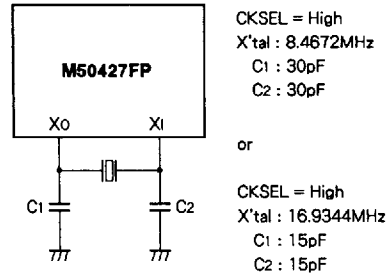

(a) The oscillation circuit can be formed by connecting the X'tal oscillator (8.4672MHz or 16.9344MHz) and load capacitors to pins X_1 and X_0 .

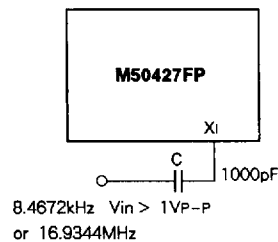

b) When the system contains a clock (8.4672MHz or 16.9344MHz), the clock can be input to pin X_1 via a capacitor without using the X'tal oscillator. If the input signal is the logical level, the capacitor is not necessary.

(2) Frame Synchronization

The EFM signal is demodulated by synchronizing the demodulation circuit at frame level. The block diagram shows this frame synchronization control part.

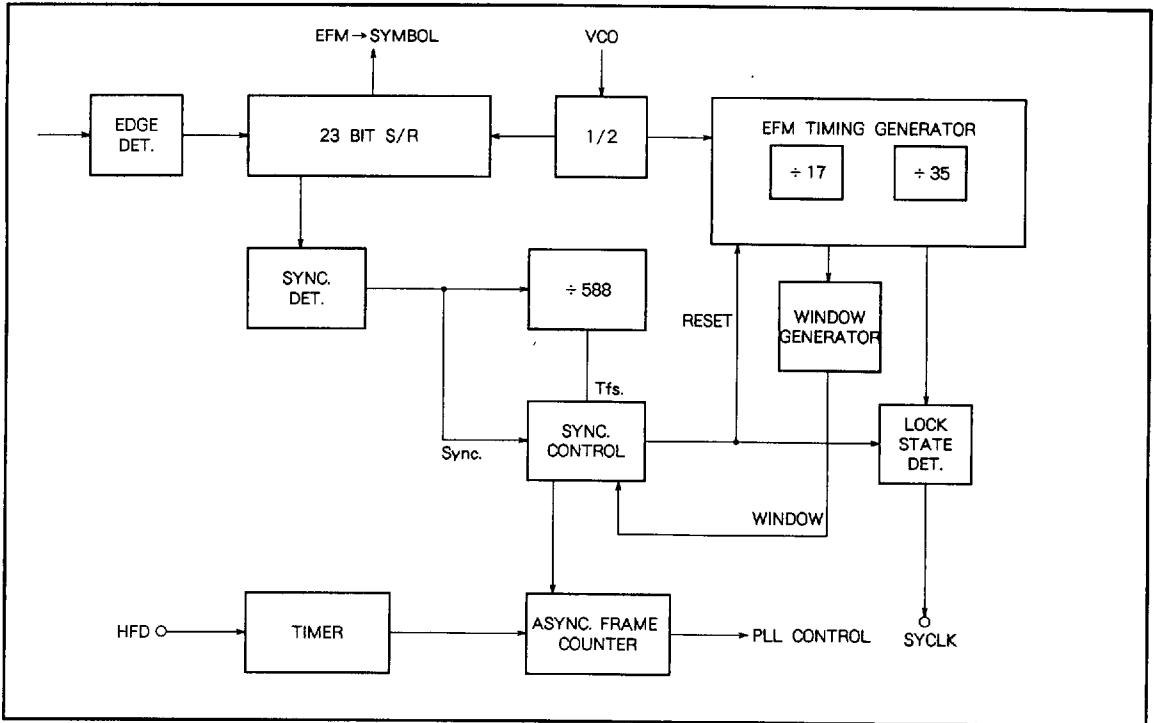

Fig. 1 Frame synchronization block diagram

The generating condition of the counter reset signal (Reset) in the EFM timing generator part is indicated as follows :

$$\text{Reset} = \text{Sync} * \text{Tfs} + \text{Sync} * \text{Window}$$

* : Logical product

+ : Logical sum

Sync. : Synchronizing signal

Tfs : Detection signal of synchronizing signal space = 588

Window : Window signal $\pm 7ck$

In the synchronous state, Sync and Tfs generate simultaneously and Sync comes to the center of the window. At this time, 1 is output to the SYCLK pin.

(3) Subcode demodulation

Among data converted from 14-bit EFM signals to 8-bit symbols, subcode P, Q, R, S, T, U, V and W are output to pins SBCP - SPCW respectively. When the subcode synchronizing patterns S0 or S1 are detected as the synchronizing signals of the subcode data, the synchronizing signal are output to the SCOR pin. The pins SBCP-SBCW

are a Three-State output system and control the output by 4-bit through two external pins SCOE1 and SCOE2.

SUBCODE DEMODULATION

SCOE1	SCOE2	SBCP	SBCQ	SBCR	SBCS	SBC T	SBCU	SBCV	SBCW
0	0	High-impedance				High-impedance			
1	0	P	Q	R	S	High-impedance			
0	1	High-impedance				T	U	V	W
1	1	P	Q	R	S	T	U	V	W

A CRC check is made for the Q channel data and if the data is correct, 1 is output to the CRCF pin. Whether or not there is emphasis is output to the EMP pin. The subcode data is not only output in parallel but also can be obtained serially via pin SBCP by inputting a clock to pin SCKK.

Fig. 2 shows the timing of each signal.

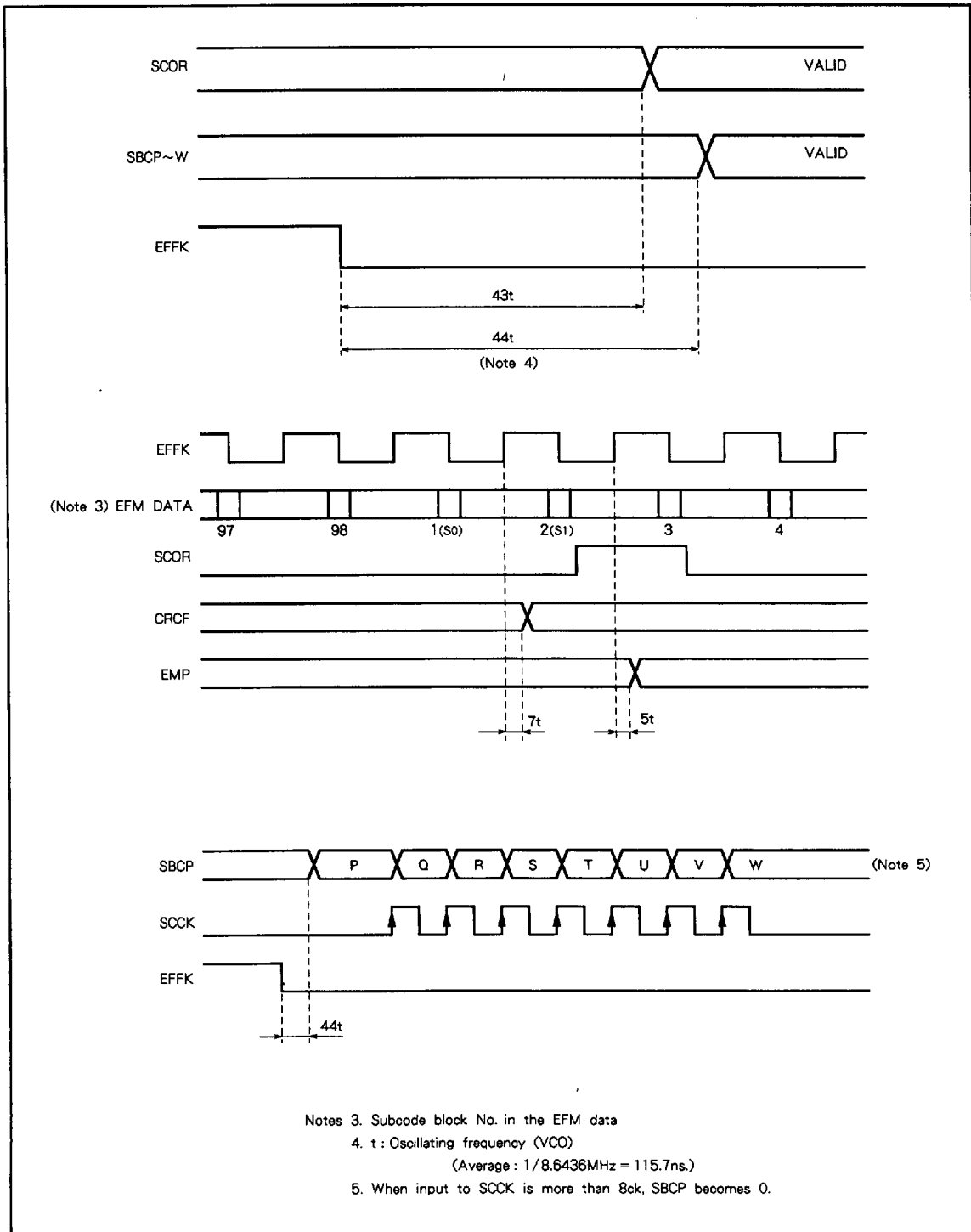

Fig. 2 Subcode output timing

CD PLAYER DIGITAL SIGNAL PROCESSOR

(4) RAM interface/CIRC decoding

A 64K/256K dynamic RAM is used as the external memory for temporary storage process CIRC decoding (C1 decoding, C2 decoding, unscramble and de-interleave) and output interpolation.

By using a 64K/256K RAM, jitter is absorbed up to ± 8 frames (max.).

Fig. 3 shows the timing for reading from and writing to the RAM.

In CIRC decoding, double error correction is done for both C1 and C2 decoding. When correction is not possible, average interpolation or pre-hold interpolation is performed. Error states which are detected during decoding are output to pins EST₁ and EST₂.

When an error is detected by C1 decoding, 1 is output to pin EST₁. When an error word is judged un-correctable by C2 decoding, 1 is output to pins EST₂.

The output timings for pins EST₁ and EST₂ are as follows:

Timing chart

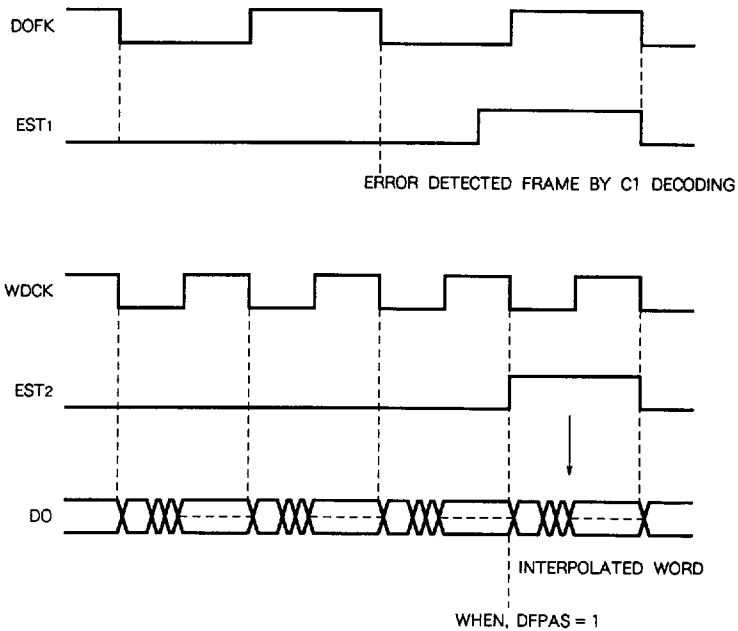

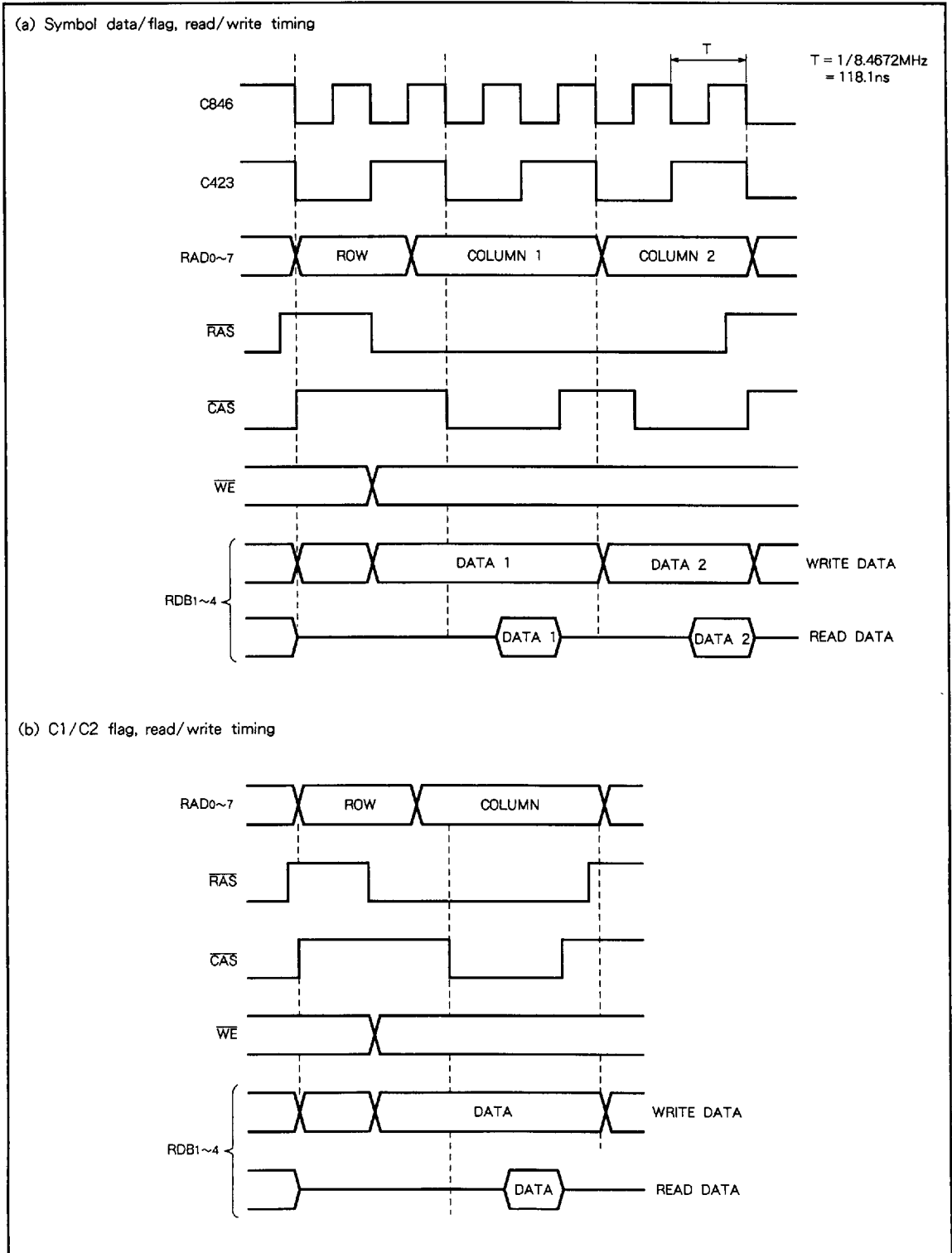
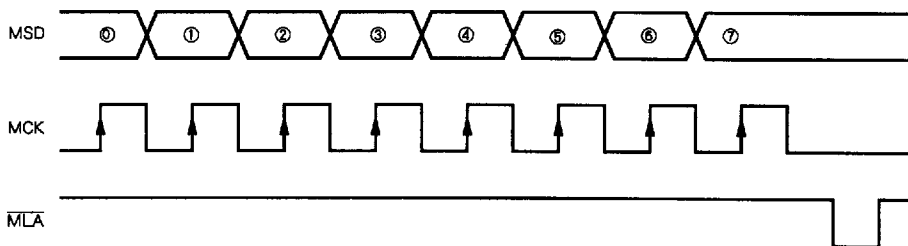

Fig. 3 RAM Interface timing

3. Microcomputer Interface

CLV servo, MUTE and ATT system control is done by serial command from the microcomputer. The timing, and names and functions of each control register are as follows :

Timing chart



- | | |
|--------------------------------|--------------|
| ⑩ DUMMY (Don't care) | X |
| ① S/S(START/STOP) register. | start = 1 |
| ② BCON(BRAKECONTROL) register. | enable = 1 |
| ③ BRAK(BRAKE) register. | brake = 1 |
| ④ ATT(ATTENUATE) register. | -12dB = 1 |
| ⑤ MUTE register. | mute = 0 |
| ⑥ S/S timer reset register. | reset = 1 |
| ⑦ IC code. | M50427FP = 1 |

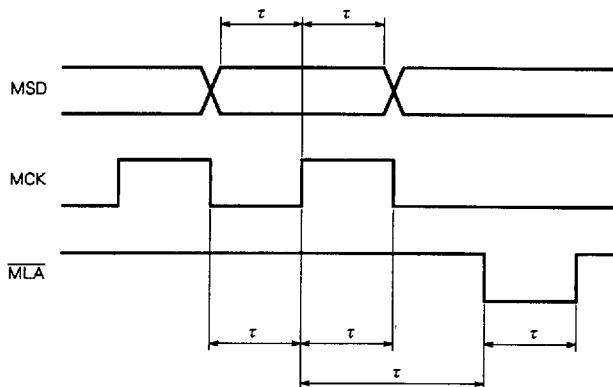

τ min * 500ns

M50427FP

CD PLAYER DIGITAL SIGNAL PROCESSOR

Function of interface resistors

Register No.	Register name	Function	Operation		Note
			0	1	
①	DUMMY	Don't care	-	-	
①	S/S (START/STOP)	Controls START/STOP of the disk motor	DISC MOTOR STOP (OFF)	DISC MOTOR START (ON)	0 by $\overline{ACL\overline{R}}$
②	BCON (BRAKECONTROL)	Determines if BRAKE control is necessary	BRAKE 0.3sec.	BRAKE is controlled by BRAK register	0 by $\overline{ACL\overline{R}}$
③	BRAK (BRAKE)	Controls BRAKE	BRAKE OFF (MOTOR OFF)	BRAKE ON	When BCON = 1
④	ATT (ATTENUATE)	Sets attenuation (-12dB)	0dB	-12dB	When MUTE = 1
⑤	MUTE	Sets the muting	$-\infty$ dB	0dB	0 by $\overline{ACL\overline{R}}$
⑥	S/S timer reset	Resets the S/S timer which sets the time of KICK and BRAKE to 0.3sec	S/S timer enable	S/S timer disable	1 by $\overline{ACL\overline{R}}$
⑦	IC code	Distinguishes the command to the M50427FP	-	Executing command	0 is code for servo IC

Examples of system control are as follows :

Register name \ Operation	① DUMMY	② S/S	③ BCON	④ BRAK	⑤ ATT	⑥ MUTE	⑦ S/S timer reset	⑧ IC code
MUTE						0		0
ATT					1	1		1
0.3sec.KICK → CLV		1					0	1
0.3sec.BRAKE → MOTOR OFF		0	0				0	1
BRAKE		0	1	1			0	1
MOTOR OFF		0	1	0			0	1
0.3sec. timer disable							1	1
MOTOR off (without 0.3sec. BRAKE)		0	0				1	1
CLV (without 0.3sec. KICK)		1	0				1	1
The following is example of the most simplified system control sequence.								
STOP		0	0	0	0	0	1	1
0.3sec. KICK → CLV		1	0	0	0	0	0	1
PLAY		1	0	0	0	1	0	1
FF/FR		1	0	0	1	1	0	1
PLAY		1	0	0	0	1	0	1
0.3sec. BRAKE → STOP		0	0	0	0	0	0	1

* The blanks mean "Don't care" or that other commands can be used simultaneously.

When the M50427FP detects whether the number of rotations is 2/3 that of the normal play state and outputs the disk rotation deterioration signal to the DRD pin.

The rotation of the disk can be correctly stopped by means of the following stop sequence.

Register name \ Operation or μ -COM Operation	① DUMMY	② S/S	③ BCON	④ BRAK	⑤ ATT	⑥ MUTE	⑦ S/S timer reset	⑧ IC code
PLAY		1	0	0	0	1	0	1
BRAKE		0	1	1	0	0	0	1
(HFD : H checking by microcomputer)								
(Measuring tDRD (DRD : 0 → 1) after BRAKE start								
(Stop HFD checking and) additional BRAKE time 2 × tDRD								
MOTOR OFF		0	1	0	0	0	0	1

To re-initiative the microcomputer interface register, after power supply on, execute $\overline{ACL\overline{R}}$ (M50427FP clear).

4. Digital filter

The sampling frequency of the data is converted from 44.1 kHz to 88.2kHz by the digital filter.

The filter is a 27-tap FIR phase linear filter and includes an overflow limiter.

The digital filter can be by-passed by means of the DFPAS pin. At this time, all the D-A interface timing signals are changed according to the sampling frequency (44.1kHz).

Fig. 4 shows the characteristics of the digital filter.

5. Interface to the D-A converter

The interface to the D-A converter is via the MSB first or LSB first serial data and timing signals. Interface mode selection is done by the DASEL₁ and DASEL₂. The data and the timing signals are as follows :

MODE	DASEL 2	DASEL 1	DO	DSCK	WDCK	LRCK	DWCK
0	0	0	MSB 1st	DATA SHIFT CLOCK	Word clock	L/R clock	-
1	0	1	LSB 1st	DATA SHIFT CLOCK	Lch sampling clock	Rch sampling clock	-
2	1	0	MSB1st Without interpolation	DATA SHIFT CLOCK	Word clock	L/R clock	-
3	1	1	MSB 1st	DATA SHIFT CLOCK	Lch sampling clock	Rch sampling clock	Word clock

Fig. 5 (a) shows the timing diagram of mode0 and mode2 (without interpolation).

Fig. 5 (b) shows the timing diagram of mode1.

Fig. 5 (c) shows the timing diagram of mode2.

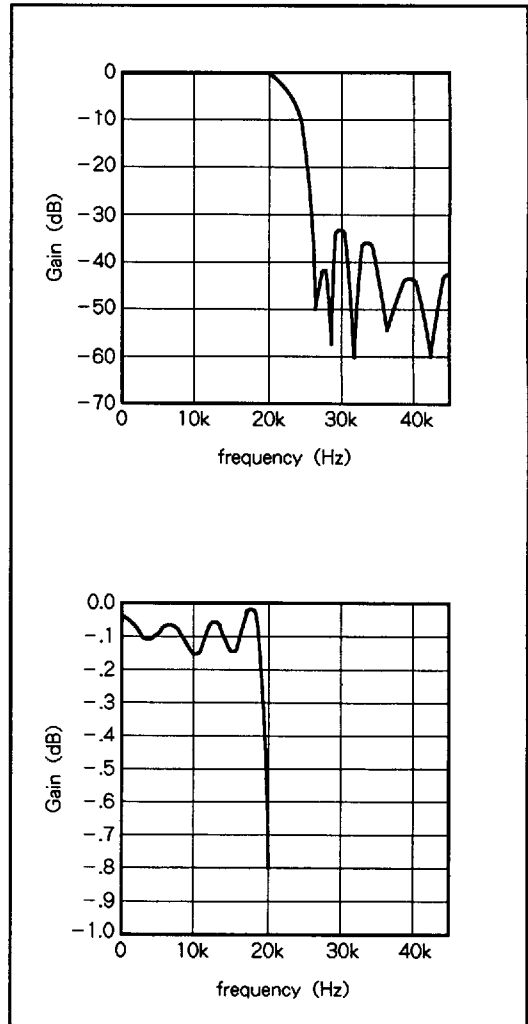

Fig. 4 Frequency characteristics of the digital filter

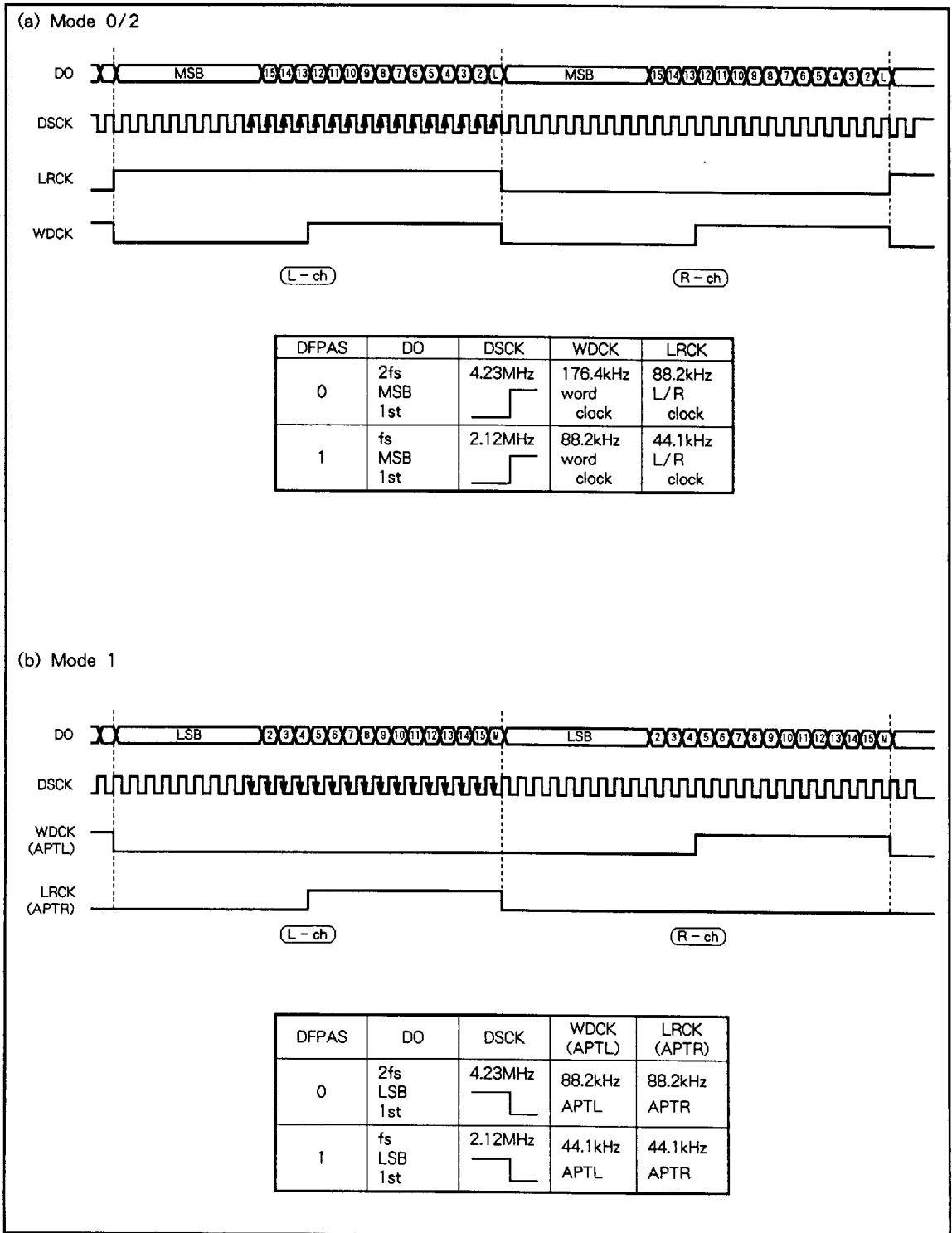

Fig. 5 DAC Interface timing

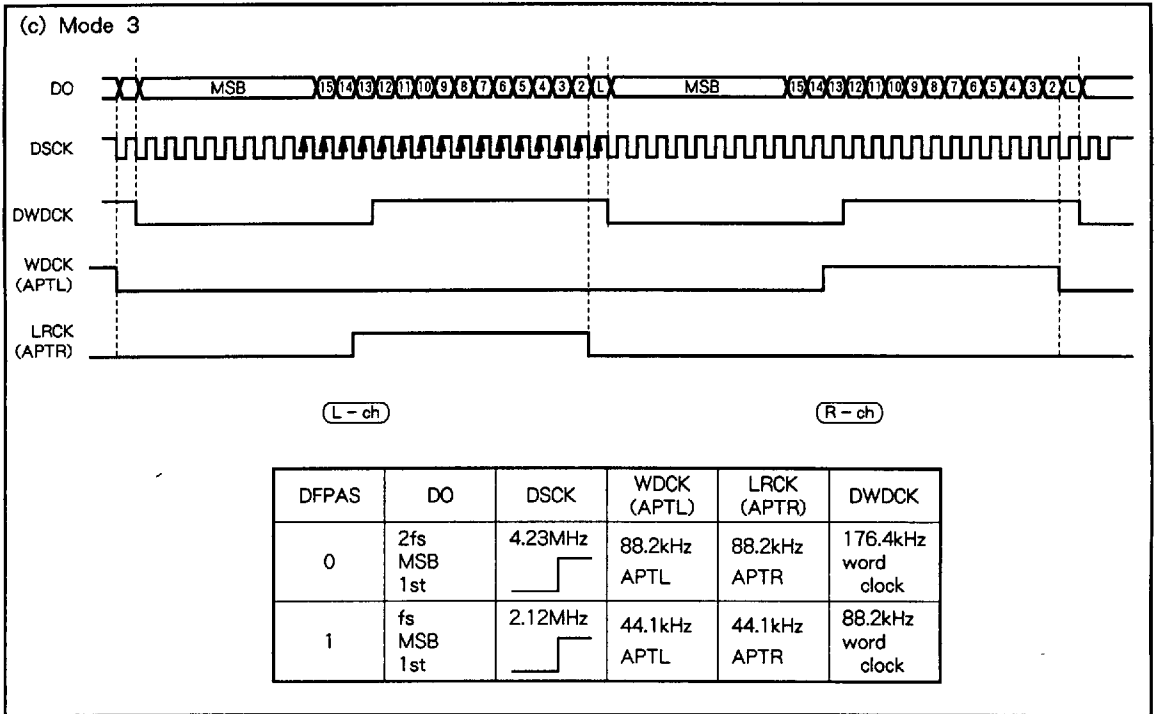

Fig. 5 DAC interface timing

6. CLV servo control

CLV servo control circuit operates using two signals. The first is the frequency difference of EFM clock and X'tal clock. The second is the phase difference of write frame address and read frame address of external, 64K/256K RAM. The M50427FP has CLV servo control circuit internal phase compensated.

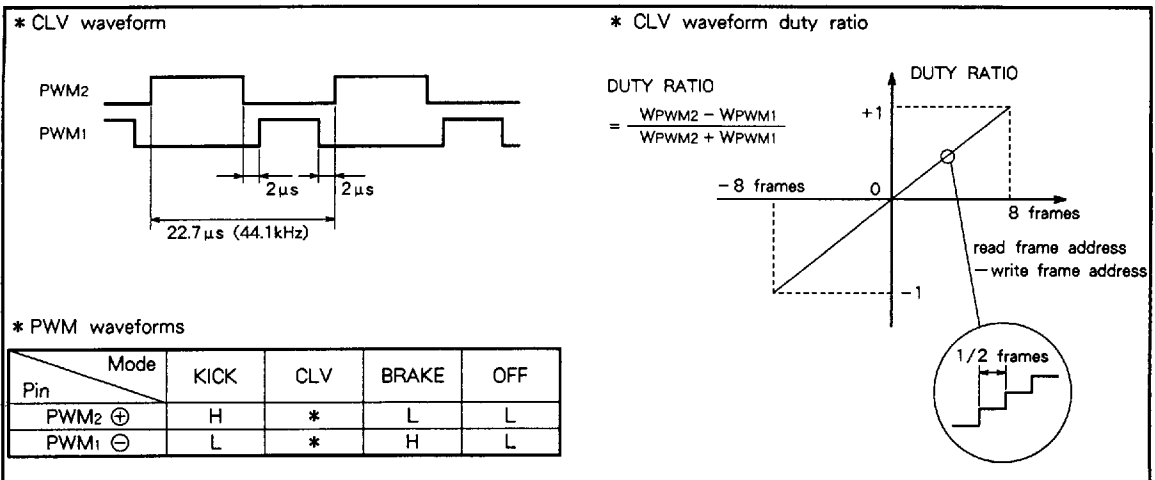

Fig. 6 CLV waveform