

M51137FP

ELECTRONIC VOLUME CONTROL WITH TONE CONTROLLER FOR MULTIAMPLIFIER APPLICATIONS

DESCRIPTION

The M51137FP is a Bi-CMOS IC developed for audio-visual systems. It is suitable for multiamplifiers, being used for processing small analog signals in the stage before power amplifier. The IC uses 8-bit serial data transmitted from a microcomputer in order to perform sound control such as master volume control (VCA system), tone control (bass, mid, and treble), and bass boosting. Its applications also include use as a single output and car audio systems.

FEATURES

- Built-in VCA circuit for main volume control
- Variable volume range..... - 96dB~ + 9dB
- Capability of controlling VCA from external source
- Built-in bass booster enhances heavy bass
- Tone control
 - Treble..... - 10dB~ + 16dB (2dB/step)
 - Mid..... - 10dB~ + 10dB (2dB/step)
 - Bass..... - 10dB~ + 16dB (2dB/step)
 - Bass boost..... - 10dB~ + 10dB (2dB/step)
- For controlling in each mode, the IC uses built-in microcomputer interface and serial data that regulates volume (8-bit), treble, mid, bass, and bass boost (4-bit)

www.DataSheet4U.com

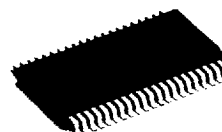

Outline 42P2R-A

0.8mm pitch 450mil SSOP
(8.4mm × 17.5mm × 2.0mm)

RECOMMENDED OPERATING CONDITIONS

- Supply voltage range..... $V_{CC} = 7.5 \sim 12V$
- Rated supply voltage..... $V_{CC} = 9V$

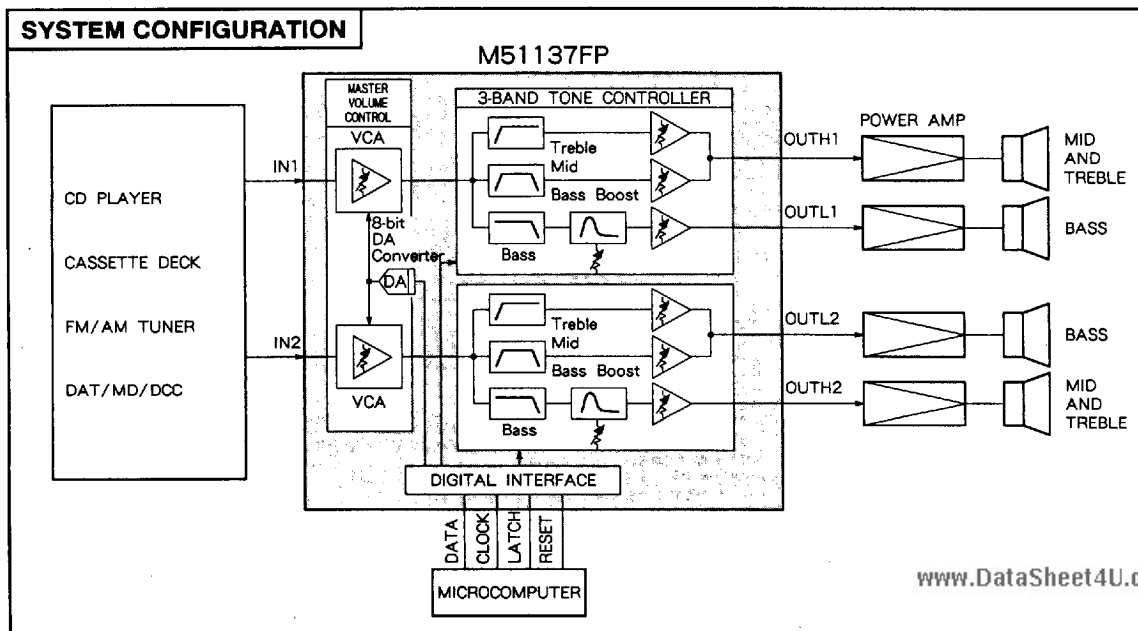

M51137FP

ELECTRONIC VOLUME CONTROL WITH TONE CONTROLLER FOR MULTIAMPLIFIER APPLICATIONS

PIN CONFIGURATION

VCA IN1	1	42	VCA IN2
VCA OUT1	2	41	VCA OUT2
BPF IN1	3	40	BPF IN2
HPF IN1	4	39	HPF IN2
LPF IN1	5	38	LPF IN2
FILTER REF1 OUT1	6	37	FILTER REF2 OUT2
ANALOG GND1	7	38	ANALOG GND2
BASS BOOST1	8	35	BASS BOOST2
BASS BOOST OUT1	9	34	BASS BOOST OUT2
BASS BOOST IN1	10	33	BASS BOOST IN2
TONE HIGH OUT1	11	32	TONE HIGH OUT2
BUFFER HIGH IN1	12	31	BUFFER HIGH IN2
BUFFER HIGH OUT1	13	30	BUFFER HIGH OUT2
TONE LOW OUT1	14	29	TONE LOW OUT2
BUFFER LOW IN1	15	28	BUFFER LOW IN2
BUFFER LOW OUT1	16	27	BUFFER LOW OUT2
RESET	17	26	VCA CONTROL
LATCH	18	26	D/A OUT
CLOCK	19	24	FILTER
DATA	20	23	Vcc
LOGIC GND	21	22	REFERENCE OUT

Outline 42P2R-A

www.DataSheet4U.com

IC INTERNAL BLOCK DIAGRAM

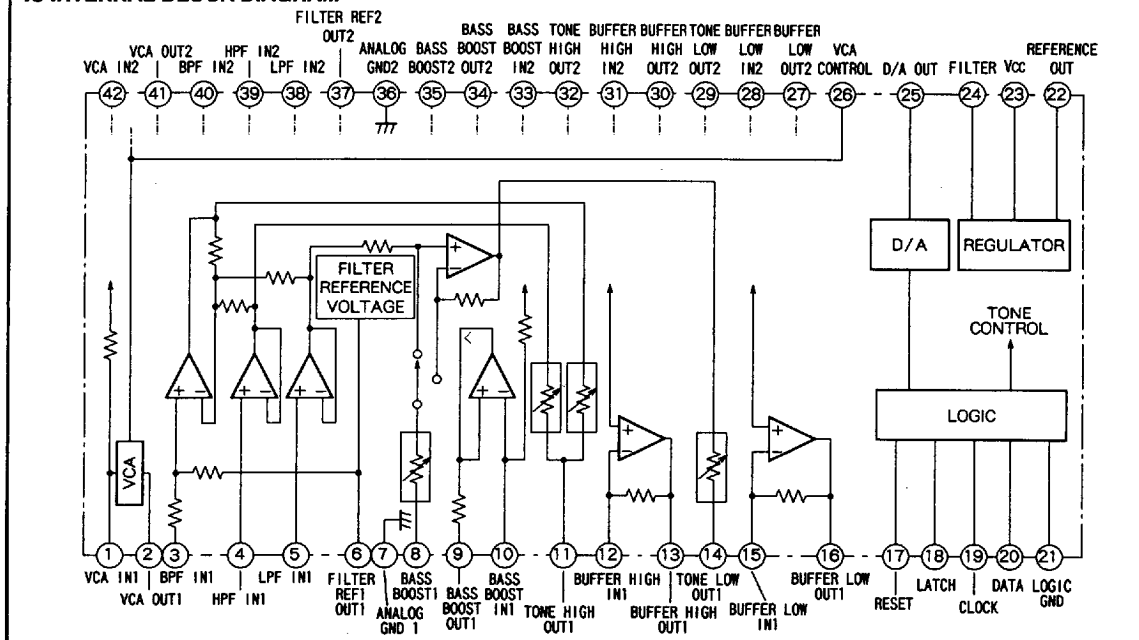

ELECTRONIC VOLUME CONTROL WITH TONE CONTROLLER FOR MULTIAMPLIFIER APPLICATIONS

PIN DESCRIPTION

Pin No.	Name	Function
① (②)	VCA IN 1 (2)	Signal input terminal of ch1 (2)
② (④)	VCA OUT 1 (2)	Signal output terminal of ch1 (2)
③ (④)	BPF IN 1 (2)	BPF input terminal of ch1 (2)
④ (⑤)	HPF IN 1 (2)	HPF input terminal of ch1 (2)
⑤ (⑥)	LPF IN 1 (2)	LPF input terminal of ch1 (2)
⑥ (⑦)	Filter REF 1 (2)	Filter output for analog reference voltage
⑦ (⑧)	Analog GND 1 (2)	Ground of analog circuit
⑧ (⑨)	Bass-boost 1 (2)	Bass-boost gain terminal
⑨ (⑩)	Bass-boost OUT 1 (2)	Bass-boost resonance Amplifier output
⑩ (⑪)	Bass-boost IN 1 (2)	Bass-boost resonance Amplifier input
⑪ (⑫)	Tone high OUT 1 (2)	Treble, mid output
⑫ (⑬)	Buffer high IN 1 (2)	Treble, mid buffer input
⑬ (⑭)	Buffer high OUT 1 (2)	Treble, mid buffer output
⑭ (⑮)	Tone low OUT 1 (2)	Bass, bass-boost out
⑮ (⑯)	Buffer low IN 1 (2)	Bass, bass-boost buffer input
⑯ (⑰)	Buffer low OUT 1 (2)	Bass, bass-boost buffer output
⑰	RESET	MUTE. Set Volume minimum and tone control minimum by high level voltage.
⑱	LATCH	Latch signal of serial data from microcomputer to the IC. Operate at rising edges of pulse.
⑲	CLOCK	Clock signal of serial data from microcomputer to the IC. Operate at rising edges of pulse.
⑳	DATA	Serial data input. (LSB first)
㉑	Logic GND	Ground of digital circuit
㉒	REFERENCE OUT	Reference output voltage source. (5.8Vtyp)
㉓	Vcc	Supply voltage (7.5~12V)
㉔	FILTER	Filter for ripple
㉕	D/A OUT	VCA control voltage source by D/A convertor
㉖	VCA CONTROL	VCA gain control terminal

ABSOLUTE MAXIMUM RATINGS

Symbol	Parameter	Ratings	Unit
V _{cc}	Supply voltage	14	V
V _I	Digital input voltage	-0.3~7.0	V
P _d	Power dissipation	1000 * standard board	mW
K _θ	Thermal derating	10 (T _a ≥ 25°C)	mW/°C
T _{opr}	Operating temperature	-10~+70	°C
T _{stg}	Storage temperature	-40~+125	°C

* Standard board

- board size 70mm × 70mm
- board thickness 1.6mm
- board material glass epoxy
- copper pattern
 - copper thickness 18μm
 - copper size 0.25mm(width) 30mm(length/lead)

ELECTRONIC VOLUME CONTROL WITH TONE CONTROLLER FOR MULTIAMPLIFIER APPLICATIONS

ELECTRICAL CHARACTERISTICS

(Ta = 25°C, Vcc = 9V, Control data : FF5550 (volume max/ tone flat), f = 1kHz, unless otherwise noted)

Symbol	Parameter	Test conditions							Measurement point	Limits			Unit
		Input condition	Control data	Switch condition				Min		Typ	Max		
				SA	SB1	SB2	SC						
Icc	Circuit current	Quiescent	FF5550	OPEN	OPEN	BPF	a	PIN⑳	26	38	50	mA	
VREF	Reference voltage	↑	↑	↑	↑	↑	↑	PIN㉑	5.4	5.8	6.3	V	
VFIL	Filter voltage	↑	↑	↑	↑	↑	↑	PIN㉒	8.2	8.9	-	V	
I _{IH}	Level "H" input current	V _{IH} = 4.5V	FF5550	OPEN	OPEN	BPF	b	PIN㉓ PIN㉔ PIN㉕	0.3	1.0	3.0	μA	
I _{IL}	Level "L" input current	V _{IL} = 0.5V	↑	↑	↑	↑	↑	↑	-0.3	0.0	0.3	μA	
OFSTM1	Tre/mid switching offset voltage	Quiescent (data switching offset voltage difference)	FF050 ↳ FF0A50	OPEN	OPEN	BPF	a	PIN㉖ PIN㉗	-20	0	+20	mV	
OFSBB1	Boost switching offset voltage 1	↑	FF5550 ↳ FF5555	↑	↑	↑	↑	PIN㉘ PIN㉙	-10	0	+10	mV	
OFSBB2	Boost switching offset voltage 2	↑	FF5550 ↳ FF555D	↑	↑	↑	↑	PIN㉚ PIN㉛	-10	0	+10	mV	
CBVT	Total channel balance 1	(Calculation)	-	-	-	-	-	CB + CBT	-3	0	3	dB	
CBVM	Total channel balance 2	(Calculation)	-	-	-	-	-	CB + CBM	-3	0	3	dB	
CBVB	Total channel balance 3	(Calculation)	-	-	-	-	-	CB + CBBA	-3	0	3	dB	
ATT (min)	Minimum Attenuation level	V _i = -14dBV *1	FF5550	CLOSE	OPEN	BPF	a	A(1), A(2)	7.2	9.0	10.8	dB	
CB	Channel balance	↑	↑	↑	↑	↑	↑	A(1)/A(2)	-1.8	0	1.8	dB	
THD	Total harmonic distortion	V _i = -14dBV, *1 BPF = 400Hz ~ 30kHz	↑	↑	↑	↑	↑	A(1), A(2)	-	0.02	0.1	%	
No (min)	Noise voltage	Quiescent IHF-A	↑	OPEN	↑	↑	↑	↑	-	25.0	56.0	μVrms	
THD (max)	Maximum total harmonic distortion	V _i = -3dBV, *1 BPF = 400Hz ~ 30kHz	↑	CLOSE	↑	↑	↑	↑	-	0.1	1.0	%	
ATT (-10)	Attenuation level (-10dB)	V _i = -14dBV *1	9A5550	↑	↑	↑	↑	↑	-2.8	-1.0	0.8	dB	
ATT (max)	Maximum attenuation level	V _i = -3dBV, *1 IHF-A	005550	↑	↑	↑	↑	↑	-	-97	-77	dB	
No	Maximum attenuation noise voltage	Quiescent IHF-A	↑	OPEN	↑	↑	↑	↑	-	10.0	20.0	μVrms	
CT	Cross talk	V _i = -3dBV, *1 IHF-A	FF5550	OPEN/ CLOSE CLOSE/ OPEN	↑	↑	↑	↑	-	-90	-70	dB	
GVT	Voltage gain	V _i = -5dBV *2	FF5550	OPEN	CLOSE	HPF	a	B(1), B(2)	-19	-17	-15	dB	
CBT	Channel balance	↑	↑	↑	↑	↑	↑	B(1)/B(2)	-2	0	+2	dB	
THDT	Total harmonic distortion	V _i = -5dBV BPF = 400Hz ~ 30kHz	↑	↑	↑	↑	↑	B(1), B(2)	-	0.01	0.1	%	
NoT	Noise voltage	Quiescent IHF-A	↑	↑	OPEN	↑	↑	↑	-	4.0	8.0	μVrms	

ELECTRONIC VOLUME CONTROL WITH TONE CONTROLLER FOR MULTIAMPLIFIER APPLICATIONS

ELECTRICAL CHARACTERISTICS (cont.)

(Ta = 25°C, Vcc = 9V, Control data : FF5550 (volume max/ tone flat), f = 1kHz, unless otherwise noted)

Symbol	Parameter	Test conditions						Measurement point	Limits			Unit	
		Input condition	Control data	Switch condition					Min	Typ	Max		
				SA	SB1	SB2	SC						
TREBLE	THDT max	Maximum total harmonic distortion	Vi=+6dBV, *2 BPF=400Hz~30kHz	FFD550	OPEN	CLOSE	HPF	a	B(1), B(2)	-	0.1	1.0	%
	GVT (max)	Maximum voltage gain	Vi = - 5dBV *2	↑	↑	↑	↑	↑	↑	-3	-1	+1	dB
	GVT (min)	Minimum voltage gain	↑	FF0550	↑	↑	↑	↑	↑	-29	-27	-25	dB
CTT	Cross talk	Vi = + 6dBV *2 IHF-A	FFD550	↑	OPEN/ CLOSE CLOSE/ OPEN	↑	↑	↑	-	-80	-60	dB	
GVM	Voltage gain	Vi = - 5dBV *3	FF5550	OPEN	CLOSE	BPF	a	B(1), B(2)	-19	-17	-15	dB	
CBM	Channel balance	↑	↑	↑	↑	↑	↑	B(1)/ B(2)	-2	0	+2	dB	
THDM	Total harmonic distortion	Vi = - 5dBV BPF=400Hz~30kHz	↑	↑	↑	↑	↑	B(1), B(2)	-	0.01 ^A	0.1	%	
NoM	Noise voltage	Quiescent IHF-A	↑	↑	OPEN	↑	↑	↑	-	4.0	8.0	μVrms	
MID	THDM max	Maximum total harmonic distortion	Vi=+6dBV, *3 BPF=400Hz~30kHz	FF5A50	↑	CLOSE	↑	↑	↑	-	0.1	1.0	%
	GVM (max)	Maximum voltage gain	Vi = - 5dBV *3	↑	↑	↑	↑	↑	↑	-9	-7	-5	dB
	GVM (min)	Minimum voltage gain	↑	FF5050	↑	↑	↑	↑	↑	-29	-27	-25	dB
CTM	Cross talk	Vi = + 6dBV, *3 IHF-A	FF5A50	↑	OPEN/ CLOSE CLOSE/ OPEN	↑	↑	↑	-	-80	-60	dB	
GVBA	Voltage gain	Vi = - 5dBV *4	FF5550	OPEN	CLOSE	LPF	a	C(1), C(2)	-19	-17	-15	dB	
CBBA	Channel balance	↑	↑	↑	↑	↑	↑	C(1)/ C(2)	-2	0	+2	dB	
THDBA	Total harmonic distortion	Vi = - 5dBV BPF=400Hz~30kHz	↑	↑	↑	↑	↑	C(1), C(2)	-	0.01	0.1	%	
NoBA	Noise voltage	Quiescent IHF-A	↑	↑	OPEN	↑	↑	↑	-	4.0	8.0	μVrms	
THDBA max	Maximum total harmonic distortion	Vi=+6dBV, *4 BPF=400Hz~30kHz	FF55D0	↑	CLOSE	↑	↑	↑	-	0.1	1.0	%	
BASS	GVBA (max)	Maximum voltage gain	Vi = - 5dBV *4	↑	↑	↑	↑	↑	↑	-3	-1	+1	dB
	GVBA (min)	Minimum voltage gain	↑	FF5500	↑	↑	↑	↑	↑	-29	-27	-25	dB
	CTBA	Cross talk	Vi = + 6dBV *4 IHF-A	FF55D0	↑	OPEN/ CLOSE CLOSE/ OPEN	↑	↑	↑	-	-80	-60	dB
THDBB max	Boost maximum total harmonic distortion	Vi=-10dBV, *4 BPF=400Hz~30kHz	FF55D5	↑	CLOSE	↑	↑	↑	-	0.1	1.0	dB	
GVBB (max)	Boost maximum voltage gain	Vi = - 10dBV *4 f = 800Hz	FF5555	↑	↑	↑	↑	↑	10	-7	-5	dB	
GVBB (min)	Boost minimum voltage gain	↑	FF555D	↑	↑	↑	↑	↑	-29	-27	-24	dB	

Note : *1 ; Vi is VCA input voltage. *2 ; Vi is HPF input voltage. *3 ; Vi is BPF input voltage. *4 ; Vi is LPF input voltage.

ELECTRONIC VOLUME CONTROL WITH TONE CONTROLLER FOR MULTIAMPLIFIER APPLICATIONS

TEST CIRCUIT

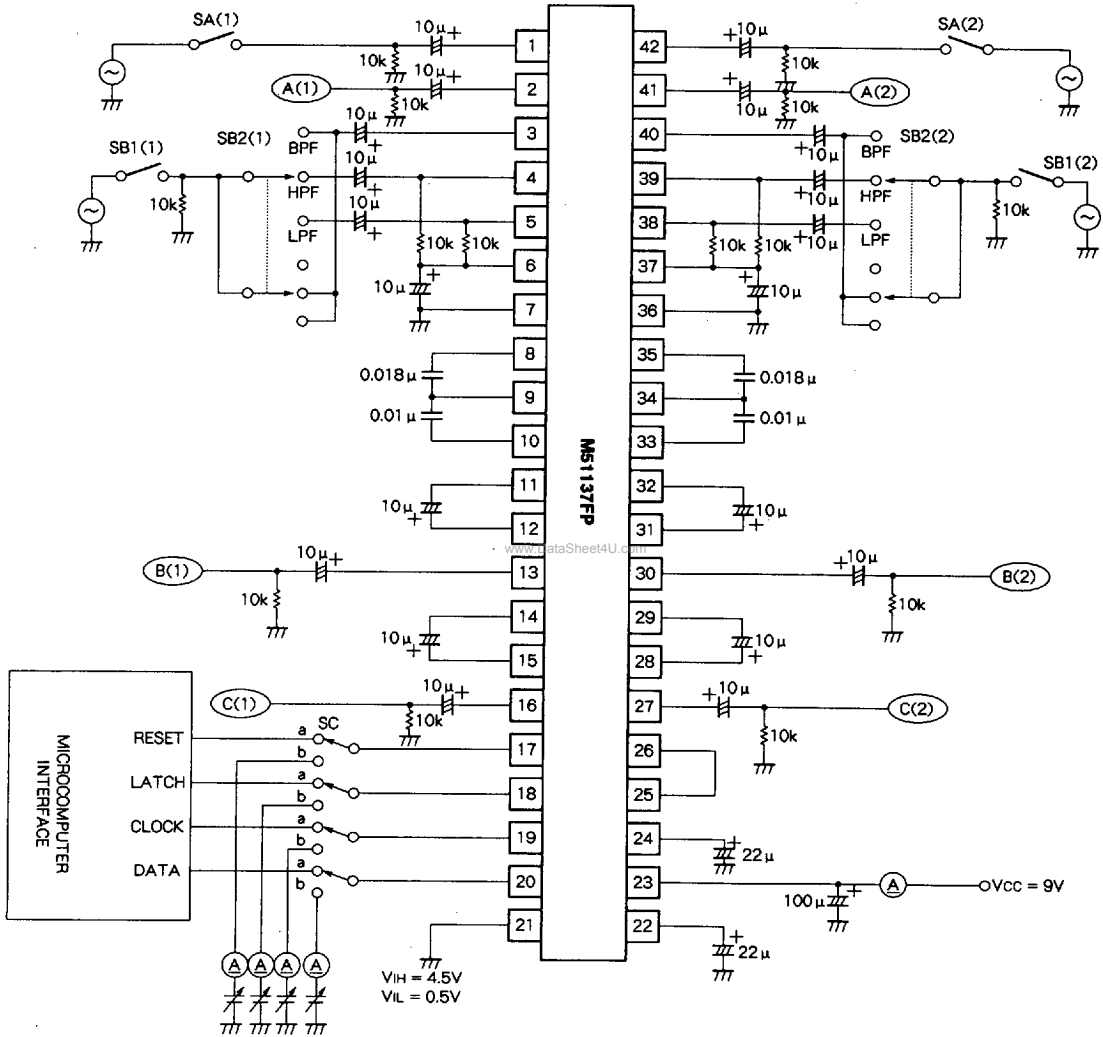

ELECTRONIC VOLUME CONTROL WITH TONE CONTROLLER FOR MULTIAMPLIFIER APPLICATIONS

OPERATIONAL DESCRIPTION

1. CONTROL METHOD

(1) DIGITAL CONTROL SPECIFICATION

Data format

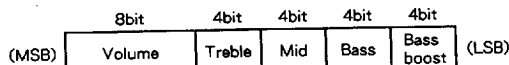

- Volume : 00~FF (8bit D/A data)
- Treble : 0~D (14 step)
- Mid : 0~A (11 step)
- Bass : 0~D (14 step)
- Bass-boost : 0 (11 step)
- 1~5
- 9~D

TIMING DIAGRAM (RECOMMENDED CONDITION)

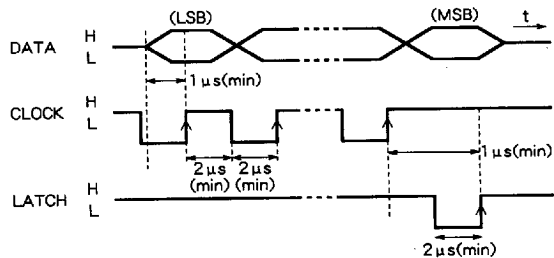

- Note 1. RESET (MUTE) is volume minimum and tone control minimum by "H" level.
Puls width 2µs(min)
- 2. CLOCK, LATCH functions operates at rising edge of pulse.
- 3. Recommended input level
"H" level : more than 4V
"L" level : less than 1V
the, threshold voltage (Logic input buffer) is about 2.5V.

CONTROL DATA TABLE

D/A converter for VCA		TREBLE		MID		BASS		BASS-BOOST	
DATA	OUTPUT VOLTAGE	DATA	GAIN	DATA	GAIN	DATA	GAIN	DATA	GAIN
00	Vz	0	- 10dB	0	- 10dB	0	- 10dB	0	± 0dB
01	$\frac{255Vz + Vf}{256}$	1	- 8dB	1	- 8dB	1	- 8dB	1	+ 2dB
		2	- 6dB	2	- 6dB	2	- 6dB	2	+ 4dB
		3	- 4dB	3	- 4dB	3	- 4dB	3	+ 6dB
		4	- 2dB	4	- 2dB	4	- 2dB	4	+ 8dB
		5	± 0dB	5	± 0dB	5	± 0dB	5	+ 10dB
		6	+ 2dB	6	+ 2dB	6	+ 2dB	6	-
		7	+ 4dB	7	+ 4dB	7	+ 4dB	7	-
		8	+ 6dB	8	+ 6dB	8	+ 6dB	8	-
		9	+ 8dB	9	+ 8dB	9	+ 8dB	9	- 2dB
		A	+ 10dB	A	+ 10dB	A	+ 10dB	A	- 4dB
		B	+ 12dB	B	-	B	+ 12dB	B	- 6dB
		C	+ 14dB	C	-	C	+ 14dB	C	- 8dB
		D	+ 16dB	D	-	D	+ 16dB	D	- 10dB
		FE	$\frac{2Vz + 254Vf}{256}$	E	-	E	-	E	-
FF	$\frac{Vz + 255Vf}{256}$	F	-	F	-	F	-	F	-

Note typical or designed value. Vz, Vf is internal power supply voltage.
+ 12dB~+ 16dB of treble and bass are for loudness.

ELECTRONIC VOLUME CONTROL WITH TONE CONTROLLER FOR MULTIAMPLIFIER APPLICATIONS

VCA GAIN LEVEL (EXAMPLE)

Control data (D/A converter)	VCA gain level (dB)
0F	(Maximum attenuation)
1F	- 79
2F	- 59
3F	- 44
4F	- 32
5F	- 23
6F	- 15
7F	- 9
8F	- 4
9F	0
AF	+ 3
BF	+ 5
CF	+ 6
DF	+ 7
EF	+ 8
FF	+ 9

(2) SIGNAL PROCESSING SYSTEM

{System} {Total gain : - 8dB (VCA MAX)}

www.DataSheet4U.com

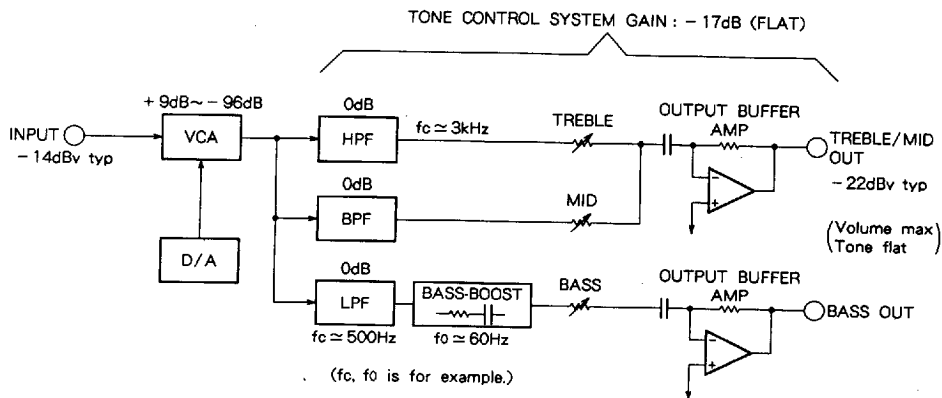

Voltage gain (designed value. Tone control system gain : - 17dB (flat))

- Volume : + 9dB ~ - 96dB typ. (VCA)
- Treble : - 10dB ~ 0dB ~ + 10dB (2dB/step)
(+ 12dB, + 14dB, + 16dB for loudness)
- Mid : - 10dB ~ 0dB ~ + 10dB (2dB/step)
- Bass : - 10dB ~ 0dB ~ + 10dB (2dB/step)
(+ 12dB, + 14dB, + 16dB for loudness)
- Bass-boost : - 10dB ~ 0dB ~ + 10dB (2dB/step)

ELECTRONIC VOLUME CONTROL WITH TONE CONTROLLER FOR MULTIAMPLIFIER APPLICATIONS

TYPICAL CHARACTERISTICS

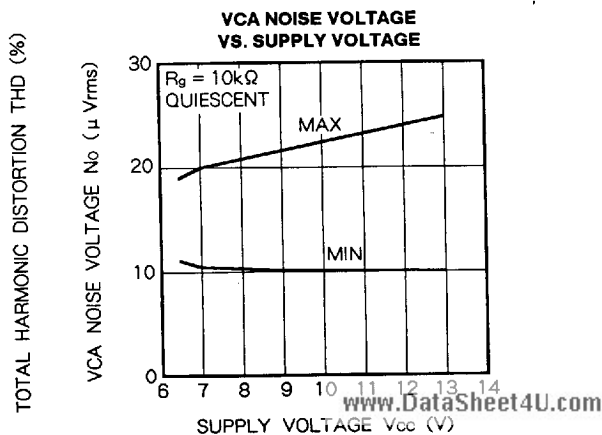
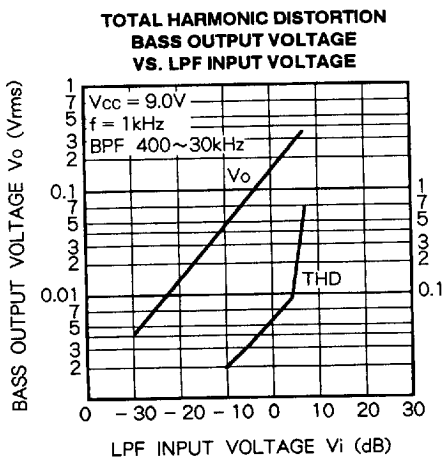
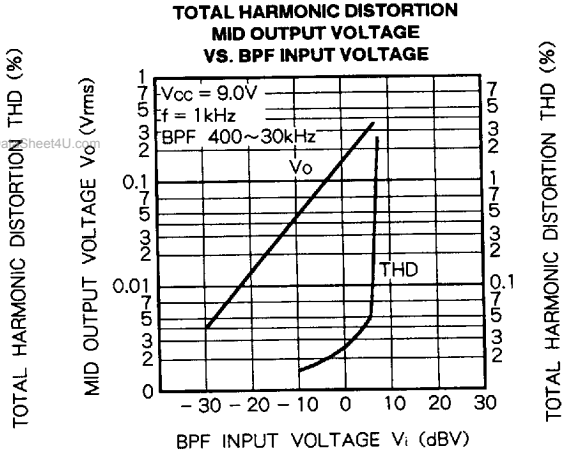
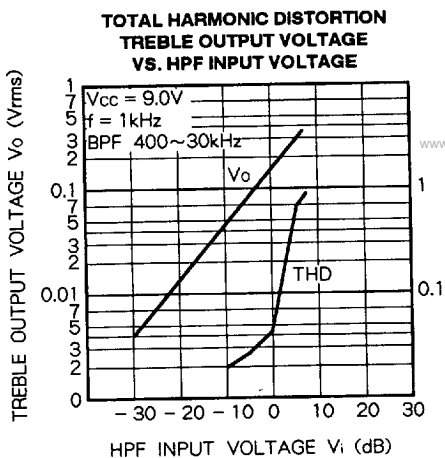
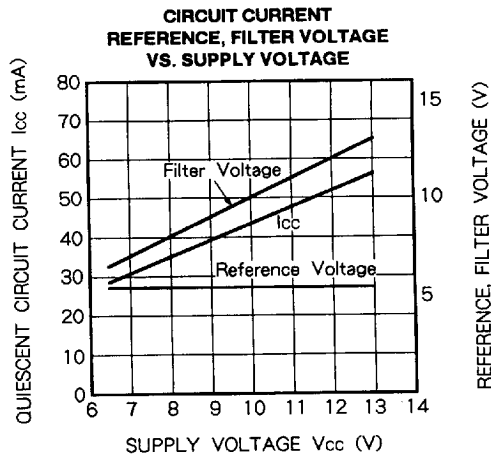
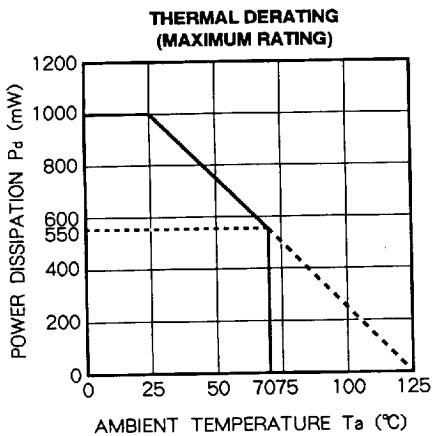

ELECTRONIC VOLUME CONTROL WITH TONE CONTROLLER FOR MULTIAMPLIFIER APPLICATIONS

**TOTAL HARMONIC DISTORTION
VCA OUTPUT VOLTAGE
VS. VCA INPUT VOLTAGE**

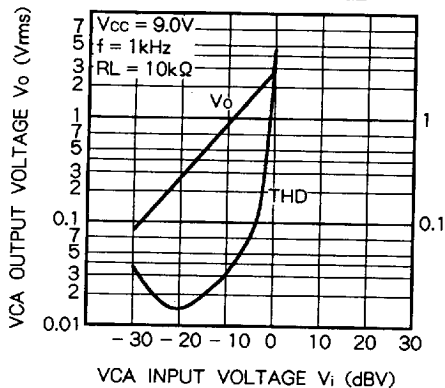

**ATTENUATION LEVEL
VS. DA OUT VOLTAGE**

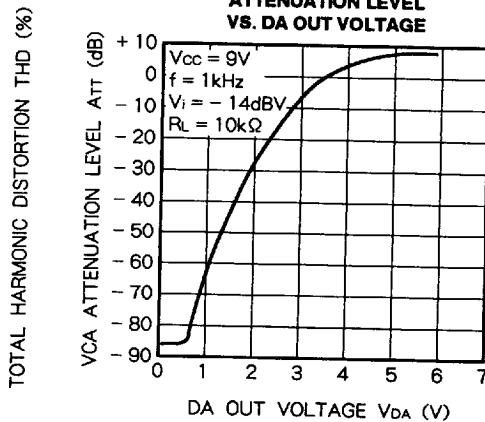

**TONE NOISE VOLTAGE
VS. SUPPLY VOLTAGE**

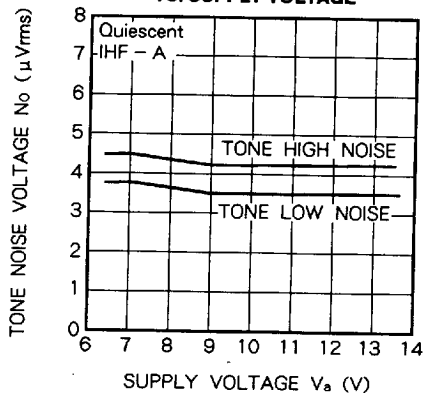

**TREBLE VOLTAGE GAIN
VS. TEMPERATURE**

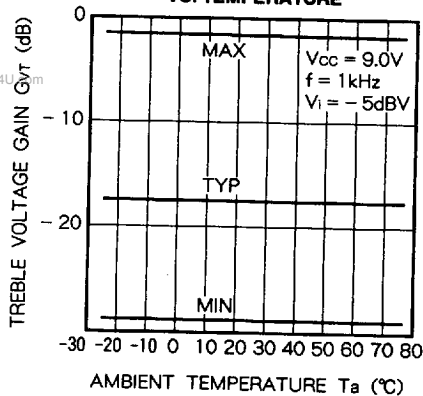

**MID VOLTAGE GAIN
VS. TEMPERATURE**

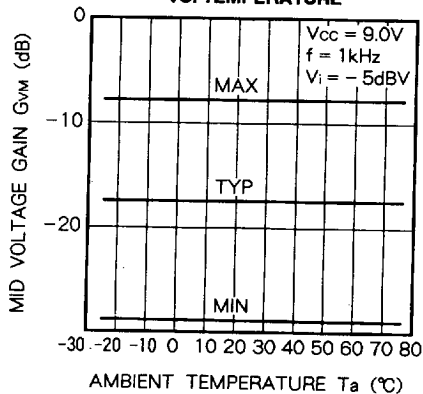

**BASS VOLTAGE GAIN
VS. TEMPERATURE**

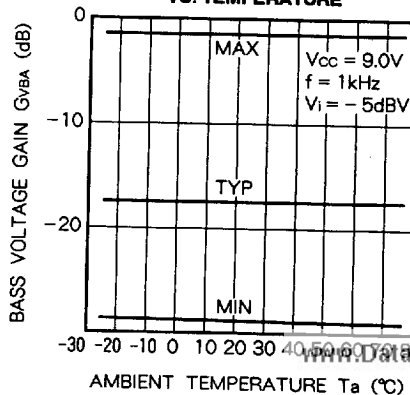

www.DataSheet4U.com

www.DataSheet4U.com

M51137FP

ELECTRONIC VOLUME CONTROL WITH TONE CONTROLLER FOR MULTIAMPLIFIER APPLICATIONS

APPLICATION NOTES

- (1) Take care of the heat radiation of PCB.
- (2) Take care of a PCB design about digital noise.
- (3) The IC has three GND pins.
- (4) Take care of electrostatic damage of ⑥ pin and ⑩ pin.
- (5) Take care of gain characteristics of tone control. The loose attenuation characteristics of filters will disturb the frequency reponse in another filtering region.

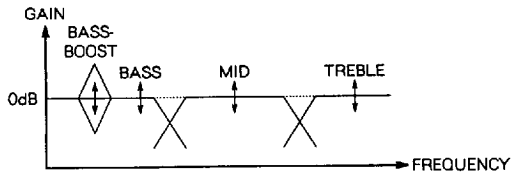

(6) NOISE IMPROVEMENT METHOD

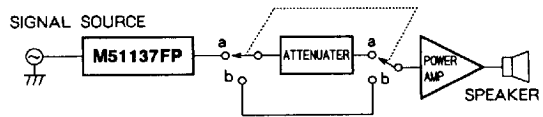

The additional attenuator improves the noise characteristics for small signals.

Volume : Small.....a
Volume : Large.....b

APPLICATION EXAMPLE 1 (Bi-amplifier system)

www.DataSheet4U.com

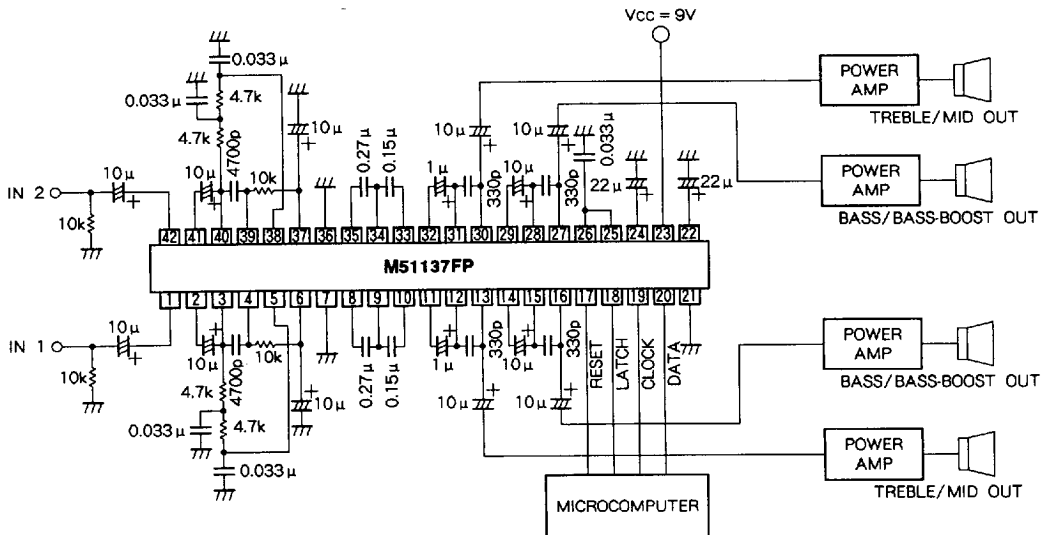

Units Resistance : Ω
Capacitance : F

M51137FP

ELECTRONIC VOLUME CONTROL WITH TONE CONTROLLER FOR MULTIAMPLIFIER APPLICATIONS

APPLICATION EXAMPLE 2 (Three dimensional type)

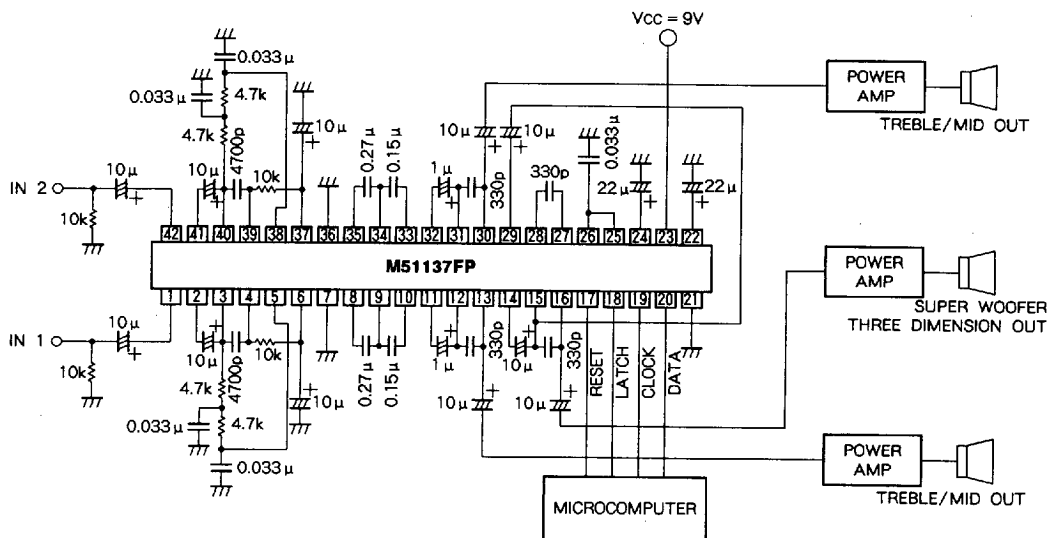

www.DataSheet4U.com

Units Resistance : Ω
Capacitance : F

APPLICATION EXAMPLE 3 (Standard type)

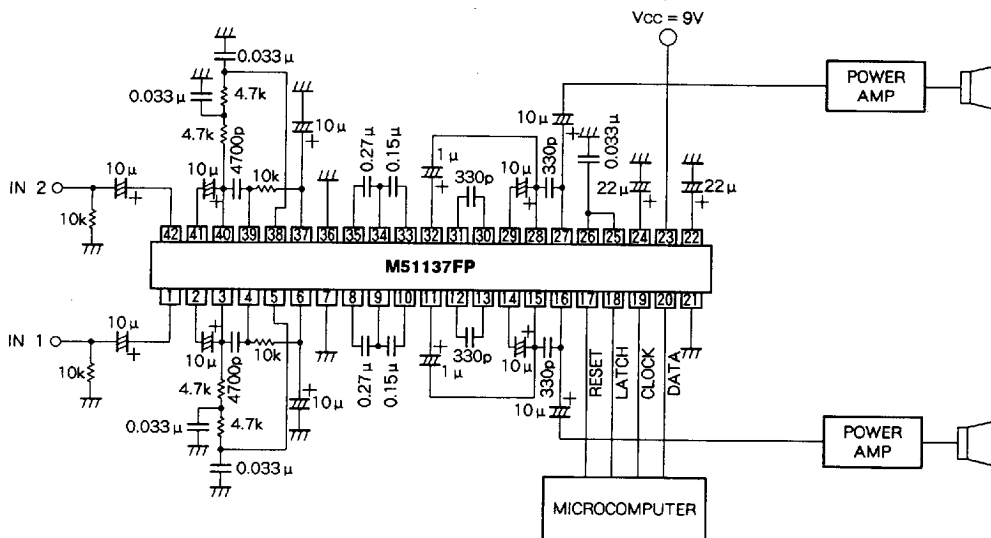

Units Resistance : Ω
www.DataSheet4U.com