

M51162P

RECORDING/PLAYBACK PREAMPLIFIER FOR STEREO CASSETTE TAPE RECORDER

DESCRIPTION

The M51162P is a recording and playback preamplifier for stereo cassette tape recorders. The IC built-in recording/playback mode selector switches and 2 channels of preamplifiers with an ALC circuit. This configuration realizes compact designs and a system with good channel balance.

FEATURES

- Built-in microphone and equalizer amplifiers with electronic switches.
- Built-in line amplifiers with ALC.
- Low noise $1\mu\text{Vrms}$ ($R_0 = 1\text{k}\Omega$)
- Low distortion ratio 0.2% ($V_o = 1\text{Vrms}$)

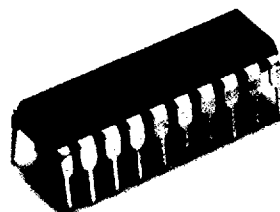

Outline 20P4

2.54mm pitch 300mil DIP
(6.3mm × 24.0mm × 3.3mm)

RECOMMENDED OPERATING CONDITIONS

Supply voltage range $V_{cc} = 3.5\sim 12\text{V}$
 Rated supply voltage $V_{cc} = 9\text{V}$

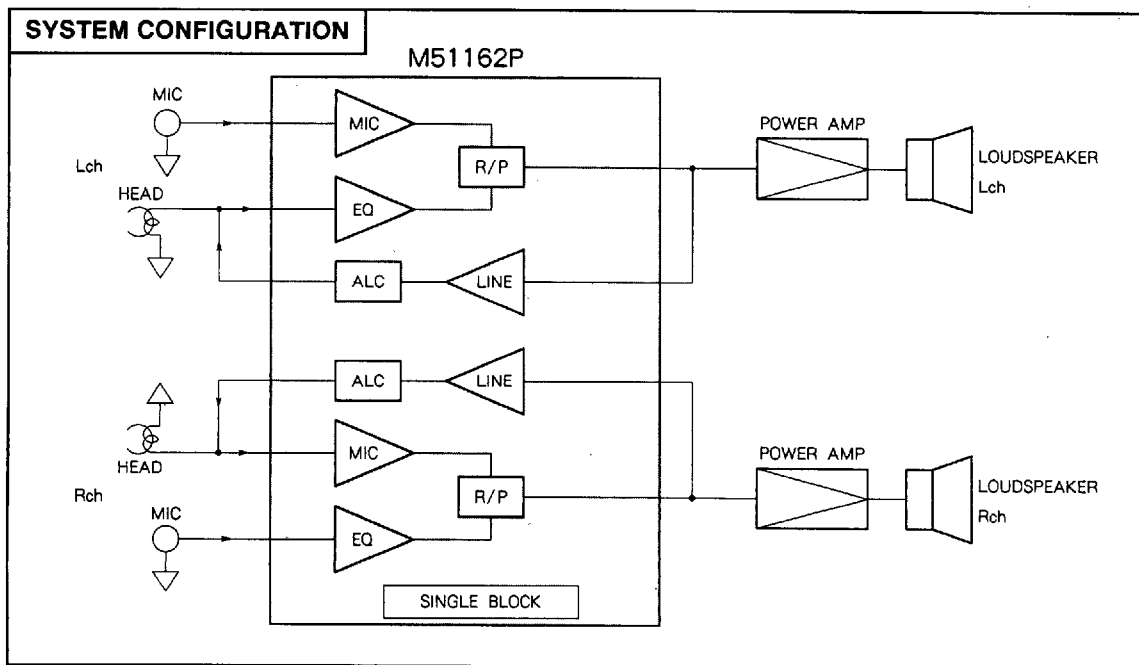

M51162P

RECORDING/PLAYBACK PREAMPLIFIER FOR STEREO CASSETTE TAPE RECORDER

PIN CONFIGURATION

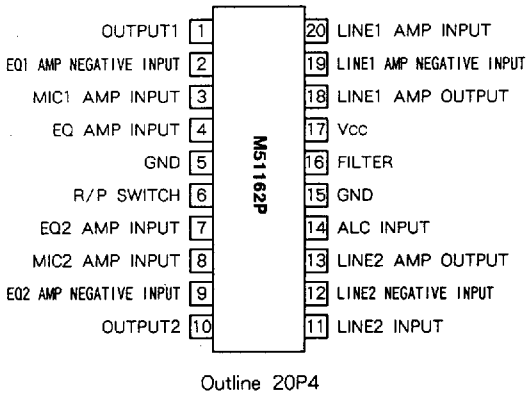

IC INTERNAL BLOCK DIAGRAM

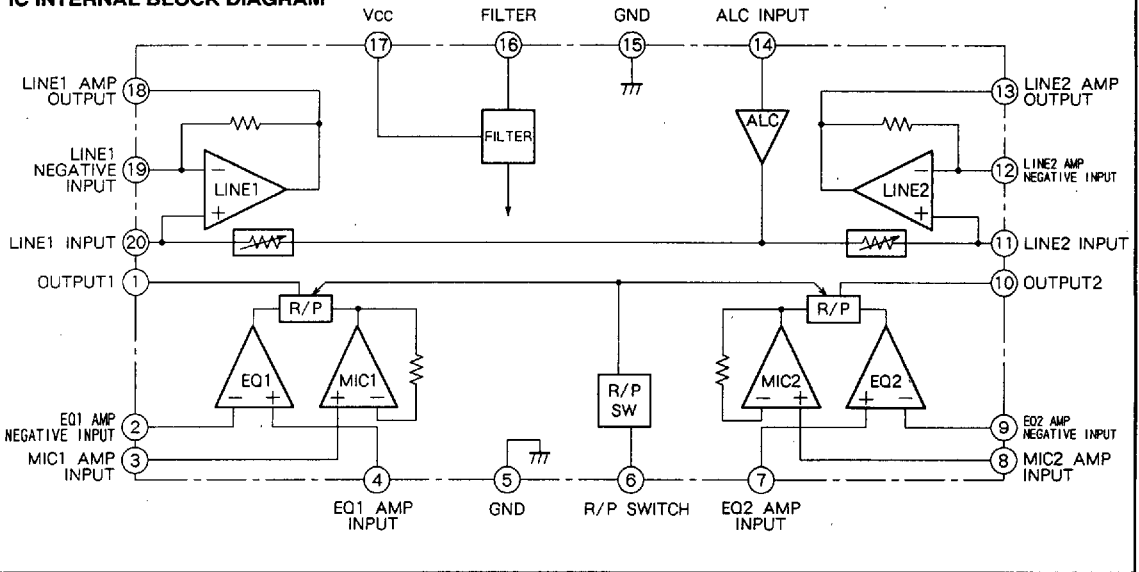

M51162P

RECORDING/PLAYBACK PREAMPLIFIER FOR STEREO CASSETTE TAPE RECORDER

ABSOLUTE MAXIMUM RATINGS (Ta = 25 °C, unless otherwise noted)

Symbol	Parameter	Ratings	Unit
Vcc	Supply voltage	18	V
Icc	Circuit current	100	mA
Pa	Power dissipation	1000	mW
Kθ	Thermal derating (Ta ≥ 25 °C)	10	mW/°C
Topt	Operating temperature	-20~+75	°C
Tstg	Storage temperature	-40~+125	°C

ELECTRICAL CHARACTERISTICS (Ta = 25 °C, Vcc = 9V, f = 1kHz, unless otherwise noted)

Symbol	Parameter	Test conditions	Limits			Unit
			Min	Typ	Max	
Icco	Quiescent circuit current	Playback mode	5	10	15	mA
GVM1	MIC amplifier CH-1	Voltage gain	Vom = 1Vrms			dB
VOM1		Maximum output voltage	THD = 3%			
THDM1		Total harmonic distortion	Vom = 1Vrms			
ZiM1		Input impedance	Mi voltage when input = 10mVrms			
NiM1		Equivalent input noise voltage	Rg = 1kΩ, 30~20kHz BPF			
GVP1	EC amplifier CH-1	Voltage gain	Vop = 1Vrms			dB
VOP1		Maximum output voltage	THD = 3%			
THDP1		Total harmonic distortion	Vop = 1Vrms			
ZiP1		Input impedance	Pi voltage when input = 10mVrms			
NiP1		Equivalent input noise voltage	Rg = 1kΩ, 30~20kHz BPF			
GVL1	Line-recording amplifier CH-1	Voltage gain	Vol = 1Vrms			dB
VOL1		Maximum output voltage	THD = 3%			
THDL1		Total harmonic distortion	Vol = 1Vrms			
ZiL1		Input impedance	Li voltage when input = 10mVrms			
NiL1		Equivalent input noise voltage	Rg = 1kΩ, 30~20kHz BPF			
ALCA	ALC circuit	ALC range	From the point ALC is activated until output is 3dB up.			dB
ALCTHD		ALC distortion	Input distortion, from the point ALC is activated until input reaches +20dB.			
ALCb		ALC balance	The difference in CH-1/CH-2 ALC output level, from the point ALC is activated until input reaches +20dB.			

Note. Electrical characteristics for channel 2 are the same as channel 1.

M51162P

RECORDING/PLAYBACK PREAMPLIFIER FOR STEREO CASSETTE TAPE RECORDER

TEST CIRCUIT

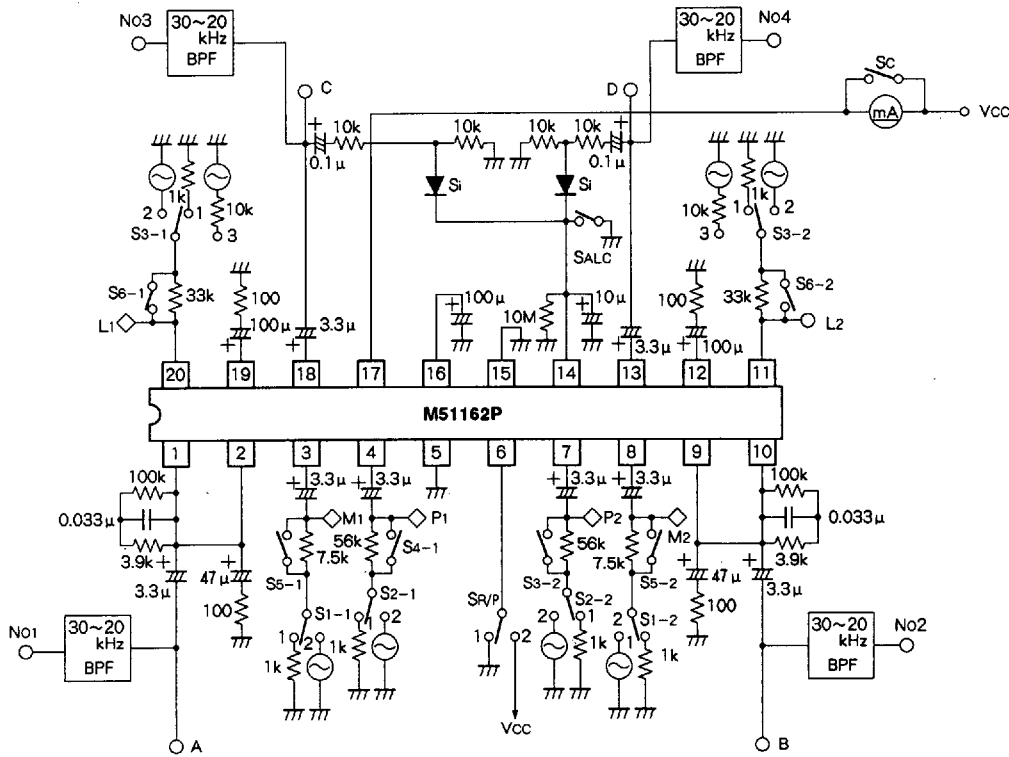

Units Resistance : Ω
Capacitance : F

TEST METHODS

	Parameter	Switch conditions										Test point									
		Symbols	SR/P	Sc	S1-1,2	S2-1,2	S3-1,2	S4-1,2	S5-1,2	S6-1,2	SALC	A	B	C	D	P1,2	M1,2	L1,2	mA	No1,2	No3,4
MIC amplifier	I _{CCO}	1	OFF	1	1	1	ON	ON	ON	OFF											
	G _{VM1,2}	2	ON	2	1	1	ON	ON	ON	OFF	\bigcirc	\bigcirc									
	V _{OM1,2}	\uparrow	\uparrow	\uparrow	\uparrow	\uparrow	\uparrow	\uparrow	\uparrow	\uparrow	\bigcirc	\bigcirc									
	THD _{M1,2}	\uparrow	\uparrow	\uparrow	\uparrow	\uparrow	\uparrow	\uparrow	\uparrow	\uparrow	\bigcirc	\bigcirc									
	Z _{IM1,2}	\uparrow	\uparrow	\uparrow	\uparrow	\uparrow	\uparrow	OFF	\uparrow	\uparrow						\bigcirc					
EQ amplifier	N _{IM1,2}	1	\uparrow	\uparrow	\uparrow	\uparrow	ON	ON	ON										\bigcirc		
	G _{VP1,2}	1	ON	1	2	1	ON	ON	ON	OFF	\bigcirc	\bigcirc									
	V _{OP1,2}	\uparrow	\uparrow	\uparrow	\uparrow	\uparrow	\uparrow	\uparrow	\uparrow	\uparrow	\bigcirc	\bigcirc									
	THD _{P1,2}	\uparrow	\uparrow	\uparrow	\uparrow	\uparrow	\uparrow	\uparrow	\uparrow	\uparrow	\bigcirc	\bigcirc									
	Z _{IP1,2}	\uparrow	\uparrow	\uparrow	\uparrow	\uparrow	\uparrow	OFF	\uparrow	\uparrow					\bigcirc						
Line-recording amplifier	N _{IP1,2}	\uparrow	\uparrow	\uparrow	\uparrow	\uparrow	ON	\uparrow	\uparrow	\uparrow										\bigcirc	
	G _{VL1,2}	2	ON	2	1	2	ON	ON	ON	OFF				\bigcirc	\bigcirc						
	V _{OL1,2}	\uparrow	\uparrow	\uparrow	\uparrow	\uparrow	\uparrow	\uparrow	\uparrow	\uparrow				\bigcirc	\bigcirc						
	THD _{L1,2}	\uparrow	\uparrow	\uparrow	\uparrow	\uparrow	\uparrow	\uparrow	\uparrow	\uparrow				\bigcirc	\bigcirc						
	Z _{IL1,2}	\uparrow	\uparrow	\uparrow	\uparrow	\uparrow	\uparrow	OFF	\uparrow	\uparrow							\bigcirc				
A/C circuit	N _{IL1,2}	\uparrow	\uparrow	\uparrow	\uparrow	\uparrow	\uparrow	ON	\uparrow	\uparrow											\bigcirc
	ALCA	2	ON	2	1	3	ON	ON	ON	ON				\bigcirc	\bigcirc						
	ALCTHD	\uparrow	\uparrow	\uparrow	\uparrow	\uparrow	\uparrow	\uparrow	\uparrow	\uparrow				\bigcirc	\bigcirc						
	ALCB	\uparrow	\uparrow	\uparrow	\uparrow	\uparrow	\uparrow	\uparrow	\uparrow	\uparrow				\bigcirc	\bigcirc						

M51162P

RECORDING/PLAYBACK PREAMPLIFIER FOR STEREO CASSETTE TAPE RECORDER

TYPICAL CHARACTERISTICS

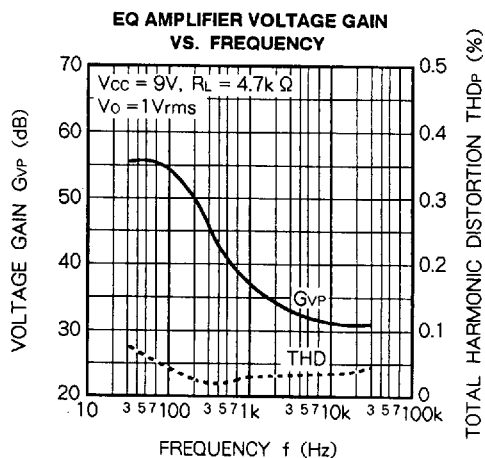
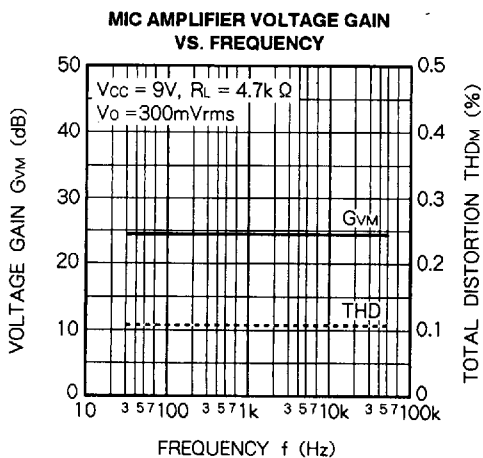
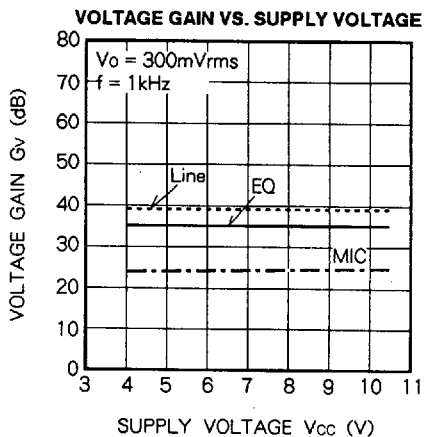
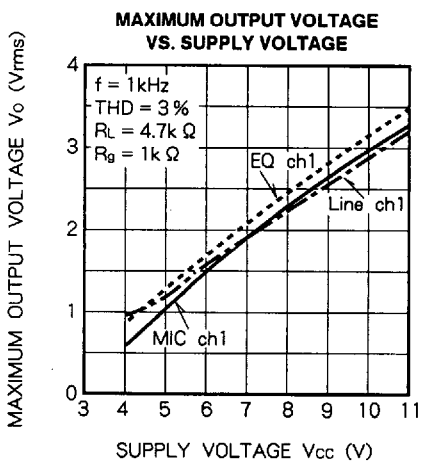
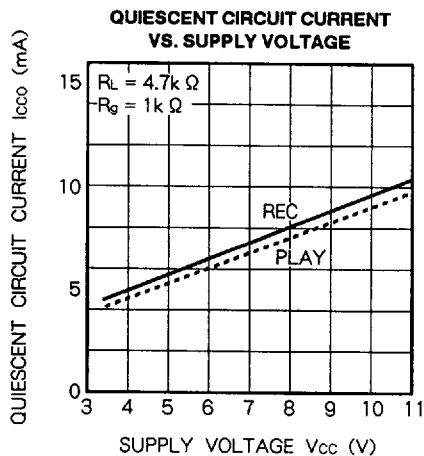
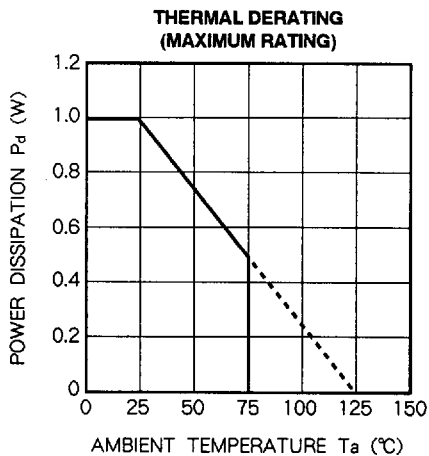

M51162P

RECORDING/PLAYBACK PREAMPLIFIER FOR STEREO CASSETTE TAPE RECORDER

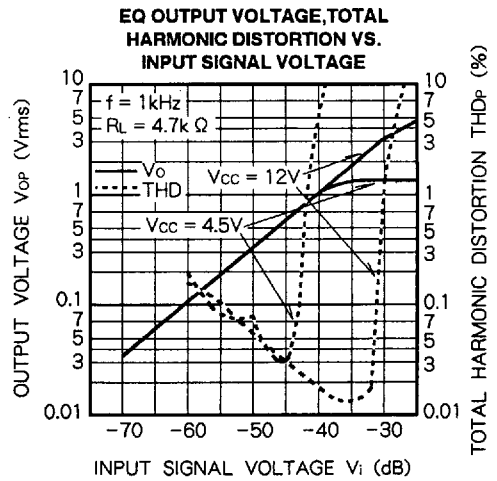
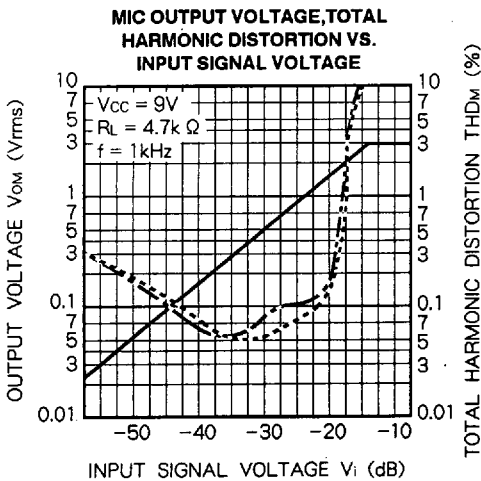
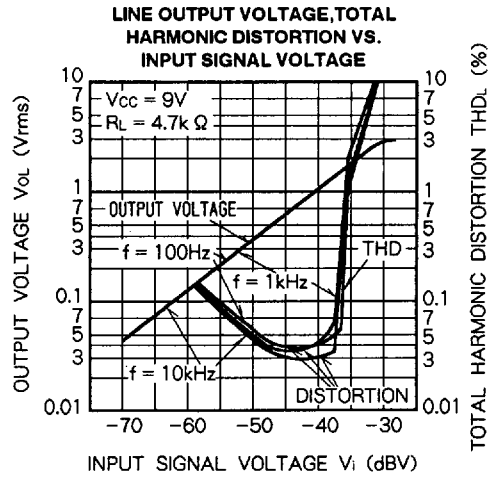
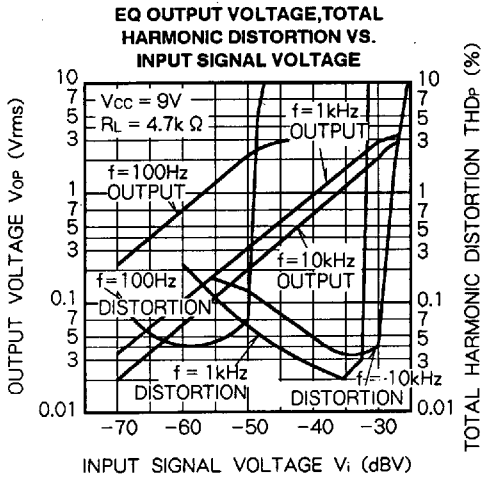
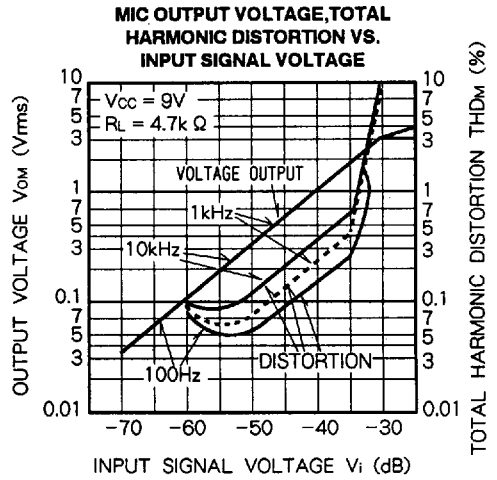
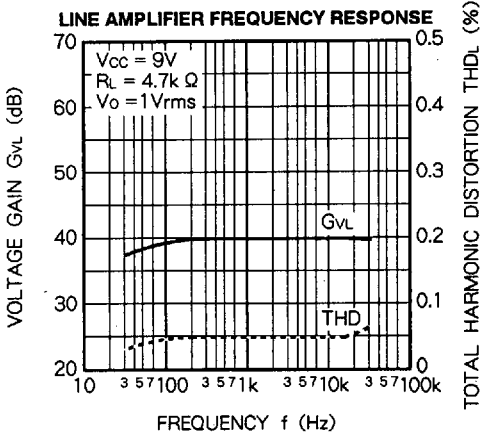

M51162P

RECORDING/PLAYBACK PREAMPLIFIER FOR STEREO CASSETTE TAPE RECORDER

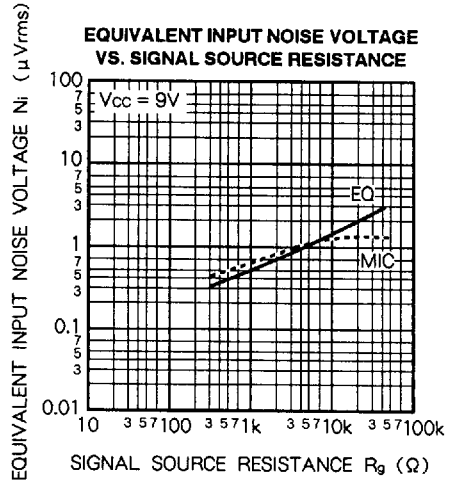
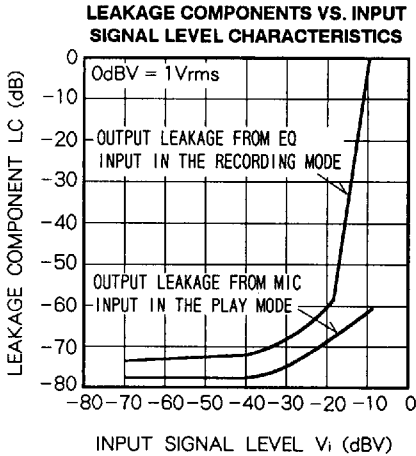

FUNCTION AND TERMINAL DESCRIPTION

1. EQ amplifier

Normally connected to the input from the magnetic head, this amplifier functions to set equalization for proper playback of the tape being used.

●EQ amp input pins, pin ④ and pin ⑦. Input impedance, 56kΩ typ.

Negative feedback pins, pin ② and pin ⑨.

Output pins, pin ① and pin ⑩. (EQ/MIC output is switched by electronic switch.)

2. MIC amplifier

Functions to amplify the input signal from the microphone connection. The circuitry of this amplifier is the same as the EQ amp, and gain is fixed at 24dB.

●MIC amp input pins, pin ③ and pin ⑧. Input impedance 7.5kΩ typ.

Output pins, pin ① and pin ⑩.

3. Line amplifier

Functions to further amplify the signal received from the EQ, MIC and other amplifiers. Can also be used as the recording amplifier.

●Line amp input pins, pin ⑪ and pin ⑭. Input impedance 33kΩ typ.

Negative feedback pins, pin ⑫ and pin ⑬

Output pins, pin ⑬ and pin ⑮

4. ALC circuit

Functions to automatically control the level of the input signal by using a built-in variable resistor.

●ALC circuit input pin, pin ⑭

Variable resistor pins, pin ⑪ and pin ⑯

In the playback mode, ALC operations are automatically disabled.

5. R/P switch

Switching between the recording and playback mode is accomplished through a DC voltage signal.

●R/P switch control pin, pin ⑥

Recording mode: Control voltage, more than 2.2V, more than 100µA current.

Playback mode: Grounded

6. Filter

pin ⑮

7. Power supply

pin ⑰

8. Ground

pin ⑤ and ⑱