

MITSUBISHI ELEK (LINEAR)

# M51289FP/M51299FP

PAL VIDEO CHROMA SIGNAL PROCESSOR

## DESCRIPTION

The M51289FP/M51299FP are video signal processing integrated circuits developed for a PAL system color LCD TV.

These ICs have a built-in luminance signal processing circuit and color signal processing circuit, which convert a composite video signal to an RGB signal.

## FEATURES

- Low voltage, low power dissipation design
- The number of peripheral parts used is reduced by a builtin Y/C separation circuit.
- Sync separation circuit built in these ICs
- Provided with Y-signal blanking function by HD pulse
- R.G.B signal output
- Tint, contrast, picture quality (PIX) and color controls linearly adjustable
- 24-pin shrink flat package adopted
- Same package as in NTSC system video chroma IC M51286FP, pins perfectly compatible with each other
- M51289FP: C-signal blanked by HD pulse
- M51299FP: No C-signal blanked by HD pulse

## PIN CONFIGURATION (TOP VIEW)

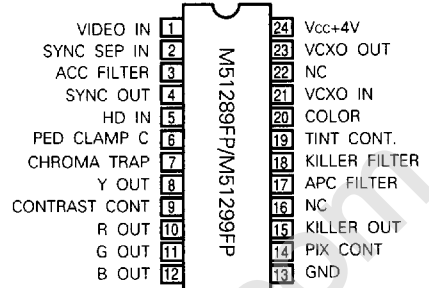

Outline 24P2Q-A

NC: No connection

## APPLICATIONS

LCD color TV and LCD color view finder

## RECOMMENDED OPERATING CONDITIONS

Supply voltage range .....3.5V~4.5V  
 Rated supply voltage .....4.0V

## BLOCK DIAGRAM

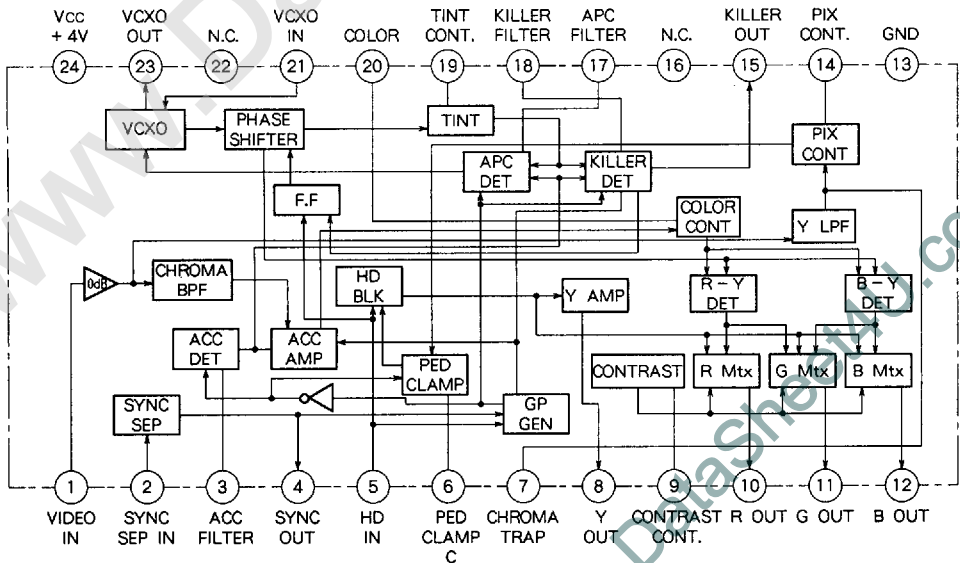

MITSUBISHI ELEK (LINEAR)

M51289FP/M51299FP

PAL VIDEO CHROMA SIGNAL PROCESSOR

## ABSOLUTE MAXIMUM RATINGS

Symbol	Parameter	Ratings	Unit
V <sub>cc</sub>	Supply voltage	4.5	V
P <sub>d</sub>	Power dissipation	540	mW
T <sub>opr</sub>	Operating temperature	-10~70	deg
T <sub>stg</sub>	Storage temperature	-40~120	deg
k <sub>θ</sub>	Thermal derating	5.4	mW/deg
V <sub>max</sub>	Electrostatic capacity	±200 ※	V

※ Charging capacity : 200 pF

ELECTRICAL CHARACTERISTICS (T<sub>a</sub> = 25°C, unless otherwise noted)

Symbol	Parameter	Test No	Test conditions	Limits			Unit
				Min.	Typ.	Max.	
I <sub>cc</sub>	Circuit current	1	Input standard color bar signal of V <sub>cc</sub> =4V	-	14	17	mA
SYNC SEP Section							
V <sub>sync 1</sub> V <sub>sync 7</sub>	SYNC tip voltage	2	Measure each output signal SYNC tip voltage at pins ①, ⑦ when standard color bar signal of 0.7 V <sub>p-p</sub> is input.	2.20 1.25	2.30 1.35	2.40 1.45	V
V <sub>sync H</sub> V <sub>sync L</sub>	SYNC output amplitude	3	Input only SYNC pulse of pulse width 4.7 micro seconds to pin ①. Measure the output amplitude at pin ④ when the input SYNC pulse amplitudes are 0.2 and 0.05 V <sub>p-p</sub> .	2.7 2.7	3.1 3.1	3.3 3.3	V <sub>P-P</sub>
T <sub>sync H</sub> T <sub>sync L</sub>	SYNC output pulse width	4	Input only SYNC pulse of pulse width 4.7 micro seconds to pin ①. Measure the output amplitude at pin ④ when the output SYNC pulse amplitudes are 0.2 and 0.05 V <sub>p-p</sub> .	3.7 3.7	4.7 4.7	5.7 5.7	μsec
D <sub>sync H</sub> D <sub>sync L</sub>	SYNC output pulse delay	5	Input only SYNC pulse of pulse width 4.7 micro seconds to pin ①. Measure the pulse width + delay time when the input SYNC pulse amplitudes are 0.2 and 0.05 V <sub>p-p</sub> .	3.7 3.7	4.7 4.7	6.0 6.0	μsec
Video Section							
VLPF(L) VLPF(H)	YLPF frequency characteristics (Pin ⑦)	6	Measure the frequency at which the sine wave output amplitude is -3 dB when the input signal (  0.2 V <sub>p-p</sub> ) 0.2 V <sub>p-p</sub> is input. Also measure the output gain at input sine wave 3.58 MHz.	1.00 -	1.15 -36	- -25	MHz dB
Y <sub>max</sub>	Maximum output	7	Input standard staircase wave of 0.7 V <sub>p-p</sub> . Measure the output amplitude at pin ⑩ when V <sub>9</sub> is 0 V.	1.2	1.5	1.8	V <sub>P-P</sub>
GY <sub>max</sub>	Video amplifier gain	8	Input standard staircase wave of 0.7 V <sub>p-p</sub> . Calculate the ratio between the output amplitude at pin ⑩ and input amplitude when V <sub>9</sub> is 1.7 V.	4.6	6.5	8.1	dB
Y <sub>ctrast</sub> (1) Y <sub>ctrast</sub> (2.5) Y <sub>ctrast</sub> (3.5)	Contrast control characteristics	9	Input standard staircase wave of 0.7 V <sub>p-p</sub> , and calculate the ratio of the input amplitude to the output amplitude in Test No. 8 above when V <sub>9</sub> is changed 1 V, 2.5V and 3.5V.	0.7 -6.5 -	2.7 -4.5 -22	4.3 -3.0 -20	dB
XPIX(4) XPIX(0)	PIX control characteristics	10	Input 1.5 MHz sine wave of 0.2 V <sub>p-p</sub> to the input. Measure each output amplitude at pin ⑩ when V <sub>9</sub> is 1.7 V, and V <sub>14</sub> is changed to 2, 4 and 0 V and calculate the ratio between the input amplitude and the output amplitude when V <sub>14</sub> = 2 V.	-8.0 3.5	-6.0 6.0	-3.5 9.5	dB
GY <sub>amp</sub>	Y AMP gain	11	Input standard staircase wave of 0.7 V <sub>p-p</sub> and calculate the ratio between the output amplitude at pin ⑩ and input amplitude.	9.1	11.0	12.6	dB
V <sub>ped</sub>	PED offset level	12	Input SYNC pulse 0.2 V <sub>p-p</sub> : Measure the pedestal offset of output at pin ⑩.	10	50	70	mV <sub>P-P</sub>
Chroma Section							
C <sub>max</sub>	Maximum chroma output	13	Increase input burst 0.2 V <sub>p-p</sub> + CW 4.33 MHz CW amplitude, and measure the output amplitude when the output at pin ⑩ starts distortion.	1.8	2.2	2.5	V <sub>P-P</sub>

M51289FP/M51299FP

PAL VIDEO CHROMA SIGNAL PROCESSOR

ELECTRICAL CHARACTERISTICS (cont.)

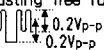
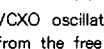
Symbol	Parameter	Test No	Test conditions	Limits			Unit
				Min.	Typ.	Max.	
Cacc (+6)	Acc control characteristics	14	Input burst 0.2 Vp-p + CW 4.33 MHz shall be 0 dB. Measure the output at pin ⑩ when the input is changed to +6 dB and -20 dB, and calculate the ratio of the measured amplitude to the output amplitude at 0 dB.	0	0.7	1.5	dB
Cacc (-20)				-6.0	-2.0	0	
Ckillr	Killer operation	15	Input a chroma signal of 0.2 Vp-p to the input. Reduce the amplitude and measure the amplitude ratio when the voltage at pin ⑩ exceeds 2.5 V.	-52	-48	-44	dB
Cast(3)	Color control characteristics	16	Input burst 0.2 Vp-p + CW 4.33 MHz: change V20 to 1V, 3V, 2V, 0.5V and 0V to measure each output (100kHz beat) amplitude at pin 12, and calculate the ratio between the measured amplitude and the output amplitude at V20 = 1V.	6	8	10	dB
Cast(2)				4	6	8	
Cast(0.5)				-8	-6	-4	
Cast(0)				-	-30	-25	
Δ fapc	APC pull-in range	17	Input only SYNC, and after adjusting free run, input 0.2 Vp-p CW  (0.2Vp-p), then change the frequency.  Measure the frequency when VCXO oscillator is placed in a locked condition from the free-run condition.	+300	+600	-	Hz
				-	-600	-300	
DB	B demodulator sensitivity	18	Input CW 4.33 MHz of 0.2 Vp-p to the input, and measure the output amplitude at pin ⑩ when V20=1 V.	1.4	1.6	1.8	Vp-p
R(R/B)	Demodulated output voltage ratio	19	Input CW 4.33 MHz of 0.2 Vp-p to the input, measure the output amplitude at pins ⑩, ⑪ when V20 = 1 V, and calculate the ratio of the measured amplitude to the output amplitude in Test No. 18 above.	0.65	0.7	0.8	-
R(G/B)				0.35	0.4	0.45	
Dleak R	Demodulated output carrier leak	20	Input CW 4.433619 MHz 0.2 Vp-p: measure the amplitude of 8.8 MHz element of each output at pins ⑩, ⑪, ⑫.	-	35	50	mVp-p
Dleak G				-	35	50	
Dleak B				-	35	50	
Vkiller H	Killer output voltage H	21	Measure DC voltage at pin 15 when 0V and 4V are applied to pin ⑩.	2.5	3.2	-	V
Vkiller L	Killer output voltage L			-	0.15	0.20	
Dhd	HD for chroma delay	22	Apply B monochromatic wave 0.4 Vp-p and burst 0.2 Vp-p to the input. Measure the delay time from HD pulse rise to thr chroma rise of pin ⑩ output.	-	2.0	2.2	μsec
ID	IDENT characteristics	23	The IDENT (identification) characteristics should be not higher than the killer level.	-	-	-	-

MITSUBISHI ELEK (LINEAR) 62E D

**INPUT SIGNAL**

Standard Color Bar: PAL (Standard staircase wave has no chroma signal)

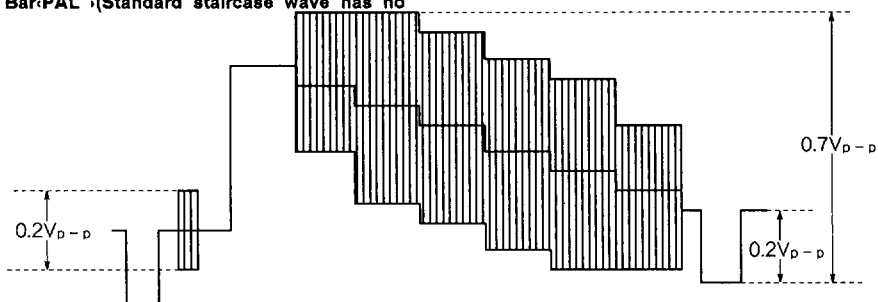

Burst+CW  
(B monochromatic wave, etc.) PAL

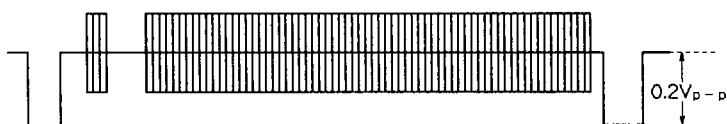

Sine wave

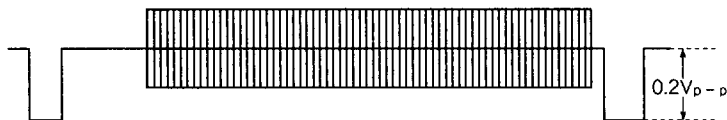

Continuous sine wave  
(CW)

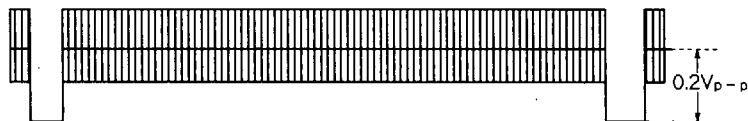

SYNC pulse

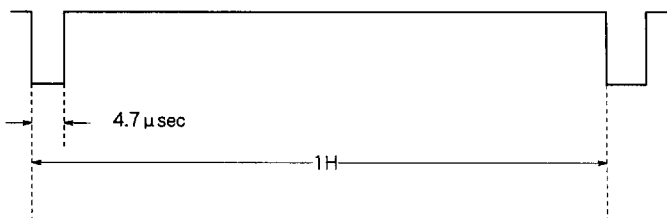

Standard HD signal

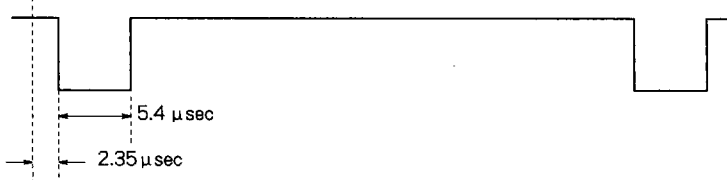

MITSUBISHI ELEK (LINEAR)

M51289FP/M51299FP

PAL VIDEO CHROMA SIGNAL PROCESSOR

TEST CIRCUIT

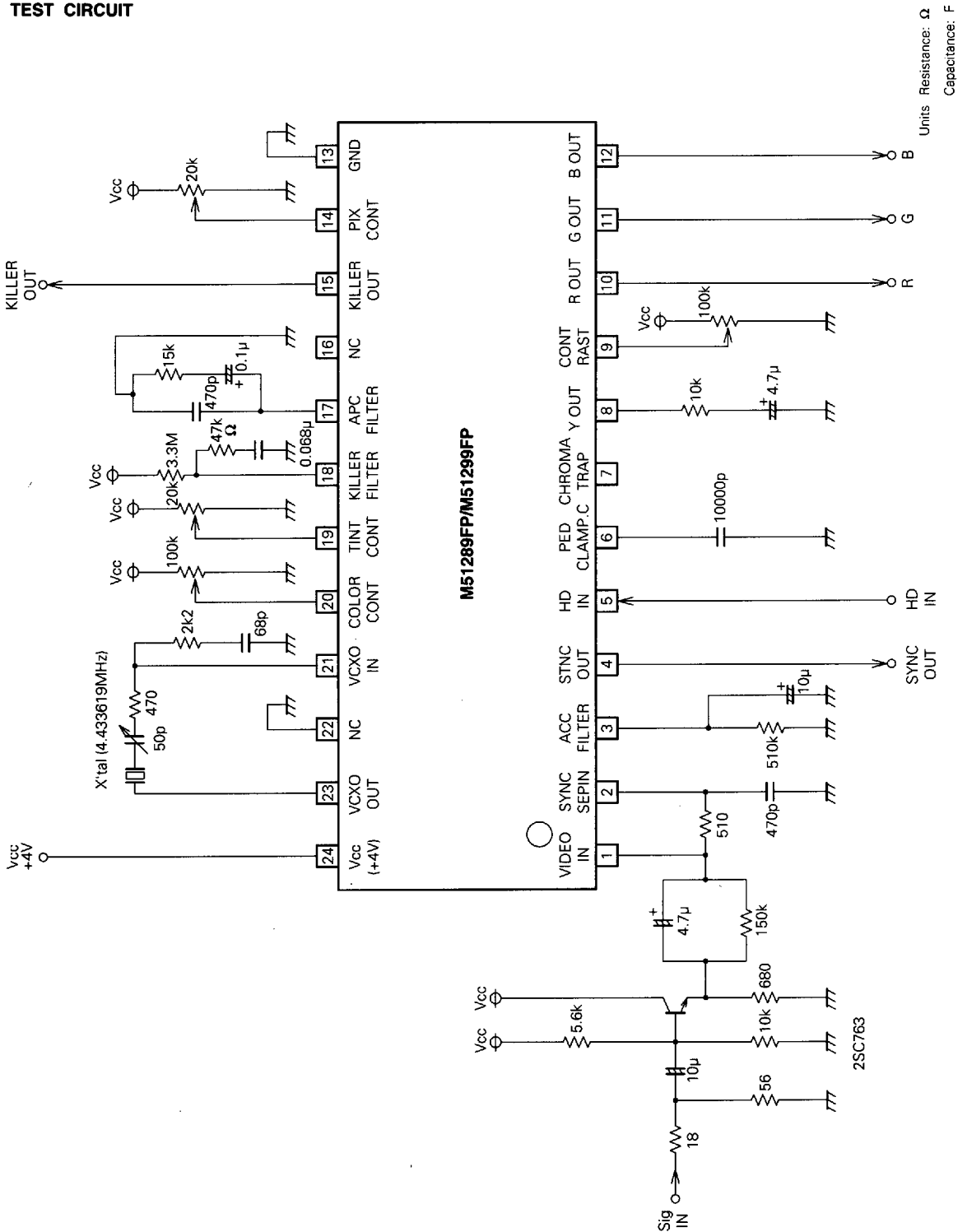

MITSUBISHI ELEK (LINEAR)

M51289FP/M51299FP

PAL VIDEO CHROMA SIGNAL PROCESSOR

---

TYPICAL CHARACTERISTICS

THERMAL DERATING (MAXIMUM RATING)

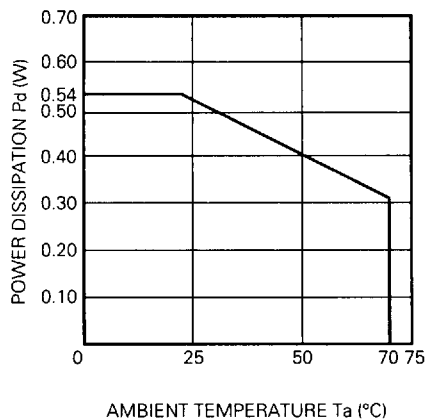

M51289FP/M51299FP

MITSUBISHI ELEK (LINEAR)

PAL VIDEO CHROMA SIGNAL PROCESSOR

APPLICATION EXAMPLE

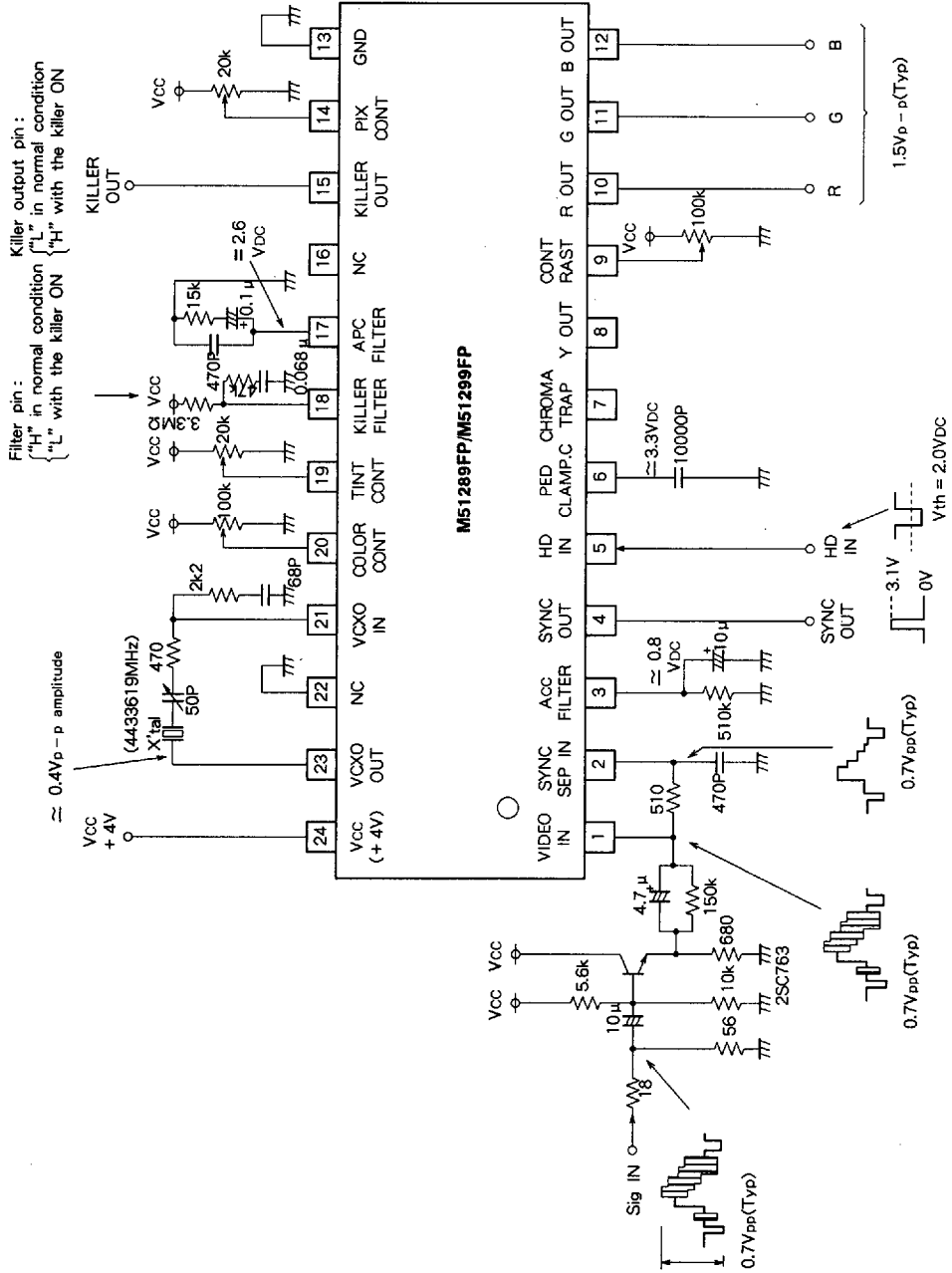

Units Resistance: Ω  
Capacitance: F

MITSUBISHI ELEK (LINEAR)

M51289FP/M51299FP

PAL VIDEO CHROMA SIGNAL PROCESSOR

DESCRIPTION OF PIN

Pin No.	Name	Peripheral circuit of pins
①	VIDEO IN	
②	SYNC SEP IN	
③	ACC FILTER	
④	SYNC OUT	



DESCRIPTION OF PIN (cont.)

Pin No.	Name	Peripheral circuit of pins
⑤	HD IN	
⑥	PED CLAMP C	
⑦	CHROMA TRAP	
⑧	Y OUT	

DESCRIPTION OF PIN (cont.)

Pin No.	Name	Peripheral circuit of pins
⑨	CONTRAST CONT.	
⑩	R OUT	
⑪	G OUT	
⑫	B OUT	
⑬	GND	—
⑳	Vcc +4V	—
⑰	N. C.	—
㉑		
⑭	PIX CONT.	
⑮	KILLER OUT	

DESCRIPTION OF PIN (cont.)

Pin No.	Name	Peripheral circuit of pins
⑰	APC FILTER	
⑱	KILLER FILTER	
⑲	TINT CONT.	
⑳	COLOR CONT.	

MITSUBISHI ELEK (LINEAR)

M51289FP/M51299FP

PAL VIDEO CHROMA SIGNAL PROCESSOR

DESCRIPTION OF PIN (cont.)

Pin No.	Name	Peripheral circuit of pins
⑳	VCXO IN	
㉑	VCXO OUT	