

M51494L

CORING NOISE REDUCTION

DESCRIPTION

The M51494L is a coring noise reduction circuit developed for the use to reduce noise in video signals.

This IC consists of a high frequency coring circuit, outline correction circuit, and output amp.

FEATURES

- Adjustable in setting of NR level (0 to 200 mV P-P input).
- Adjustable in setting of NR frequency band.
- Low distortion caused by NR, producing fine outline.
- Provided with both inverted and noninverted output.

APPLICATION

Video noise reduction circuit

RECOMMENDED OPERATING CONDITION

Rated supply voltage.....12 V

PIN CONFIGURATION (TOP VIEW)

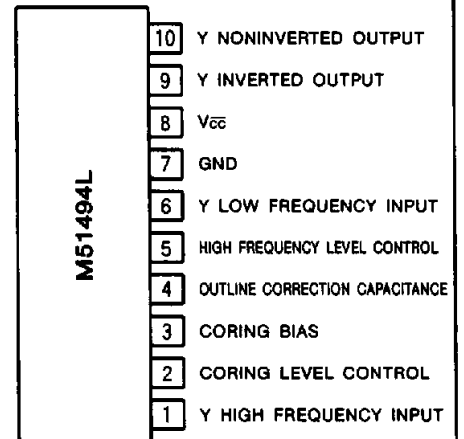

Outline 10P5

BLOCK DIAGRAM

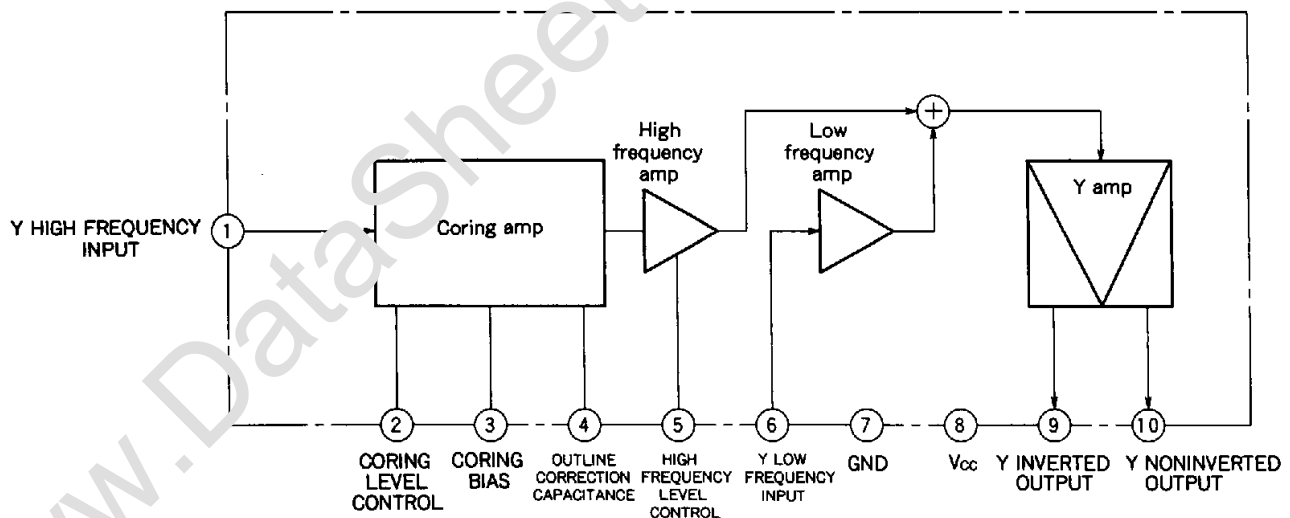

CORING NOISE REDUCTION

ABSOLUTE MAXIMUM RATINGS

Symbol	Parameter	Rated	Unit
V _{cc}	Supply voltage	14.4	V
P _d	Power dissipation	700	mW
K _θ	Thermal derating	7	mW/°C
T _{opr}	Operating temperature	-20~75	°C
T _{stg}	Storage temperature	-40~125	°C

ELECTRICAL CHARACTERISTICS (T_a=25°C, unless otherwise noted)

Symbol	Parameter	Test conditions	Limits			Unit
			Min.	Typ.	Max.	
V _{cc}	Operating supply voltage		10.5	12	14	V
I _{cc}	Circuit current		7	15	22	mA
G _{VH1}	High frequency amp gain (1)	SG : 1MHz, 100mVrms, V _{cor} , VHF=12V	15	16.5	18	dB
G _{VH2}	High frequency amp gain (2)	SG : 1MHz, 100mVrms, V _{cor} =12V, VHF=6V	8.4	10.4	12.4	dB
G _{VC}	Coring amp gain	SG : 1MHz, 100mVrms, V _{cor} =6V, VHF=12V	6.8	9.8	12.8	dB
G _{VL}	Low frequency amp gain	SG : 1MHz, 100mVrms	5.2	6.4	7.6	dB
G _{RO}	Inverted and noninverted output ratio		-1	0	+1	dB
V _{DR}	Output dynamic range	SG : 1MHz, 850mVrms	3.2	3.8	-	V _{P-P}

APPLICATION EXAMPLE

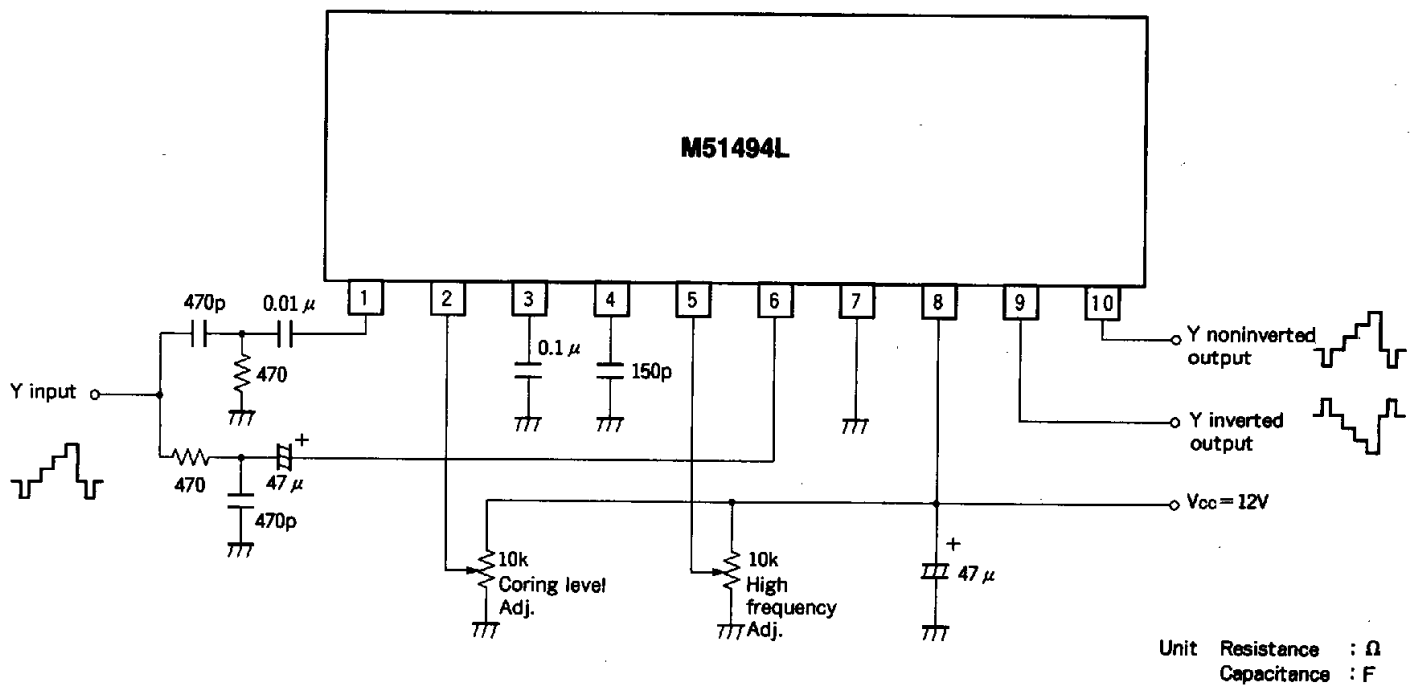

CORING NOISE REDUCTION

PRECAUTIONS FOR APPLICATION

About Coring Noise Reduction

The concept of this design is to reduce noise by cutting signals under a certain level contained in high frequency luminance signal components, noting the high frequency noise that can be a disturbance to the quality of image.

The operation is explained below using the Application Example. Luminance signals applied to the input pin are divided by LPF (low-pass filter) and HPF (high-pass filter) into two bands; each is applied to high frequency (pin ①) and low frequency (pin ⑥) inputs. In the application example the cut-off frequency for both LPF and HPF is set to approximately 700 kHz. Signals under a certain level contained in the high frequency components applied to pin ① are cut by the coring circuit. This cutting level can be adjusted by pin ②, coring level control, as shown in Figs 1 and 2. Signals passed through the coring circuit are output at pin ④ being corrected by the outline correction capacitance.

For better understanding of this operation, the figure below shows an example sine wave containing noise, inputted to pin ①. If the outline correction capacitance is not used, the signal output from pin ④ will be as illustrated by Fig. a, clearly showing the cutting of low level signals. By adding outline correction capacitance, waveforms are corrected as shown in Fig. b. Regarding the outline correction capacitance, make settings (input multiburst signals, for example) so that no waviness occurs in frequency characteristics. Note that this capacitance may limit high frequency band characteristics and dynamic range depending on its magnitude, so that care should be taken. Pin ③ is a bias pin for coring.

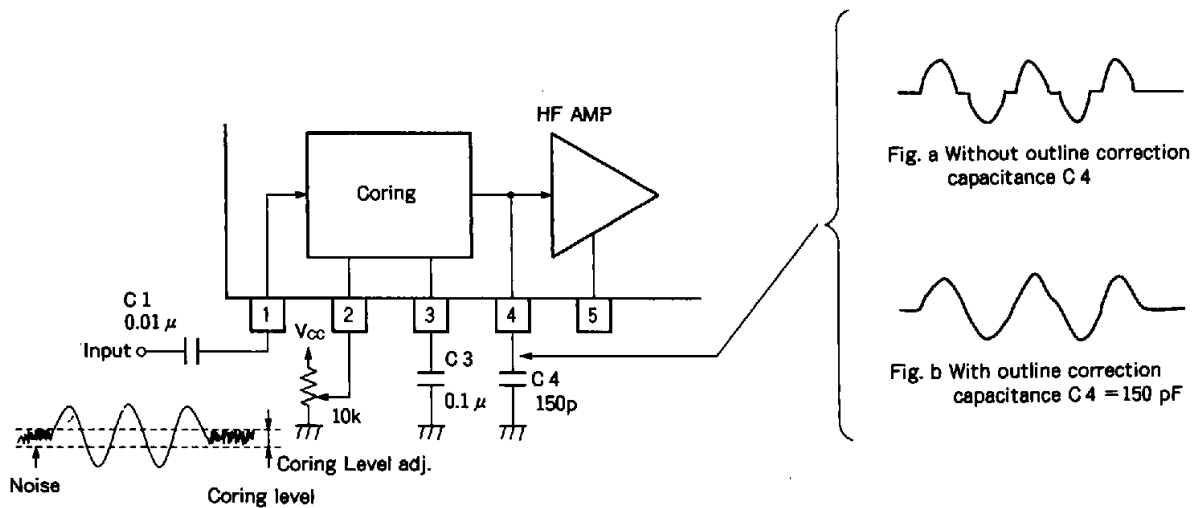

The cored and noise-reduced high frequency signal output from pin ④ passes through the high frequency amp (HF AMP) and is added to the low frequency signal from pin ⑥, then is output from pins ⑨ and ⑩. To adjust the level at which the high frequency signal is added, use the high frequency level control, pin ⑤. If addition of high frequency level is insufficient, the image will be blurred. If addition is much, the outline of image

will be emphasized, however, waviness will occur on frequency characteristics, so that care should be taken. It is recommended to control by means of, for example, multiburst signals.

The low frequency amp has an approximately 6 dB gain, so that the output amplitude at pins ⑨ and ⑩ is doubled compared with the Y input shown in the application example.

CORING NOISE REDUCTION

TYPICAL CHARACTERISTICS

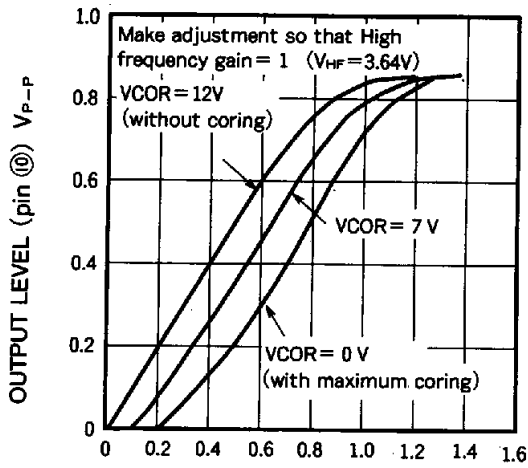

Fig. 1 High Frequency Input versus Output
 (difference caused by coring voltage)

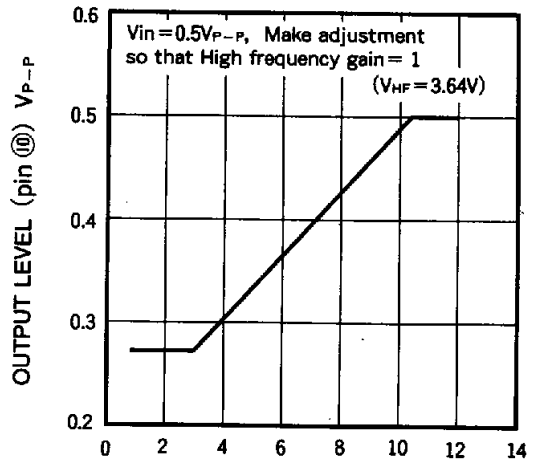

Fig. 2 Coring voltage versus Coring

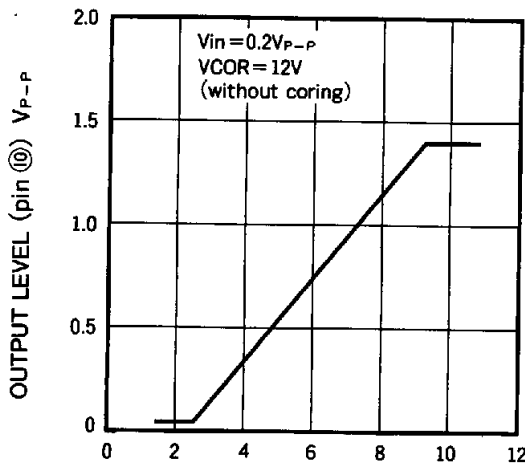

Fig. 3 High Frequency Level Control Characteristic

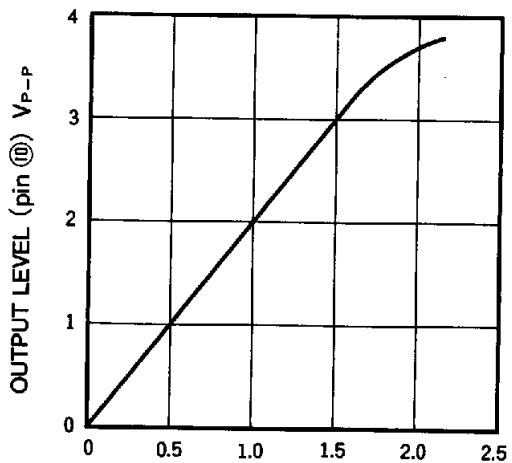

Fig. 4 Low Frequency Input/Output Characteristic