

M51598FP

PREAMPLIFIER FOR OPTICAL PICKUP

DESCRIPTION

The M51598FP is an optical pickup preamplifier for CD players. It has a built-in I-V amplifiers that convert current signals gained by photodetectors into voltage signals and HF (high frequency) mixing, FE (focus error), and TE (tracking error) amplifiers, as well as HF signal detector and mirror detector.

FEATURES

- For 3 laser system
- Capable of being driven by either single or dual power supply
- Built-in LPF ($f_c = 70\text{kHz}$) for TE and FE amplifiers
- E-F balance control pin (pin ③)
- Built-in focus error balance control pin (pin ⑩)
- External components.....as few as 2 chemical capacitors, 3 ceramic capacitors, 2 volume controls, and 1 resistor
- Built-in microminiature 24-pin flat package (0.8mm lead pitch)

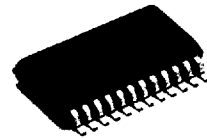

Outline 24P2Q-A

0.8mm pitch 300mil SSOP
(5.3mm × 10.1mm × 1.8mm)

RECOMMENDED OPERATING CONDITIONS

Supply voltage range..... $V_{CC} = 4.75 \sim 5.25\text{V}$
 Rated supply voltage..... $V_{CC} = 5\text{V}$
 Rated power dissipation.....85mW

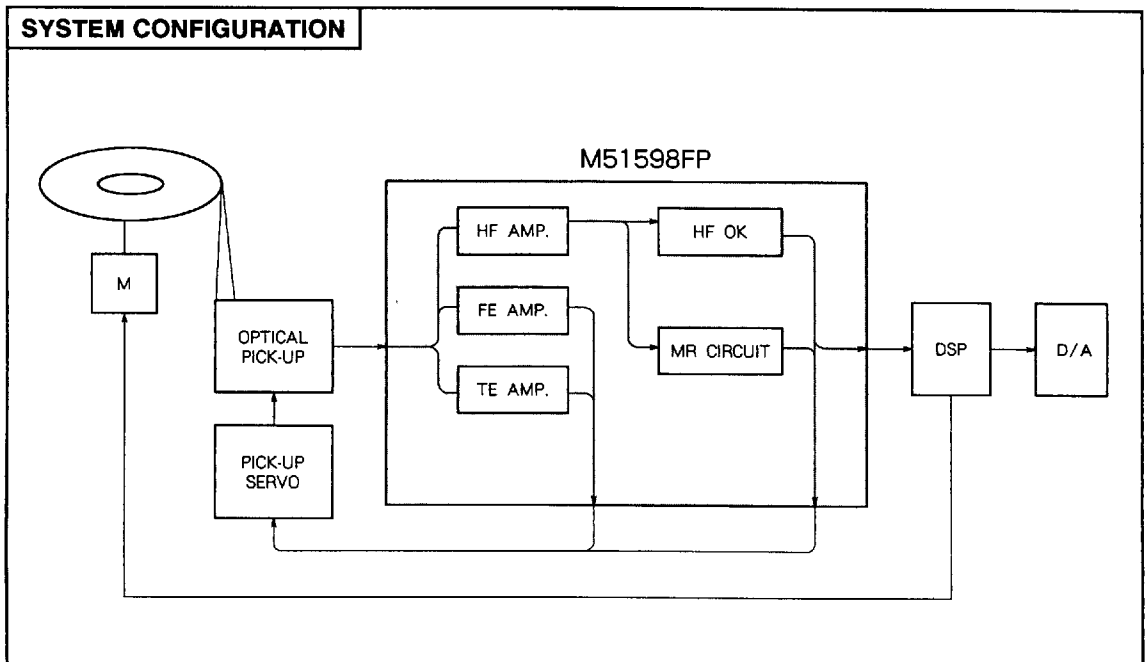

PIN CONFIGURATION

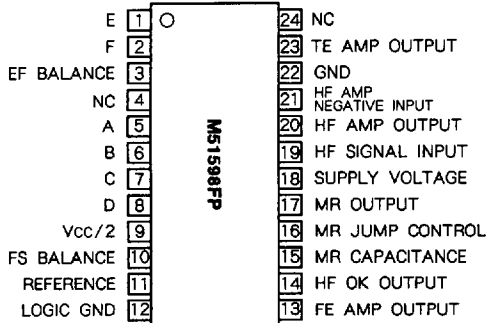

Outline 24P2Q-A

NC : NO CONNECTION

IC INTERNAL BLOCK DIAGRAM

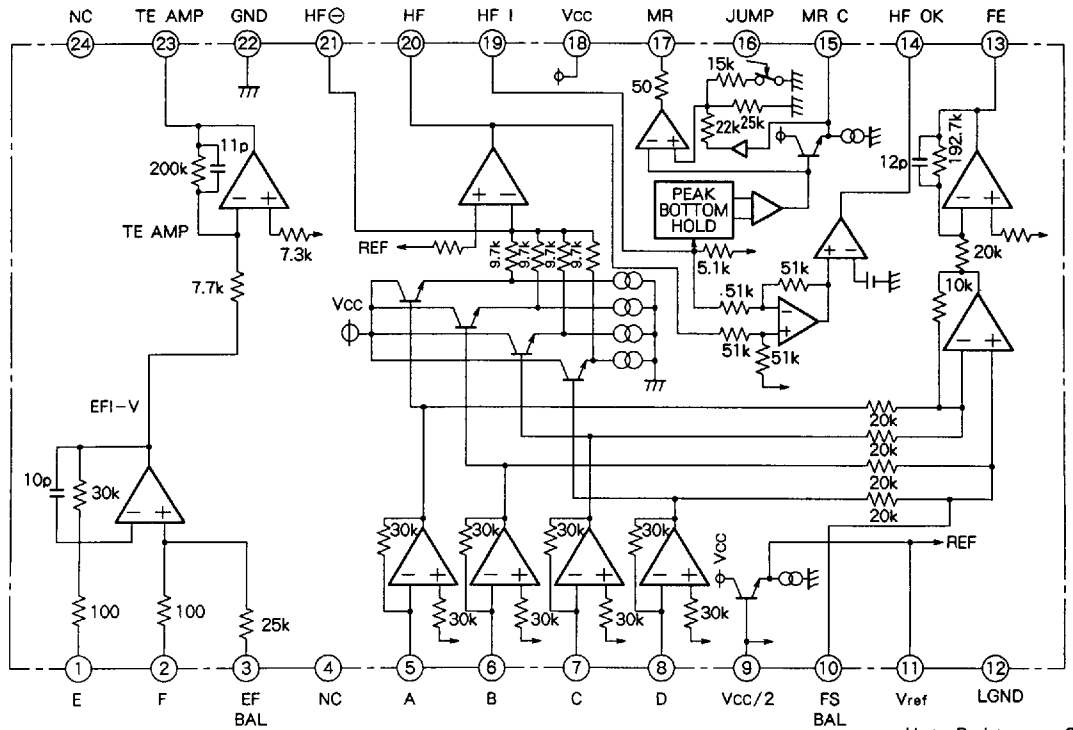

Internal component values are typical

Units Resistance : Ω
Capacitance : F

ABSOLUTE MAXIMUM RATINGS (Ta = 25°C, unless otherwise noted)

Symbol	Parameter	Ratings	Unit
Vcc	Supply voltage	10	V
Icc	Circuit current	40	mA
Vi	Input voltage	0~Vcc	V
Vo	Output voltage	0~Vcc	V
Pd	Power dissipation	540	mW
Topr	Operating temperature	-20~+75	°C
Tstg	Storage temperature	-40~+125	°C

ELECTRICAL CHARACTERISTICS (Ta = 25°C, Vcc = 5V)

Symbol	Block	Parameter	Test conditions	Limits			Unit
				Min	Typ	Max	
Icc		Circuit current	No signal	-	15	33	mA
GVHF	H F	HF output voltage	A~D input f=500kHz, Vi = 78mVp-p	0.9	1.1	1.3	Vp-p
fHF		HF frequency	A~D input f=2MHz, Vi=65mVp-p	-5	-2	-	dB
VOHA		HF High output voltage		3.8	4.2	-	V
VOHF		HF output offset voltage	Input open	-120	0	+120	mV
GVFE	F E	FE output voltage	A, C input f=500kHz, Vi=78mVp-p	0.5	0.7	0.9	Vp-p
VHAC		HF High output voltage	RL = 10kΩ	3.6	4.1	-	V
VLAC		HF Low output voltage	RL = 10kΩ	-	0.5	1.2	V
VOFE		Output offset voltage	Input open	-50	0	+50	mV
GVTE	T E	TE output voltage	E input f=1kHz Vi=38.4mVp-p	0.7	1.0	1.3	Vp-p
VHTE		TE High output voltage	RL=10kΩ	3.6	4.1	-	V
VLE		TE Low output voltage	RL=10kΩ	-	0.5	1.2	V
VOTTE		Output offset voltage	Input open	-100	0	+100	mV
VHOK	H F O K	HFOK High output voltage		3.5	4.1	-	V
VLOK		HFOK Low output voltage	No signal	-	0	0.4	V
VTHK		Threshold voltage		0.26	0.37	0.48	V
VHMR	M R	MR High output voltage	No signal	3.5	4.1	-	V
VLMR		MR Low output voltage		-	0	0.4	V
VTHN		Envelope ratio (normal)	f = 500kHz (carrier)	0.26	0.36	0.46	-
VTHJ		Envelope ratio (jump)	f = 500kHz (carrier)	0.5	0.6	0.7	-
fMRf		MR frequency	f = 500kHz (carrier), AM mod=55%	47	60	-	kHz

PREAMPLIFIER FOR OPTICAL PICKUP

TYPICAL CHARACTERISTICS

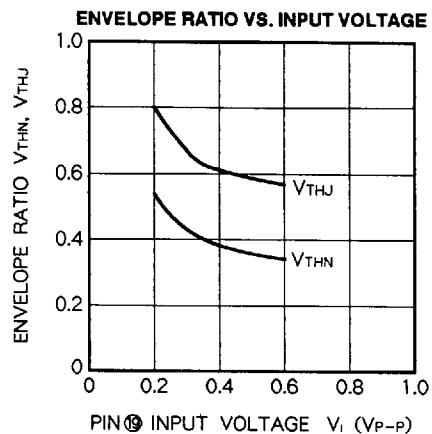
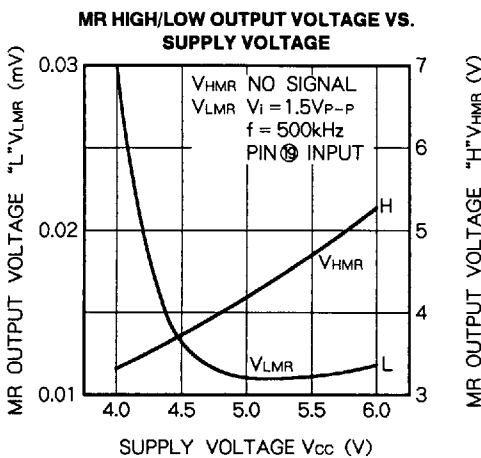
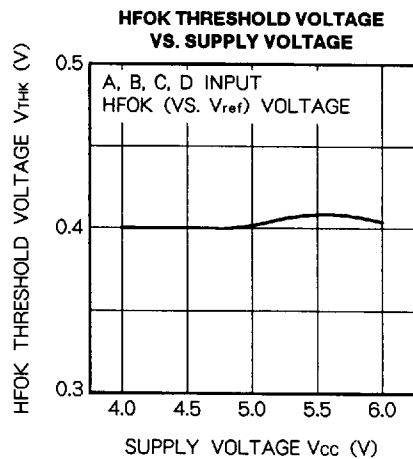
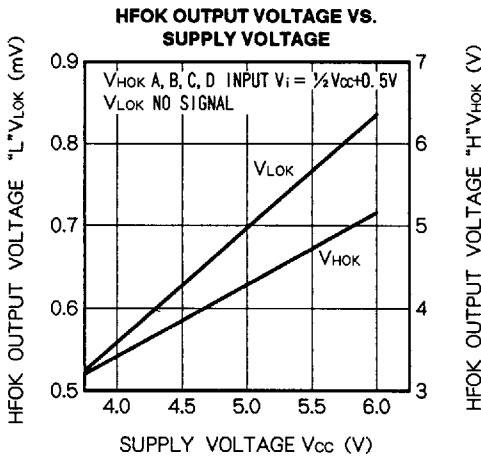
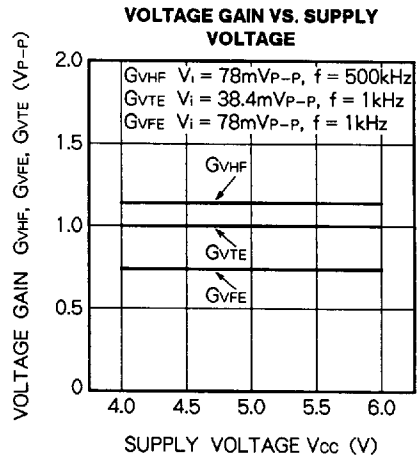
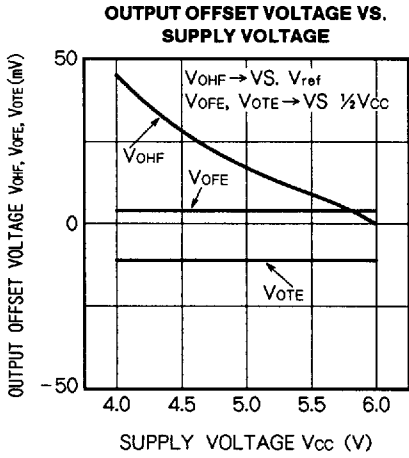

M51598FP

PREAMPLIFIER FOR OPTICAL PICKUP

APPLICATION EXAMPLE

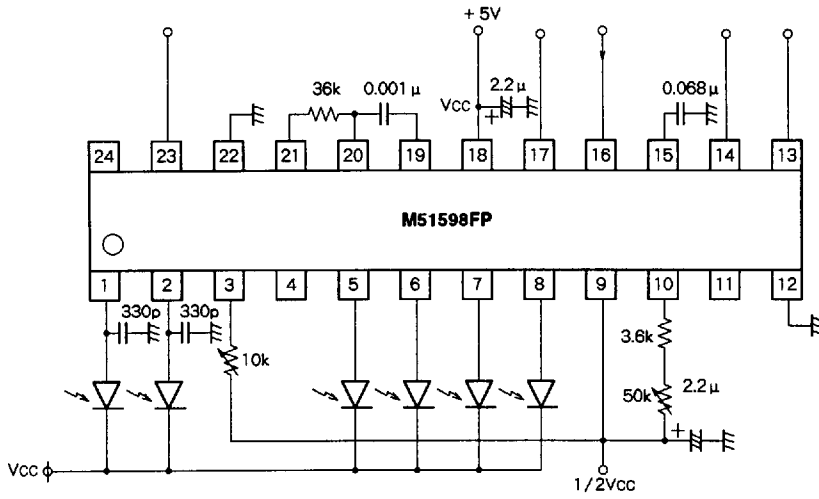

Internal component values are typical.

Units Resistance : Ω
Capacitance : F