

M5227P/FP**Hi-Fi 5-ELEMENT GRAPHIC EQUALIZER IC****DESCRIPTION**

The M5227 is a 5-element graphic equalizer IC best suited to Hi-Fi audio systems. It has 5-element resonance circuits with OP amp system and an output OP amp.

The IC can be used in compact sets of high-density assemblies, modules, and hybrid ICs. Its applications cover Hi-Fi stereo sets, radio cassette tape players, car audio systems, music centers, and electronic musical instruments.

FEATURES

- High withstand voltage and wide supply voltage range
..... $V_{CC} = \pm 2$ to $\pm 18V$ (4 to 36V)
- Low distortion THD = 0.002% (typ)
@ $f = 1kHz$, Flat, $V_o = 5V_{rms}$
- Low noise $V_{No} = 6\mu V_{rms}$ (typ)
@ Flat input short
- Variable G_v by external resistance $G_v = \pm 12dB$ (typ)
- Single power (use GND pin⑨ for $V_{CC}/2$)
- Large allowable input voltage $V_{IM} = 9.5V_{rms}$ (typ)
@ $f = 1kHz$, THD = 1%, Flat

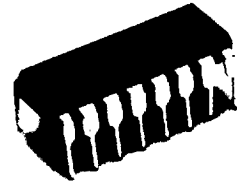

Outline 16P4(P)

2.54mm pitch 300mil DIP
(6.3mm × 19.0mm × 3.3mm)

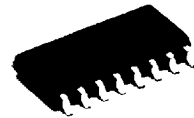

Outline 16P2S-A(FP)

1.27mm pitch 225mil SOP
(4.4mm × 10.0mm × 1.5mm)

RECOMMENDED OPERATING CONDITIONS

- Supply voltage range $V_{CC}, V_{EE} = \pm 2$ to $\pm 18V$
or $V_{CC} = 4$ to 36V
- Rated supply voltage $V_{CC}, V_{EE} = \pm 15V$ or $V_{CC} = 30V$
- Rated power dissipation 1000mW(P)
550mW(FP)

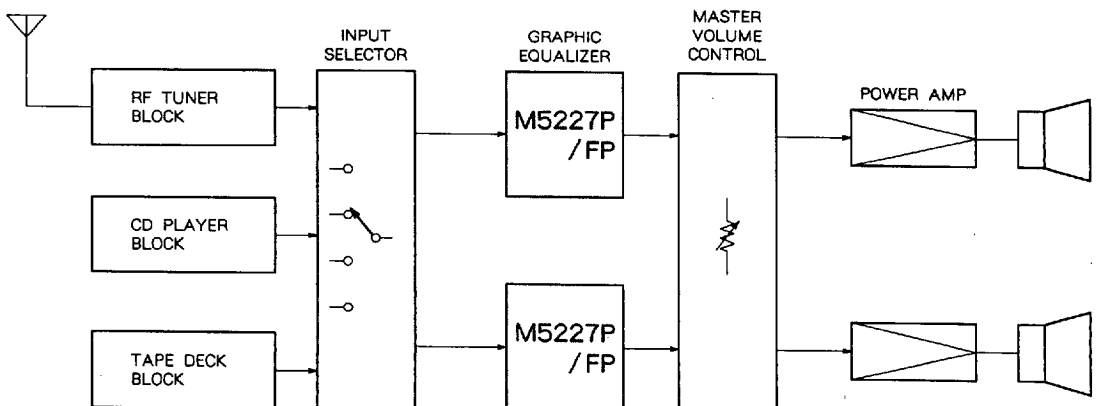
SYSTEM CONFIGURATION

M5227P/FP

HI-FI 5-ELEMENT GRAPHIC EQUALIZER IC

PIN CONFIGURATION (TOP VIEW)

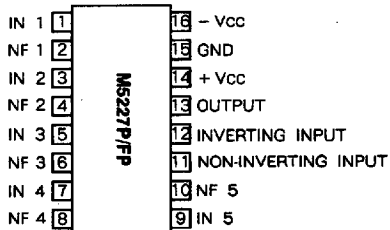

Outline 16P4(P)
16P2S-A(FP)

IC INTERNAL BLOCK DIAGRAM

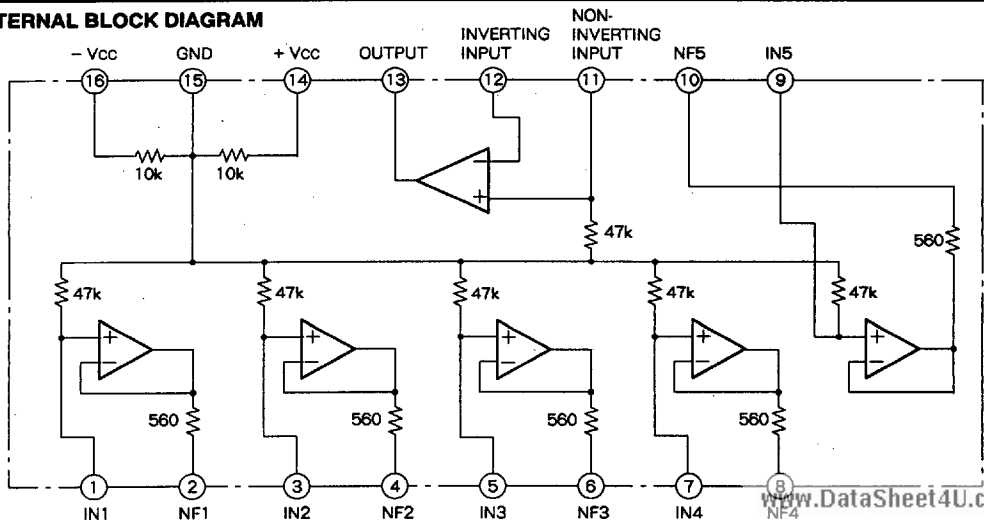

HI-FI 5-ELEMENT GRAPHIC EQUALIZER IC

ABSOLUTE MAXIMUM RATINGS (Ta = 25 °C, unless otherwise noted)

Symbol	Parameter	Ratings	Unit
Vcc	Supply voltage	36(± 18)	V
ILP	Load current	50	mA
Pa	Power dissipation	1000(DIP)/550(FP)	mW
Topr	Operating temperature	- 20 to + 75	°C
Tstg	Storage temperature	- 55 to + 125	°C

ELECTRICAL CHARACTERISTICS (Ta = 25 °C, Vcc = ± 15V)

Symbol	Parameter	f (Hz)	Test Conditions	Limits			Unit
				Min	Typ	Max	
Icc	Circuit current	-	Vin = 0	6	9	12	mA
Gv(FLAT)	Voltage gain flat	1k	Vin = - 10dBm	- 2.3	- 0.3	+ 1.7	dB
Gv(BOOST)	Voltage gain boost (Response)	108	Vin = - 10dBm Vo(FLAT) = 0dB	9.5	12.0	13.5	dB
		343		9.5	12.0	13.5	
		1.08k		9.5	12.0	13.5	
		3.43k		9.5	12.0	13.5	
		10.8k		9.5	12.0	13.5	
Gv(CUT)	Voltage gain cut (Response)	108	Vin = - 10dBm Vo(FLAT) = 0dB	- 13.5	- 12.0	- 9.5	dB
		343		- 13.5	- 12.0	- 9.5	
		1.08k		- 13.5	- 12.0	- 9.5	
		3.43k		- 13.5	- 12.0	- 9.5	
		10.8k		- 13.5	- 12.0	- 9.5	
THD	Distortion ratio	1k	Vin = 5Vrms Flat	-	0.002	0.1	%
Vno	Output noise voltage		Input short BW : 10Hz to 30kHz Flat	-	6	25	µVrms
Vom	Maximum output voltage	1k	THD = 1 %, Flat	7	9.5	-	Vrms

TYPICAL CHARACTERISTICS

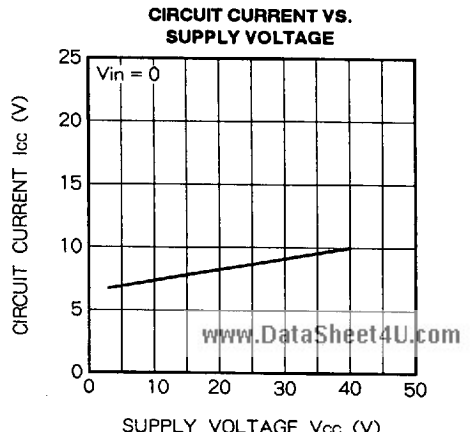
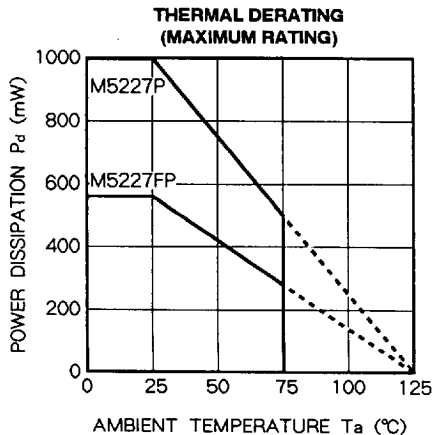

M5227P/FP

HI-FI 5-ELEMENT GRAPHIC EQUALIZER IC

APPLICATION EXAMPLE (Standard)

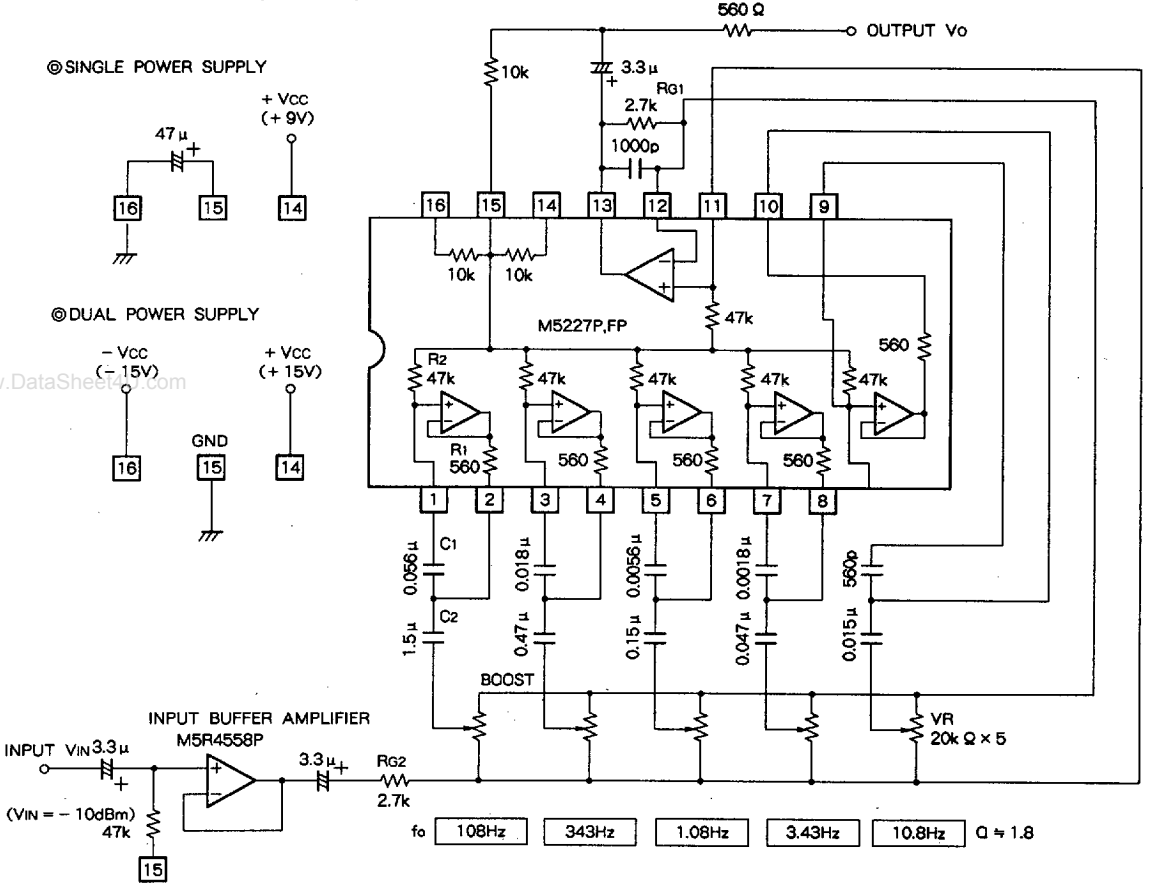

$$\text{RESONANCE FREQUENCY } f_o = \frac{1}{2 \pi \sqrt{C_1 \cdot C_2 \cdot R_1 \cdot R_2}} \text{ (Hz)} \quad Q = \sqrt{C_1 \cdot R_2 / C_2 \cdot R_1}$$

Units Resistance : Ω
Capacitance : F

FREQUENCY CHARACTERISTICS

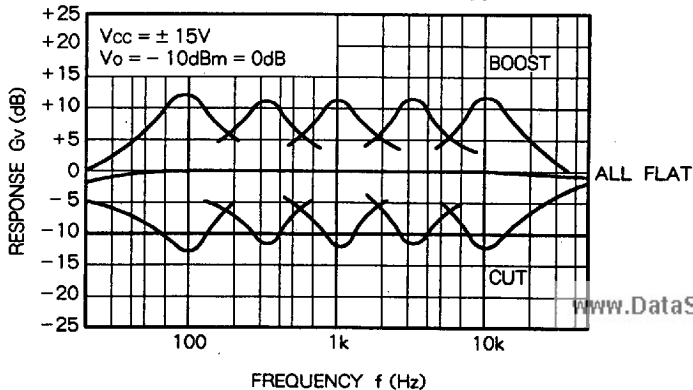

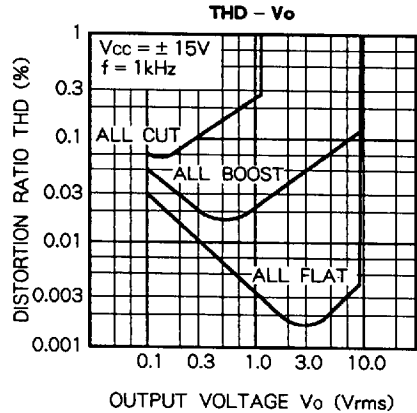
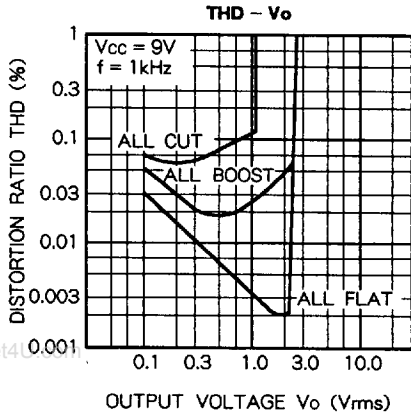

OPERATION DESCRIPTION

The M5227P consists of 5 resonance circuits and an output amplifier, and can also form a graphic equalizer, which has optional resonance frequency f_0 , by the externally connecting condenser C_1 , C_2 of variable resistance and a resonance circuit. The impedance is minimized by resonating and the semiconductor, which is adopted in the resonance circuit, can therefore vary the frequency gain.

1. Flat boost cut

The resonance frequency gain can be altered by varying the external variable register.

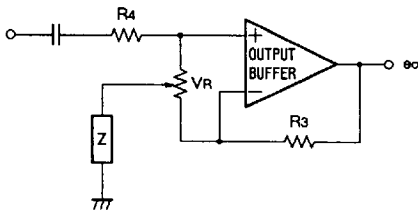

Z is an impedance in the resonance circuit

(1) Flat

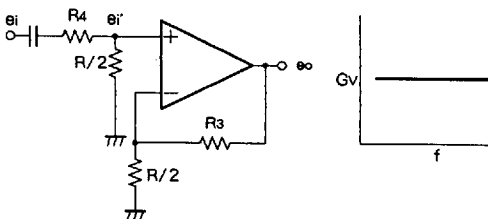

R/2 is resistance at the center of VR

When the variable register is in center position, the equivalent circuit as in the above diagram can be obtained. At this stage if R_3 , R_4 are set at the same level of resistance, then

$$e_i' = \frac{R/2}{R_4 + R/2} \cdot e_i, \quad A_v = \frac{R_3 + R/2}{R/2}$$

$$e_o = A_v \cdot e_i' = e_i$$

and, the frequency characteristics will be level regardless of the resonance circuit.

(2) Boost

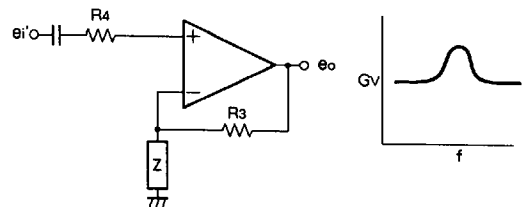

When the variable register is in boost position, the resonance circuit is connected to the NF loop of the output buffer amplifier. At this stage, R is much smaller than R_3 , R_4 , so it can be disregarded.

The gain A_v is
$$A_v = \frac{R_3 + 4}{Z} \text{ and,}$$

the output voltage e_o is
$$e_o = A_v \cdot e_i = \frac{R_3 + Z}{Z} \cdot e_i$$

When Z is smallest, the gain in resonance is the greatest, and the optional frequency is then boosted.

(3) Cut

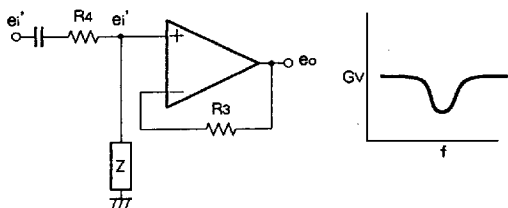

When the variable register is in cut position, the resonance circuit is connected to the input side of the output buffer amplifier. When R is disregarded as the boost.

$$e_i' = \frac{Z}{R_4 + Z} \cdot e_i, \quad A_v = 1 \quad \text{and}$$

$$\text{the output voltage } e_o \text{ is } e_o = A_v \cdot e_i' = \frac{Z}{R_4 + Z} \cdot e_i$$

When Z is smallest, the gain in resonance is the greatest, and the optional frequency is then cut.

2. Resonance circuit

The semiconductor inductor converts L in the R, L, C serial resonance circuit into a CR pin by the buffer functions of active pins such as registers, operational amplifiers, and works in almost the same way as the R, L, C serial resonance circuit.

The R, L, C resonance frequency

$$f_0 \text{ is } f_0 = 1/2 \pi \sqrt{LC} \dots \dots \dots \text{Equation No. 1}$$

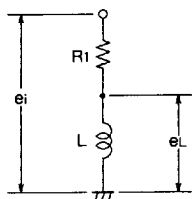

Fig. 1

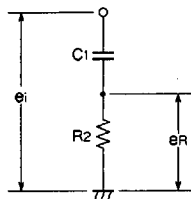

Fig. 2

When the voltage e_i is supplied to the resonance circuit as shown in Fig. 1, $e_L = j \omega L \cdot e_i / (R_1 + j \omega L)$

If e_i is then supplied to the pins C_1, R_2 as shown in Fig. 2, When $e_L = e_R, L = C_1 \cdot R_1 \cdot R_2 \dots \dots \dots$ Equation No. 2

But, if e_R is replaced by L of the R and L serial circuit, R_1 and C_1 are automatically connected in a parallel manner, and the value of e_R will be changed. So, in order to keep the value of e_R stable, a buffer amplifier should be used. The buffer amplifier is equivalent to an impedance.

By equations 1 and 2, the resonance frequency, f_0 is $f_0 = 1/2 \pi \sqrt{C_1 \cdot C_2 \cdot R_1 \cdot R_2}$

The buffer amplifier in the resonance circuit of the M5227 is composed of operational amplifiers.

3. Angle of maximum resonance

The angle of maximum resonance, Q, is defined by the ratio of ω_0 ($\omega_0 = 2 \pi f_0$) and the frequency band width, $\omega_2 - \omega_1$, ($G_{max} / \sqrt{2}$).

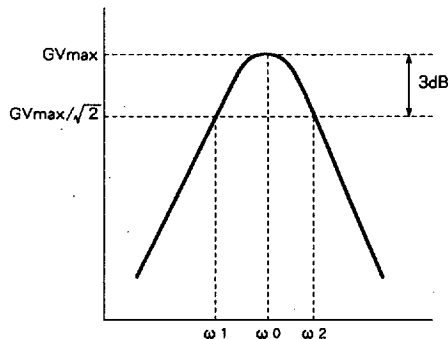

The value of Q is found by the following equation :

$$Q = \sqrt{C_1 \cdot R_2 / C_2 \cdot R_1}$$

The greater the value of Q, the narrower the frequency band width, and vice versa.

The M5227 is composed of R_1, R_2 , so Q is defined by selecting the external condenser.