

## M52334FP

### PLL-Split VIF/SIF IC

REJ03F0164-0201

Rev.2.01

Jan 25, 2008

#### Description

The M52334FP is IF signal-processing IC for VCRs and TVs. It enables the PLL detection system despite size as small as that of conventional quasi-synchronous VIF/SIF detector, IF/RF AGC, SIF limiter and FM detector.

#### Features

- Video detection output is 2 V<sub>p-p</sub>. It has built-in EQ AMP.
- The package is a 20-pin flat package, suitable for space saving.
- The video detector uses PLL for full synchronous detection circuit. It produces excellent characteristics of DG, DP, 920 kHz beat, and cross color.
- Dynamic AGC realizes high-speed response with only single filter.
- Video IF and sound IF signal processing are separated from each other. VCO output is used to obtain intercarrier.
- As AFT output voltage uses the APC output voltage, VCO coil is not used.
- Audio FM demodulation uses PLL system, so it has wide frequency range with no external parts and no adjustment.
- This IC corresponds to only inter of NTSC system.

#### Application

TV sets, VCR tuners

#### Recommended Operating Condition

- In case of V<sub>CC</sub> and V<sub>reg</sub>. OUT short
  - Supply voltage range: 4.75 to 5.25 V
  - Recommended supply voltage: 5.0 V
- In case of V<sub>reg</sub>. OUT open
  - Supply voltage range: 8.5 to 12.5 V

### Block Diagram

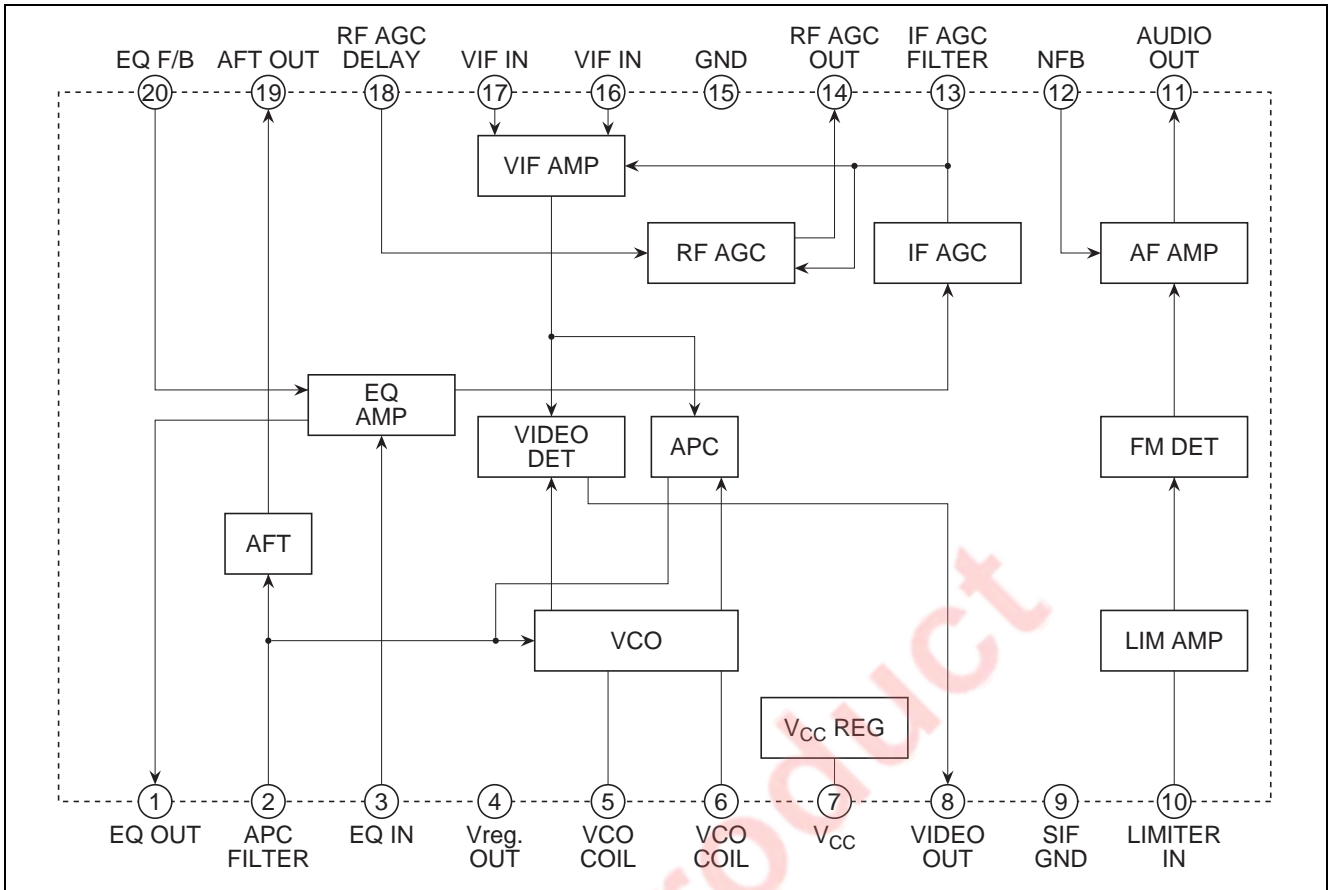

### Pin Arrangement

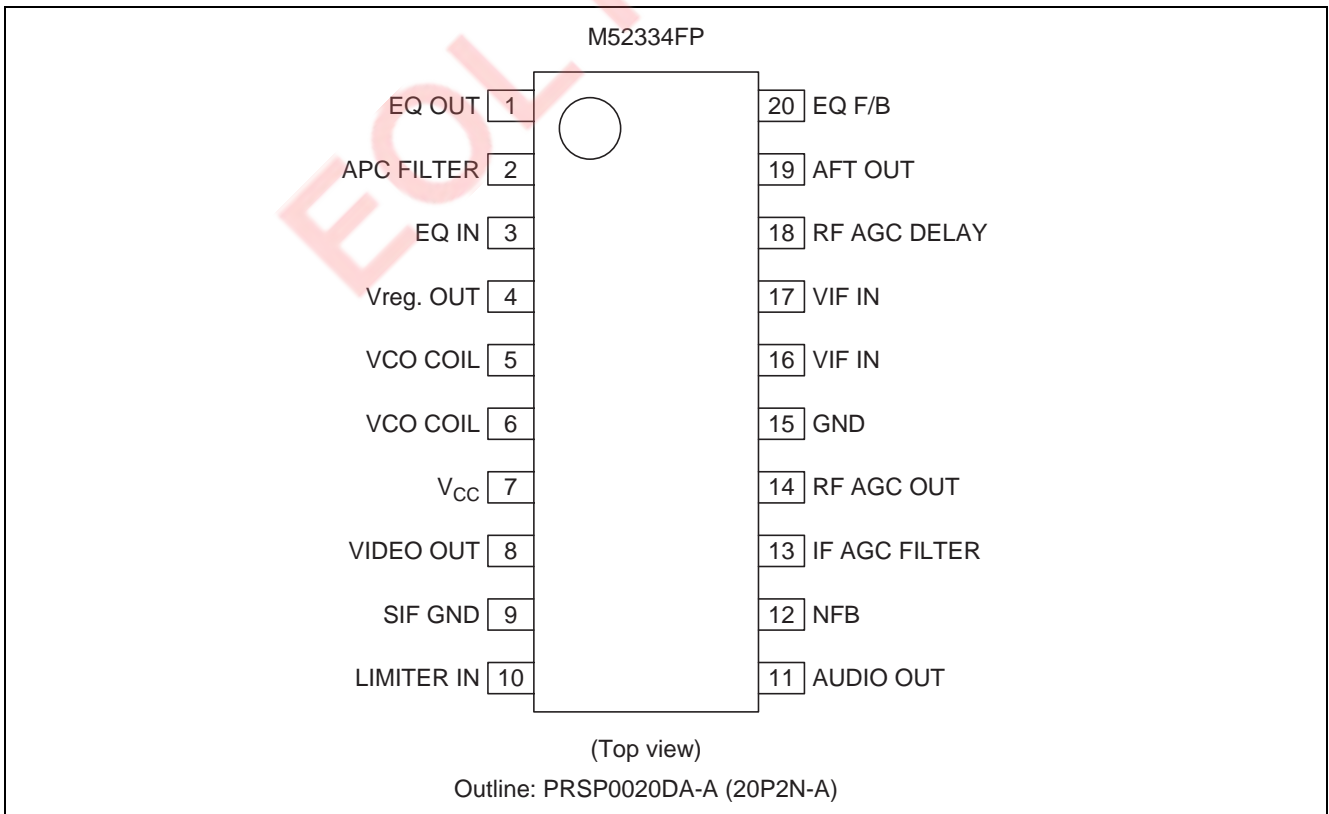

## Absolute Maximum Ratings

(Ta = 25°C, unless otherwise noted)

Item	Symbol	Ratings	Unit	Condition
Supply voltage1	V <sub>CC</sub>	13.2	V	V <sub>CC</sub> and V <sub>reg. out</sub> is not connected to each other.
Supply voltage V <sub>reg. OUT</sub>	V <sub>reg. OUT</sub>	6.0	V	V <sub>CC</sub> and V <sub>reg. out</sub> is not connected to each other.
Power dissipation	P <sub>d</sub>	1225	mW	
Operating temperature	T <sub>opr</sub>	-20 to +85	°C	
Storage temperature	T <sub>stg</sub>	-40 to +150	°C	
Surge voltage resistance	Surge	200	V	Surge protection capacitance 200 pF resistance 0

## Electrical Characteristics

(V<sub>CC</sub> = 9 V, Ta = 25°C, unless otherwise noted.)

Item	Symbol	Test Circuit	Test Point	Input Point	Input SG	Limits			Unit	Test Conditions Switches set to position 1 unless otherwise indicated
						Min	Typ	Max		
VIF section										
Circuit current1 V <sub>CC</sub> = 5V	I <sub>CC1</sub>	1	A	—	—	33	40.5	47	mA	V <sub>CC</sub> = 5 V SW4 = 2, SW7 = 2
Circuit current2 V <sub>CC</sub> = 12V	I <sub>CC2</sub>	1	A	—	—	31	40.5	49	mA	V <sub>CC</sub> = 12 V SW7 = 2
V <sub>reg</sub> voltage2	V <sub>CC2</sub>	1	TP4	—	—	4.7	5.00	5.3	V	V <sub>CC</sub> = 12 V
Video output DC voltage1	V1	1	TP1A	—	—	3.45	3.9	4.35	V	SW13 = 2 V13 = 0 V
Video output voltage8	V <sub>o det8</sub>	1	TP8	VIF IN	SG1	0.85	1.1	1.35	V <sub>p-p</sub>	
Video output voltage1	V <sub>o det</sub>	1	TP1A	VIF IN	SG1	1.85	2.2	2.55	V <sub>p-p</sub>	
Video S/N	Video S/N	1	TP1B	VIF IN	SG2	51	56	—	dB	SW1 = 2
Video band width	BW	1	TP1A	VIF IN	SG3	5.0	7.0	—	MHz	SW13 = 2 V13 = variable
Input sensitivity	VIN MIN	1	TP1A	VIF IN	SG4	—	48	52	dB <sub>μ</sub>	
Maximum allowable input	VIN MAX	1	TP1A	VIF IN	SG5	101	105	—	dB <sub>μ</sub>	
AGC control range input	GR	—	—	—	—	50	57	—	dB	
IF AGD voltage	V13	1	TP13	VIF IN	SG6	2.85	3.15	3.45	V	
Maximum IF AGC voltage	V13H	1	TP13	—	—	4.0	4.4	—	V	
Minimum IF AGC voltage	V13L	1	TP13	VIF IN	SG7	2.2	2.4	2.6	V	
Maximum RF AGC voltage	V14H	1	TP14	VIF IN	SG2	8.0	8.7	—	V	SW13 = 2 V13 = 4 V
Minimum RF AGC voltage	V14L	1	TP14	VIF IN	SG2	—	0.1	0.5	V	SW13 = 2 V13 = 1 V

(V<sub>CC</sub> = 9 V, T<sub>a</sub> = 25°C, unless otherwise noted.)

Item	Symbol	Test Circuit	Test Point	Input Point	Input SG	Limits			Unit	Test Conditions Switches set to position 1 unless otherwise indicated
						Min	Typ	Max		
RF AGC operation voltage	V14	1	TP14	VIF IN	SG8	86	89	92	dB $\mu$	
Capture range U	CL-U	1	TP1A	VIF IN	SG9	0.8	1.3	—	MHz	
Capture range L	CL-L	1	TP1A	VIF IN	SG9	1.4	2.0	—	MHz	
Capture range T	CL-T	1	—	—	—	2.5	3.3	—	MHz	
AFT sensitivity		1	TP19	VIF IN	SG10	20	30	70	mV/kHz	
AFT maximum voltage	V19H	1	TP19	VIF IN	SG10	7.7	8.2	—	V	
AFT minimum voltage	V19L	1	TP19	VIF IN	SG10	—	0.7	1.2	V	
AFT defeat 1	AFT def1	1	TP19	VIF IN	—	4.2	4.5	4.8	V	
Inter modulation	IM	1	TP3A	VIF IN	SG11	35	42	—	dB	SW13 = 2 V13 = variable
Differential gain	DG	1	TP3A	VIF IN	SG12	—	2	5	%	
Differential phase	DP	1	TP3A	VIF IN	SG12	—	2	5	deg	
Sync. tip level	V3 SYNC	1	TP3A	VIF IN	SG2	1.0	1.4	1.8	V	
VIF input resistor	RINV	2	TP17	—	—	—	1.2	—	k $\Omega$	
VIF input capacitance	CINV	2	TP17	—	—	—	5	—	pF	
SIF section										
AF output DC voltage	V1	1	TP11	—	—	3.5	4.4	5.3	V	
AF output	VoAF	1	TP11	SIF IN	SG16	565	790	1125	mVrms	
AF output distortion	THD AF	1	TP11	SIF IN	SG16	—	0.4	0.9	%	
Limiting sensitivity	LIM	1	TP11	SIF IN	SG17	—	42	55	dB $\mu$	
AM rejection	AMR	1	TP11	SIF IN	SG18	55	65	—	dB	
AF S/N	AF S/N	1	TP11	SIF IN	SG19	55	65	—	dB	

## Electrical Characteristics Test Method

### Video S/N

Input SG2 into VIF IN and measure the video out (Pin 3) noise in r.m.s at TP3-B through a 5 MHz (–3 dB) L.P.F.

$$S/N = 20 \log \left( \frac{0.7 \cdot V_o \text{ det}}{\text{NOISE}} \right) \text{ (dB)}$$

### BW Video Band Width

1. Measure the 1 MHz component level of EQ output TP3A with a spectrum analyzer when SG3 ( $f_2 = 44.75$  MHz) is input into VIF IN. At that time, measure the voltage at TP13 with SW13, set to position 2, and then fix V13 at that voltage.
2. Reduce  $f_2$  and measure the value of  $(f_2 - f_0)$  when the  $(f_2 - f_0)$  component level reaches –3 dB from the 1 MHz component level as shown below.

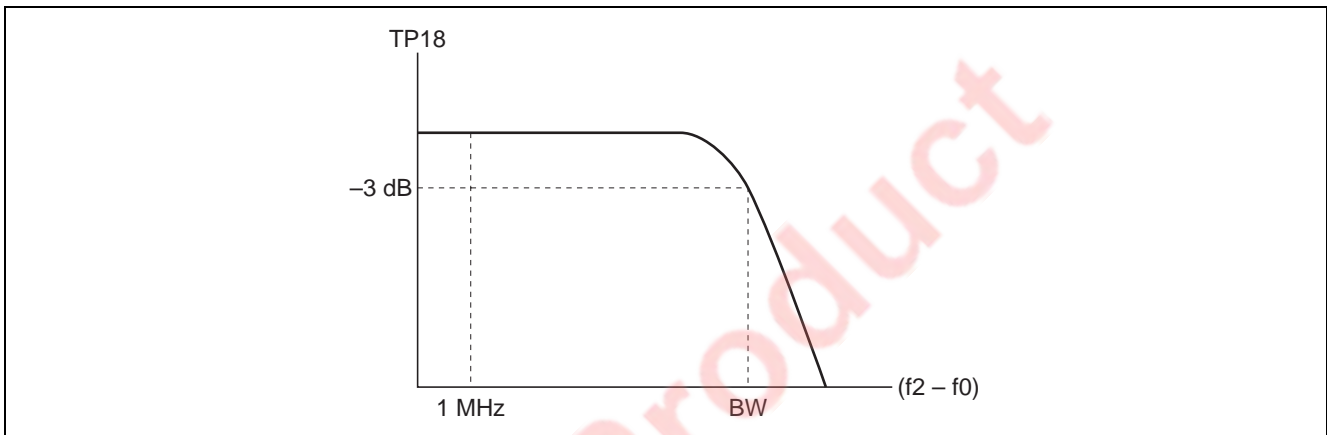

### VIN MIN Input Sensitivity

Input SG4 ( $V_i = 90$  dB $\mu$ ) into VIF IN, and then gradually reduce  $V_i$  and measure the input level when the 20 kHz component of EQ output TP3A reaches –3 dB from  $V_o$  det level.

### VIN MAX Maximum Allowable Input

1. Input SG5 ( $V_i = 90$  dB $\mu$ ) into VIF IN, and measure the level of the 20 kHz components of EQ output.
2. Gradually increase the  $V_i$  of SG and measure the input level when the output reaches –3 dB.

### GR AGC Control Range

$$GR = \text{VIN MAX} - \text{VIN MIN} \text{ (dB)}$$

### V18 RF AGC Operating Voltage

Input SG8 into VIF IN, and gradually reduce  $V_i$  and then measure the input level when RF AGC output TP14 reaches  $1/2 V_{CC}$ , as shown below.

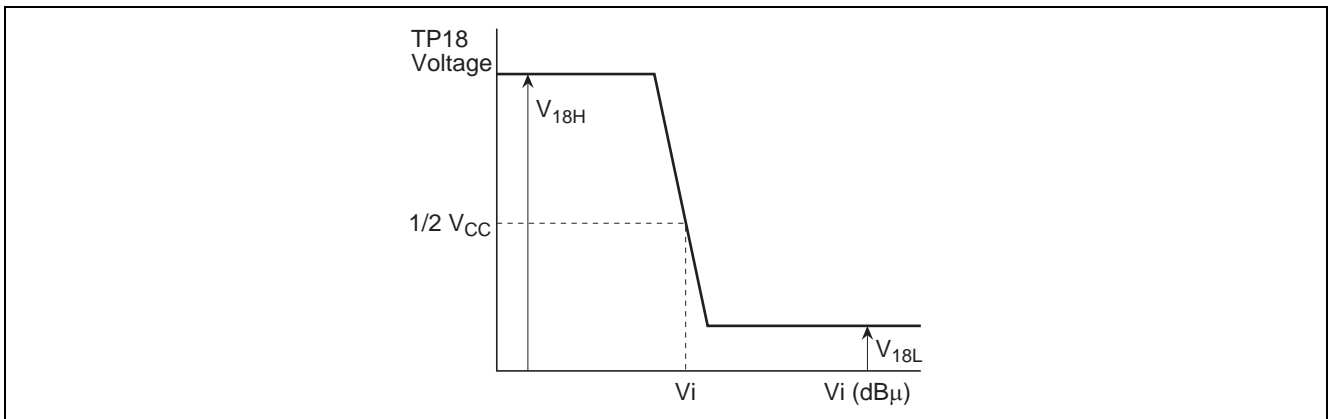

### CL-U Capture Range

1. Increase the frequency of SG9 until the VCO is out of locked-oscillation.
2. Decrease the frequency of SG9 and measure the frequency  $f_U$  when the VCO locks.

$$CL-U = f_U - 45.75 \text{ (MHz)}$$

### CL-L Capture Range

1. Decrease the frequency of SG9 until the VCO is out of locked-oscillation.
2. Increase the frequency of SG9 and measure the frequency  $f_L$  when the VCO locks.

$$CL-L = 45.75 - f_L \text{ (MHz)}$$

### CL-T Capture Range

$$CL-T = CL-U + CL-L \text{ (MHz)}$$

### $\mu$ AFT Sensitivity, $V_{19H}$ AFT Maximum Voltage, $V_{19L}$ AFT Minimum Voltage

1. Input SG10 into VIF IN, and set the frequency of SG 10 so that the voltage of AFT output TP19 is 5 V. This frequency is named  $f(3)$ .
2. Set the frequency of SG10 so that the AFT output voltage is 4 V. This frequency is named  $f(2)$ .
3. In the graph, maximum and minimum DC voltage are  $V_{19H}$  and  $V_{19L}$ , respectively.

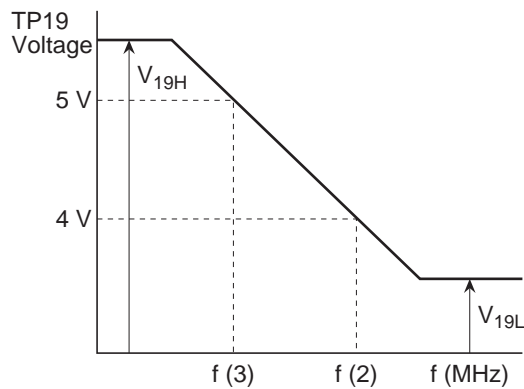

$$\mu = \frac{1000 \text{ (mV)}}{f(2) - f(3) \text{ (kHz)}} \quad (\text{mV/kHz})$$

### IM Intermodulation

1. Input SG11 into VIF IN, and measure EQ output TP3A with an oscilloscope.
2. Adjust AGC filter voltage V13 so that the minimum DC level of the output waveform is 1.0 V.
3. At this time, measure, TP3A with a spectrum analyzer. The intermodulation is defined as a difference between 0.92 MHz and 3.58 MHz frequency components.

### LIM Limiting Sensitivity

1. Input SG17 (V<sub>i</sub> = 90 dB $\mu$ ) into SIF input, and measure the 400 Hz component level of AF output TP11.
2. Lower the input level of SG17, and measure the level of SG17 when the VoAF level reaches -3 dB.

### AMR AM Rejection

1. Input SG18 into SIF input, and measure the output level of AF output TP11. This level is named VAM.
2. AMR is;

$$\text{AMR} = 20 \log \left( \frac{V_{\text{OAF}} \text{ (mVrms)}}{V_{\text{AM}} \text{ (mVrms)}} \right) \quad (\text{dB})$$

### AF S/N

1. Input SG19 into SIF input, and measure the output noise level of AF output TP11. This level is named VN.
2. S/N is;

$$\text{S/N} = 20 \log \left( \frac{V_{\text{OAF}} \text{ (mVrms)}}{V_{\text{N}} \text{ (mVrms)}} \right) \quad (\text{dB})$$

## The Note in the System Setup

M52334FP has 2 power supply pins of  $V_{CC}$  (pin 7) and  $V_{reg. OUT}$  (pin 4). Pin 7 is for AFT output, RF AGC output circuits and 5 V regulated power supply circuit and pin 4 is for the other circuit blocks. In case M52334FP is used together with other ICs like VIF operating at more than 5 V, the same supply voltage as that of connected ICs is applied to  $V_{CC}$  and  $V_{reg. OUT}$  is opened. The other circuit blocks, connected to  $V_{reg. OUT}$  are powered by internal 5 V regulated power supply.

In case the connecting ICs are operated at 5 V, 5 V is supplied to both  $V_{CC}$  and  $V_{reg. OUT}$ .

## Input Signal

SG No.	Signals (50 $\Omega$ Termination)
1	$f_0 = 45.75$ MHz AM 20 kHz 77.8% 90 dB $\mu$
2	$f_0 = 45.75$ MHz 90 dB $\mu$ CW
3	$f_1 = 45.75$ MHz 90 dB $\mu$ CW (Mixed signal) $f_2 =$ Frequency variable 70 dB $\mu$ CW (Mixed signal)
4	$f_0 = 45.75$ MHz AM 20 kHz 77.8% level variable
5	$f_0 = 45.75$ MHz AM 20 kHz 14.0% level variable
6	$f_0 = 45.75$ MHz 80 dB $\mu$ CW
7	$f_0 = 45.75$ MHz 110 dB $\mu$ CW
8	$f_0 = 45.75$ MHz CW level variable
9	$f_0 =$ Variable AM 20 kHz 77.8% 90dB $\mu$
10	$f_0 =$ Variable 90 dB $\mu$ CW
11	$f_1 = 45.75$ MHz 90 dB $\mu$ CW (Mixed signal) $f_2 = 42.17$ MHz 80 dB $\mu$ CW (Mixed signal) $f_3 = 41.25$ MHz 80 dB $\mu$ CW (Mixed signal)
12	$f_0 = 45.75$ MHz 87.5% TV modulation ten-step waveform Sync tip level 90 dB $\mu$
13	$f_1 = 41.25$ MHz 103 dB $\mu$ CW
14	$f_1 = 41.25$ MHz 70 dB $\mu$ CW
15	$f_1 = 45.75$ MHz 90 dB $\mu$ CW (Mixed signal) $f_2 = 41.25$ MHz 70 dB $\mu$ CW (Mixed signal)
16	$f_0 = 4.5$ MHz 90 dB $\mu$ FM 400 Hz $\pm$ 25 kHz dev
17	$f_0 = 4.5$ MHz FM 400 Hz $\pm$ 25 kHz dev level variable
18	$f_0 = 4.5$ MHz 90 dB $\mu$ AM 400 Hz 30%
19	$f_0 = 4.5$ MHz 90 dB $\mu$ CW



Test Circuit

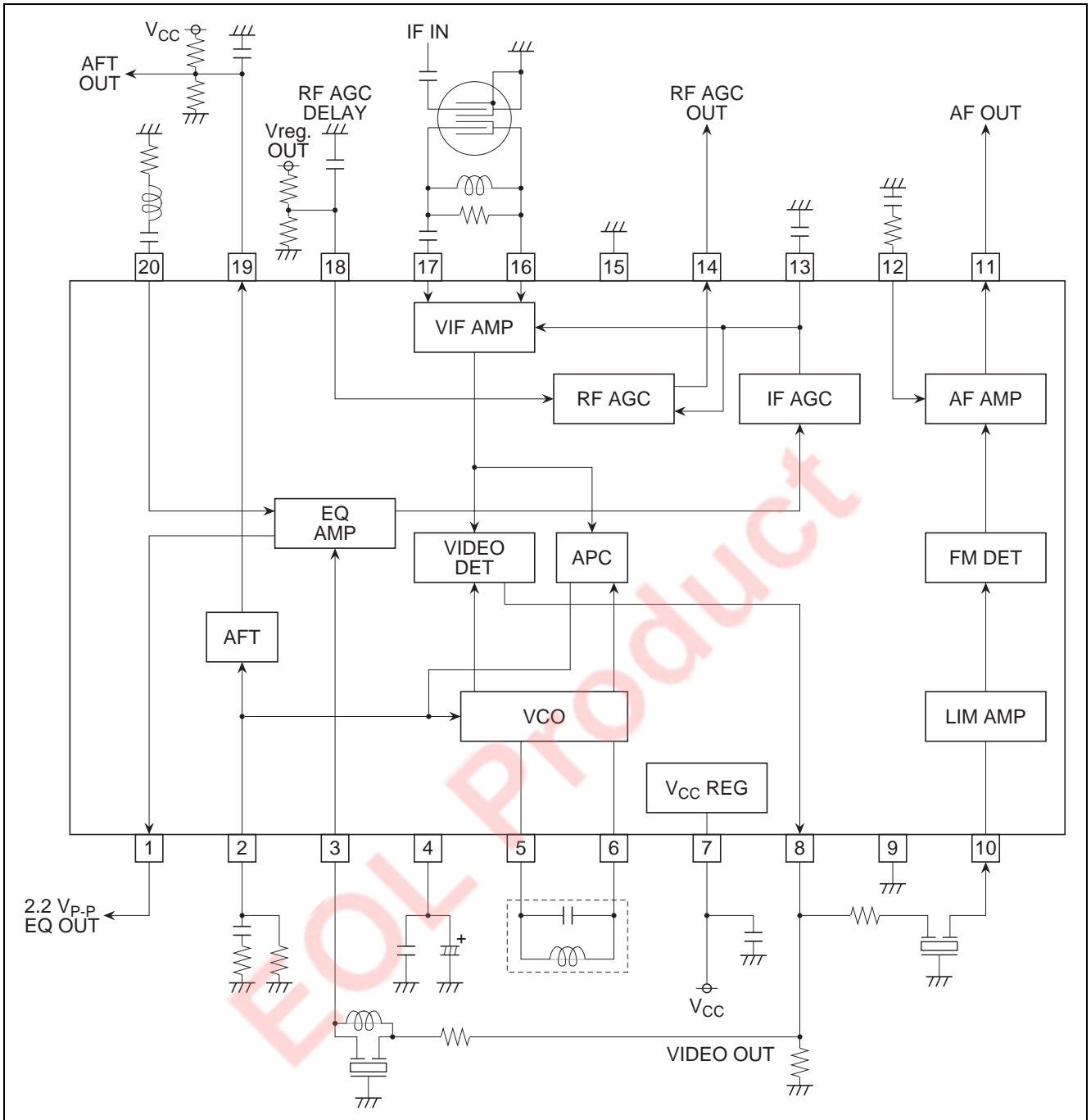

### Typical Characteristics

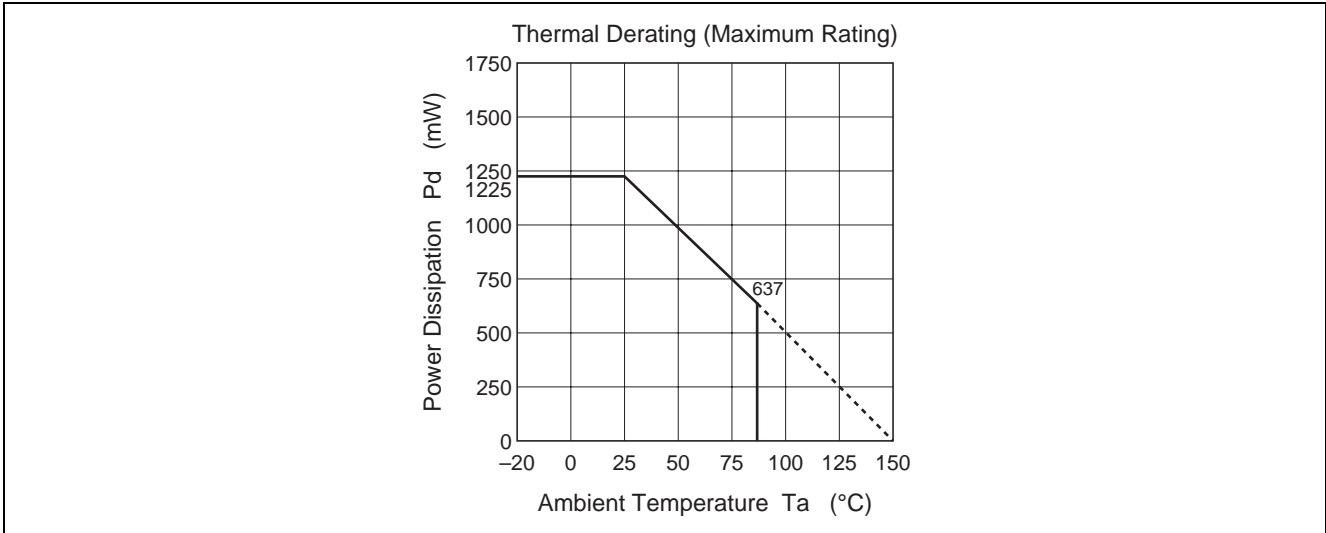

EOL Product

Application Example 1

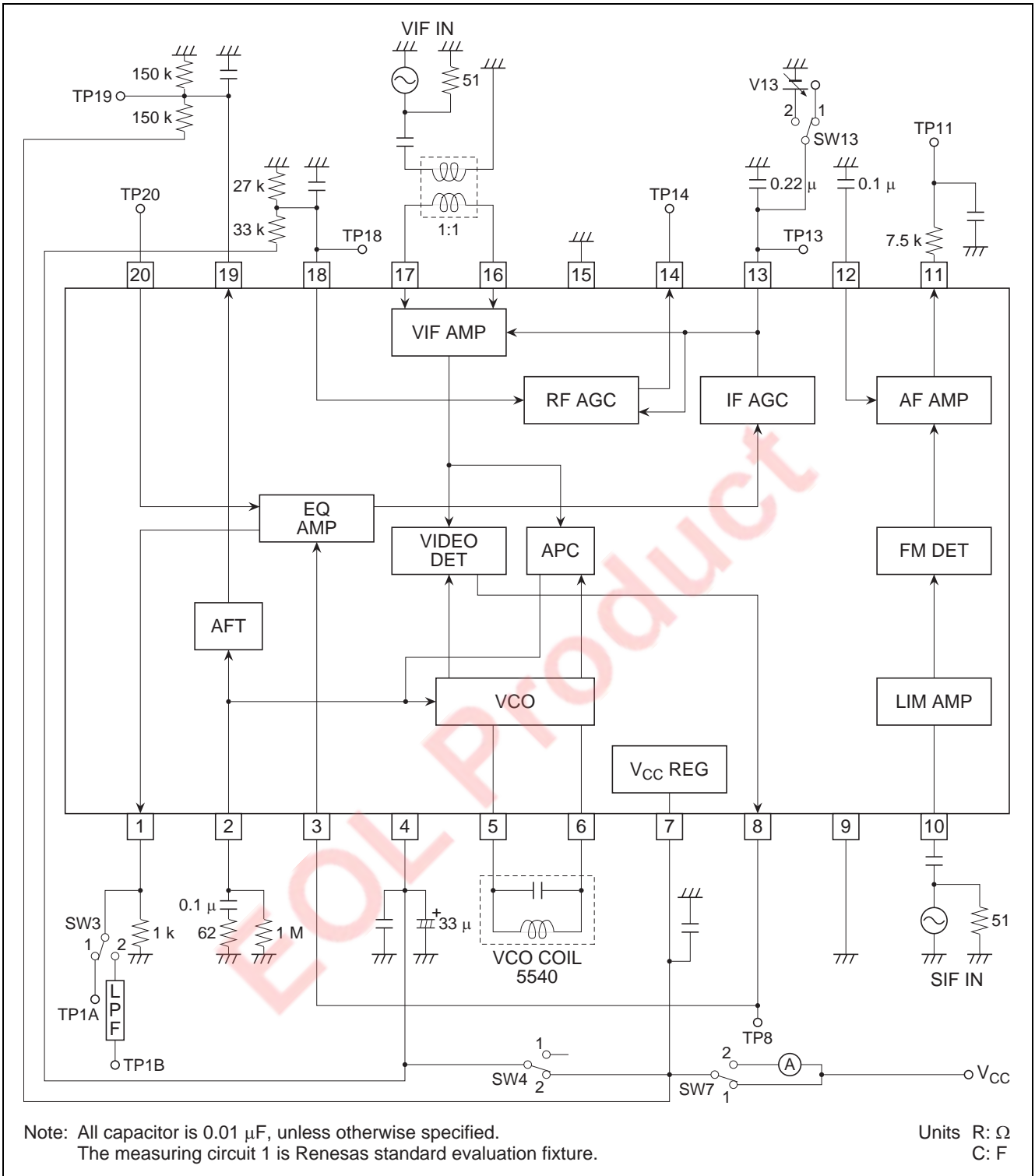

Application Example 2

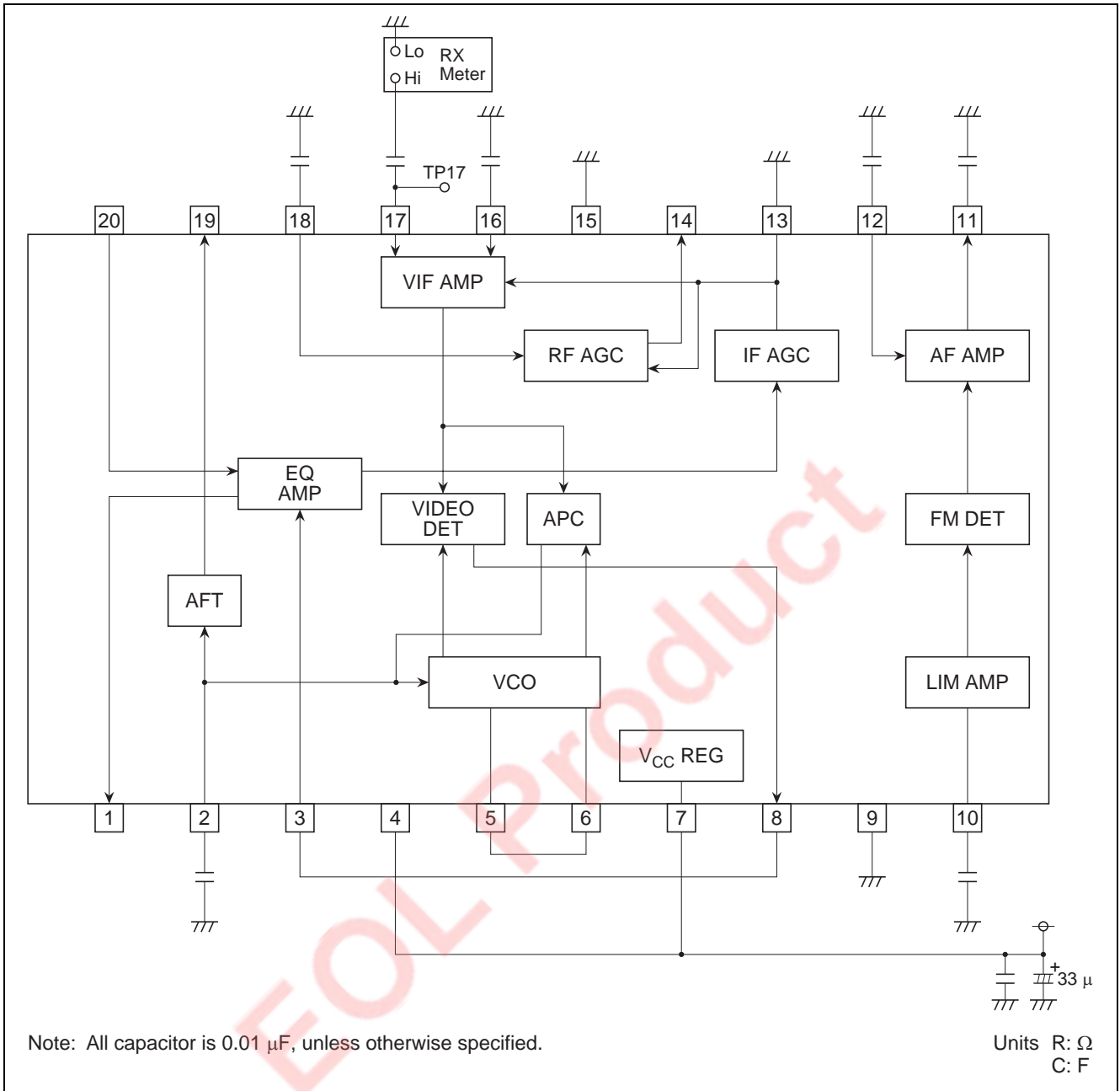

## Pin Description

### Pin 1 (EQ OUT)

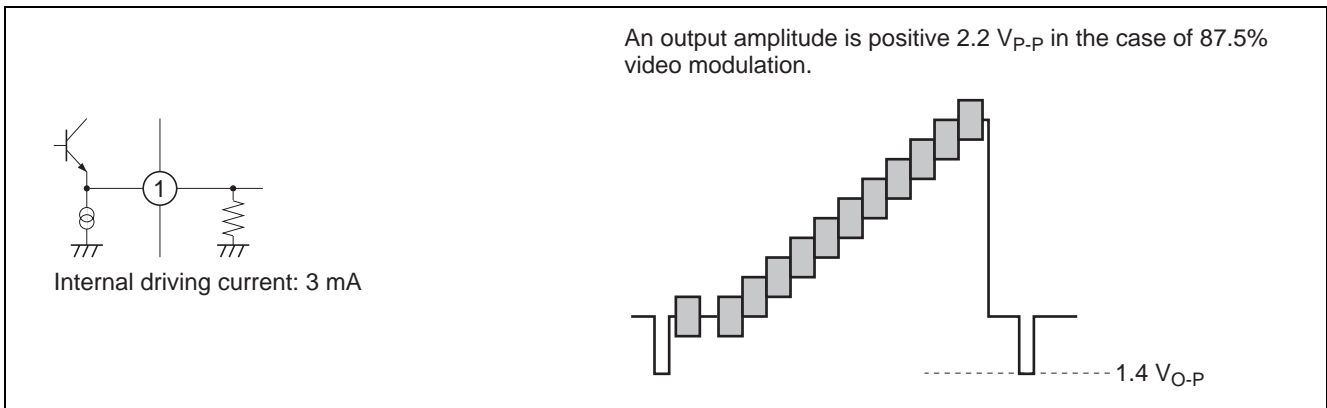

### Pin 2 (APC FILTER)

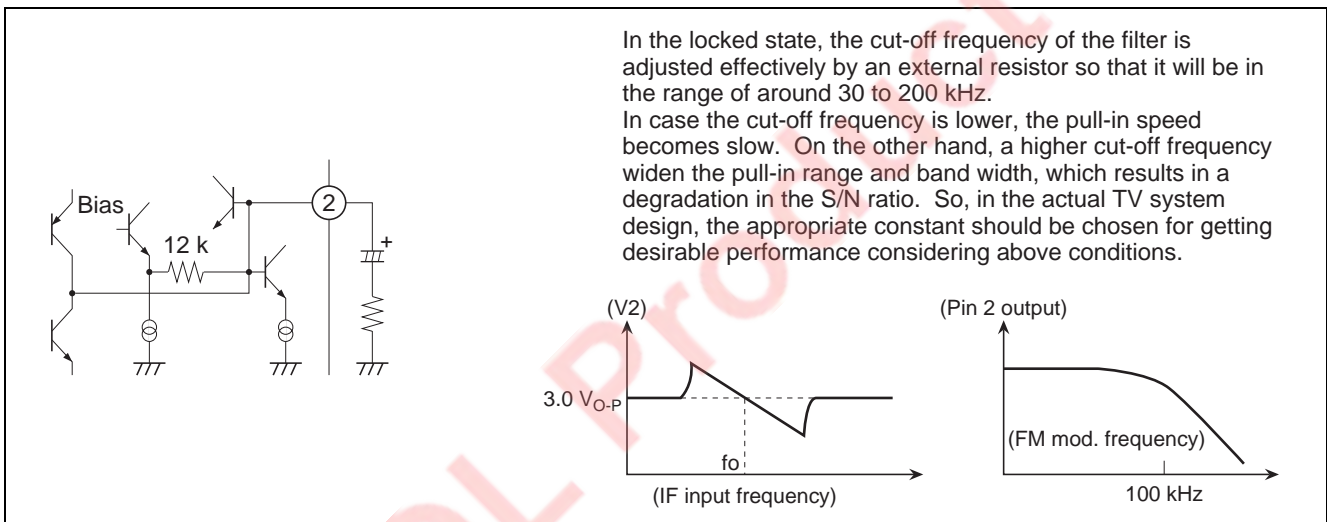

### Pin 3 (EQ IN)

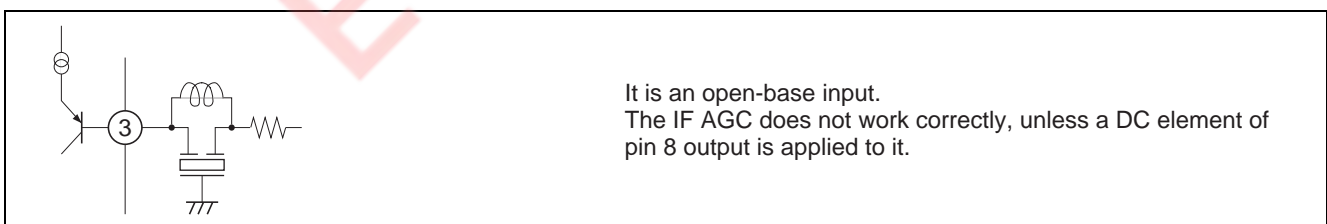

### Pin 4 (Vreg. OUT)

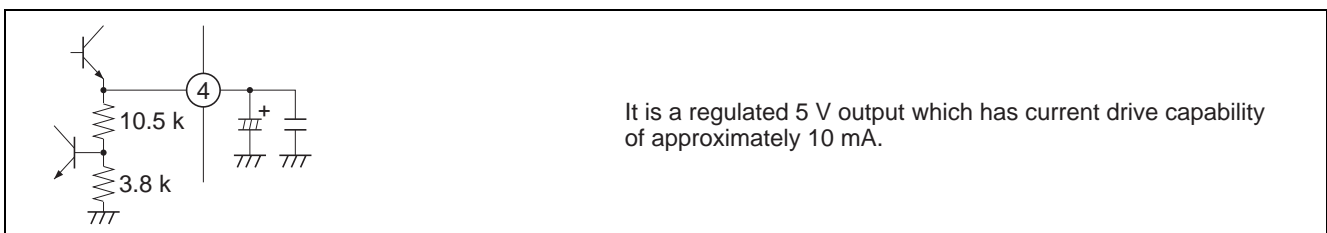

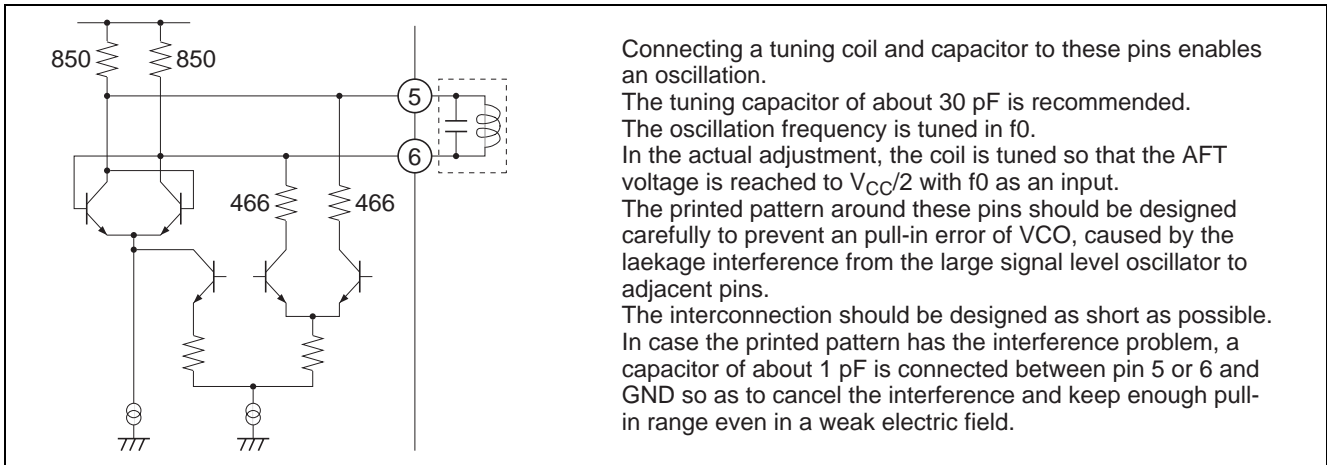
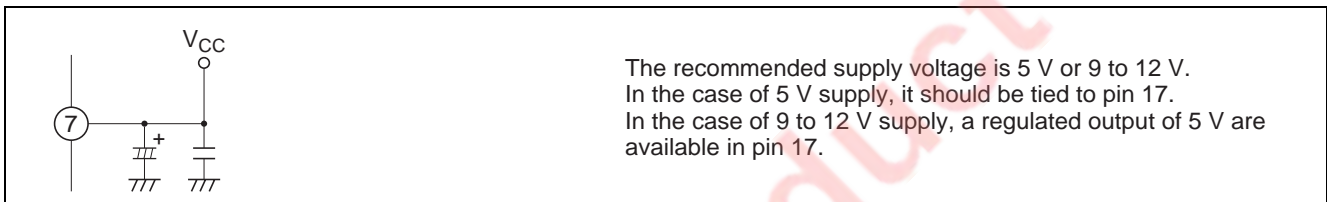
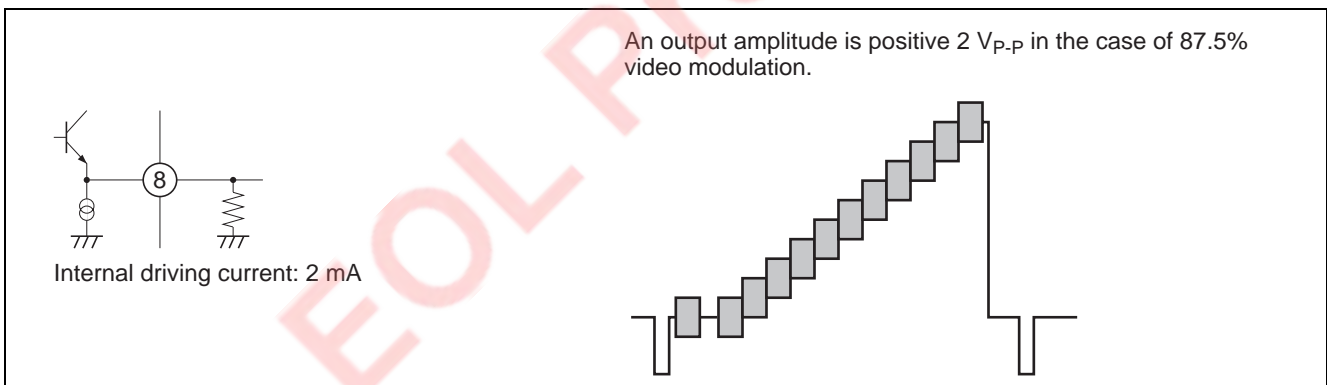
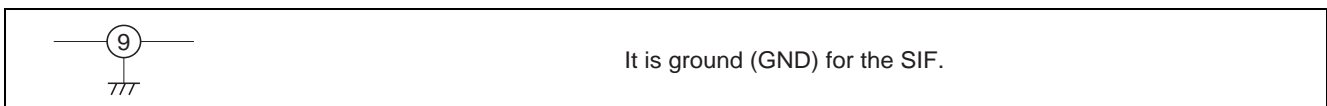
**Pin 5, Pin 6 (VCO COIL)****Pin 7 ( $V_{CC}$ )****Pin 8 (VIDEO OUT)****Pin 9 (SIF GND)**

**Pin 10 (LIMITER IN)**

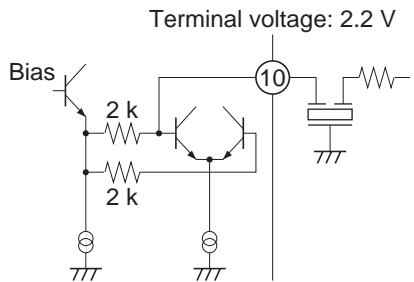

Terminal voltage: 2.2 V

The input impedance is 2 kΩ.

**Pin 11 (AUDIO OUT)**

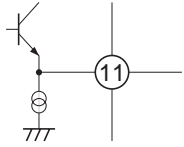

Internal driving current: 1 mA

The FM detector can respond to the 4.5 MHz intercarrier signal without an adjustment and external components by adopting the PLL technique. The output DC voltages of 4.4 V<sub>O-P</sub> and 2.4 V<sub>O-P</sub> are in the V<sub>CC</sub> of 9 V and 5 V, respectively. Since its output frequency is more than 100 kHz in no loading condition, it can also respond to the multi audio broadcasting.

**Pin 12 (NFB)**

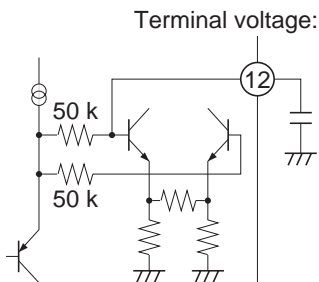

Terminal voltage: 3.0 V

The frequency response of the audio output is set by the external capacitor of pin 12.

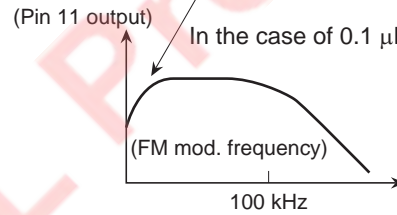

Connecting series resistor to the capacitor above, can reduce an audio output amplitude.

**Pin 13 (IF AGC FILTER)**

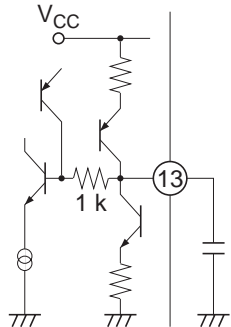

In spite of the 1-pin filter configuration, 2-pin filter characteristics are available by utilizing the dynamic AGC circuit.

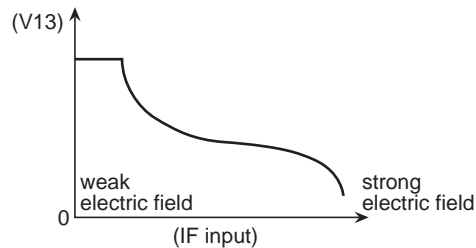

**Pin 14 (RF AGC OUT)**

The maximum outflow current is 0.2 mA.  
The maximum inflow current is 0.2 mA.

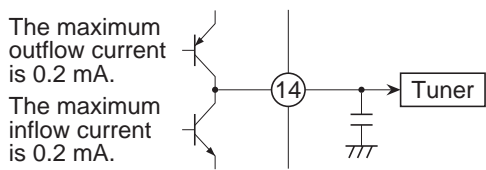

A current mode output is available in the reverse AGC operation.

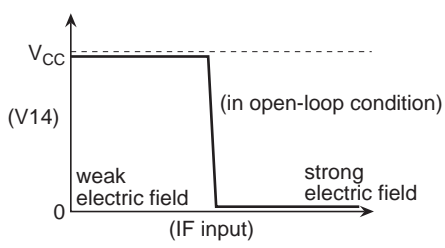

Note: Connecting a nonpolarity capacitor of 1  $\mu$ F between pin 14 and pin 18 improves AGC operating speed.  
In that case, the capacitors between pin 14/pin 18 and ground should be removed.

**Pin 15 (GND)**

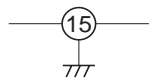

It is GND pin except for SIF.

**Pin 16, Pin 17 (VIF IN)**

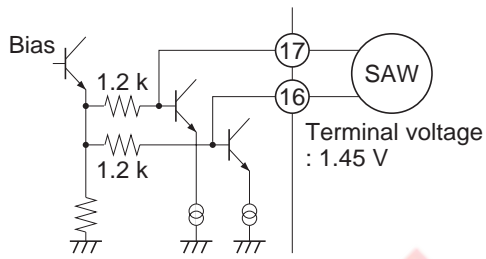

It should be designed considering careful impedance matching with the SAW filter.

**Pin 18 (RF AGC DELAY)**

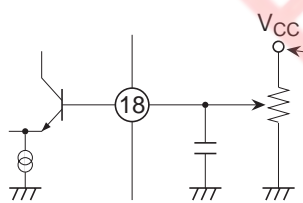

An applied voltage to the pin 18 is for changing a RF AGC delay point.

In the 3-in-1 type application, the regulated output from the regulator is suitable for a power supply ( $V_{CC}$ ) to it, because there may be difference between the tuner and main board supply.

TV tuner, VIF demodulator and RF modulator are together in one package.



**Pin 19 (AFT OUT)**

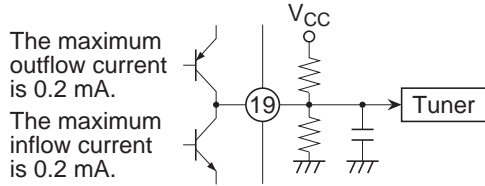

The maximum outflow current is 0.2 mA.  
The maximum inflow current is 0.2 mA.

Since an AFT output is provided by a high impedance source, the detection sensitivity can be set by an external resistor.

The muting operation will be on in following two cases;

- 1) the APC is out of locking,
- 2) the video output becomes small enough in a weak electric field.

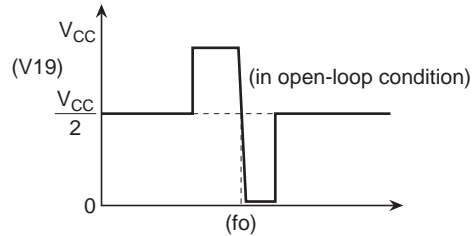

**Note:** In the case of 5 V supply, it should be considered that the maximum AFT and RF AGC output are less than 4.2 V and 4.7 V, respectively.

**Pin 20 (EQ F/B)**

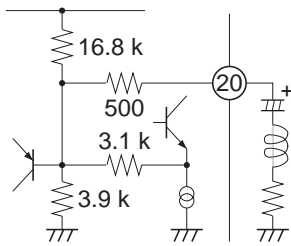

Both the external coil and capacitor determine the frequency response of EQ output.

The series connected resistor is for damping.

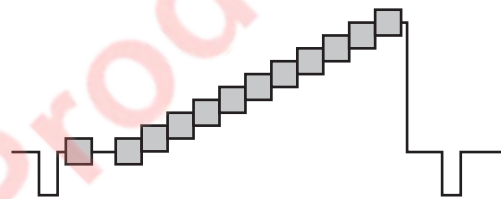

### Package Dimensions

JEITA Package Code	RENESAS Code	Previous Code	MASS[Typ.]
P-SOP20-5.3x12.6-1.27	PRSP0020DA-A	20P2N-A	0.3g

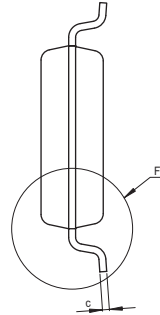
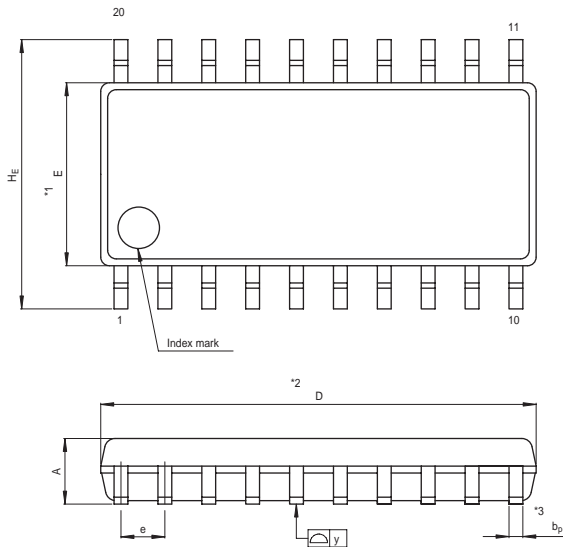

NOTE)  
 1. DIMENSIONS \*\*1\* AND \*\*2\* DO NOT INCLUDE MOLD FLASH.  
 2. DIMENSION \*\*3\* DOES NOT INCLUDE TRIM OFFSET.

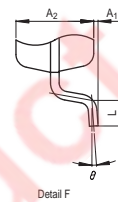

Reference Symbol	Dimension in Millimeters		
	Min	Nom	Max
D	12.5	12.6	12.7
E	5.2	5.3	5.4
A <sub>2</sub>	—	1.8	—
A <sub>1</sub>	0	0.1	0.2
A	—	—	2.1
b <sub>p</sub>	0.35	0.4	0.5
c	0.18	0.2	0.25
θ	0°	—	8°
H <sub>E</sub>	7.5	7.8	8.1
e	1.12	1.27	1.42
y	—	—	0.1
L	0.4	0.6	0.8

EOL Product

Notes:

1. This document is provided for reference purposes only so that Renesas customers may select the appropriate Renesas products for their use. Renesas neither makes warranties or representations with respect to the accuracy or completeness of the information contained in this document nor grants any license to any intellectual property rights or any other rights of Renesas or any third party with respect to the information in this document.
2. Renesas shall have no liability for damages or infringement of any intellectual property or other rights arising out of the use of any information in this document, including, but not limited to, product data, diagrams, charts, programs, algorithms, and application circuit examples.
3. You should not use the products or the technology described in this document for the purpose of military applications such as the development of weapons of mass destruction or for the purpose of any other military use. When exporting the products or technology described herein, you should follow the applicable export control laws and regulations, and procedures required by such laws and regulations.
4. All information included in this document such as product data, diagrams, charts, programs, algorithms, and application circuit examples, is current as of the date this document is issued. Such information, however, is subject to change without any prior notice. Before purchasing or using any Renesas products listed in this document, please confirm the latest product information with a Renesas sales office. Also, please pay regular and careful attention to additional and different information to be disclosed by Renesas such as that disclosed through our website. (<http://www.renesas.com>)
5. Renesas has used reasonable care in compiling the information included in this document, but Renesas assumes no liability whatsoever for any damages incurred as a result of errors or omissions in the information included in this document.
6. When using or otherwise relying on the information in this document, you should evaluate the information in light of the total system before deciding about the applicability of such information to the intended application. Renesas makes no representations, warranties or guarantees regarding the suitability of its products for any particular application and specifically disclaims any liability arising out of the application and use of the information in this document or Renesas products.
7. With the exception of products specified by Renesas as suitable for automobile applications, Renesas products are not designed, manufactured or tested for applications or otherwise in systems the failure or malfunction of which may cause a direct threat to human life or create a risk of human injury or which require especially high quality and reliability such as safety systems, or equipment or systems for transportation and traffic, healthcare, combustion control, aerospace and aeronautics, nuclear power, or undersea communication transmission. If you are considering the use of our products for such purposes, please contact a Renesas sales office beforehand. Renesas shall have no liability for damages arising out of the uses set forth above.
8. Notwithstanding the preceding paragraph, you should not use Renesas products for the purposes listed below:
  - (1) artificial life support devices or systems
  - (2) surgical implantations
  - (3) healthcare intervention (e.g., excision, administration of medication, etc.)
  - (4) any other purposes that pose a direct threat to human lifeRenesas shall have no liability for damages arising out of the uses set forth in the above and purchasers who elect to use Renesas products in any of the foregoing applications shall indemnify and hold harmless Renesas Technology Corp., its affiliated companies and their officers, directors, and employees against any and all damages arising out of such applications.
9. You should use the products described herein within the range specified by Renesas, especially with respect to the maximum rating, operating supply voltage range, movement power voltage range, heat radiation characteristics, installation and other product characteristics. Renesas shall have no liability for malfunctions or damages arising out of the use of Renesas products beyond such specified ranges.
10. Although Renesas endeavors to improve the quality and reliability of its products, IC products have specific characteristics such as the occurrence of failure at a certain rate and malfunctions under certain use conditions. Please be sure to implement safety measures to guard against the possibility of physical injury, and injury or damage caused by fire in the event of the failure of a Renesas product, such as safety design for hardware and software including but not limited to redundancy, fire control and malfunction prevention, appropriate treatment for aging degradation or any other applicable measures. Among others, since the evaluation of microcomputer software alone is very difficult, please evaluate the safety of the final products or system manufactured by you.
11. In case Renesas products listed in this document are detached from the products to which the Renesas products are attached or affixed, the risk of accident such as swallowing by infants and small children is very high. You should implement safety measures so that Renesas products may not be easily detached from your products. Renesas shall have no liability for damages arising out of such detachment.
12. This document may not be reproduced or duplicated, in any form, in whole or in part, without prior written approval from Renesas.
13. Please contact a Renesas sales office if you have any questions regarding the information contained in this document, Renesas semiconductor products, or if you have any other inquiries.



**RENESAS SALES OFFICES**

<http://www.renesas.com>

Refer to "<http://www.renesas.com/en/network>" for the latest and detailed information.

**Renesas Technology America, Inc.**  
450 Holger Way, San Jose, CA 95134-1368, U.S.A  
Tel: <1> (408) 382-7500, Fax: <1> (408) 382-7501

**Renesas Technology Europe Limited**  
Dukes Meadow, Millboard Road, Bourne End, Buckinghamshire, SL8 5FH, U.K.  
Tel: <44> (1628) 585-100, Fax: <44> (1628) 585-900

**Renesas Technology (Shanghai) Co., Ltd.**  
Unit 204, 205, AZIACenter, No.1233 Lujiazui Ring Rd, Pudong District, Shanghai, China 200120  
Tel: <86> (21) 5877-1818, Fax: <86> (21) 6887-7858/7898

**Renesas Technology Hong Kong Ltd.**  
7th Floor, North Tower, World Finance Centre, Harbour City, Canton Road, Tsimshatsui, Kowloon, Hong Kong  
Tel: <852> 2265-6688, Fax: <852> 2377-3473

**Renesas Technology Taiwan Co., Ltd.**  
10th Floor, No.99, Fushing North Road, Taipei, Taiwan  
Tel: <886> (2) 2715-2888, Fax: <886> (2) 3518-3399

**Renesas Technology Singapore Pte. Ltd.**  
1 Harbour Front Avenue, #06-10, Keppel Bay Tower, Singapore 098632  
Tel: <65> 6213-0200, Fax: <65> 6278-8001

**Renesas Technology Korea Co., Ltd.**  
Kukje Center Bldg. 18th Fl., 191, 2-ka, Hangang-ro, Yongsan-ku, Seoul 140-702, Korea  
Tel: <82> (2) 796-3115, Fax: <82> (2) 796-2145

**Renesas Technology Malaysia Sdn. Bhd**  
Unit 906, Block B, Menara Amcorp, Amcorp Trade Centre, No.18, Jln Persiaran Barat, 46050 Petaling Jaya, Selangor Darul Ehsan, Malaysia  
Tel: <603> 7955-9390, Fax: <603> 7955-9510