

**DESCRIPTION**

M52759SP is Semiconductor Integrated Circuit for uniformity of CRT Display Monitor. It generates horizontal and vertical parabola waves and is able to revise contrast of CRT Display Monitor if it is used with Video Pre. Amp. M52742SP that has uniformity circuit .

**FEATURES**

- It can control phase of horizontal wave.
- It can changes the parabola wave unbalance .
- It contains the horizontal saw wave generator and Auto Gain Control circuit , so that it is able to keep the amplitude constant if frequency change.
- It can changes the parabola wave unbalance .
- Frequency Band Width: horizontal 24 to 120kHz  
vertical 50 to 185Hz
- Input: horizontal 5Vp-p Pulse  
vertical 3.2 Vp-p V Saw

**PIN CONFIGURATION (TOP VIEW)**

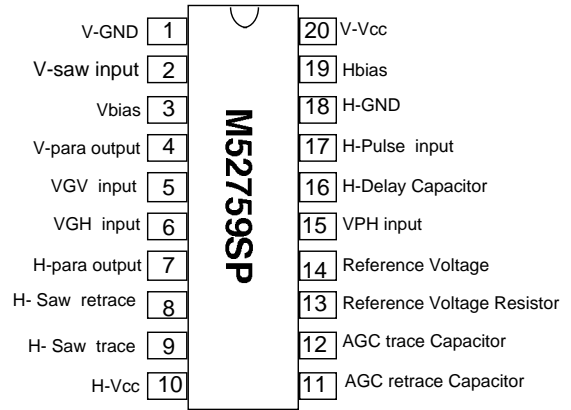

Package:20P4B

**STRUCTURE**

Bipolar Silicon Monolistic IC

**APPLICATION**

CRT Display Monitor

**Supply voltage range**

11.5V to 12.5V

**Rated supply voltage**

12V

Application Example

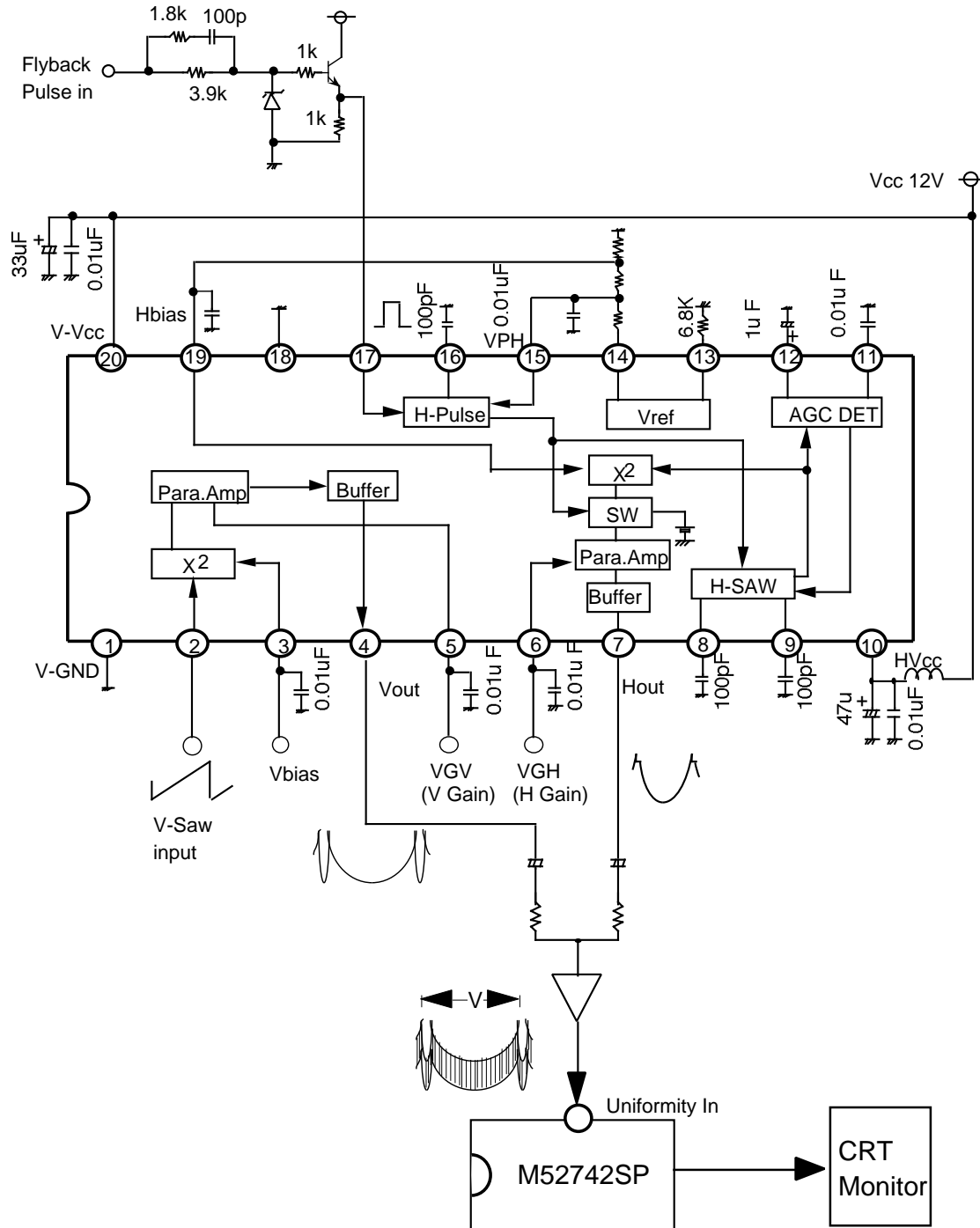
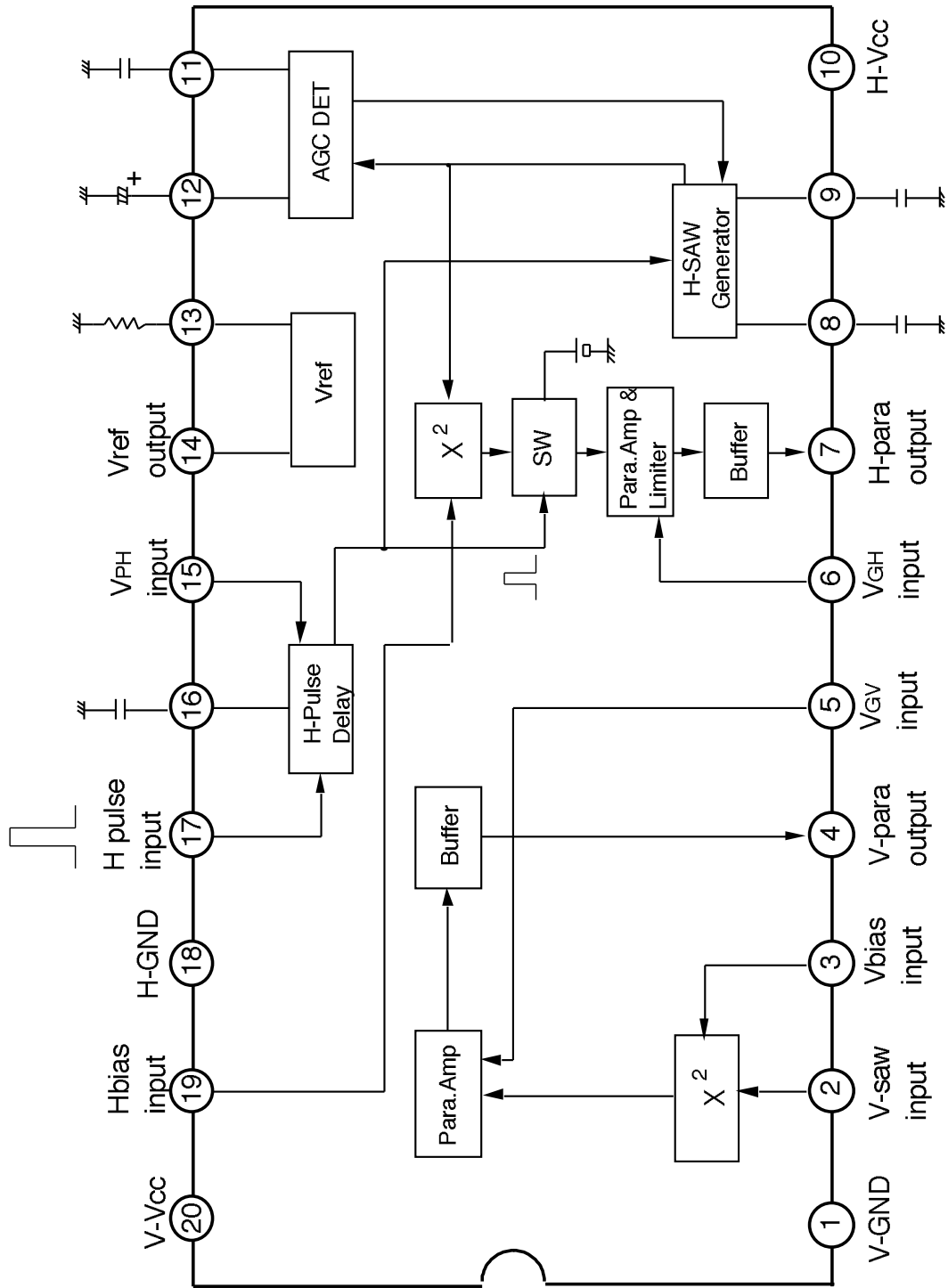
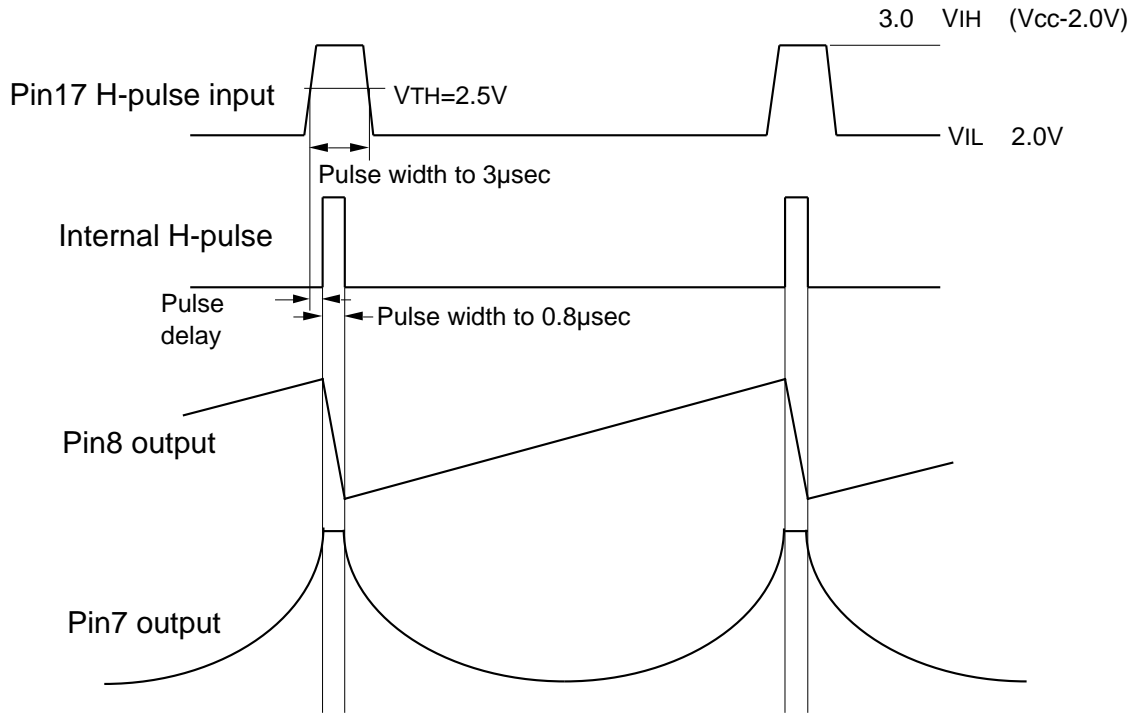

FIG1. BLOCK DIAGRAM



## FIG2. TIMING CHART

### HORIZONTAL BLOCK



### VERTICAL BLOCK

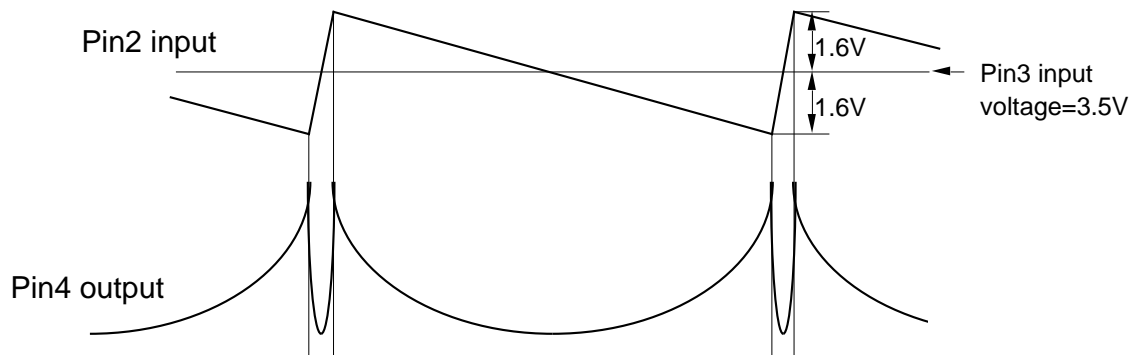

## 1.ABSOLUTE MAXIMUM RATING

(Ta = 25°C, Surge capacity=200pF)

Parameter	Symbol	Min.	Typ	Max	Unit
Supply voltage	Vcc	-	-	13.0	V
Power dissipation	Pd	-	-	1237.6	mW
Operating temperature	Topr	-20	-	+85	°C
Storage temperature	Tstg	-40	-	+150	°C
Recommended operating voltage	Vopr	-	12.0	-	V
Recommended operating voltage range	Vopr'	11.5	-	12.5	V
Surge	Vsurge	±200	-	-	V

**Fig.3 THERMAL DERATING**

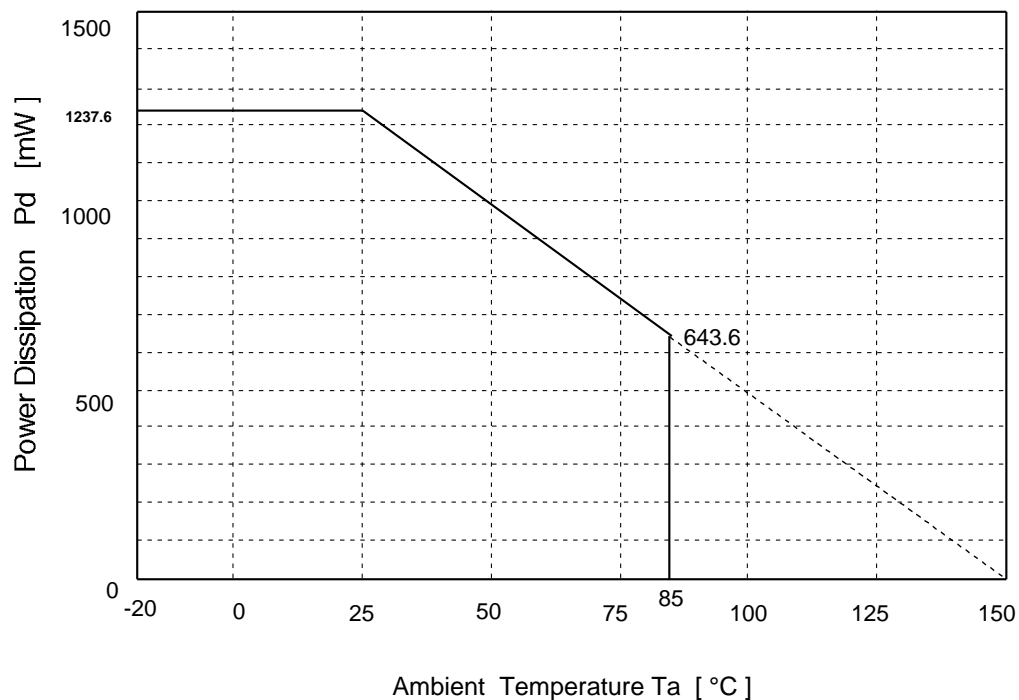

## 2.ELECTRICAL CHARACTERISTICS

(Ta=25°C, Vcc=12V, unless otherwise noted)

No	Parameter	Symbol	Test conditions	Pin	Limits			Unit
					MIN	TYP	MAX	
1	Circuit current1	Icch	⑩ Measure	⑩	15.1	21.5	27.9	mA
2	Circuit current2	Iccv	⑳ Measure	⑳	5.2	7.4	9.6	mA
3	Reference voltage output	VREF	⑭ Measure	⑭	6.75	6.95	7.15	V
4	Reference voltage temperature drift	DREF	⑭ Measure	⑭	—	49	—	ppm/deg

## HORIZONTAL BLOCK

No	Parameter	Symbol	Test conditions	Pin	Limit			Unit
					MIN	STYP	MAX	
5	H-pulse low input range	V <sub>IL</sub>	⑥2.4V in⑦Measure⑮3.0V in⑰fH=96KHz H-pulse in⑲6.1V in	⑦	0.0	—	2.0	V
6	H-pulse high input range	V <sub>IH</sub>	⑥2.4V in⑦Measure⑮3.0V in⑰fH=96KHz H-pulse in⑲6.1V in	⑦	3.0	—	VCC-2.0	V
7	H-pulse low input current	I <sub>IL</sub>	⑰0V in,measure	⑰	-5.0	-0.6	-0.1	μA
8	H-pulse high input current	I <sub>IH</sub>	⑰5V in,measure	⑰	-1.0	0.0	1.0	μA
9	H parabola width	T <sub>W</sub>	⑥2.4V in⑦Measure⑮3.0V in⑰fH=96KHz H-pulse in⑲6.1V in	⑦	0.6	0.8	1.0	μsec
10	H parabola delay 1	T <sub>D1</sub>	⑥2.4V in⑦Measure⑮0V in⑰fH=96KHz H-pulse in⑲6.1V in	⑦	0.1	0.3	0.5	μsec
11	H parabola delay 2	T <sub>D2</sub>	⑥2.4V in⑦Measure⑮1.3V in⑰fH=96KHz H-pulse in⑲6.1V in	⑦	0.4	0.6	0.8	μsec
12	H parabola delay 3	T <sub>D3</sub>	⑥2.4V in⑦Measure⑮4.0V in⑰fH=96KHz H-pulse in⑲6.1V in	⑦	2.9	3.1	3.3	μsec
13	Delay temperature drift	D <sub>D</sub>	⑥2.4V in⑦Measure⑮3.0V in⑰fH=96KHz H-pulse in⑲6.1V in	⑦	—	0.08	—	ns/deg
14	Pin⑮ input current	I <sub>⑮</sub>	⑰2.5V in,measure	⑮	-5.0	-0.3	-0.1	μA

## PROVISINAL INFORMATION

## M52759SP

## UNIFORMITY FOR CRT DISPLAY MONITOR

No	Parameter	Symbol	Test conditions	Pin	Limits			Unit
					MIN	TYP	MAX	
15	H para. unbalance control1	UHP1	⑥1.8V in⑦Measure⑮0V in⑰fH=96KHz H-pulse in⑲5.7V in	⑦	-2.6	-2.2	-1.8	V
16	H para. unbalance control2	UHP2	⑥2.4V in⑦Measure⑮0V in⑰fH=96KHz H-pulse in⑲6.1V in	⑦	0.1	0.5	0.9	V
17	H para. unbalance control3	UHP3	⑥1.8V in⑦Measure⑮0V in⑰fH=96KHz H-pulse in⑲6.4V in	⑦	1.7	2.1	2.5	V
18	H para. unbalance Vcc. character1	VUHP1	⑥2.4V in⑦Measure⑮0V in⑰fH=96KHz H-pulse in⑲6.1V in⑩⑳11.5V in	⑦	-0.2	0.0	0.2	V
19	H para. unbalance Vcc. character2	VUHP2	⑥2.4V in⑦Measure⑮0V in⑰fH=96KHz H-pulse in⑲6.1V in⑩⑳12.5V in	⑦	-0.2	0.0	0.2	V
20	H para. unbalance temperature drift	DUHP	⑥2.4V in⑦Measure⑮0V in⑰fH=96KHz H-pulse in⑲6.1V in	⑦	—	-2.2	—	mV/deg
21	H para. gain control1	GHP1	⑥1.0V in⑦Measure⑮3.0V in⑰fH=96KHz H-pulse in⑲6.1V in	⑦	0.2	0.4	0.6	Vp-p
22	H para. gain control2	GHP2	⑥2.5V in⑦Measure⑮3.0V in⑰fH=96KHz H-pulse in⑲6.1V in	⑦	2.9	3.3	3.7	Vp-p
23	H para. gain control3	GHP3	⑥4.0V in⑦Measure⑮3.0V in⑰fH=96KHz H-pulse in⑲6.1V in	⑦	5.3	6.0	6.7	Vp-p
24	H para. freq. characteristics1	FHP1	⑥4.0V in⑦Measure⑮3.0V in⑰fH=24KHz H-pulse in⑲6.1V in	⑦	-0.2	0.0	0.2	V
25	H para. freq. characteristics2	FHP2	⑥4.0V in⑦Measure⑮3.0V in⑰fH=120KHz H-pulse in⑲6.1V in	⑦	-0.2	0.0	0.2	V
26	H para. Vcc. characteristics1	VVHP1	⑥4.0V in⑦Measure⑮3.0V in⑰fH=96KHz H-pulse in⑲6.1V in⑩⑳11.5V in	⑦	-0.2	0.0	0.2	V
27	H para. Vcc. characteristics2	VVHP2	⑥4.0V in⑦Measure⑮3.0V in⑰fH=96KHz H-pulse in⑲6.1V in⑩⑳12.5V in	⑦	-0.2	0.0	0.2	V
28	H para. size temperature drift	DHP	⑥4.0V in⑦Measure⑮3.0V in⑰fH=96KHz H-pulse in⑲6.1V in	⑦	—	-1.3	—	mV/deg
29	Pin⑥ input current	I⑥	⑥2.4V in,measure	⑥	-5.0	-0.3	-0.1	μA
30	Pin⑲ input current	I⑲	⑲6.1V in,measure	⑲	0.1	0.3	5.0	μA

## PROVISINAL INFORMATION

## M52759SP

## UNIFORMITY FOR CRT DISPLAY MONITOR

## VERTICAL BLOCK

No	Parameter	Symbol	Test conditions	Pin	Limits			Unit
					MIN	TYP	MAX	
31	V parabola accuracy 1	AVP1	② 3.5V in ③ 3.5V in ④ Measure ⑤ 2.3V in	④	4.5	5.0	5.5	V
32	V parabola accuracy 2	AVP2	② 1.9V in ③ 3.5V in ④ Measure ⑤ 2.3V in	④	2.5	3.0	3.5	V
33	V parabola accuracy 3	AVP3	② 2.7V in ③ 3.5V in ④ Measure ⑤ 2.3V in	④	20	25	30	%
34	V parabola accuracy 4	AVP4	② 4.3V in ③ 3.5V in ④ Measure ⑤ 2.3V in	④	20	25	30	%
35	V parabola accuracy 5	AVP5	② 5.1V in ③ 3.5V in ④ Measure ⑤ 2.3V in	④	90	100	110	%
36	V para. unbalance control1	UVP1	② fv=70Hz, 3.2Vpp saw wave in ③ 2.8V in ④ Measure ⑤ 1.6V in	④	-2.8	-2.5	-2.2	V
37	V para. unbalance control2	UVP2	② fv=70Hz, 3.2Vpp saw wave in ③ 3.5V in ④ Measure ⑤ 2.3V in	④	-0.3	0	0.3	V
38	V para. unbalance control3	UVP3	② fv=70Hz, 3.2Vpp saw wave in ③ 4.2V in ④ Measure ⑤ 1.6V in	④	2.2	2.5	2.8	V
39	V unbalance. Vcc. characteristics 1	VUVP1	② fv=70Hz, 3.2Vpp saw wave in ③ 3.5V in ④ Measure ⑤ 2.3V in ⑩ ⑪ 11.5V in	④	-0.1	0.0	0.1	V
40	V unbalance. Vcc. characteristics 2	VUVP2	② fv=70Hz, 3.2Vpp saw wave in ③ 3.5V in ④ Measure ⑤ 2.3V in ⑩ ⑪ 12.5V in	④	-0.1	0.0	0.1	V
41	V unbalance. temperature drift	DUVP	② fv=70Hz, 3.2Vpp saw wave in ③ 3.5V in ④ Measure ⑤ 2.3V in	④	—	0.5	—	mV/deg
42	V parabola amplitude 1	GVP1	② fv=70Hz, 3.2Vpp saw wave in ③ 3.5V in ④ Measure ⑤ 1.0V in	④	0	0	0.3	Vp-p
43	V parabola amplitude 2	GVP2	② fv=70Hz, 3.2Vpp saw wave in ③ 3.5V in ④ Measure ⑤ 2.0V in	④	2.1	2.4	2.7	Vp-p
44	V parabola amplitude 3	GVP3	② fv=70Hz, 3.2Vpp saw wave in ③ 3.5V in ④ Measure ⑤ 3.0V in	④	4.2	4.7	5.2	Vp-p
45	V para. freq. characteristics 1	FVP1	② fv=50Hz, 3.2Vpp saw wave in ③ 3.5V in ④ Measure ⑤ 3.0V in	④	-0.1	0.0	0.1	V
46	V para. freq. characteristics 2	FVP2	② fv=185Hz, 3.2Vpp saw wave in ③ 3.5V in ④ Measure ⑤ 3.0V in	④	-0.1	0.0	0.1	V
47	V para. Vcc. characteristics 1	VVP1	② fv=70Hz, 3.2Vpp saw wave in ③ 3.5V in ④ Measure ⑤ 3.0V in ⑩ ⑪ 11.5V in	④	-0.1	0.0	0.1	V
48	V para. Vcc. characteristics 2	VVP2	② fv=70Hz, 3.2Vpp saw wave in ③ 3.5V in ④ Measure ⑤ 3.0V in ⑩ ⑪ 12.5V in	④	-0.1	0.0	0.1	V
49	V para. temperature drift	DVP	② fv=70Hz, 3.2Vpp saw wave in ③ 3.5V in ④ Measure ⑤ 3.0V in	④	—	-2.2	—	mV/deg
50	Pin② input current	I②	② 3.5V in,measure	②	-5.0	-0.3	-0.1	μA
51	Pin③ input current	I③	③ 3.5V in,measure	③	-5.0	-0.3	-0.1	μA
52	Pin⑤ input current	I⑤	⑤ 2.3V in,measure	⑤	-5.0	-0.3	-0.1	μA



Switch and Voltage Condition

No	Symbol	Switch									Voltage [ V ]							
		SW2	SW3	SW5	SW6	SW10	SW15	SW17	SW19	SW20	V <sub>CC</sub>	V <sub>2</sub>	V <sub>3</sub>	V <sub>5</sub>	V <sub>6</sub>	V <sub>15</sub>	V <sub>17</sub>	V <sub>19</sub>
1	ICCH	a	a	a	a	b	a	b	a	a	12.0	3.5	3.5	2.5	2.4	3.0	0	6.1
2	ICCV					a				b								
3	VREF									a								
4	DREF							▼									▼	
5	V <sub>IL</sub>							a										-
6	V <sub>IH</sub>							▼										▼
7	I <sub>IL</sub>							b										0
8	I <sub>IH</sub>							▼										5.0
9	T <sub>W</sub>							a								▼		-
10	T <sub>D1</sub>															0		
11	T <sub>D2</sub>															1.3		
12	T <sub>D3</sub>															4.0		
13	DD							▼	▼							3.0	▼	
14	I <sub>⑮</sub>							b	b					▼		-	0	▼
15	UHP1							a	a						1.8	0	-	5.7
16	UHP2														2.4			6.1
17	UHP3										▼				1.8			6.4
18	VUHP1										11.5				2.4			6.1
19	VUHP2										12.5							
20	DUHP										12.0			▼	▼			
21	GHP1														1.0	3.0		
22	GHP2														2.5			
23	GHP3														4.0			
24	FHP1																	
25	FHP2										▼							
26	VVHP1										11.5							
27	VVHP2										12.5							
28	DHP				▼			▼			12.0			▼			▼	
29	I <sub>⑯</sub>				b			b	▼							-	0	▼
30	I <sub>⑰</sub>	▼	▼	▼	a	▼	▼	▼	b	▼	▼	▼	▼	▼	2.4	▼	▼	-

PROVISINAL INFORMATION

M52759SP

UNIFORMITY FOR CRT DISPLAY MONITOR

No	Symbol	Switch									Voltage [ V ]							
		SW2	SW3	SW5	SW6	SW10	SW15	SW17	SW19	SW20	Vcc	V2	V3	V5	V6	V15	V17	V19
31	AVP1	a	a	a	a	a	a	b	a	a	12.0	3.5	3.5	2.3	2.4	3.0	0	6.1
32	AVP2											1.9						
33	AVP3											2.7						
34	AVP4											4.3						
35	AVP5	▼										5.1	▼	▼				
36	UVP1	b										-	2.8	1.6				
37	UVP2												3.5	2.3				
38	UVP3										▼		4.2	1.6				
39	VUVP1										11.5		3.5	2.3				
40	VUVP2										12.5							
41	DUVP										12.0			▼				
42	GVP1													1.0				
43	GVP2													2.0				
44	GVP3													3.0				
45	FVP1																	
46	FVP2										▼							
47	VVP1										11.5							
48	VVP1										12.5							
49	DVP	▼									12.0	▼		▼				
50	I②	c	▼									3.5		2.3				
51	I③	a	b	▼										▼				
52	I⑤	▼	a	b	▼	▼	▼	▼	▼	▼	▼	▼	▼	-	▼	▼	▼	▼

### Input Signal

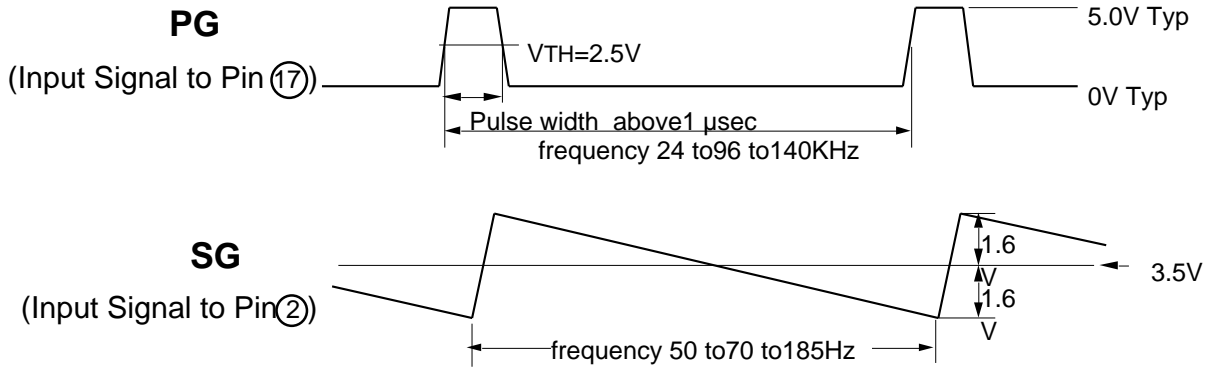

### The way to measure

- No1. ICCH Measure the input current to Pin-10.
- No2. ICCV Measure the input current to Pin-20.
- No3. VREF Measure the output voltage at Pin-14
- No4. VREF Measure temperature drift of Pin-14 .(-20°C to 85°C )

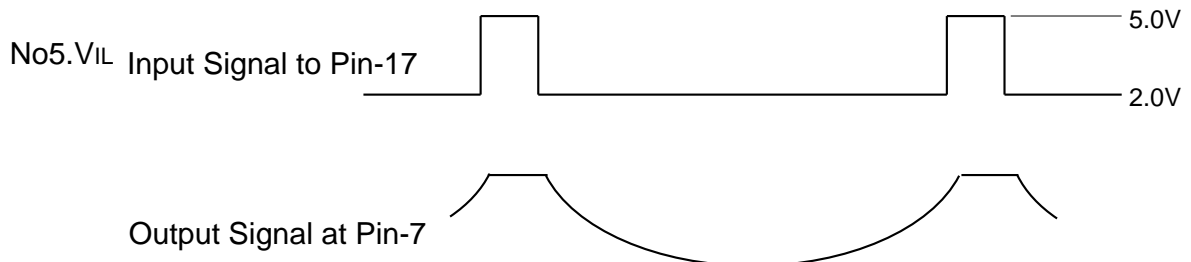

Input horizontal pulse which low level is 2V in Pin-17 and confirm output horizontal signal at Pin-7.

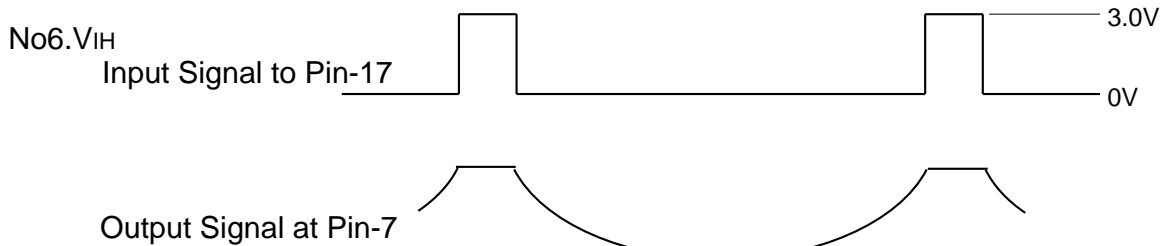

Input horizontal pulse which high level is 3V in Pin-17 and confirm output horizontal signal at Pin-7.

PROVISINAL INFORMATION

M52759SP

UNIFORMITY FOR CRT DISPLAY MONITOR

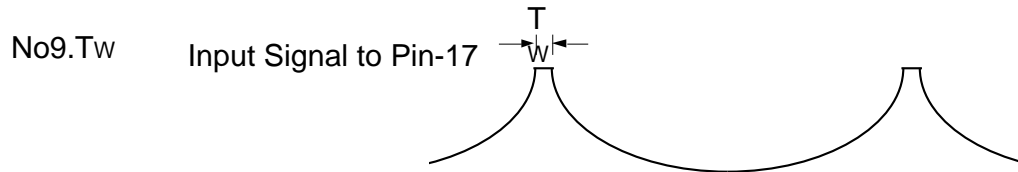

Measure the time width of retrace period at Pin-7.

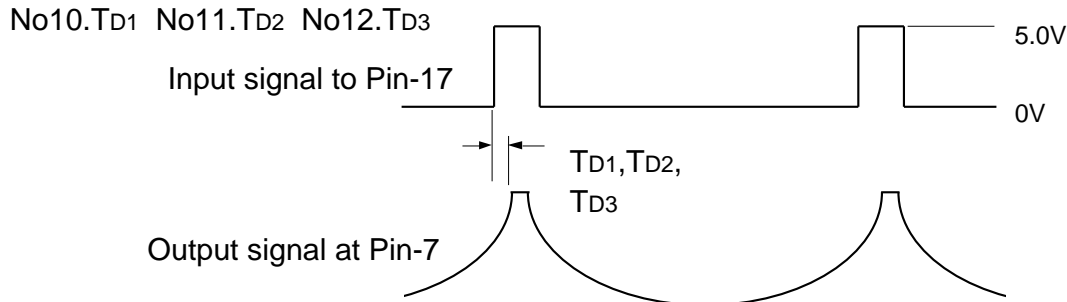

Measure the delay time from rise time of input signal to start of retrace period of output signal when the voltage of Pin-15 is 0V, 1.3V, and 4V.

NO13.D D Measure the temperature drift of the delay time.(-20°C to 85°C )

NO14.I-15 Measure the input current to Pin-15 when the voltage of Pin-15 is 2.5V.

No15.UHP1 No16.UHP2 No17.UHP3

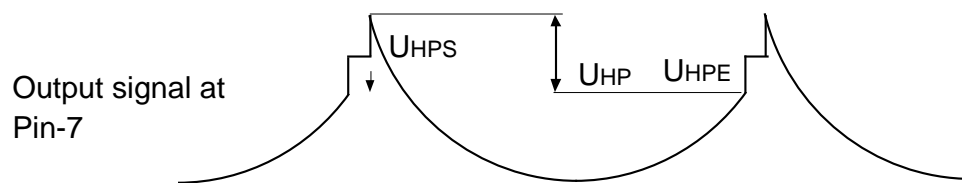

UHPS is defined as the voltage of parabola start point . UHPE is defined as the voltage of parabola end point .UHP1 UHP2 UHP3 is defined as follows

$$UHP1 \quad UHP2 \quad UHP3 = UHPS - UHPE$$

Measure the unbalance of parabola waveform at Pin-4 when the voltage of Pin-19 is 5.7V, 6.1V, and 6.4V. Pin-6 is controled so that the amplitude of parabola is 3Vp-p constant.

## PROVISINAL INFORMATION

## M52759SP

## UNIFORMITY FOR CRT DISPLAY MONITOR

- No18.V<sub>UHP1</sub> When the supply voltage of Pin-10,20 is 11.5V,the unbalance of parabola waveform at Pin-7 is defined as U<sub>HP11.5V</sub>.
- $$V_{UHP1} = U_{HP2} - U_{HP11.5V}$$
- No19.V<sub>UHP2</sub> When the supply voltage of Pin-10,20 is 12.5V,the unbalance of parabola waveform at Pin-7 is defined as U<sub>HP12.5V</sub>.
- $$V_{UHP2} = U_{HP2} - U_{HP12.5V}$$
- No20.D<sub>UHP</sub> Measure temperature drift of U<sub>HP2</sub> . ( -20°C to 85°C )
- No21.G<sub>HP1</sub> Measure the amplitude of parabola waveform at Pin-7 and it is defined as HP<sub>-6,1.0V</sub>
- No22.G<sub>HP2</sub> The amplitude of parabola waveform at Pin-7 is defined as HP<sub>-6,2.5V</sub>.
- No23.G<sub>HP2</sub> The amplitude of parabola waveform at Pin-7 is defined as HP<sub>-6,4.0V</sub>.
- NO24.F<sub>HP1</sub> When the frequency of input signal in Pin-17 is 96kHz ,the amplitude of parabola waveform at Pin-7 is defined as HP<sub>96KHZ</sub>. When the frequency of input signal is 24kHz ,the amplitude of parabola waveform is defined as HP<sub>24KHZ</sub>.
- $$F_{HP1} = HP_{96KHZ} - HP_{24KHZ}$$
- NO25.F<sub>HP2</sub> When the frequency of input signal in Pin-17 is 140kHz ,the amplitude of parabola waveform at Pin-7 is defined as HP<sub>120KHZ</sub>.
- $$F_{HP2} = HP_{96KHZ} - HP_{140KHZ}$$
- NO26.V<sub>VHP1</sub> When the supply voltage of Pin-10,20 is 12.0V,the amplitude of parabola waveform at Pin-7 is defined as HP<sub>12.0V</sub>. When the supply voltage is 11.5V,the amplitude of parabola waveform is defined as HP<sub>11.5V</sub>.
- $$V_{VHP1} = HP_{12.0V} - HP_{11.5V}$$
- NO27.V<sub>VHP2</sub> When the supply voltage of Pin-10,20 is 12.5V,the amplitude of parabola waveform at Pin-7 is defined as HP<sub>12.5V</sub>.
- $$V_{VHP2} = HP_{12.0V} - HP_{12.5V}$$
- No28.D<sub>HP</sub> Measure the temperature drift of HP<sub>96KHz</sub>. (-20°C to 85°C )
- No29.I-6 Measure the input current to Pin-6 when voltage of Pin-6 is 2.4V.
- No30.I-19 Measure the input current to Pin-19 when voltage of Pin-19 is 6.1V.

PROVISINAL INFORMATION

M52759SP

UNIFORMITY FOR CRT DISPLAY MONITOR

No31.AVP1 Measure the output voltage at Pin-4 and it is defined as VP-2,3.5V.

No32.AVP2 The output voltage at Pin-4 is defined as VP-2,1.9V.

$$AVP2 = VP-2,1.9V - VP-2,3.5V$$

No33.AVP3 The output voltage at Pin-4 is defined as VP-2,2.7V.

$$AVP3 = \frac{VP-2,2.7V - VP-2,3.5V}{VP-2,1.9V - VP-2,3.5V} \times 100 (\%)$$

No34.AVP4 The output voltage at Pin-4 is defined as VP-2,4.3V.

$$AVP4 = \frac{VP-2,4.3V - VP-2,3.5V}{VP-2,1.9V - VP-2,3.5V} \times 100 (\%)$$

No35.AVP5 The output voltage at Pin-4 is defined as VP-2,5.1V.

$$AVP5 = \frac{VP-2,5.1V - VP-2,3.5V}{VP-2,1.9V - VP-2,3.5V} \times 100 (\%)$$

No36.UVP1 No37.UVP2 No38.UVP3

Output signal at Pin-7

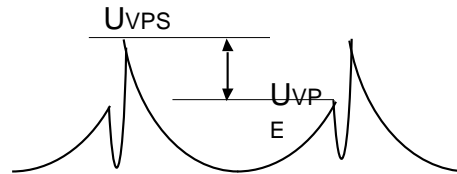

U<sub>VPS</sub> is defined as the voltage of parabola start point . U<sub>VPE</sub> is defined as the voltage of parabola end point .U<sub>VP1</sub> U<sub>VP2</sub> U<sub>VP3</sub> is defined as follows

$$U_{VP1} \ U_{VP2} \ U_{VP3} = U_{VPS} - U_{VPE}$$

Measure the unbalance of parabola waveform at Pin-4 when the voltage of Pin-3 is 2.8V,3.5V,and 4.2V. Pin-5 is controled so that the amplitude of parabola is 3Vp-p constant

No39.VVP1 When the supply voltage of Pin-10,20 is 11.5V,the unbalance of parabola waveform at Pin-4 is defined as UVP11.5V.

$$V_{UHP1} = U_{VP2} - U_{VP11.5V}$$

No40.VVP2 When the supply voltage of Pin-10,20 is 12.5V,the unbalance of parabola waveform at Pin-4 is defined as UVP12.5V.

$$V_{UVP2} = U_{VP2} - U_{VP12.5V}$$

No41.DVP Measure temperature drift of UVP2 .(-20°C to 85°C )

## PROVISINAL INFORMATION

## M52759SP

## UNIFORMITY FOR CRT DISPLAY MONITOR

No42.G<sub>VP1</sub> No43.G<sub>VP2</sub>

No44.G<sub>VP3</sub> Measure the amplitude of parabola waveform at Pin-4 when the voltage of Pin-5 is 1V,2V,and 3V.

No45.F<sub>VP1</sub> When the frequency of input signal in Pin-2 is 70Hz ,the amplitude of parabola waveform at Pin-4is defined as VP<sub>70Hz</sub>. When the frequency of input signal is 50Hz ,the amplitude of parabola waveform is defined as VP<sub>50Hz</sub>.

$$F_{VP1} = VP_{70Hz} - VP_{50Hz}$$

No46.F<sub>VP2</sub> When the frequency of input signal in Pin-2 is185Hz ,the amplitude of parabola waveform at Pin-4 is defined as VP<sub>185Hz</sub>.

$$F_{VP2} = VP_{70Hz} - VP_{185Hz}$$

No47.V<sub>VP1</sub> When the voltage of Pin-10,20 is 12.0V,the amplitude of parabola waveform is defined as VP<sub>12.0V</sub>. When the voltage is 11.5V,the amplitude of parabola waveform is defined as VP<sub>11.5V</sub>.

$$V_{VP1} = VP_{12.0V} - VP_{11.5V}$$

No48.V<sub>VP2</sub> When the voltage of Pin-10,20 is 12.5V,the amplitude of parabola waveform is defined as VP<sub>12.5V</sub>.

$$V_{VP2} = VP_{12.0V} - VP_{12.5V}$$

No49.Du<sub>VP</sub> Measure temperature drift of VP<sub>70Hz</sub>. (-20°C to 85°C)

No50.I-2 Measure the input current to Pin-2 when the voltage of Pin-2 is 3.5V.

No51.I-3 Measure the input current to Pin-3when the voltage of Pin-3 is 3.5V.

No52.I-5 Measure the input current to Pin-5when the voltage of Pin-5 is 2.4V.





### 3.TYPICAL CHARACTERISTICS

Note: This is not final characteristics.

#### Horizontal Block

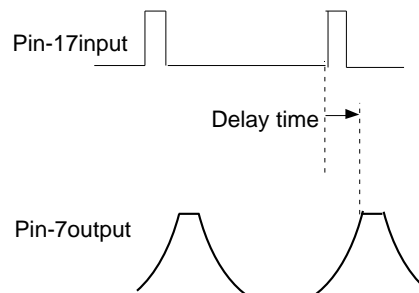
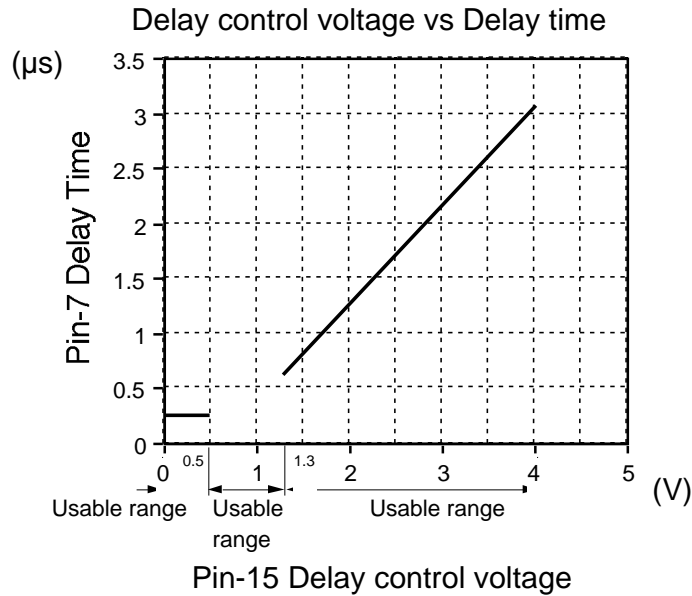

#### H unbarance control bias voltage vs H parabola unbarance

Pin-6 is controlled as the amplitude of parabola is 3Vp-p constant

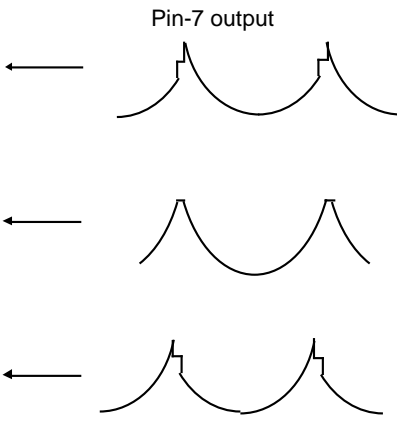
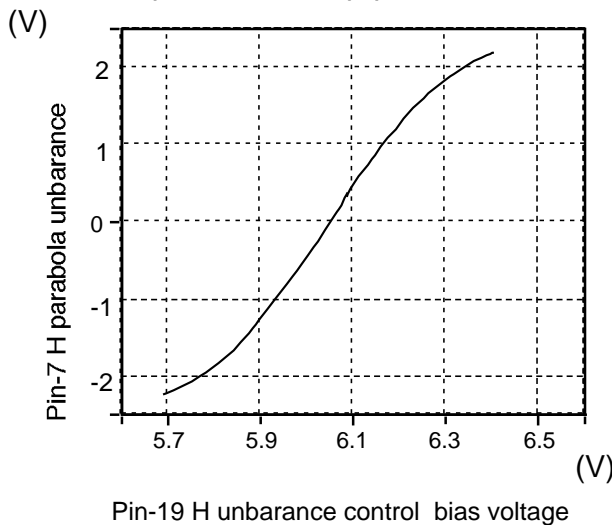

H gain control voltage vs H parabola amplitude

(Vp-p)

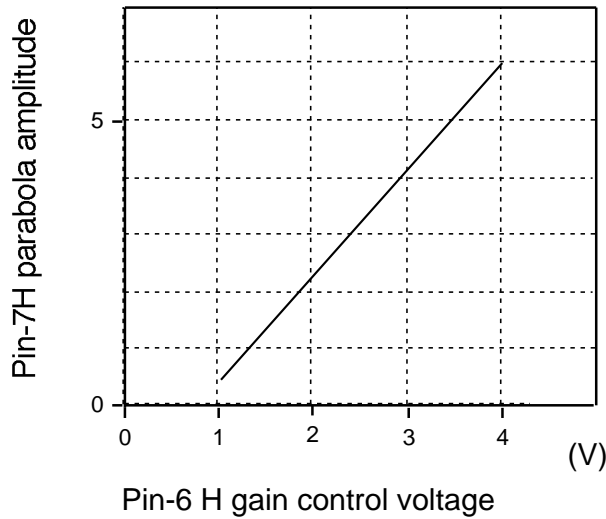

Pin-19 = 6.1V  
const.

Vertical Block

V para DC output voltage ratio

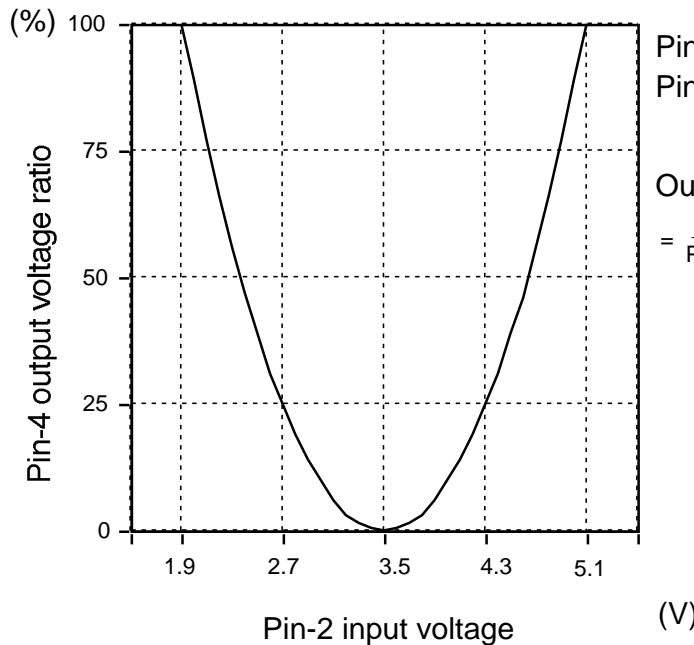

Pin-3=3.5V const.  
Pin-5=2.3V const.

Output ratio

$$= \frac{\text{Pin-4out} - \text{Pin-4out@Pin-4=3.5V}}{\text{Pin-4out@Pin-2=1.9V} - \text{Pin-4out@Pin-2=3.5V}} \times 100 (\%)$$

V unbarance control bias voltage vs V parabola unbarance

Pin-5 is controled as the amplitude of parabola is 3Vp-p constant

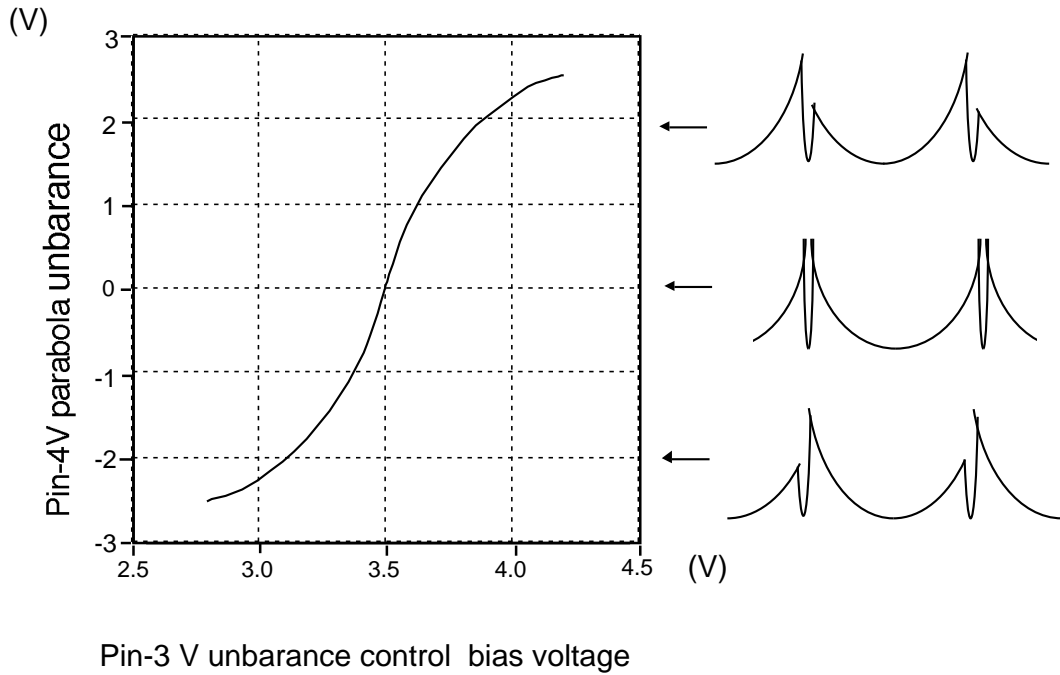

V para amp gain control voltage vs output amplitude

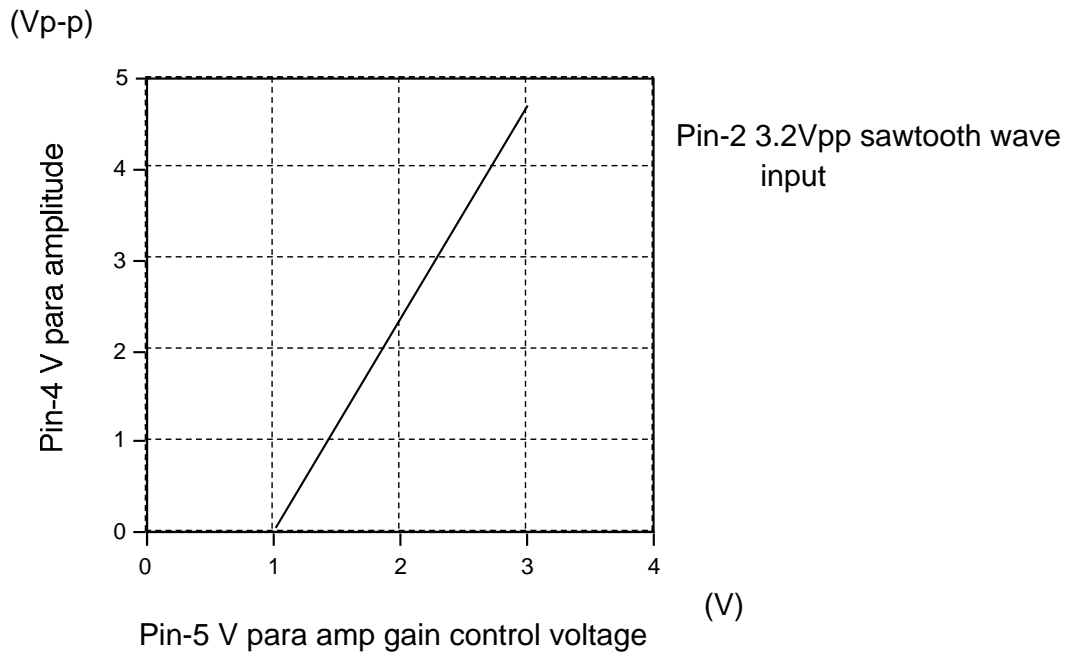



### 4.DESCRPTION OF PIN

Pin NO	Name	DC Voltage	Equivalent circuit of pin	Remarks
1	V-GND			GND of vertical block
2	Vsawi	3.5V		Vertical sawtooth wave input pin. 
3	Vbias	2.8 to 4.2V		Vertical parabola unbarance control bias voltage input pin. Input voltage range is 2.8 to 4.2V
4	Vout	5V (Bottom)		Vertical parabola wave output pin.  Bottom voltage=5V(fixed) Amplitude is possible to control by pin-5
5	Vgv	1.0 to 3.0V		Vertical parabola wave gain control voltage input pin. Input voltage range is 1.0 to 3.0V.
6	VGH	1.0 to 4.0V		Horizontal parabola wave gain control voltage input pin. Input voltage range is 1.0 to 4.0V.

Pin NO	Name	DC Voltage	Equivalent circuit of pin	Remarks
7	Hout	2.4 to 9.2V		<p>horizontal parabola wave output pin.</p> <p>Amplitude is possible to control by pin-6.</p>
8	Cret	7.1V (Top) 4.9V (Bottom)		<p>Connection pin of horizontal retrace capacitor. Recommended capacitance is 100pF.</p>
9	Ctrc	7.1V (Top) 4.9V (Bottom)		<p>Connection pin of horizontal trace capacitor. Recommended capacitance is 100pF.</p>
10	H-Vcc	12.0V		Vcc of horizontal block.
11	CAGCr	2.5V		<p>Connection pin of horizontal sawtooth wave AGC retrace capacitor. Recommended capacitance is 0.01μF</p>

Pin NO	Name	DC Voltage	Equivalent circuit of pin	Remarks
12	CAGC	4.0V		<p>Connection pin of horizontal AGC capacitor. Recommended capacitance is 1<math>\mu</math>F.</p>
13	Vrefr	1.28V		<p>Connection pin of reference current source resistor. Recommended resistance is 6.8K .</p>
14	Vrefo	7.0V		<p>Reference voltage output for horizontal pulse delay circuit. Should be connect more than 10k external resistor.</p>
15	VPH	0 to 0.5V 1.34. to V		<p>Delay adjustment voltage input pin of horizontal pulse. Input voltage range is 1.3 to 4.0V. At 0 to 0.5V, delay is minimized. (0.5 to 1.3V is unusable range.)</p>
16	Chpd	0V (Bottom)		<p>Connection pin of horizontal pulse delay timing capacitor. Recommended capacitance is 100pF.</p>

PROVISINAL INFORMATION

M52759SP

UNIFORMITY FOR CRT DISPLAY MONITOR

Pin NO	Name	DC Voltage	Equivalent circuit of pin	Remarks
17	HPin			Horizontal pulse input pin. Low input level is less than 2.0V, and high is 3.0 to 10V (at Vcc=12V).
18	H-GND			GND of horizontal block
19	Hbias	5.7 to 6.4V		Horizontal parabolall unbarance control bias voltage input pin. Input Voltage range is 5.7 to 6.4V.
20	V-Vcc	12.0V		Vcc of vertical block



## 5. MARK

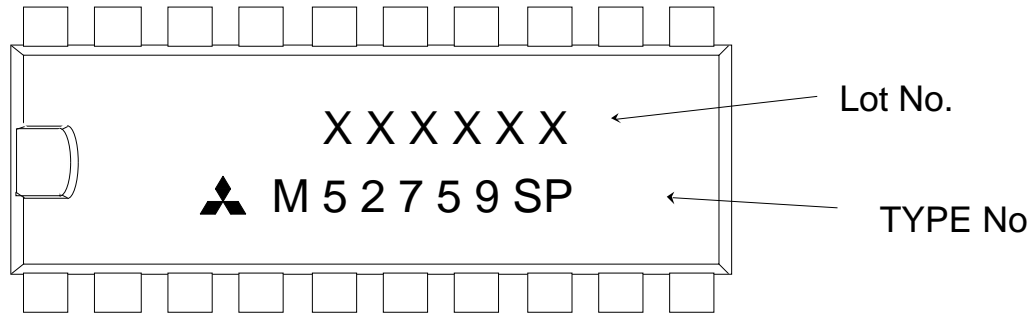

## 6. Material

Frame	Copper alloy
Lead plating	Solder plating
Resin	Epoxy resin

## 7. Factory of massproduction

FUKUOKA Factory