

DRAM MODULE

M53233200CE0/CJ0-C

4Byte 32Mx32 SIMM

(16Mx4 base)

DataSheet4U.com

DataShee

Revision 0.0

June 1999



DRAM MODULE

M53233200CE0/CJ0-C

Revision History

Version 0.0 (June 1999)

- The 4th. generation of 64Mb DRAM components are applied for this module.

et4U.com

DataSheet4U.com

DataShe



DRAM MODULE**M53233200CE0/CJ0-C****M53233200CE0/CJ0-C EDO Mode**

32M x 32 DRAM SIMM Using 16Mx4, 4K Refresh, 5V

GENERAL DESCRIPTION

The Samsung M53233200CE0/CJ0-C is a 32Mx32bits Dynamic RAM high density memory module. The Samsung M53233200CE0/CJ0-C consists of sixteen CMOS 16Mx4bits DRAMs in SOJ packages mounted on a 72-pin glass-epoxy substrate. A 0.1 or 0.22uF decoupling capacitor is mounted on the printed circuit board for each DRAM. The M53233200CE0/CJ0-C is a Single In-line Memory Module with edge connections and is intended for mounting into 72 pin edge connector sockets.

PERFORMANCE RANGE

Speed	t _{RAC}	t _{CAC}	t _{RC}	t _{HPC}
-C50	50ns	13ns	84ns	20ns
-C60	60ns	15ns	104ns	25ns

FEATURES

- Part Identification
 - M53233200CE0-C(4K cycles/64ms Ref, SOJ, Solder)
 - M53233200CJ0-C(4K cycles/64ms Ref, SOJ, Gold)
- Extended Data Out Mode Operation
- $\overline{\text{CAS}}$ -before- $\overline{\text{RAS}}$ & Hidden Refresh capability
- $\overline{\text{RAS}}$ -only refresh capability
- TTL compatible inputs and outputs
- Single +5V±10% power supply
- JEDEC standard PDpin & pinout
- PCB : Height(1420mil), double sided component

PIN CONFIGURATIONS

Pin	Symbol	Pin	Symbol
1	V _{ss}	37	NC
2	DQ0	38	NC
3	DQ18	39	V _{ss}
4	DQ1	40	$\overline{\text{CAS0}}$
5	DQ19	41	$\overline{\text{CAS2}}$
6	DQ2	42	$\overline{\text{CAS3}}$
7	DQ20	43	$\overline{\text{CAS1}}$
8	DQ3	44	$\overline{\text{RAS0}}$
9	DQ21	45	$\overline{\text{RAS1}}$
10	V _{cc}	46	NC
11	NC	47	$\overline{\text{W}}$
12	A0	48	NC
13	A1	49	DQ9
14	A2	50	DQ27
15	A3	51	DQ10
16	A4	52	DQ28
17	A5	53	DQ11
18	A6	54	DQ29
19	A10	55	DQ12
20	DQ4	56	DQ30
21	DQ22	57	DQ13
22	DQ5	58	DQ31
23	DQ23	59	V _{cc}
24	DQ6	60	DQ32
25	DQ24	61	DQ14
26	DQ7	62	DQ33
27	DQ25	63	DQ15
28	A7	64	DQ34
29	A11	65	DQ16
30	V _{cc}	66	NC
31	A8	67	PD1
32	A9	68	PD2
33	$\overline{\text{RAS3}}$	69	PD3
34	$\overline{\text{RAS2}}$	70	PD4
35	NC	71	NC
36	NC	72	V _{ss}

PIN NAMES

Pin Name	Function
A0 - A11	Address Inputs
DQ0-7, DQ9-16 DQ18-25, DQ27-34	Data In/Out
$\overline{\text{W}}$	Read/Write Enable
$\overline{\text{RAS0}}$ - $\overline{\text{RAS3}}$	Row Address Strobe
$\overline{\text{CAS0}}$ - $\overline{\text{CAS3}}$	Column Address Strobe
PD1 -PD4	Presence Detect
V _{cc}	Power(+5V)
V _{ss}	Ground
NC	No Connection

PRESENCE DETECT PINS (Optional)

Pin	50NS	60NS
PD1	NC	NC
PD2	V _{ss}	V _{ss}
PD3	V _{ss}	NC
PD4	V _{ss}	NC

SAMSUNG ELECTRONICS CO., LTD. reserves the right to change products and specifications without notice.



DRAM MODULE

M53233200CE0/CJ0-C

FUNCTIONAL BLOCK DIAGRAM

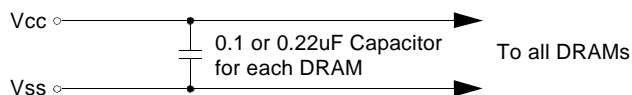
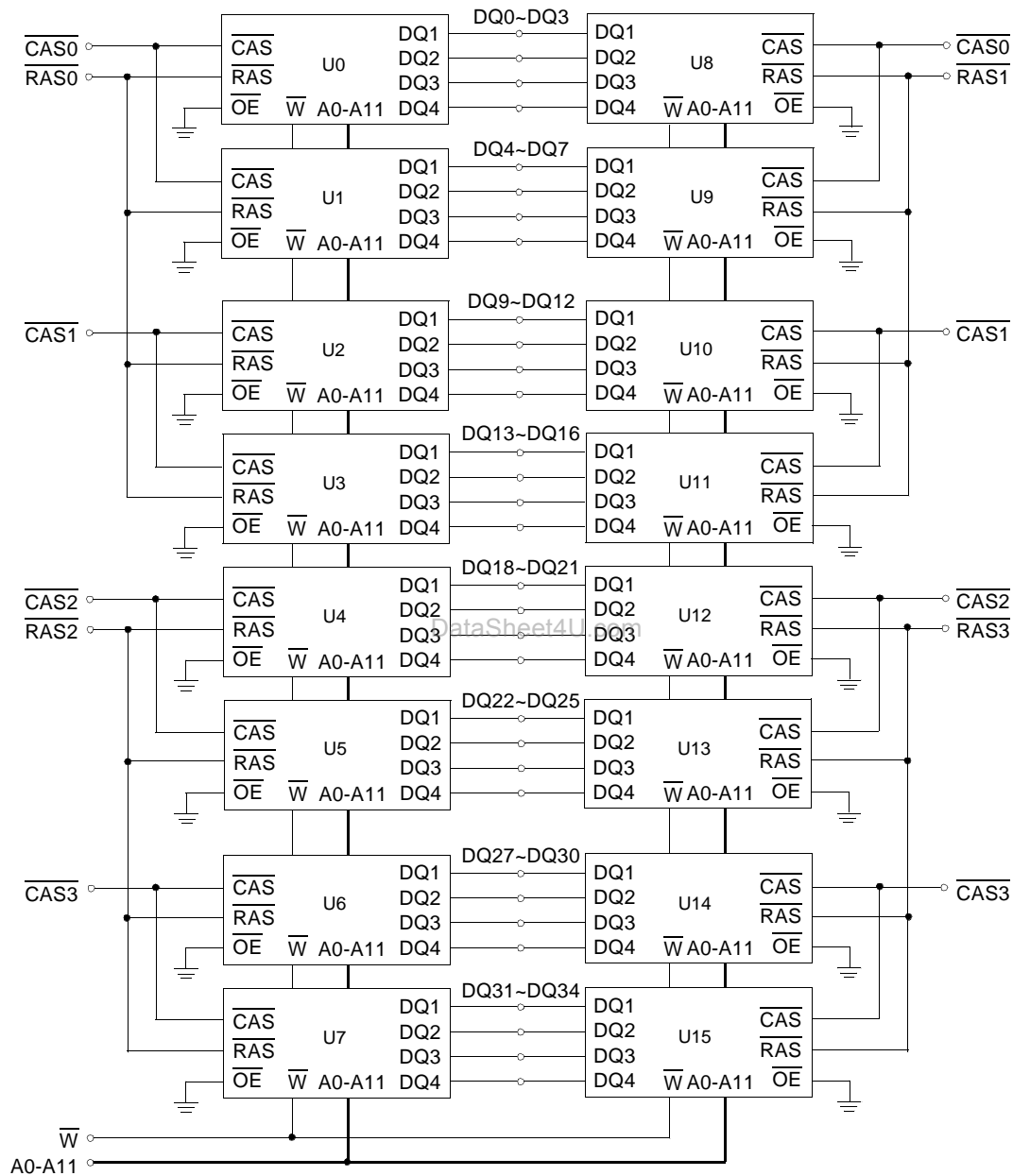

DRAM MODULE

M53233200CE0/CJ0-C

ABSOLUTE MAXIMUM RATINGS *

Item	Symbol	Rating	Unit
Voltage on any pin relative to V _{SS}	V _{IN} , V _{OUT}	-1 to +7.0	V
Voltage on V _{CC} supply relative to V _{SS}	V _{CC}	-1 to +7.0	V
Storage Temperature	T _{stg}	-55 to +125	°C
Power Dissipation	P _d	16	W
Short Circuit Output Current	I _{OS}	50	mA

* Permanent device damage may occur if ABSOLUTE MAXIMUM RATINGS are exceeded. Functional operation should be restricted to the conditions as detailed in the operational sections of this data sheet. Exposure to absolute maximum rating conditions for intended periods may affect device reliability.

RECOMMENDED OPERATING CONDITIONS (Voltage referenced to V_{SS}, T_A = 0 to 70°C)

Item	Symbol	Min	Typ	Max	Unit
Supply Voltage	V _{CC}	4.5	5.0	5.5	V
Ground	V _{SS}	0	0	0	V
Input High Voltage	V _{IH}	2.4	-	V _{CC} ^{*1}	V
Input Low Voltage	V _{IL}	-1.0 ^{*2}	-	0.8	V

*1 : V_{CC}+2.0V at pulse width ≤ 20ns, which is measured at V_{CC}.

*2 : -2.0V at pulse width ≤ 20ns, which is measured at V_{SS}.

DC AND OPERATING CHARACTERISTICS (Recommended operating conditions unless otherwise noted)

Symbol	Speed	M53233200CE0/CJ0		Unit
		Min	Max	
I _{CC1}	-50	-	976	mA
	-60	-	896	mA
I _{CC2}	Don't care	-	32	mA
I _{CC3}	-50	-	976	mA
	-60	-	896	mA
I _{CC4}	-50	-	896	mA
	-60	-	816	mA
I _{CC5}	Don't care	-	16	mA
I _{CC6}	-50	-	976	mA
	-60	-	896	mA
I _{I(L)}	Don't care	-10	10	µA
I _{O(L)}		-10	10	µA
V _{OH}	Don't care	2.4	-	V
V _{OL}		-	0.4	V

I_{CC1} : Operating Current * ($\overline{\text{RAS}}$, $\overline{\text{CAS}}$, Address cycling @trc=min)

I_{CC2} : Standby Current ($\overline{\text{RAS}}=\overline{\text{CAS}}=\overline{\text{W}}=\text{VIH}$)

I_{CC3} : $\overline{\text{RAS}}$ Only Refresh Current * ($\overline{\text{CAS}}=\text{VIH}$, $\overline{\text{RAS}}$ cycling @trc=min)

I_{CC4} : Hyper Page Mode Current * ($\overline{\text{RAS}}=\text{VIL}$, $\overline{\text{CAS}}$ cycling : t_{HPC}=min)

I_{CC5} : Standby Current ($\overline{\text{RAS}}=\overline{\text{CAS}}=\overline{\text{W}}=\text{Vcc}-0.2\text{V}$)

I_{CC6} : $\overline{\text{CAS}}$ -Before- $\overline{\text{RAS}}$ Refresh Current * ($\overline{\text{RAS}}$ and $\overline{\text{CAS}}$ cycling @trc=min)

I_{I(L)} : Input Leakage Current (Any input 0 ≤ V_{IN} ≤ V_{CC}+0.5V, all other pins not under test=0 V)

I_{O(L)} : Output Leakage Current(Data Out is disabled, 0V ≤ V_{OUT} ≤ V_{CC})

V_{OH} : Output High Voltage Level (I_{OH} = -5mA)

V_{OL} : Output Low Voltage Level (I_{OL} = 4.2mA)

* **NOTE** : I_{CC1}, I_{CC3}, I_{CC4} and I_{CC6} are dependent on output loading and cycle rates. Specified values are obtained with the output open. I_{CC} is specified as an average current. In I_{CC1} and I_{CC3}, address can be changed maximum once while $\overline{\text{RAS}}=\text{VIL}$. In I_{CC4}, address can be changed maximum once within one EDO mode cycle time, t_{HPC}.



DRAM MODULE

M53233200CE0/CJ0-C

CAPACITANCE (TA = 25°C, VCC=5V, f = 1MHz)

Item	Symbol	Min	Max	Unit
Input capacitance[A0-A11]	CIN1	-	90	pF
Input capacitance[W]	CIN2	-	122	pF
Input capacitance[RAS0 - RAS3]	CIN3	-	38	pF
Input capacitance[CAS0 - CAS3]	CIN4	-	38	pF
Input/Output capacitance[DQ0-7, 9-16,18-25, 27-34]	CDQ	-	17	pF

AC CHARACTERISTICS (0°C≤TA≤70°C, Vcc=5.0V±10%. See notes 1,2.)

Test condition : Vin/Vii=2.4/0.8V, Voh/Vol=2.0/0.8V, output loading CL=100pF

Parameter	Symbol	-50		-60		Unit	Note
		Min	Max	Min	Max		
Random read or write cycle time	tRC	84		104		ns	
Access time from RAS	tRAC		50		60	ns	3,4,10
Access time from CAS	tCAC		13		15	ns	3,4,5
Access time from column address	tAA		25		30	ns	3,10
CAS to output in Low-Z	tCLZ	3		3		ns	3
Output buffer turn-off delay from CAS	tCEZ	3	13	3	13	ns	6,12
Transition time(rise and fall)	tT	1	50	1	50	ns	2
RAS precharge time	tRP	30		40		ns	
RAS pulse width	tRAS	50	10K	60	10K	ns	
RAS hold time	tRSH	13		15		ns	
CAS hold time	tCSH	38		45		ns	
CAS pulse width	tCAS	8	10K	10	10K	ns	4
RAS to CAS delay time	tRCD	20	37	20	45	ns	9
RAS to column address delay time	tRAD	15	25	15	30	ns	
CAS to RAS precharge time	tCRP	5		5		ns	
Row address set-up time	tASR	0		0		ns	
Row address hold time	tRAH	10		10		ns	
Column address set-up time	tASC	0		0		ns	
Column address hold time	tCAH	8		10		ns	
Column address to RAS lead time	tRAL	25		30		ns	
Read command set-up time	tRCS	0		0		ns	
Read command hold referenced to CAS	tRCH	0		0		ns	8
Read command hold referenced to RAS	tRRH	0		0		ns	8
Write command set-up time	tWCS	0		0		ns	7
Write command hold time	tWCH	10		10		ns	
Write command pulse width	tWP	10		10		ns	
Write command to RAS lead time	tRWL	13		15		ns	
Write command to CAS lead time	tCWL	8		10		ns	
Data set-up time	tDS	0		0		ns	9
Data hold time	tDH	8		10		ns	9
Refresh period	tREF		64		64	ms	
CAS setup time (CAS-before-RAS refresh)	tCSR	5		5		ns	
CAS hold time (CAS-before-RAS refresh)	tCHR	10		10		ns	
RAS to CAS precharge time	tRPC	5		5		ns	
Access time from CAS precharge	tCPA		28		35	ns	3



DRAM MODULE

M53233200CE0/CJ0-C

AC CHARACTERISTICS (0°C≤T_A≤70°C, V_{CC}=5.0V±10%. See notes 1,2.)Test condition : V_{IH}/V_{IL}=2.4/0.8V, V_{OH}/V_{OL}=2.0/0.8V, output loading CL=100pF

Parameter	Symbol	-50		-60		Unit	Note
		Min	Max	Min	Max		
Hyper page mode cycle time	t _{HPC}	20		25		ns	11
CAS precharge time (Hyper page cycle)	t _{CP}	8		10		ns	
RAS pulse width (Hyper page cycle)	t _{RASP}	50	200K	60	200K	ns	
RAS hold time from CAS precharge	t _{RHCP}	30		35		ns	
W to RAS precharge time(C-B-R refresh)	t _{WRP}	10		10		ns	
W to RAS hold time(C-B-R refresh)	t _{WRH}	10		10		ns	
Output data hold time	t _{DOH}	5		5		ns	
Output buffer turn off delay from RAS	t _{REZ}	3	13	3	15	ns	6,12
Output buffer turn off delay from W	t _{WEZ}	3	13	3	15	ns	6
W to data delay	t _{WED}	15		15		ns	
W pulse width	t _{WPE}	5		5		ns	

NOTES

- An initial pause of 200us is required after power-up followed by any 8 RAS-only or CAS-before-RAS refresh cycles before proper device operation is achieved.
- Input voltage levels are V_{IH}/V_{IL}. V_{IH}(min) and V_{IL}(max) are reference levels for measuring timing of input signals. Transition times are measured between V_{IH}(min) and V_{IL}(max) and are assumed to be 5ns for all inputs.
- Measured with a load equivalent to 2 TTL loads and 100pF.
- Operation within the t_{RCD}(max) limit insures that t_{RAC}(max) can be met. t_{RCD}(max) is specified as a reference point only. If t_{RCD} is greater than the specified t_{RCD}(max) limit, then access time is controlled exclusively by t_{CAC}.
- Assumes that t_{RCD}≥t_{RCD}(max).
- This parameter defines the time at which the output achieves the open circuit and is not referenced for V_{OH} or V_{OL}.
- t_{WCS} is non-restrictive operating parameter. It is included in the data sheet as electrical characteristics only. If t_{WCS}≥t_{WCS}(min), the cycle is an early write cycle and the data out pin will remain high impedance for the duration of the cycle.
- Either t_{RCH} or t_{RRH} must be satisfied for a read cycle.
- These parameters are referenced to the CAS leading edge in early write cycles.
- Operation within the t_{RAD}(max) limit insures that t_{RAC}(max) can be met. t_{RAD}(max) is specified as reference point only. If t_{RAD} is greater than the specified t_{RAD}(max) limit access time is controlled by t_{AA}.
- t_{ASC}≥6ns, Assume t_T=2.0ns.
- If RAS goes high before CAS high going, the open circuit condition of the output is achieved by CAS high going. If CAS goes high before RAS high going, the open circuit condition of the output is achieved by RAS going.

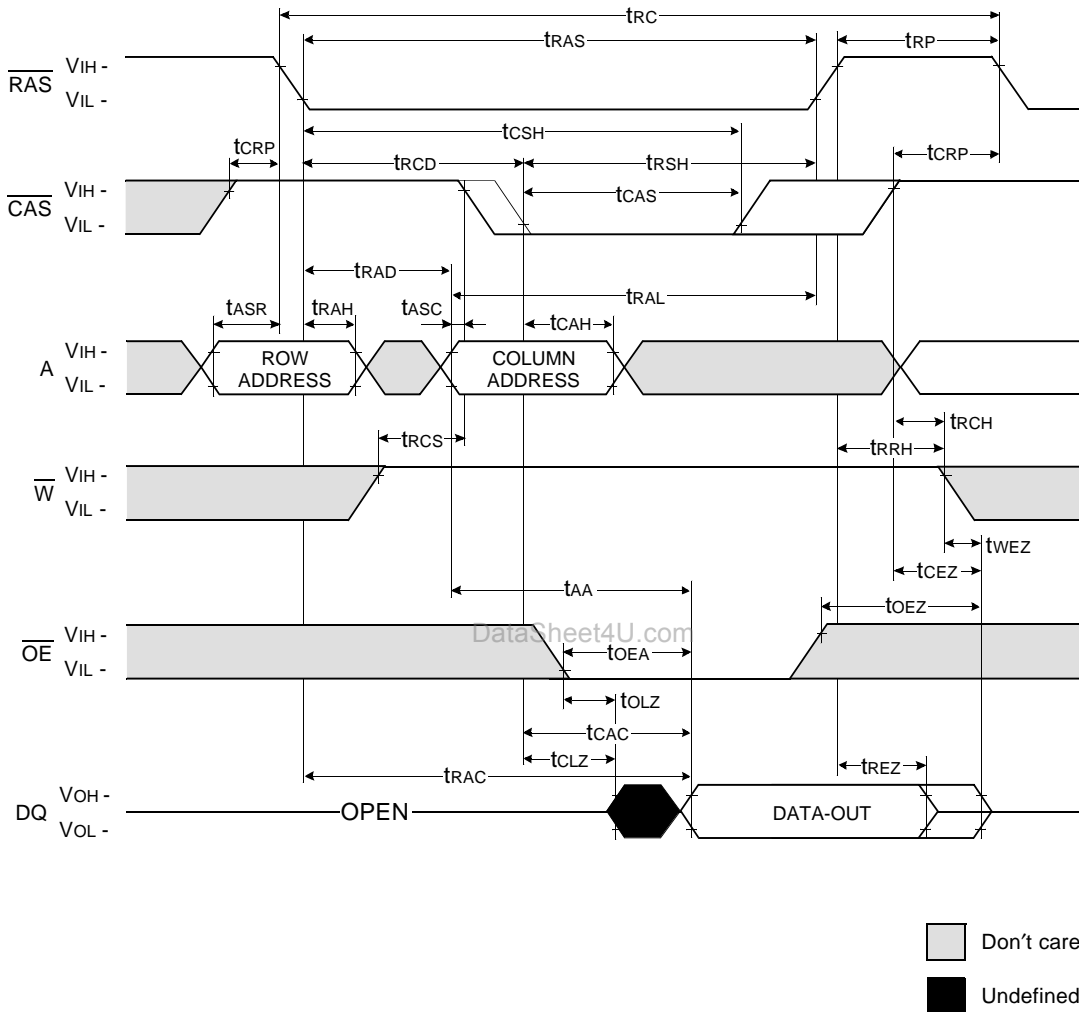

DRAM MODULE**M53233200CE0/CJ0-C****READ CYCLE**

DRAM MODULE

M53233200CE0/CJ0-C

WRITE CYCLE (EARLY WRITE)

NOTE : DOUT = OPEN

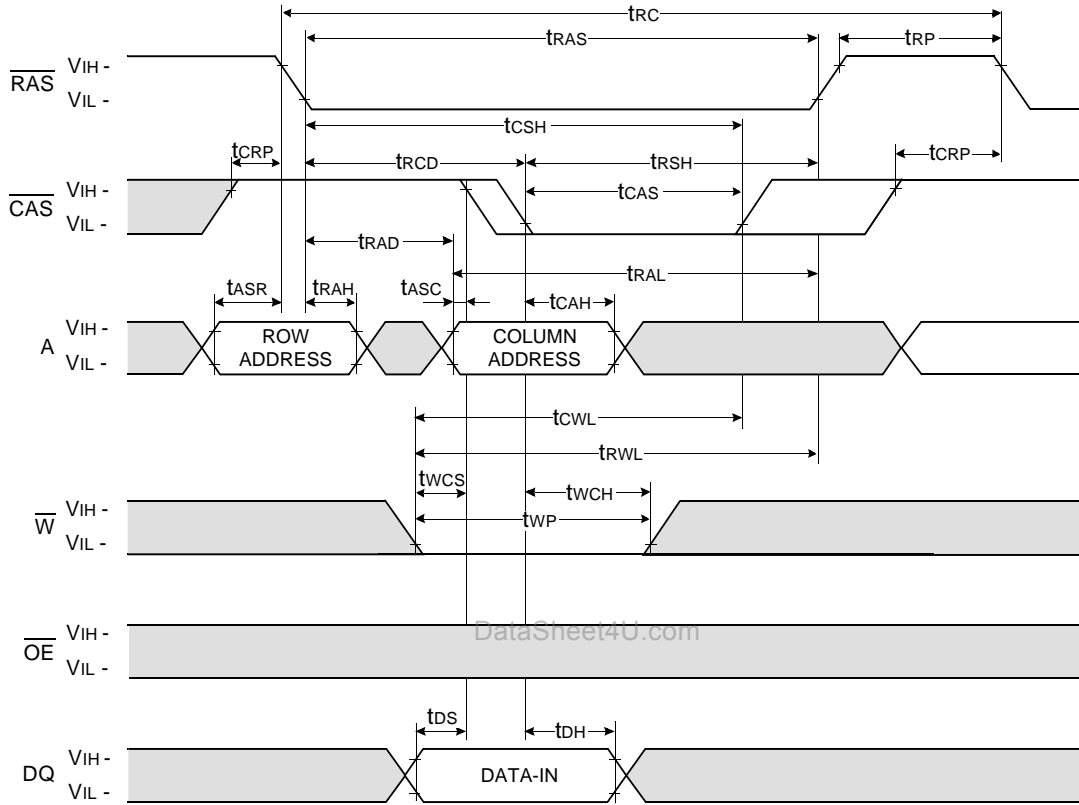

Don't care
 Undefined



DRAM MODULE

M5233200CE0/CJ0-C

WRITE CYCLE (\overline{OE} CONTROLLED WRITE)

NOTE : DOUT = OPEN

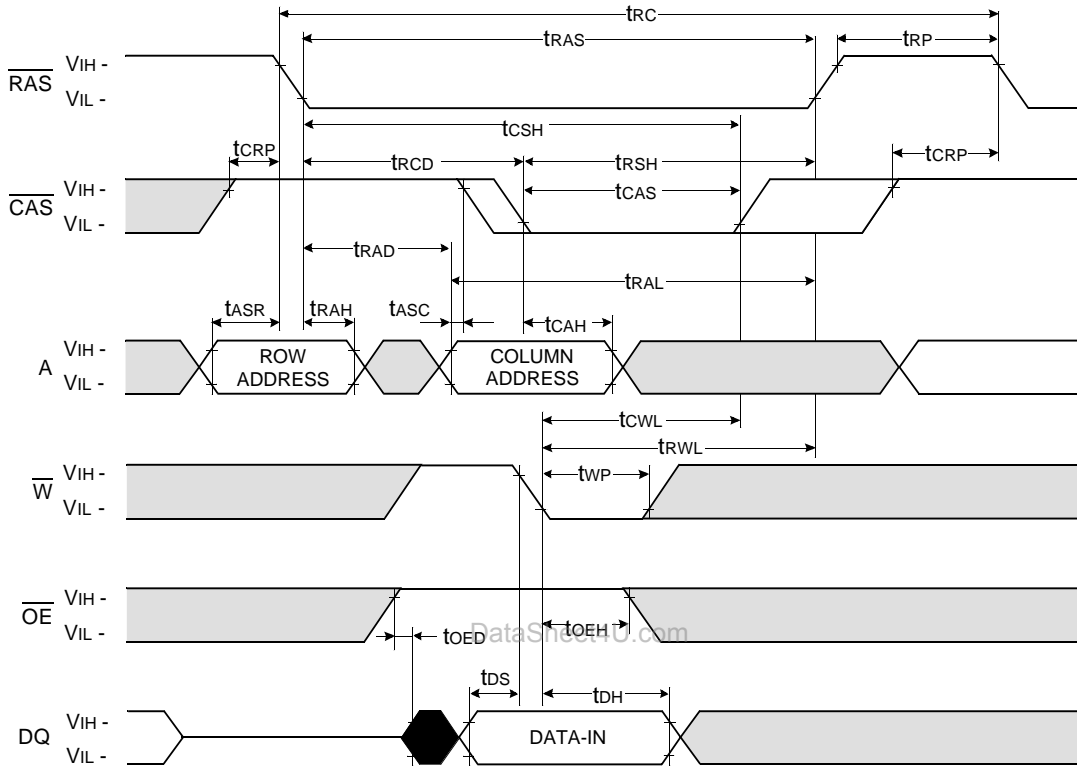

DRAM MODULE

M53233200CE0/CJ0-C

READ - MODIFY - WRITE CYCLE

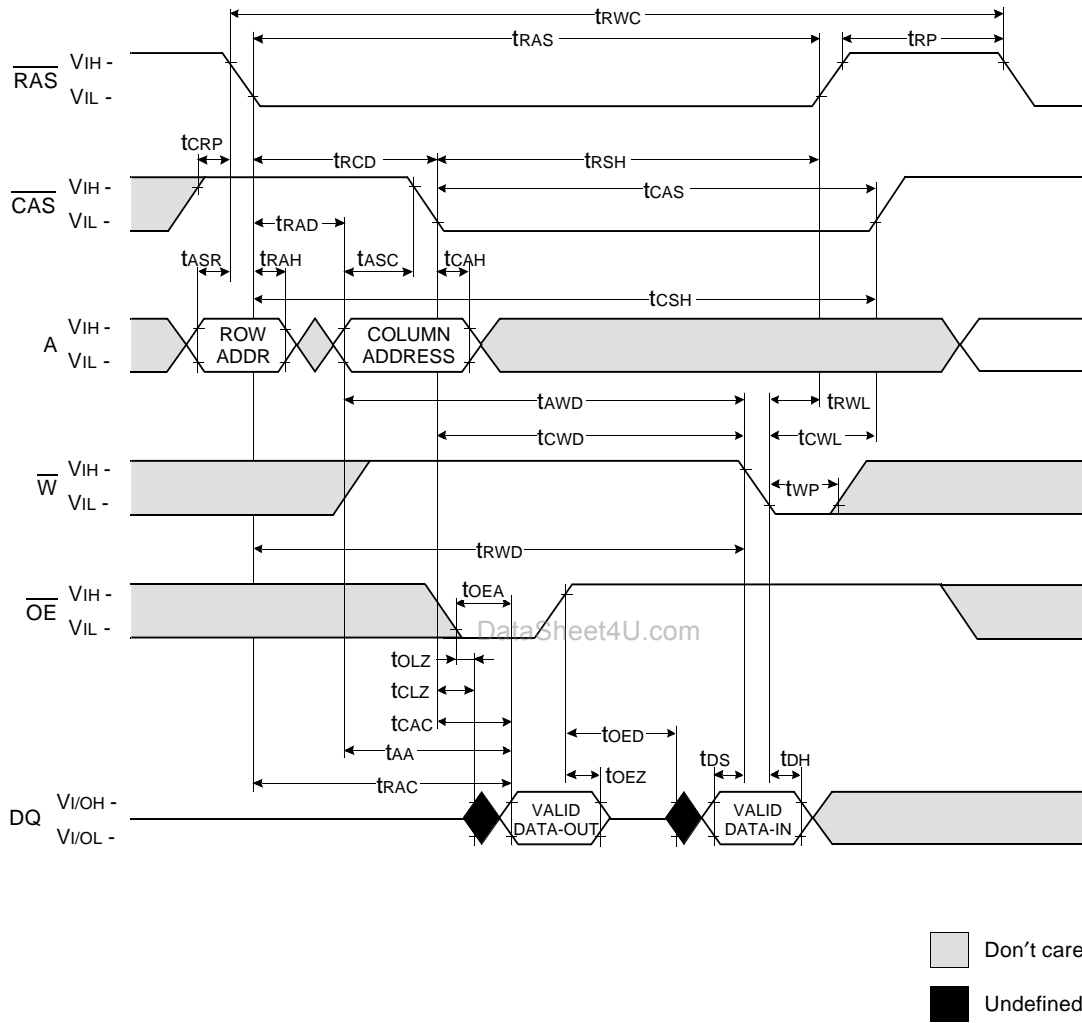

DRAM MODULE

M53233200CE0/CJ0-C

HYPER PAGE READ CYCLE

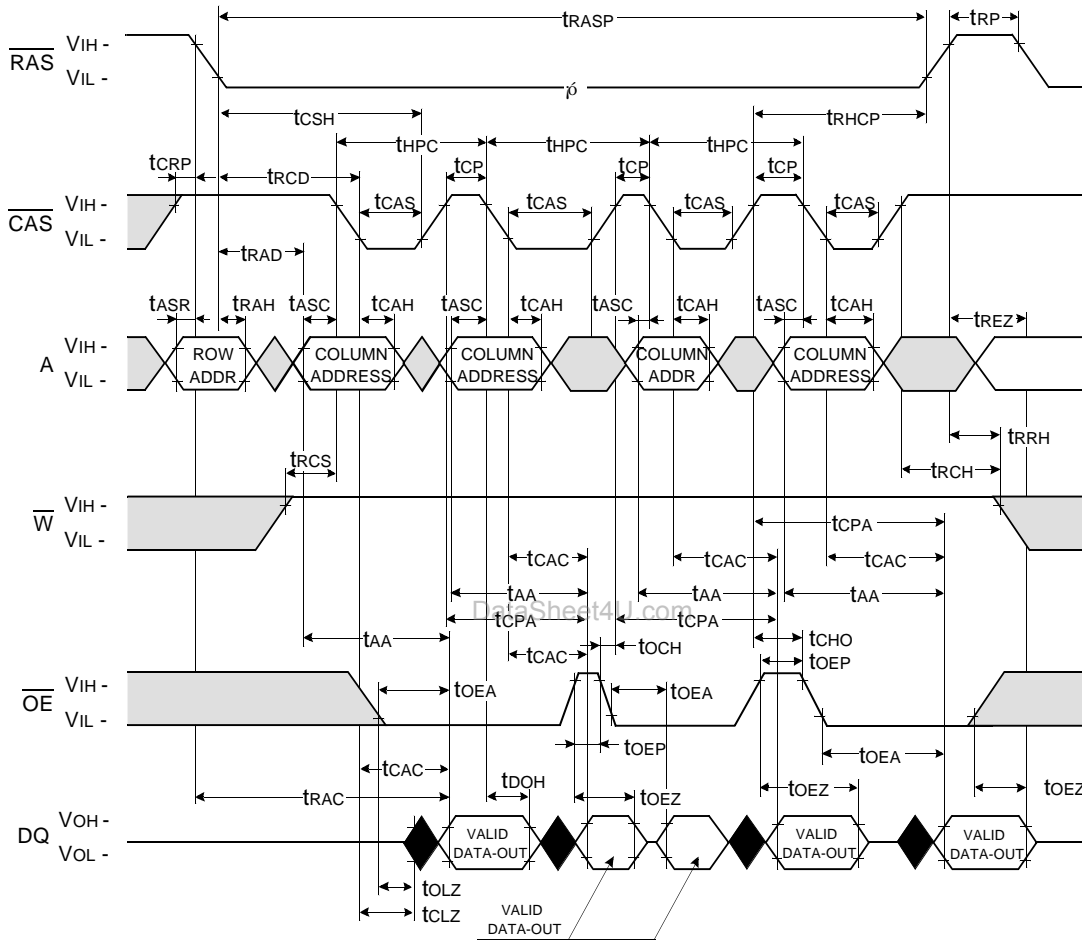

Don't care
 Undefined



DRAM MODULE

M53233200CE0/CJ0-C

HYPER PAGE WRITE CYCLE (EARLY WRITE)

NOTE : DOUT = OPEN

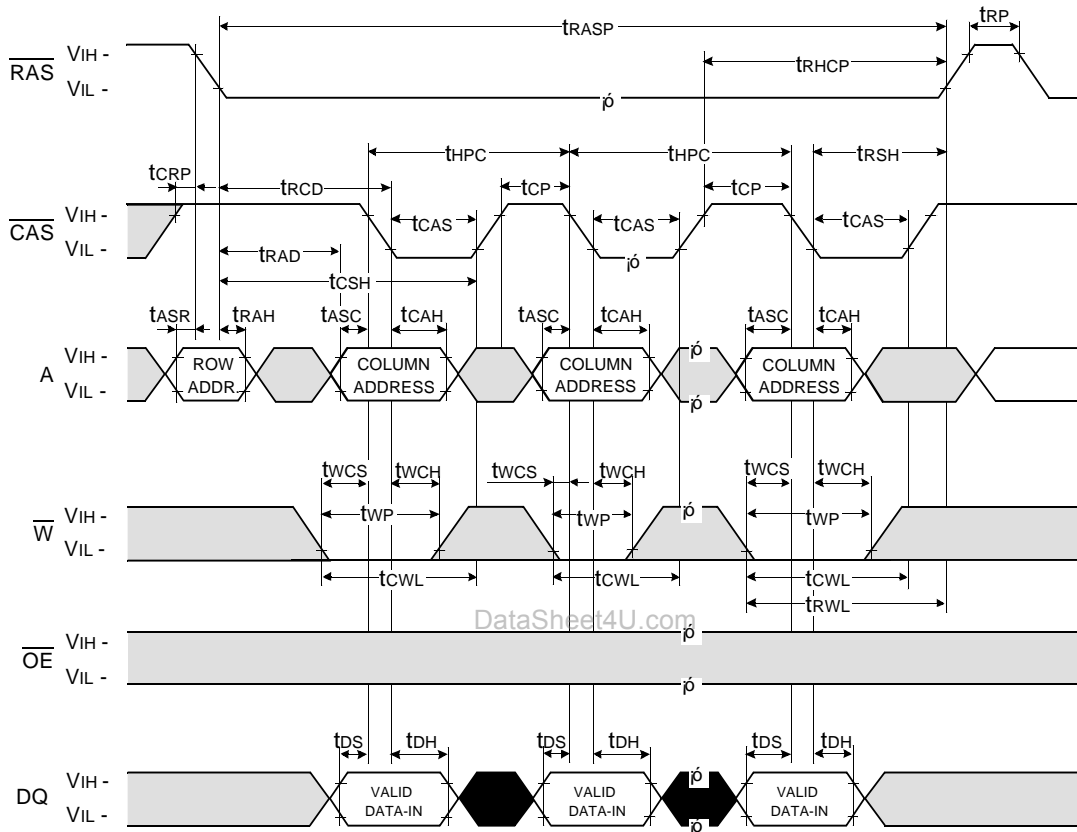

Don't care
 Undefined



ELECTRONICS

DRAM MODULE

M53233200CE0/CJ0-C

HYPER PAGE READ-MODIFY-WRITE CYCLE

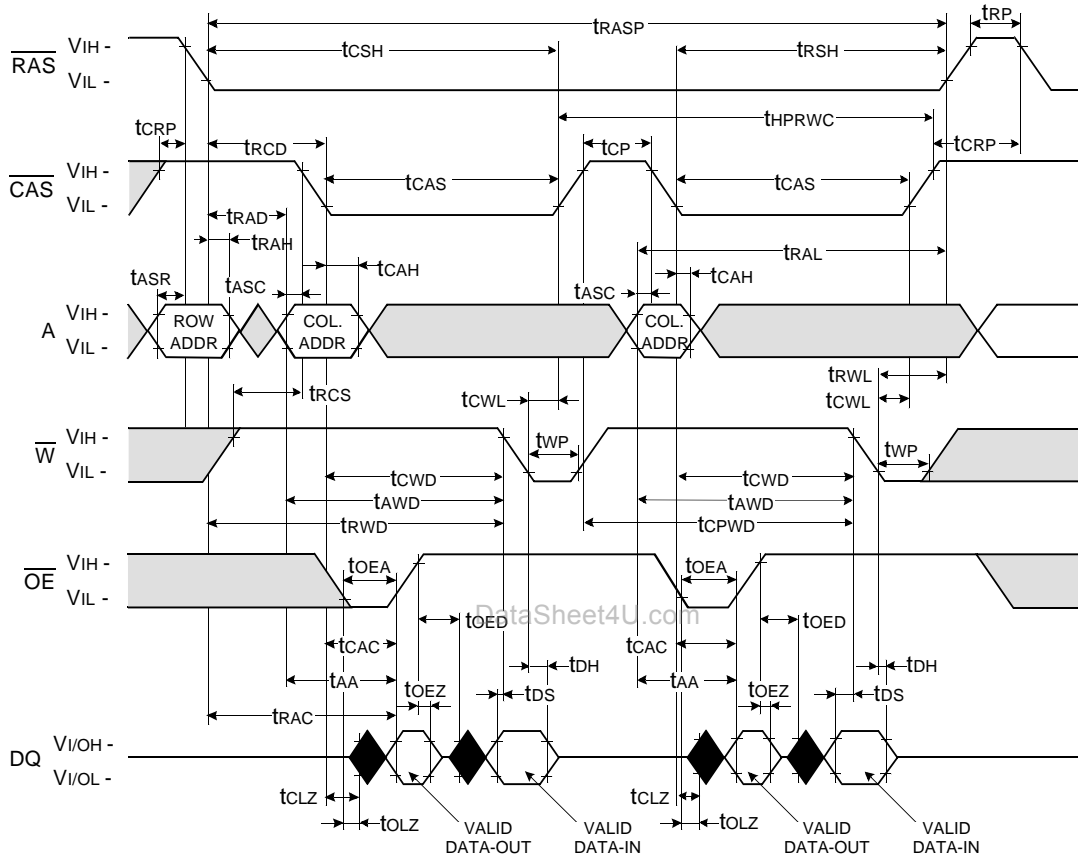

Don't care
Undefined



DRAM MODULE

M53233200CE0/CJ0-C

HYPER PAGE READ AND WRITE MIXED CYCLE

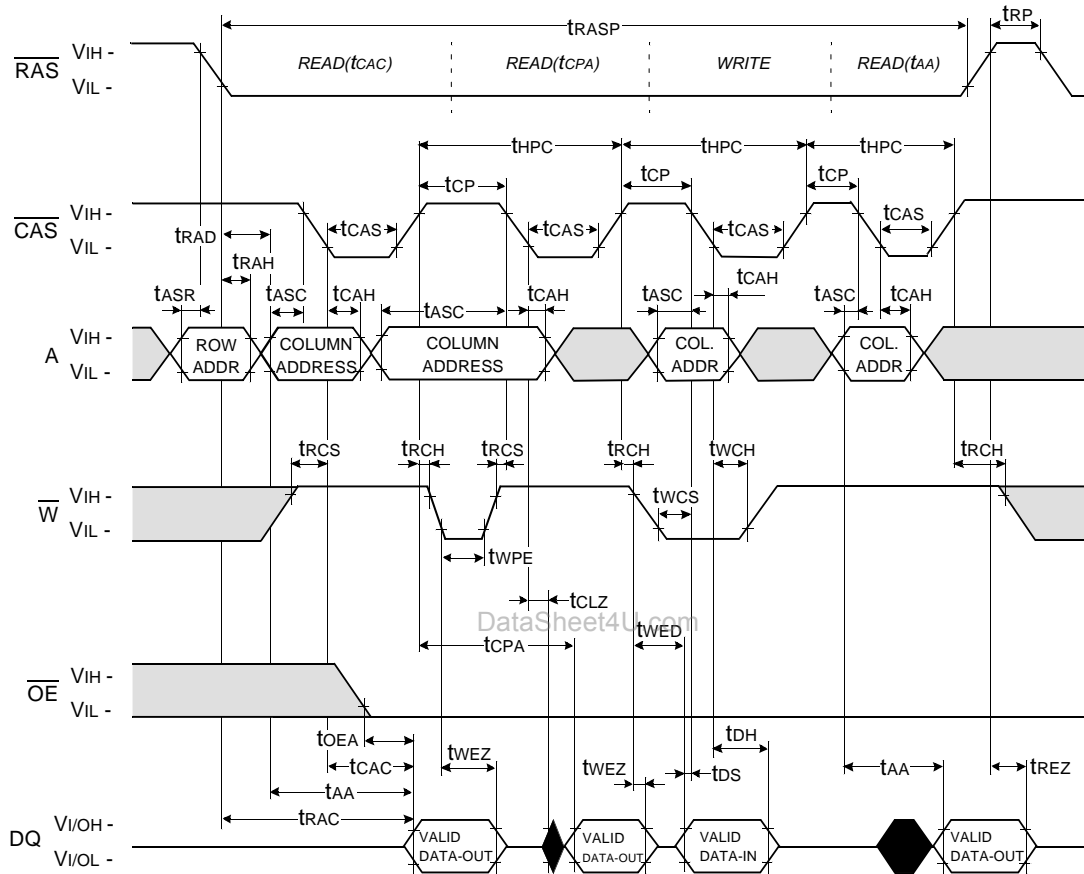

Don't care
 Undefined



DRAM MODULE**M53233200CE0/CJ0-C** **$\overline{\text{RAS}}$ - ONLY REFRESH CYCLE***NOTE : $\overline{\text{W}}$, $\overline{\text{OE}}$, DIN = Don't care

DOUT = OPEN

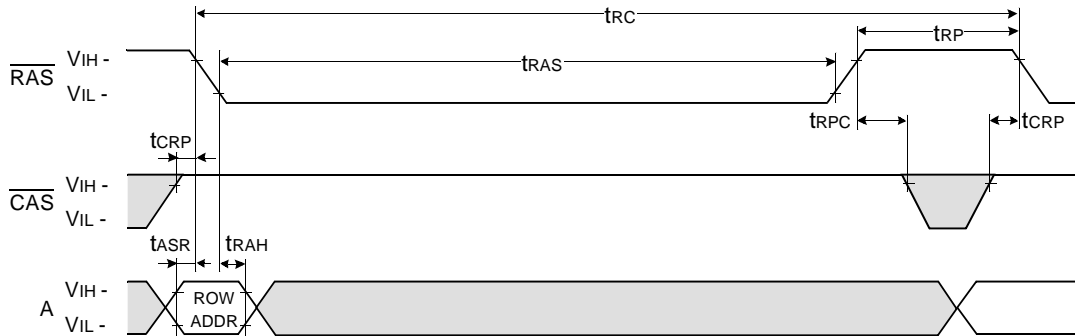
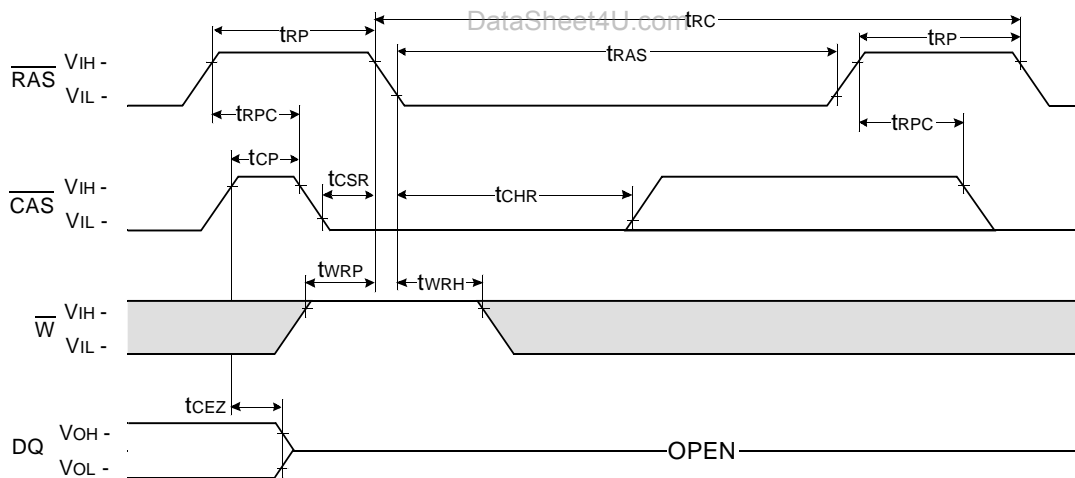
 **$\overline{\text{CAS}}$ - BEFORE - $\overline{\text{RAS}}$ REFRESH CYCLE**NOTE : $\overline{\text{OE}}$, A = Don't care

Don't care

Undefined

* In $\overline{\text{RAS}}$ -only refresh cycle of 64Mb A-die & B-die, when $\overline{\text{CAS}}$ signal transits from Low to High, the valid data may be cut off.

DRAM MODULE

M5233200CE0/CJ0-C

HIDDEN REFRESH CYCLE (WRITE)

NOTE : DOUT = OPEN

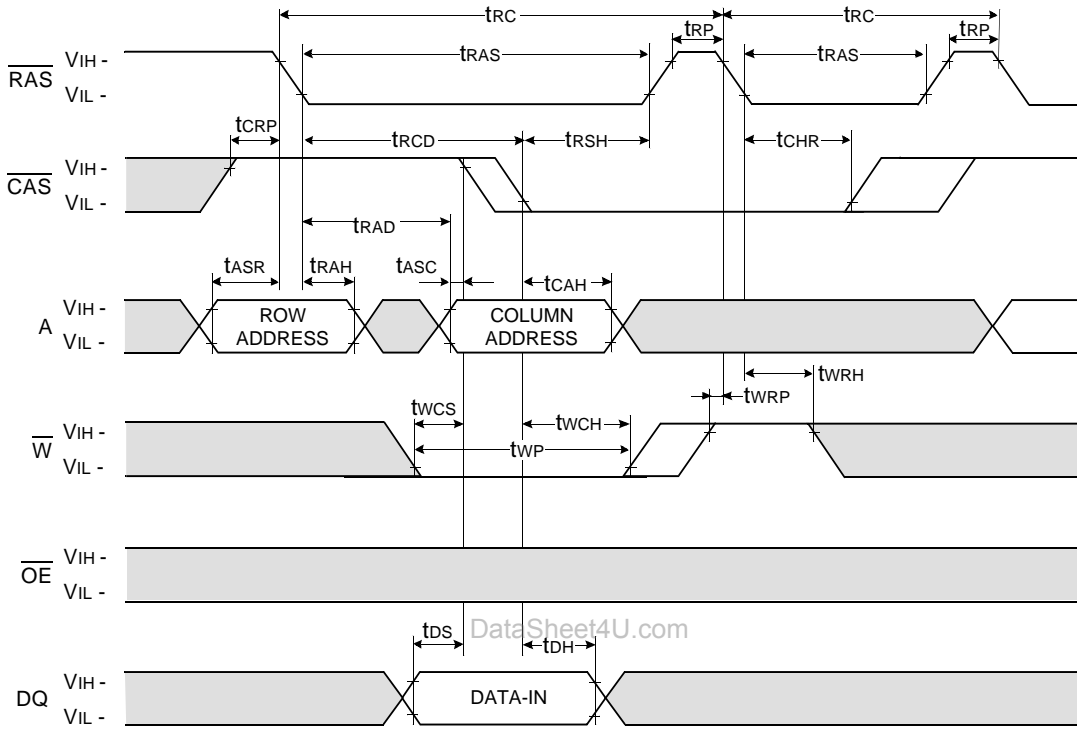

Don't care
 Undefined



DRAM MODULE

M53233200CE0/CJ0-C

CAS-BEFORE-RAS REFRESH CYCLE TEST CYCLE

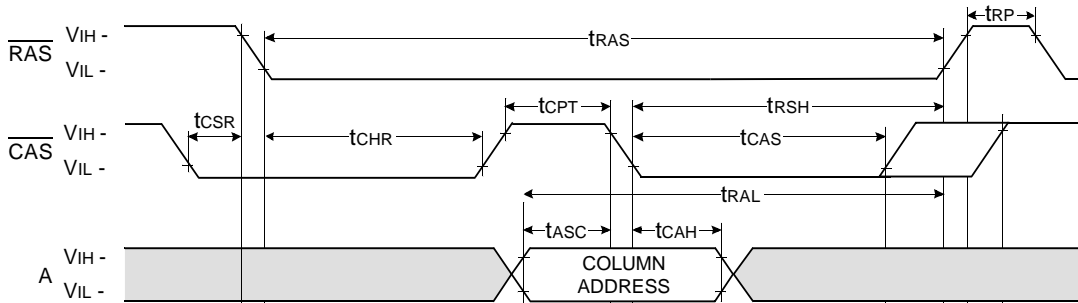

READ CYCLE

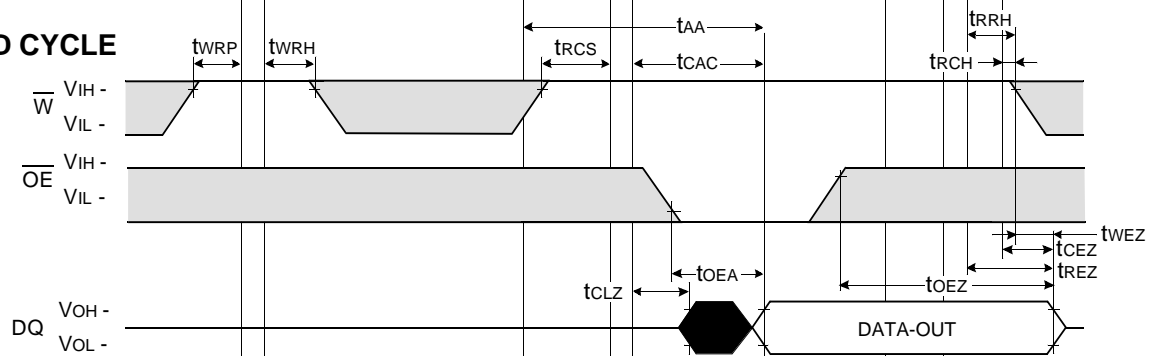

WRITE CYCLE

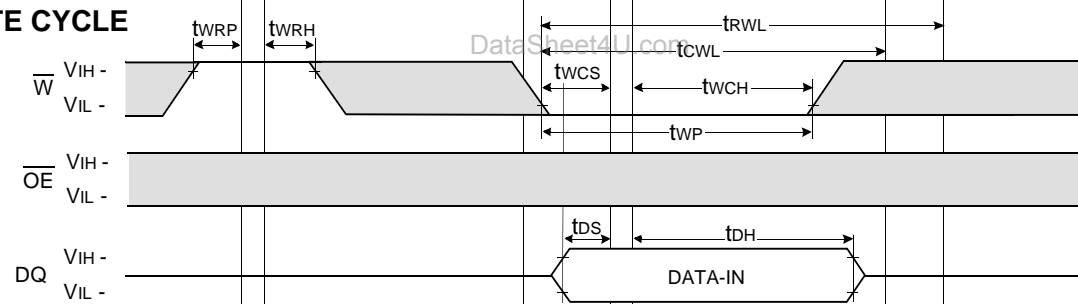

READ-MODIFY-WRITE

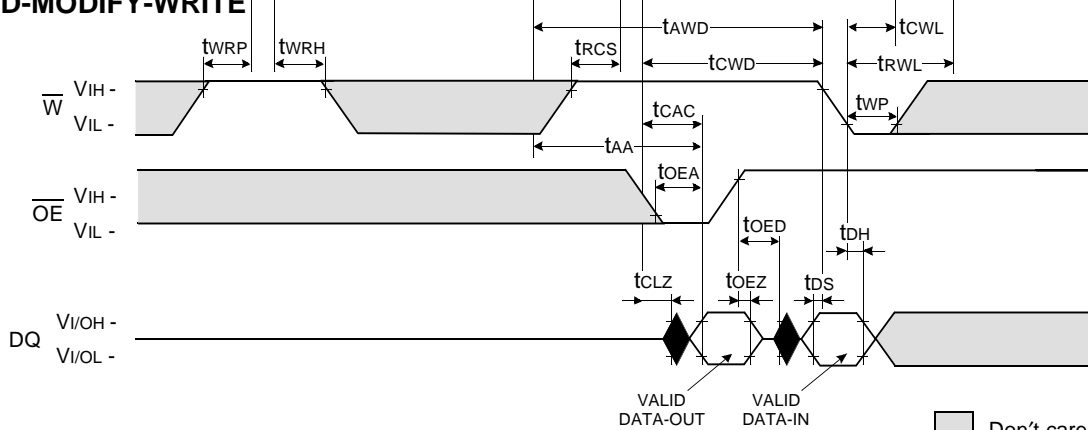

Don't care
 Undefined

NOTE : This timing diagram is applied to all devices besides 64M DRAM based modules.



DRAM MODULE

M53233200CE0/CJ0-C

CAS - BEFORE - RAS SELF REFRESH CYCLE

NOTE : \overline{OE} , A = Don't care

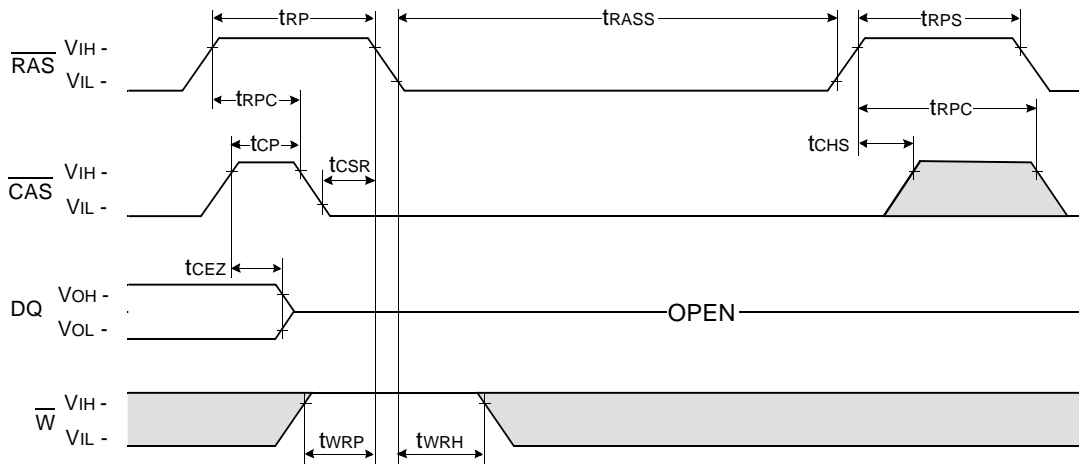

TEST MODE IN CYCLE

NOTE : \overline{OE} , A = Don't care

DataSheet4U.com

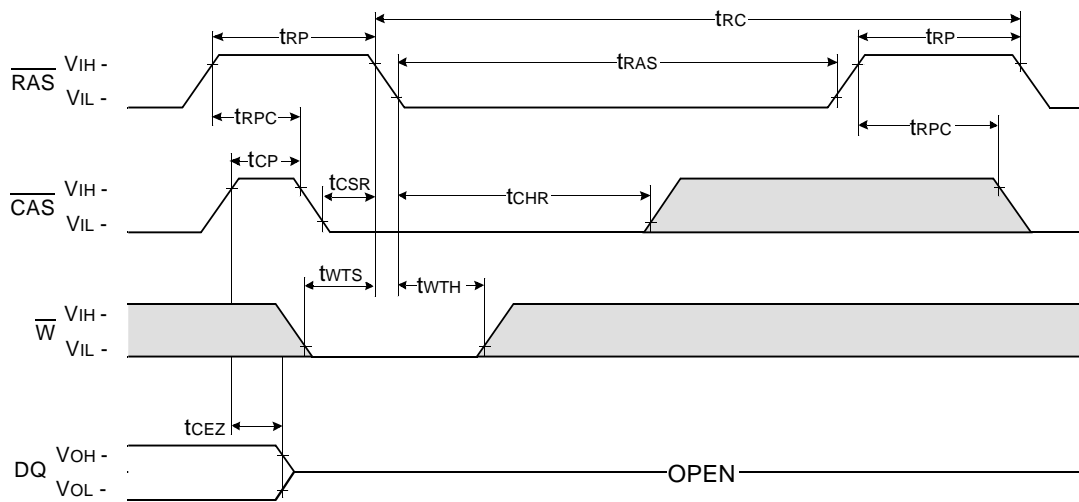

Don't care
 Undefined



ELECTRONICS

DRAM MODULE

M53233200CE0/CJ0-C

PACKAGE DIMENSIONS

Units : Inches (millimeters)



(Front view)

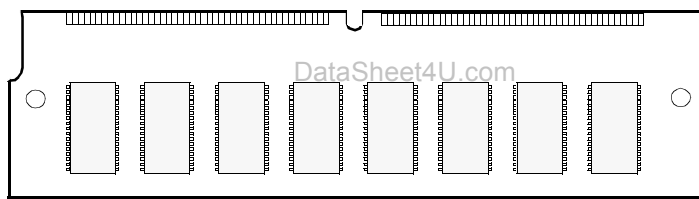

(Back view)

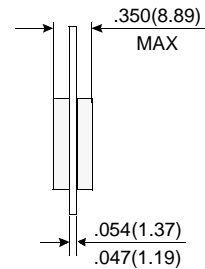

Gold/Solder Plating Lead

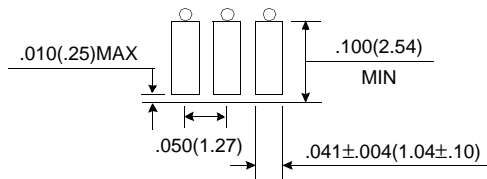

Tolerances : ±.005(.13) unless otherwise specified

NOTE : The used device is 16Mx4 DRAM, SOJ
 DRAM Part No. : M53233200CE0/CJ0 -- K4E640411C

