

M54125L/P

EARTH LEAKAGE CURRENT DETECTOR

DESCRIPTION

The M54125 is a semiconductor integrated circuit consisting of an amplifier for high-speed earth leakage circuit breaker.

FEATURES

- Satisfies JIS C 8371
- Temperature-stable input current trigger threshold ($V_{LKT} = 9mV$)
- Capable of detecting a lost phase on the neutral line
- Economical, low external component count
- Highly resistant to noise and power surges
- Wide operating temperature range ($T_a = -20 - +80^{\circ}C$)

APPLICATION

High-speed earth-leakage circuit breakers

FUNCTION

The M54125 is a semiconductor integrated circuit for use in the amplifier section of earth-leakage circuit breakers. It consists of a differential amplifier, one-shot circuit, output circuit, current regulator, waveform regulator and delay circuit. The following description refers to the block diagram, application example, and operational waveforms.

PIN CONFIGURATION (TOP VIEW)

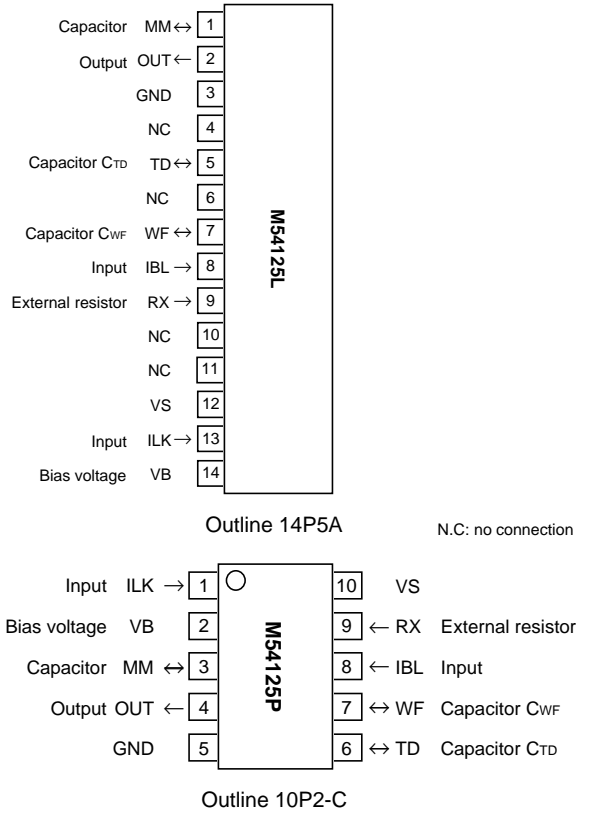

BLOCK DIAGRAM (Note: Pin No. in parentheses are of M54125L)

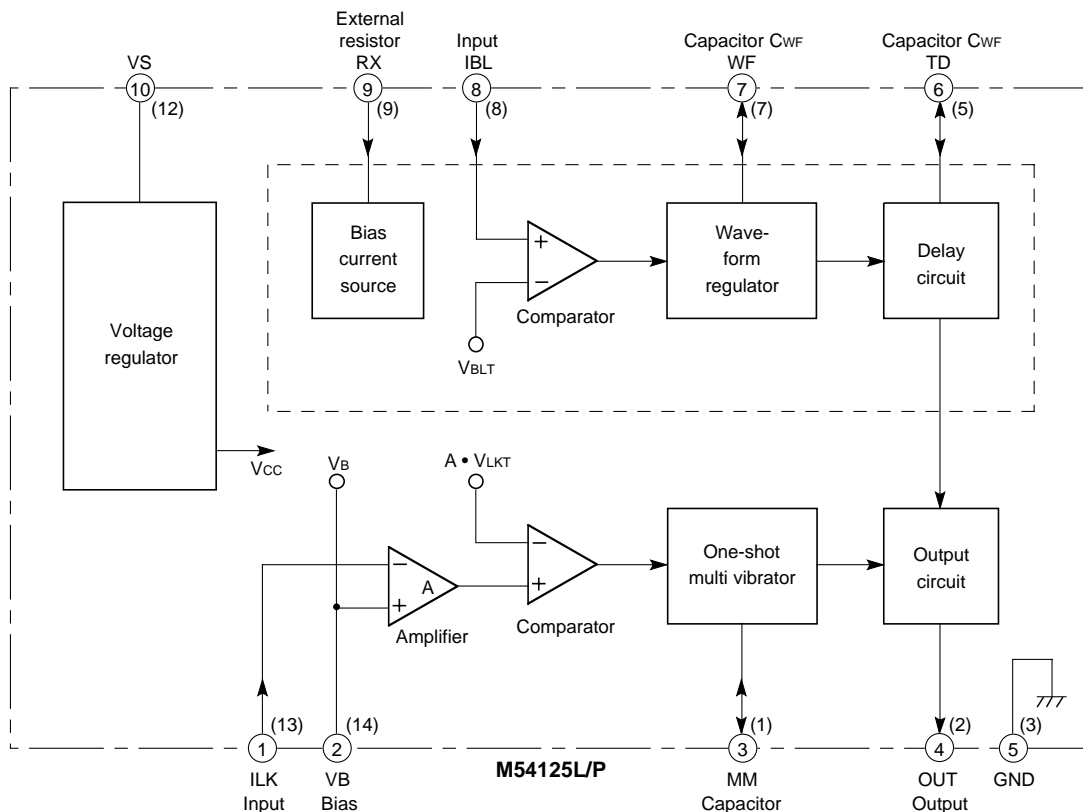

ABSOLUTE MAXIMUM RATINGS (Ta = -20 – 80°C unless otherwise noted)

Symbol	Parameter	Conditions	Ratings	Unit
Is	Supply voltage	Average supply current frequency per cycle	0 – 6	mA
Is(SO)	Supply surge current	(Note 1)	0 – 12	mA
ΔVILK	ILK input voltage	Pin VB serves as the voltage reference	-1.8 – +1.8	V
VIBL	IBL input voltage		-0.3 – 6	V
VOUT	OUT applied voltage	When external voltage is applied	-0.3 – 4	V
Pd	Power dissipation		160	mW
Topr	Operating temperature		-20 – 80	°C
Tstg	Storage temperature		-55 – 125	°C

Note 1: Is(SG) current waveform, which is given in the following diagram, shall be one shot or less per minute.

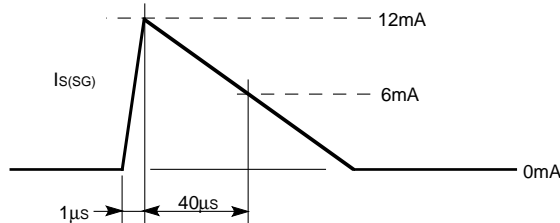

RECOMMENDED OPERATING CONDITIONS (Ta = -20 – 80°C unless otherwise noted)

Symbol	Parameter		Limits			Unit
			Min.	Typ.	Max.	
Vs	Supply voltage	When output OUT is OFF	12			V
Is	Supply current	Average power supply current per cycle			5.6	mA
CMM	External capacitor MM			0.22		μF
CWF	External capacitor WF			1		μF
CTD	External capacitor TD			6.8		μF
Rx	External resistor Rx			27		kΩ

Handling of unused pins when the abnormal voltage detection function is not used

- Pin Rx must be left open
- Pin TD must be shorted to GND
- Pin WF and pin IBL may be left open or shorted to GND

LEAKAGE DETECTION FUNCTION

When leakage current I_g appears on the primary side of zero-current transformer, ZCT, leakage signal voltage V_{ILK} appears on the secondary side and is input at ILK with bias V_B as the reference. In the half cycle when V_{ILK} is negative, capacitor C_{MM} connected to MM charges until V_{ILK} reaches the DC trip voltage.

If the voltage at MM does not reach the MM positive threshold voltage, when the charging phase is completed, capacitor C_{MM} discharges at a small current. The output OUT is reset to the off state (in which output current flows in) when V_{MM} descends to the MM negative threshold voltage.

Earth-leakage currents are detected when the amplitude of input voltage V_{ILK} exceeds the DC trip voltage V_{LKT} for longer than the detection time t_{MM} . The output OUT turns on for time t_{OUT} . The output current is used to turn on the thyristor that opens the breaker contacts.

ABNORMAL VOLTAGE DETECTION FUNCTION

Normally V_{IBL} , fixed amplitude AC supply that has been rectified and divided by a resistor, is input to abnormal voltage input IBL. When a fault occurs in the neutral line N, successive peaks of V_{IBL} become alternately small and large, with the levels determined by the load on the AC power lines A and B.

When the amplitude of V_{IBL} exceeds the abnormal voltage trip voltage V_{BLT} , capacitor C_{WF} connected to pin WF discharges. After the discharge phase is completed, charging begins again.) When voltage V_{WF} at WF drops below the WF threshold voltage, capacitor C_{TD} at TD charges, and after delay time t_{TD} , when voltage V_{TD} at TD reaches the TD threshold voltage, output OUT turns on, activating the circuit breaker. To avoid misoperation due to the effect of repeated one-shot noise that brings V_{IBL} above V_{BLT} , the voltage drops to the initial value only after time t_{WF} .

This abnormal voltage detection circuit is enabled only when an external resistor R_x is connected to pin Rx to enable the current flow.

WAVEFORM DIAGRAM

1) Voltage waveform when earth leakage is detected.

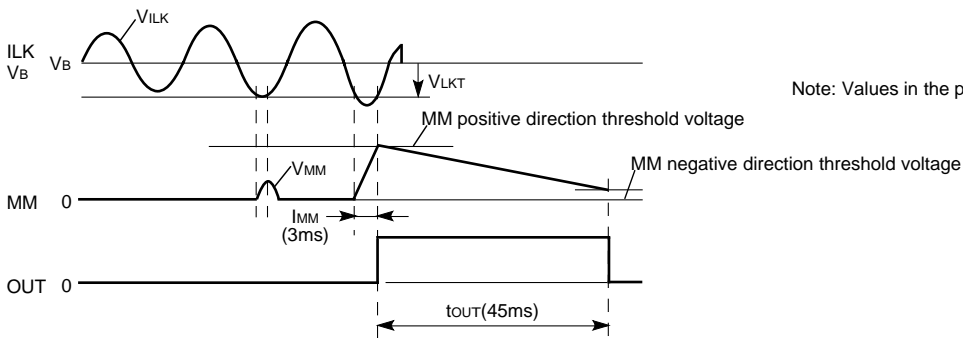

Note: Values in the parentheses are for reference only.

2) Voltage waveform when abnormal voltage is detected.

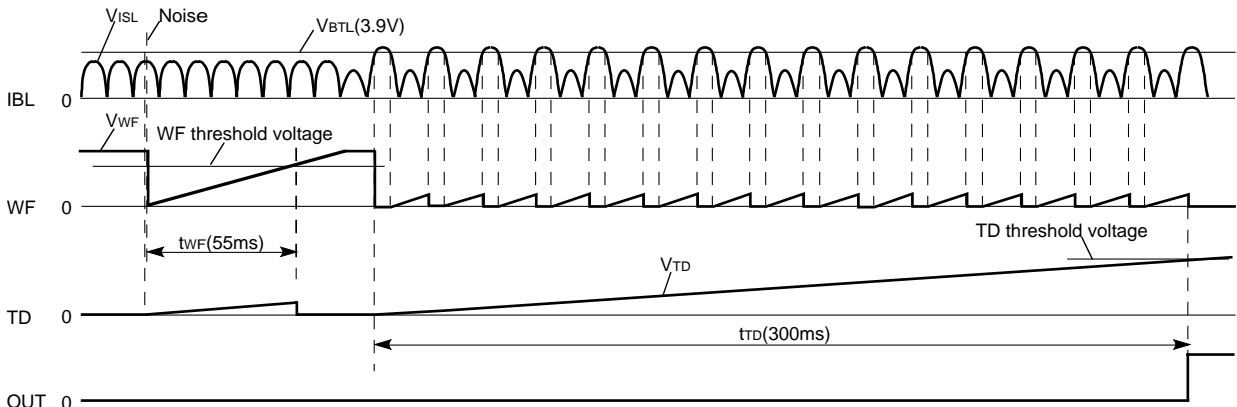

M54125L/P

EARTH LEAKAGE CURRENT DETECTOR

ELECTRICAL CHARACTERISTICS (Vcc = 5V and Ta = -20 – 80°C unless otherwise noted)

Symbol	Parameter	Test conditions	Temperature	Limits		Unit	Test circuit	
				Min.	Max.			
Is1	Supply current 1	Pin VS	Vs = 12V, ΔVILK = 0mV, Out : "OFF"		0.7	mA	1	
Is2	Supply current 2	Pin VS	Vs = 16V, ΔVILK = -15mV, Out : "ON"		1.2	mA	1	
VLKT	Trip voltage	Pin ILK and VB	Vs = 16V, VLKT : 60Hz Test circuit 3		4	9	mVrms	
IMM+	Sink current	Pin MM	Vs = 16V, ΔVILK = 0mV, VMM = 0.8V	25	170	370	μA	4
IMM-	Source current	Pin MM	Vs = 16V, ΔVILK = -15mV, VMM = 0.8V	25	-110	-250	μA	4
tMM	Detect inhibit time	Pin MM	Vs = 16V		1.7	4	ms	10
Iou+	Sink current	Pin OUT	Vs = 16V, ΔVILK = 0mV, VOUT = 0.2V		150		μA	5
Iou-	Source current	Pin OUT	Vs = 16V, ΔVILK = -15mV VOUT = 0.8V	-20	-200		μA	5
				25	-100			
				80	-70			
tOUT	Output pulse width	Pin OUT	Vs = 16V		25	100	ms	10
VSM	Maximum current voltage	Pin VS	Is = 3.5mA	25	20	26	V	6
Is3	Supply current 3	Pin VS	Vs = 12V, VILK = 0mV VIBL = 0V, OUT : "OFF" Test circuit 2			1	mA	
Is4	Supply current 4	Pin VS	Vs = 12V, VILK = -15mV VIBL = 12V, OUT : "ON" Test circuit 2			1.4	mA	
VBLT	Trip voltage	Pin IBL	Vs = 16V		3.6	4.1	V	7
IIBL	Input current	Pin IBL	Vs = 16V, VIBL = 4.5V Test circuit 7	25		0.8	μA	
IWF+	Sink current	Pin WF	Vs = 16V, VIBL = 4.5V, VWF = 0.5V	25	1		mA	8
IWF-	Source current	Pin WF	Vs = 16V, VIBL = 0V, VWF = 0.5V	25	-22	-30	μA	8
tWF	Recovery time	Pin WF	Vs = 16V		35	70	ms	11
ITD+	Sink current	Pin TD	Vs = 16V, VIBL = 0V, VTD = 0.5V	25	1		mA	9
ITD-	Source current	Pin TD	Vs = 16V, VIBL = 4.5V, VTD = 0.5V	25	-22	-30	μA	9
tDT	Delay time	Pin TD	Vs = 16V		200	420	ms	12

APPLICATION EXAMPLE

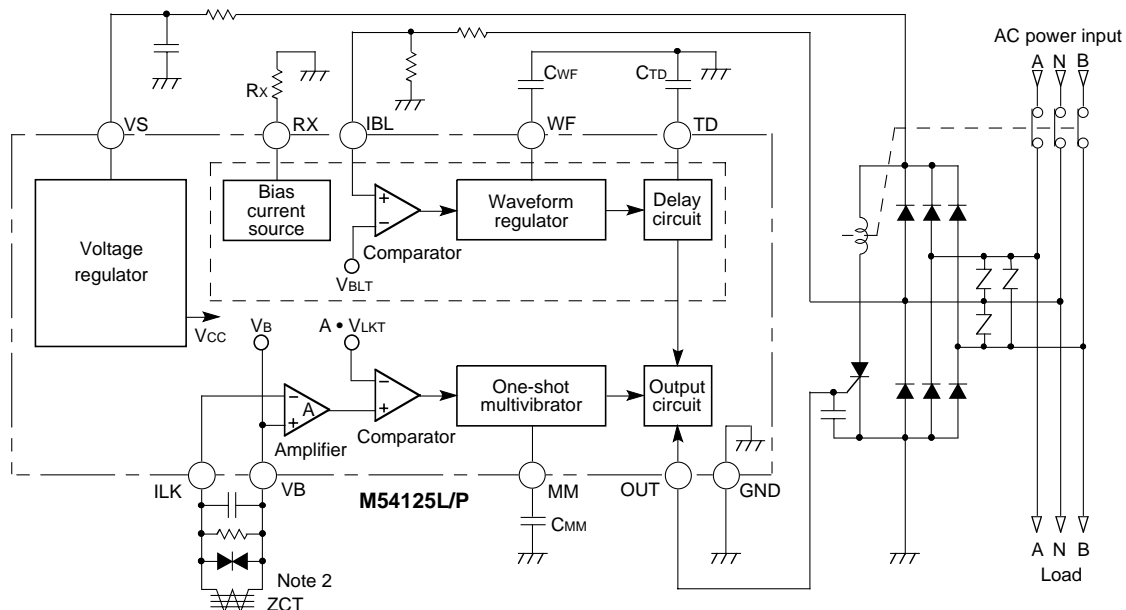

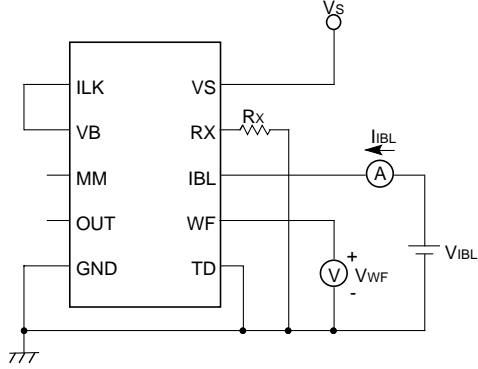
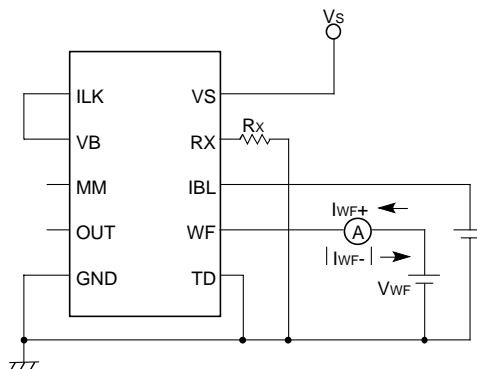
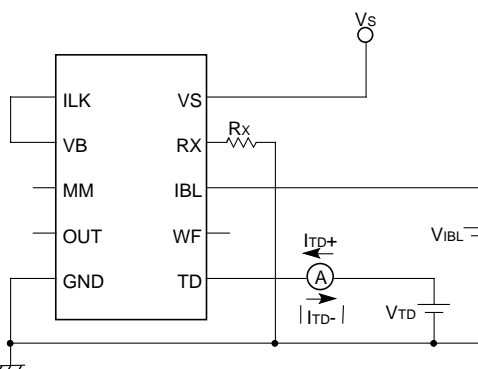
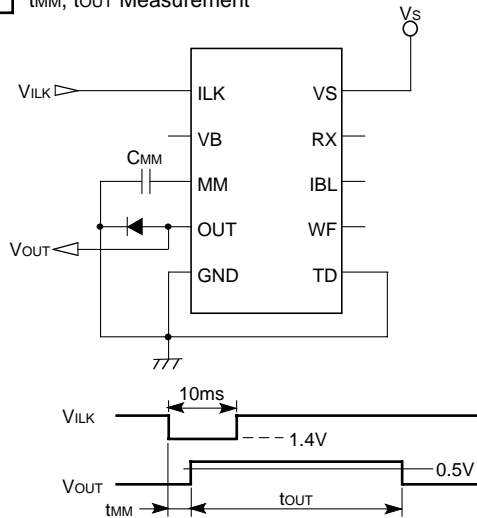
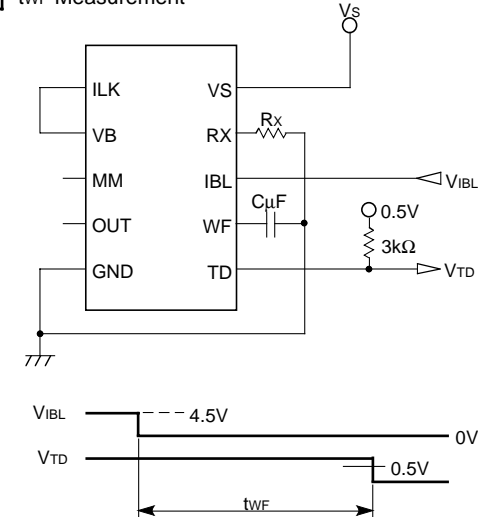
<p>7 VBLT, IBL Measurement</p>  <p>*: VBLT is the value of VIBL when VF = 0.5V.</p>	<p>8 IWF+, IWF- Measurement</p> 
<p>9 ITD+, ITD- Measurement</p> 	<p>10 tMM, tOUT Measurement</p> 
<p>11 twf Measurement</p> 	<p>12 tTD Measurement</p> 