

**DESCRIPTION**

The 54410P is a TTL integrated circuit semiconductor used for controlling the function keys on tape decks.

**FEATURES**

- Non-locking function keys can be used
- No need to prevent bounce
- Built-in pull-up resistors for input pins
- STOP mode set when power is switched on
- Wired-AND connection and transistor drive possible for output

**APPLICATION**

Tape decks, cassette recorders and VTRs

**FUNCTION**

The 54410P is configured so that the set and reset pins of the five R-S flip-flops serve as the input pins, and the desired tape mode is controlled by setting these input pins momentarily to low. Non-locking function keys can be used and there is no need to prevent bounce.

The input pins contain pull-up resistors to achieve a high noise margin even under open conditions.

The outputs have a resistive load, and both wired-AND connection and transistor drive are possible. When the power is switched on, the automatic reset function is energized and the mode is set to STOP.

**PIN CONFIGURATION (TOP VIEW)**

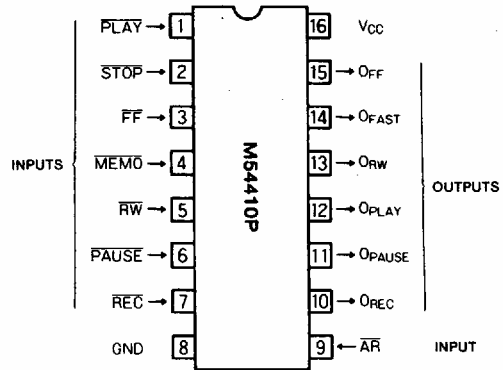

Outline 16P4

**BLOCK DIAGRAM**

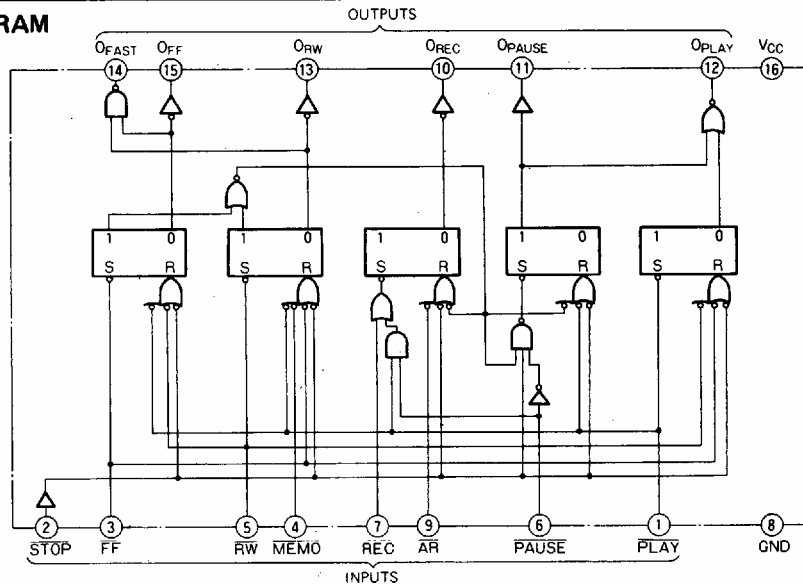

KEY CONTROLLER FOR TAPE DECK

INPUT/OUTPUT EQUIVALENT CIRCUITS

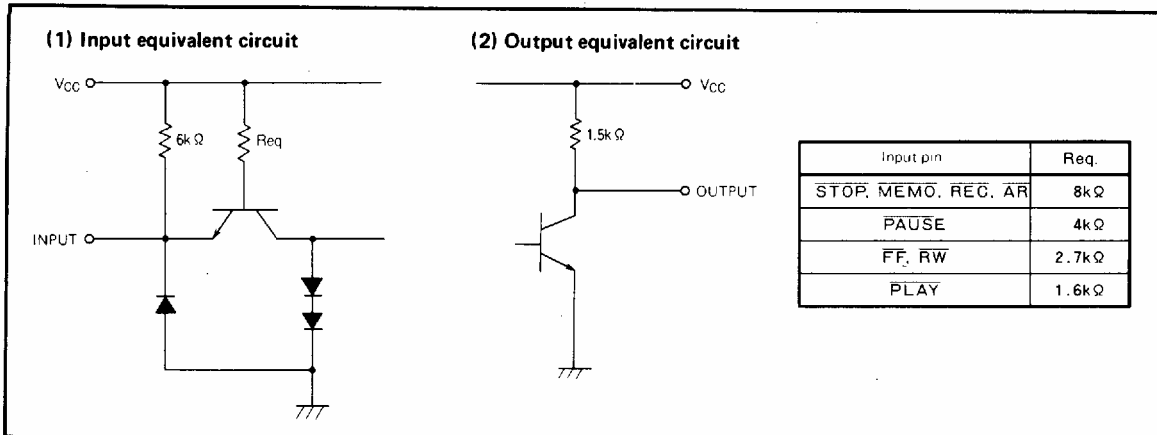

PIN NAMES AND FUNCTIONS

Pin name	Function	
Function input pin	STOP	Stop command input pin
	FF	FF (Fast forward) command input pin
	RW	RW (Rewind) command input pin
	REC	REC (Record) command input pin, effective only when it is set to low together with PLAY
	PAUSE	Pause command input pin
	PLAY	Play start command input pin, when set to low together with REC, recording starts
Control input pin	MEMO	Memory input pin
	AR	Recording prevention input pin
Output pin	OFAST	Output pin that goes high in the FF or RW mode
	OFF	Output pin that goes high in the FF mode
	ORW	Output pin that goes high in the RW mode
	OREC	Output pin that goes high in the REC/PLAY or REC/PAUSE mode
	OPAUSE	Output pin that goes high in the PAUSE mode
	OPLAY	Output pin that goes high in the PLAY mode

OPERATIONS WITH EACH INPUT

Input signal	OFAST	OFF	ORW	OREC	OPAUSE	OPLAY	Output mode
STOP	L	L	L	L	L	L	STOP mode
FF	H	H	L	L	L	L	FF mode
RW	H	L	H	L	L	L	RW mode
PLAY	L	L	L	L	L	H	PLAY mode
PAUSE	L	L	L	L	H	L	PAUSE mode
REC/PLAY	L	L	L	H	L	H	REC/PLAY mode
REC/PAUSE	L	L	L	H	H	L	REC/PAUSE mode

- Note 1. Input signal operates at the fall.
2. The output maintains the output state until the next input signal arrives.
3. REC/PLAY indicates that REC and PLAY are simultaneously set to low.
4. REC/PAUSE indicates that REC and PAUSE are simultaneously set to low.
5. MEMO and AR are control input pins, and when MEMO is low, the ORW output is not set to high.  
Should the MEMO = be low when the ORW output is high, the ORW output is set to low.  
When AR is low, the OREC output is not set to high.  
Should the AR be low when the OREC output is high, the OREC output is set to low.

KEY CONTROLLER FOR TAPE DECK

OPERATIONS FROM OUTPOUT MODES

Present output mode	STOP	FF	RW	PLAY	PAUSE	REC/PLAY	REC/PAUSE	MEMO	AR
STOP mode	<input type="checkbox"/>	FF mode	RW mode	PLAY mode	PAUSE mode	REC/PLAY mode	REC/PAUSE mode	STOP mode	STOP mode
FF mode	STOP mode	<input type="checkbox"/>	RW mode	PLAY mode	FF mode	REC/PLAY mode	FF mode	FF mode	FF mode
RW mode	STOP mode	FF mode	<input type="checkbox"/>	PLAY mode	RW mode	REC/PLAY mode	RW mode	STOP mode	RW mode
PLAY mode	STOP mode	FF mode	RW mode	<input type="checkbox"/>	PAUSE mode	REC/PLAY mode	REC/PAUSE mode	PLAY mode	PLAY mode
PAUSE mode	STOP mode	FF mode	RW mode	PLAY mode	<input type="checkbox"/>	REC/PLAY mode	REC/PAUSE mode	PAUSE mode	PAUSE mode
REC/PLAY mode	STOP mode	FF mode	RW mode	REC/PLAY mode	REC/PAUSE mode	<input type="checkbox"/>	REC/PAUSE mode	REC/PLAY mode	PLAY mode
REC/PAUSE mode	STOP mode	FF mode	RW mode	REC/PLAY mode	REC/PAUSE mode	REC/PLAY mode	<input type="checkbox"/>	REC/PAUSE mode	PAUSE mode

When an input signal enters in the present output mode, the output mode given in the above table is established.

: This indicates that the output mode does not change.

INPUT MULTIPLE PUSH OPERATIONS

A input signal	B input signal	Output mode
STOP	FF, RW, REC, PAUSE, PLAY	STOP mode
FF	RW	STOP mode
	REC, PAUSE	FF mode
	PLAY	STOP mode
RW	REC, PAUSE	RW mode
	PLAY	STOP mode

A input signal	B input signal	Output mode
REC	PAUSE	REC/PAUSE mode
	PLAY	REC/PLAY mode
	PAUSE & PLAY	REC/PAUSE mode
PAUSE	PLAY	PAUSE mode

The output modes in the above table are established with multiple input signals A and B. When the multiple push input signal operation has been released, the input signal released last is made effective and the corresponding output mode is established.

(This does not apply to the REC/PAUSE and REC/PLAY modes.)

OUTPUT MODE WITH POWER SWITCH-ON

When the power is switched on, all the outputs are set to low and the STOP mode is established.

ABSOLUTE MAXIMUM RATINGS (Ta = -20 ~ +75°C, unless otherwise noted)

Symbol	Parameter	Condition	Ratings	Unit
V <sub>CC</sub>	Supply voltage		7	V
V <sub>i</sub>	Input voltage		V <sub>CC</sub>	V
V <sub>o</sub>	Output voltage	When output is "high"	V <sub>CC</sub>	V
P <sub>d</sub>	Power dissipation		500	mW
T <sub>opr</sub>	Operating temperature		-20 ~ +75	°C
T <sub>stg</sub>	Storage temperature		-55 ~ +125	°C

RECOMMENDED OPERATING CONDITIONS (Ta = -20 ~ +75°C, unless otherwise noted)

Symbol	Parameter	Limits			Unit
		Min	Typ	Max	
V <sub>CC</sub>	Supply voltage	4.5	5	5.5	V
I <sub>OL</sub>	Low-level output current	V <sub>CC</sub> = 5V ± 10%		10	mA
		V <sub>CC</sub> = 5V ± 20%		7.6	
I <sub>OH</sub>	High-level output current	V <sub>CC</sub> = 5V ± 10%		-1.6	mA
		V <sub>CC</sub> = 5V ± 20%		-1.4	



KEY CONTROLLER FOR TAPE DECK

ELECTRICAL CHARACTERISTICS (Ta = -20 ~ +75°C, unless otherwise noted)

Symbol	Parameter	Test conditions	Limits			Unit
			Min	T <sub>yo</sub> *	Max	
V <sub>IH</sub>	High-level input voltage		2			V
V <sub>IL</sub>	Low-level input voltage				0.8	V
V <sub>IC</sub>	Input clamp voltage	V <sub>CC</sub> = 4.5V, I <sub>IC</sub> = -12mA		-1.0	-1.5	V
V <sub>I(open)</sub>	Input open voltage	V <sub>CC</sub> = 4.5V, I <sub>I</sub> = 0mA	3.2			V
V <sub>OH</sub>	High-level output voltage	V <sub>CC</sub> = 4.5V, V <sub>IH</sub> = 2V, V <sub>IL</sub> = 0.8V I <sub>OH</sub> = -0.4mA	2.9	4.3		V
V <sub>OL</sub>	Low-level output voltage	V <sub>CC</sub> = 4.5V, V <sub>IH</sub> = 2V, V <sub>IL</sub> = 0.8V I <sub>OL</sub> = 10mA		0.25	0.4	V
I <sub>IL</sub>	Low-level input current	STOP, MEMO, REC, AR input pins		-1.4	-2.3	mA
		PAUSE input pin	V <sub>CC</sub> = 5.5V, V <sub>I</sub> = 0V	-1.9	-3.3	
		FF, RW input pins		-2.4	-4.2	
		PLAY input pin		-3.5	-6.0	
I <sub>OX</sub>	High-level output current	V <sub>CC</sub> = 4.5V, V <sub>O</sub> = 0.9V	-1.6	-2.6		mA
I <sub>CC</sub>	Circuit current	V <sub>CC</sub> = 5.5V		54	90	mA

\* : Typical values are at T<sub>a</sub> = 25°C.

APPLICATION EXAMPLE

