

M54535P

7-UNIT 150mA TRANSISTOR ARRAY WITH CLAMP DIODE AND STROBE

DESCRIPTION

The M54535P, 7-channel sink driver, consists of 14 NPN transistors connected to form high current gain driver pairs.

FEATURES

- Output sink current to 150mA
- Strobe input control
- PMOS Compatible input
- Wide operating temperature range ($T_a = -20 \sim +75^\circ\text{C}$)

APPLICATIONS

- Relay and printer driver
- LED or incandescent display digit driver
- Interfacing for standard MOS/BIPOLAR logics

FUNCTION

The M54535P uses a predriver stage. Each input has a diode and $20\text{k}\Omega$ resistor in series to allow a negative voltage input. All inputs can be controlled simultaneously by a strobe input at pin 18. Each output has an integral diode for inductive load transient suppression.

The cathodes of the diodes and the power supply of the predrivers are connected to pin 10. All emitters and the substrate are connected together to pin 9.

The outputs are capable of sinking 150mA and will withstand 10V in the OFF state.

PIN CONFIGURATION (TOP VIEW)

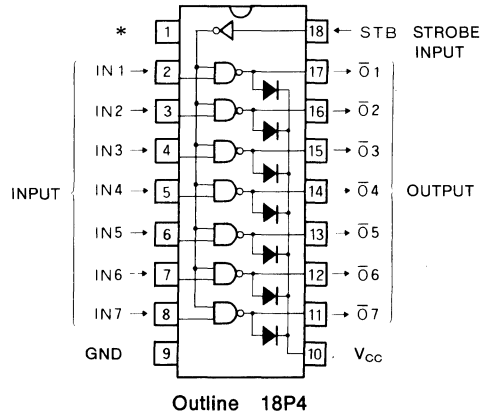

CIRCUIT SCHEMATIC

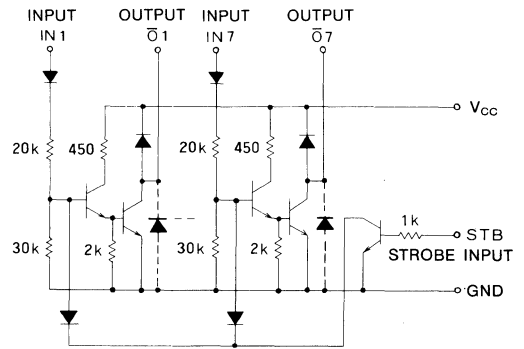

FUNCTIONAL TABLE

IN	STB	OUT
L	L	H
H	L	L
L	H	H
H	H	H

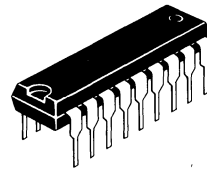

18-pin molded plastic DIL

ABSOLUTE MAXIMUM RATINGS ($T_a = -20 \sim +75^\circ\text{C}$, unless otherwise noted)

Symbol	Parameter	Conditions	Limits	Unit
V_{CC}	Supply voltage		10	V
V_O	Output voltage	Transistor OFF	V_{CC}	V
I_C	Collector current	Transistor ON	150	mA
V_i	Input voltage		-25, 20	V
$V_{I(STB)}$	Strobe input voltage		20	V
$V_{R(D)}$	Clamp diode reverse voltage		10	V
$I_{F(D)}$	Clamp diode forward current		150	mA
P_d	Power dissipation	$T_a = 25^\circ\text{C}$	1.47	W
T_{opr}	Operating ambient temperature range		-20 ~ +75	$^\circ\text{C}$
T_{stg}	Storage temperature range		-55 ~ +125	$^\circ\text{C}$

7-UNIT 150mA TRANSISTOR ARRAY WITH CLAMP DIODE AND STROBE

RECOMMENDED OPERATIONAL CONDITIONS ($T_a = -20 \sim +75^\circ\text{C}$, unless otherwise noted)

Symbol	Parameter		Limits			Unit
			Min	Typ	Max	
V_{CC}	Supply voltage		3		8	V
V_O	Output voltage	$V_{CC}=10\text{V}$			10	V
I_C	Collector current per channel	Percent duty cycle less than 65%			150	mA
V_{IH}	"H" Input voltage	$I_C=100\text{mA}$	7			V
V_{IL}	"L" Input voltage				0.8	V
$V_{IH(STB)}$	"H" Input voltage (strobe input)	$V_I=12\text{V}$	1.3			V
		$V_I=20\text{V}$	2.4			
$V_{IL(STB)}$	"L" Input voltage (strobe input)				0.2	V

ELECTRICAL CHARACTERISTICS ($T_a = -20 \sim +75^\circ\text{C}$, unless otherwise noted)

Symbol	Parameter	Test conditions	Limits			Unit
			Min	Typ*	Max	
$V_{CE(sat)}$	Output saturation voltage	$V_{I(STB)}=0.2\text{V}$ $V_{CC}=6\text{V}, I_I=300\mu\text{A}, I_C=100\text{mA}$			0.3	V
		$V_I=7\text{V}$ $V_{I(STB)}=0.2\text{V}$	$V_{CC}=3\text{V}$ $I_C=100\text{mA}$		0.3	V
		$V_{I(STB)}=0.2\text{V}$	$V_{CC}=8\text{V}$ $I_C=150\text{mA}$		0.5	V
$I_{O(leak)}$	Output leak current	$V_{CC}=8\text{V}, V_I=0.8\text{V}, V_O=8\text{V}$ $V_{I(STB)}=0.2\text{V}$			50	μA
I_I	Input current	$V_{CC}=8\text{V}, V_I=12\text{V}$ $V_{I(STB)}=0.2\text{V}$			1	mA
I_R	Input leakage current	$V_{CC}=8\text{V}, V_I=-25\text{V}$			-20	μA
$I_{I(STB)}$	Strobe input current	$V_I=12\text{V}, V_{I(STB)}=2.4\text{V}$			3	mA
$V_{F(D)}$	Clamp diode forward voltage	$I_{F(D)}=150\text{mA}$			2.1	V
$V_{R(D)}$	Clamp diode reverse voltage	$I_{R(D)}=100\mu\text{A}$	10			V
I_{CC}	Supply current	$V_{CC}=8\text{V}, V_I=12\text{V}$ all input $V_{I(STB)}=0.2\text{V}$		120	200	mA
h_{FE}	DC forward current gain	$V_{CE}=4\text{V}, V_{CC}=6\text{V}, I_C=150\text{mA}, T_a=25^\circ\text{C}$	700			

* : The typical value is at $T_a=25^\circ\text{C}$.

7-UNIT 150mA TRANSISTOR ARRAY WITH CLAMP DIODE AND STROBE

TYPICAL CHARACTERISTICS

ALLOWABLE AVERAGE POWER DISSIPATION

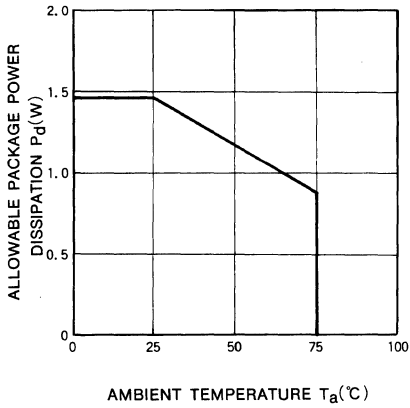

ALLOWABLE COLLECTOR CURRENT AS A FUNCTION OF DUTY CYCLE

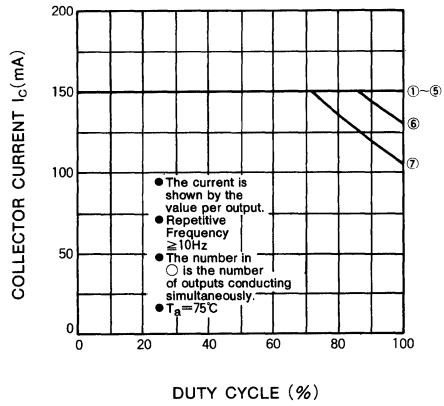

OUTPUT CURRENT CHARACTERISTICS

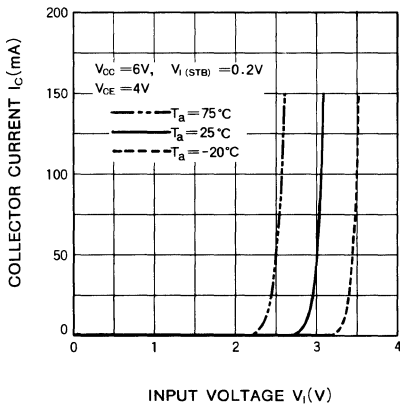

DC CURRENT GAIN CHARACTERISTICS

