

M54537P

7-UNIT 350mA TRANSISTOR ARRAY

DESCRIPTION

The M54537P, 7-channel sink driver, consists of 14 NPN transistors connected to form high current gain driver pairs.

FEATURES

- Output breakdown voltage to 20V
- High output sink current to 250mA
- PMOS Compatible input
- Low output saturation voltage
- Wide operating temperature range ($T_a = -20 \sim +75^\circ\text{C}$)

APPLICATIONS

- Relay and printer driver
- LED or incandescent display digit driver
- Interfacing for standard MOS/BIPOLAR logics

FUNCTION

The M54537P uses a predriver stage with $2\text{k}\Omega$ series input resistor. The power supply of the predrivers is connected to pin 9. All emitters and the substrate are connected together to pin 8. The outputs are capable of sinking 250mA and will withstand 20V in the OFF state.

PIN CONFIGURATION (TOP VIEW)

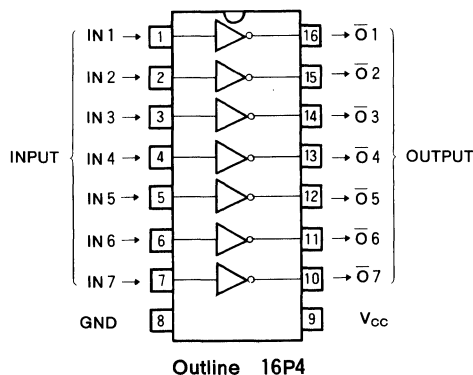

CIRCUIT SCHEMATIC

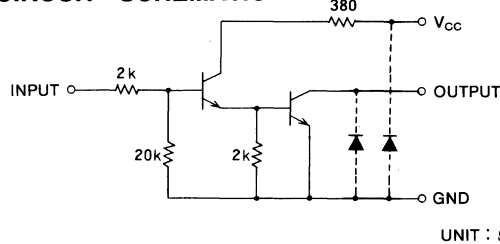

RECOMMENDED OPERATIONAL CONDITIONS ($T_a = -25 \sim +75^\circ\text{C}$, unless otherwise noted)

Symbol	Parameter	Limits			Unit
		Min	Typ	Max	
V_{CC}	Supply voltage	3		8	V
V_O	Output voltage			20	V
I_C	Collector current per channel	$V_{CC} = 6.5\text{V}$ Percent duty cycle less than 40%		250	mA
		$V_{CC} = 6.5\text{V}$ Percent duty cycle less than 65%		150	mA
V_{IH}	"H" Input voltage	$I_C = 250\text{mA}$	3		V
V_{IL}	"L" Input voltage	$I_{O(LEAK)} = 50\mu\text{A}$		0.3	V

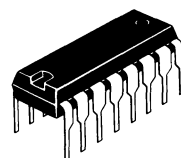

16-pin molded plastic DIL

ABSOLUTE MAXIMUM RATINGS ($T_a = -25 \sim +75^\circ\text{C}$, unless otherwise noted)

Symbol	Parameter	Conditions	Limits	Unit
V_{CC}	Supply voltage		10	V
V_{CEO}	Output sustaining voltage	Transistor OFF	20	V
I_C	Collector current	Transistor ON	350	mA
V_I	Input voltage		10	V
P_d	Power dissipation	$T_a = 25^\circ\text{C}$	1.47	W
T_{opr}	Operating ambient temperature range		$-20 \sim +75$	$^\circ\text{C}$
T_{stg}	Storage temperature range		$-55 \sim +125$	$^\circ\text{C}$

7-UNIT 350mA TRANSISTOR ARRAY

ELECTRICAL CHARACTERISTICS ($T_a = -25 \sim +75^\circ\text{C}$, unless otherwise noted)

Symbol	Parameter	Test conditions	Limits			Unit
			Min	Typ	Max	
$V_{(BR)CEO}$	Output sustaining voltage	$V_{CC}=8\text{V}, I_{CEO}=100\mu\text{A}$	20			V
$V_{CE(sat)}$	Output saturation voltage	$V_I=3\text{V}$			0.5	V
			$V_{CC}=6.5\text{V}, I_C=250\text{mA}$		0.35	V
I_i	Input current	$V_{CC}=8\text{V}, V_I=3.2\text{V}$			1.5	mA
		$V_{CC}=8\text{V}, V_I=10\text{V}$			7.3	mA
I_{CC}	Supply current	$V_{CC}=8\text{V}, V_I=3.2\text{V}$			190	mA
h_{FE}	DC forward current gain	$V_{CE}=4\text{V}, V_{CC}=6.5\text{V}, I_C=250\text{mA}, T_a=25^\circ\text{C}$	1000			

TYPICAL CHARACTERISTICS

ALLOWABLE AVERAGE

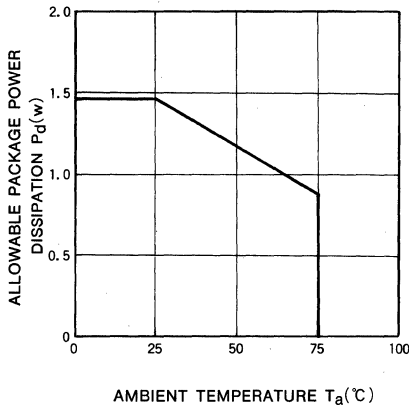

OUTPUT CURRENT CHARACTERISTICS

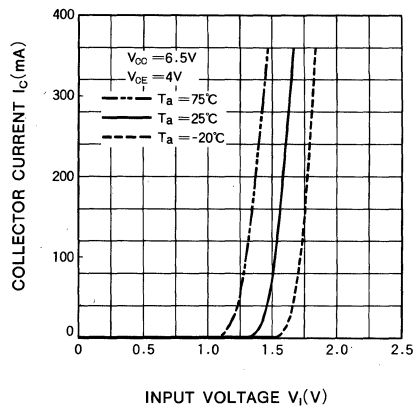

ALLOWABLE COLLECTOR CURRENT AS A FUNCTION OF DUTY CYCLE

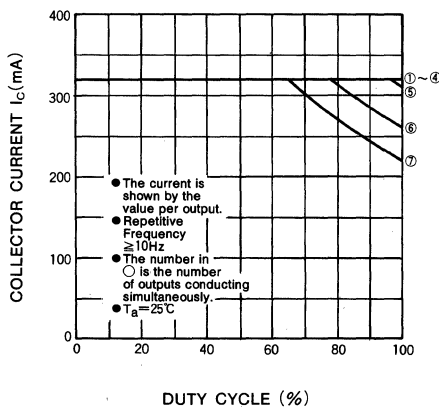

ALLOWABLE COLLECTOR CURRENT AS A FUNCTION OF DUTY CYCLE

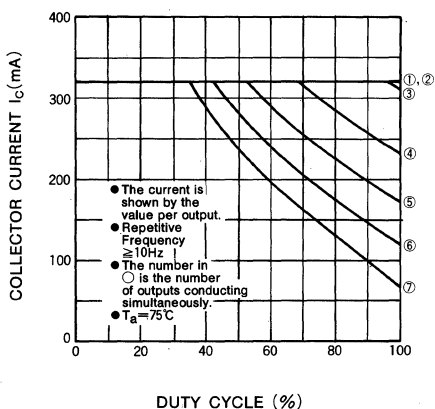

DC CURRENT GAIN CHARACTERISTICS

