

**DESCRIPTION**

The M54617P is an integrated circuit for two-wire system LAN transceivers in compliance with J1850.

It has a built-in function detecting bus-line abnormality, and allows ERR signal to turn to "L" in case of abnormality. In addition, the selector permits the output of normal bus signal.

Turning the standby signal to "L" provides a low current dissipation status, when both BUS(+) and BUS(-) of the driver are turned OFF. Further, inputting "H" level to ERR pin when in the standby mode allows error output to be reset.

**FEATURES**

- Compliance with SAE J1850 standards
- Built-in function detecting bus-line abnormality

**APPLICATION**

LAN transceivers in general and other communication transceivers (The M59330P having the same function is available as a vehicle-loaded LAN transceiver).

**PIN CONFIGURATION (TOP VIEW)**

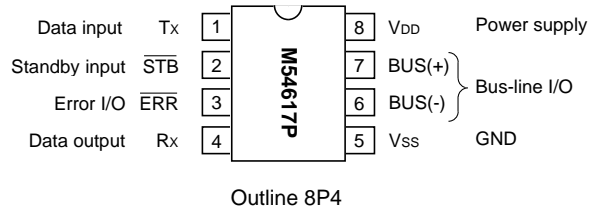

**BLOCK DIAGRAM**

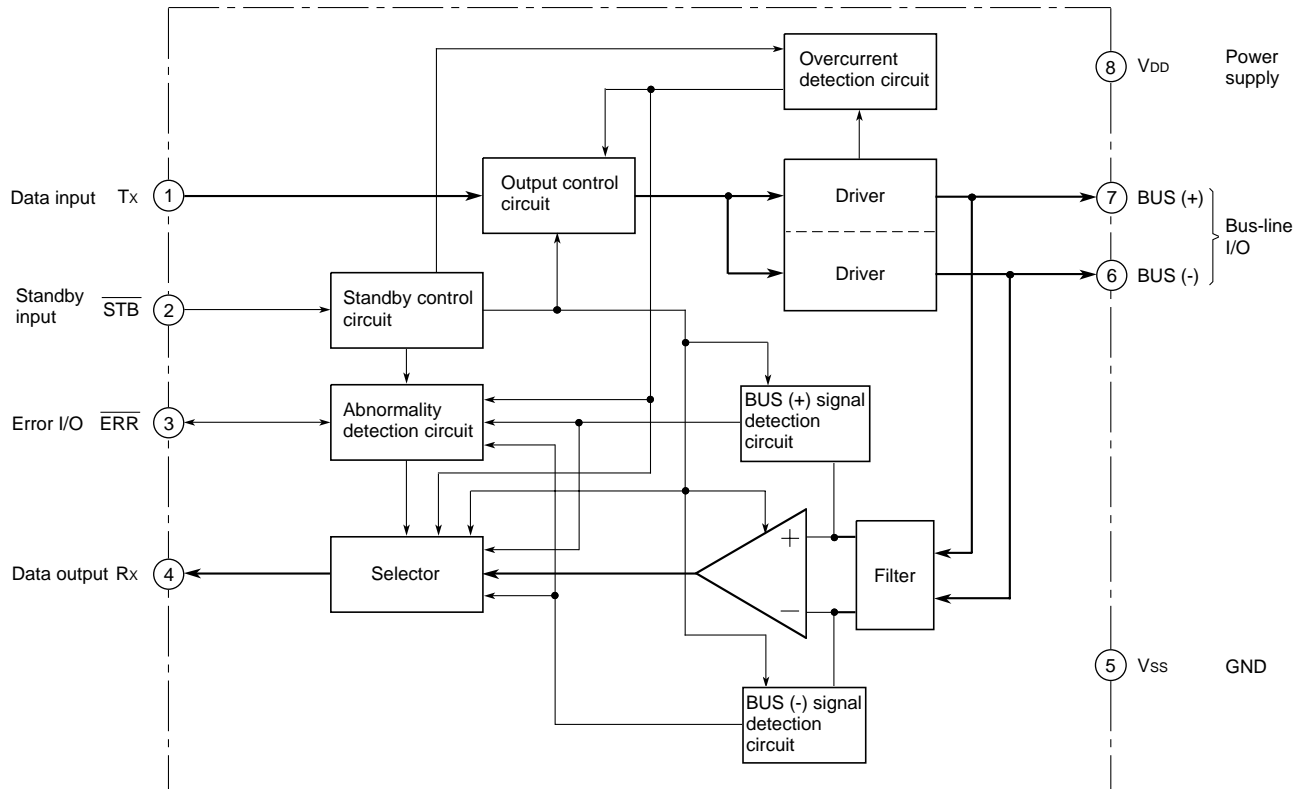

**FUNCTION****Pin function**

Pin No.	Pin name	I/O	Function
①	Tx	Input	Data signal input pin
②	$\overline{\text{STB}}$	Input	Standby signal input pin L: standby mode, H: normal operation
③	$\overline{\text{ERR}}$	I/O	Error signal output pin and error reset input pin "L" level output when abnormal transmission route is detected Error reset with "H" level input when in the standby mode
④	Rx	Output	Signal output pin from transmission route
⑤	Vss	Input	Grounding pin
⑥	BUS(-)	I/O	Signal output pin to transmission route and signal input pin from transmission route (negative logic)
⑦	BUS(+)	I/O	Signal output pin to transmission route and signal input pin from transmission route (positive logic)
⑧	VDD	Input	Power supply pin

**ABNORMALITY DETECTION OF TRANSMISSION ROUTE AND COMMUNICATION FUNCTION**

The M54617P uses its driver overcurrent detection function and transmission signal logic abnormality function to perform the abnormality detection of the transmission route, and outputs error signal ( $\overline{\text{ERR}}$ (3 pin) = "L").

In addition, switching the signal that is output to Rx pin (pin 4) according to the abnormality occurrence status permits communication after abnormality has occurred.

**(1) Overcurrent detection**

BUS(+) pin (pin 7) and BUS(-) pin (pin 6) drivers of M54617P are equipped with an overcurrent detection circuit. When overcurrent flows to a driver, the driver is turned OFF to output error signal ( $\overline{\text{ERR}}$  (pin 3) = "L"). Once an overcurrent is detected, the driver maintains the OFF status until the error is reset.

In addition, each driver of BUS(+) pin (pin 7) and BUS(-) pin (pin 6) is independent, and both may be turned OFF depending upon the abnormality occurrence status.

A built-in filter for the prevention of malfunction due to overcurrent when the driver is turned ON does not permit the detection of the overcurrent status for a short time (several hundred ns). Detection current is set to about 180mA.

**(2) Logic abnormality detection**

The M54617P transmission signals operate in the opposite phase to each other, and abnormal transmission route is detected by comparing these signals. Upon comparing respective signals after a set time on the basis of the edge of transmission routes BUS(+) and BUS(-), any disagreement is regarded as abnormal transmission, and error signal ( $\overline{\text{ERR}}$  (pin 3) = "L") is output. In order to be well timed with that edge as a new standard, abnormality is detected when signal disagreement continues for more than a set time. Setting time is set to about 4.2 $\mu$ s.

Logic abnormality detection does not cope with more than one error mode.

Detection of logic abnormality alone does not allow the driver to be turned OFF. Abnormality detection allows the driver to be turned OFF only when overcurrent is detected.

**(3) Communication function**

The M54617P ordinarily outputs the differential signals of BUS(+) (pin 7) and BUS(-) (pin 6). When abnormality is detected, signals to be output to Rx pin (pin 4) are switched according to the status.

When overcurrent is detected, the driver or the transmission route in which overcurrent is detected is considered abnormal, and error signal is output, and concurrently the signal of another transmission route is output to Rx output (pin 4).

As described in the above section (1), both drivers are turned OFF in some cases. In these cases, Rx output (pin 4) is fixed to "L".

When logic abnormality is detected, error signal ( $\overline{\text{ERR}}$  (pin 3) = "L") is output, and concurrently Rx output (pin 4) is turned to "L". After error signal is output, the transmission route in which the edge of transmission signals is detected is considered normal, and such signal is output to Rx output (pin 4).

In switching operation of error signal output and Rx output the priority is given to overcurrent detection over logic abnormality detection.

**Table 1. Abnormality mode and abnormality detection function**

	Abnormality mode	Error output	Communication after abnormality is detected	Abnormality detection method	
1	BUS(+)	GND short	Yes	Yes	(2)
2		V <sub>DD</sub> short	Yes	Yes	(1), (2)
3		Open	Yes	Yes	(2)
4	BUS(-)	GND short	Yes	Yes	(1), (2)
5		V <sub>DD</sub> short	Yes	Yes	(2)
6		Open	Yes	Yes	(2)
7	BUS(+) and BUS(-) short	Yes	No	(1)	

**ERROR RESET**

Error output of the M54617P can be reset by turning to the standby mode ( $\overline{\text{STB}}$  pin (pin 2) = "L"), followed by inputting "H" level to  $\overline{\text{ERR}}$  pin (pin 3). In this case, all operations are cleared that relate to abnormality detection including overcurrent detection and switching of Rx output.

**STANDBY MODE**

The M54617P can be set to the low current dissipation mode by turning  $\overline{\text{STB}}$  pin (pin 2) to level "L".

Standby mode does not allow the driver and overcurrent detection function to be operated, but logic abnormality detection function operates, which permits detection other than abnormality relating to overcurrent detection. However, it provides error signal output only, but no switching of Rx output signal.

Rx output when in the standby mode outputs the logic sum of BUS(+) and  $\overline{\text{BUS}}(-)$  signals.

**I/O EQUIVALENT CIRCUIT**

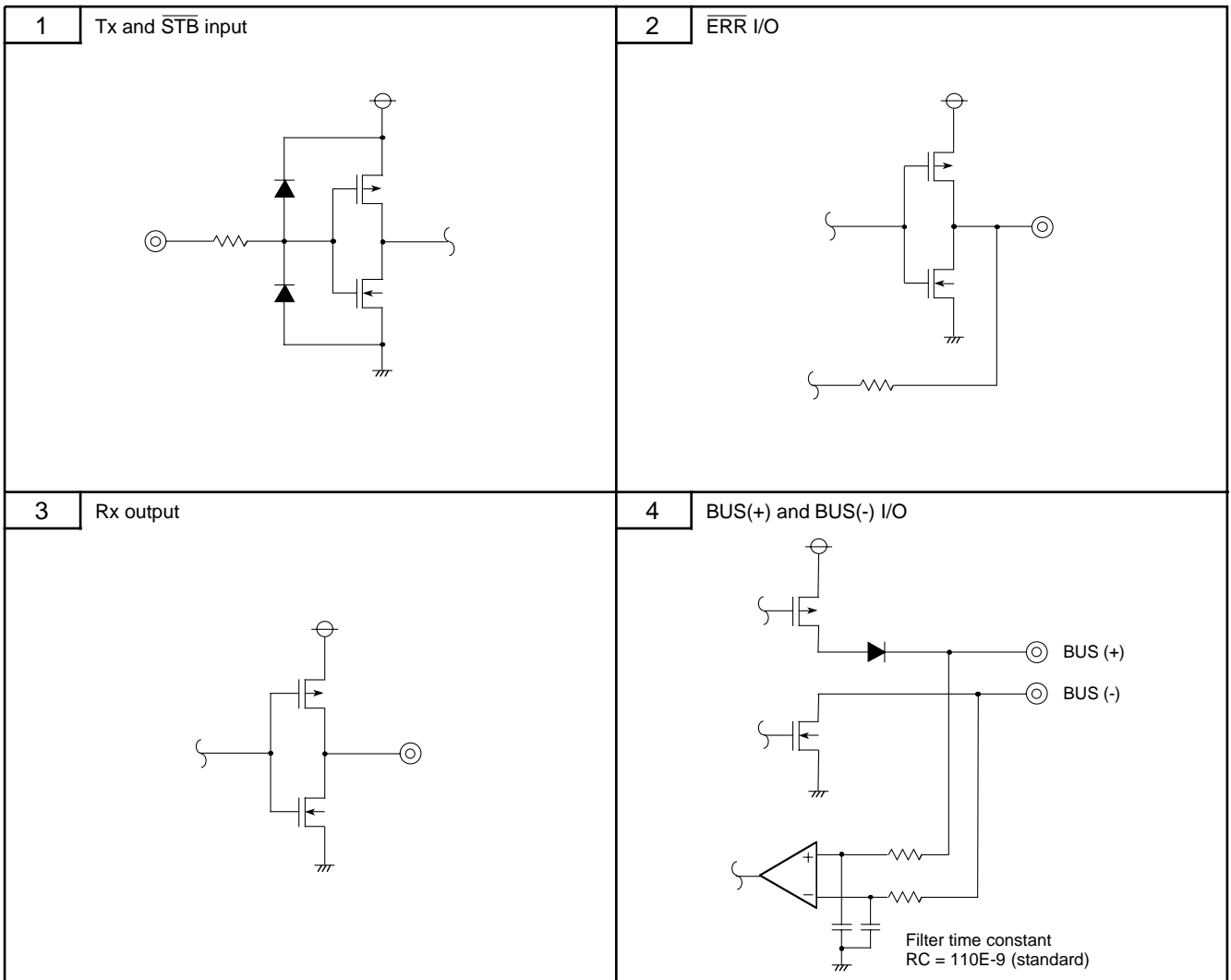

**ABSOLUTE MAXIMUM RATINGS** (Ta = 25°C unless otherwise noted)

Symbol	Parameter	Conditions	Ratings			Unit
			Min.	Typ.	Max.	
V <sub>DD</sub>	Supply voltage		-0.3		6.5	V
V <sub>I</sub>	Input voltage		-0.3		V <sub>DD</sub> +0.3	V
V <sub>O</sub>	Output voltage		-0.3		V <sub>DD</sub> +0.3	V
I <sub>O</sub>	Driver output current	BUS(+)			50	mA
		BUS(-)	-50			
P <sub>max</sub>	Allowable power dissipation				200	mW
T <sub>stg</sub>	Storage temperature		-50		125	°C

Note: All voltages shall be based on V<sub>SS</sub> pin of the circuit, the max. and min. values be indicated in the absolute values, and the directions of the current be positive when flowing into the circuit and negative ("-" symbol) when flowing out of the circuit.

**RECOMMENDED OPERATING CONDITIONS** (Ta = 25°C unless otherwise noted)

Symbol	Parameter	Conditions	Limits			Unit
			Min.	Typ.	Max.	
V <sub>DD</sub>	Supply voltage		4.75		5.25	V
R <sub>BUS</sub>	BUS resistance	Transmission rate = 41.6Kbps	105			Ω
		Transmission rate = 125Kbps	105			
C <sub>BUS</sub>	BUS capacitance	Transmission rate = 41.6Kbps, R <sub>BUS</sub> = 378Ω			10000	pF
		Transmission rate = 125Kbps, R <sub>BUS</sub> = 378Ω			3000	
T <sub>opr</sub>	Operating temperature		-20		75	°C

**ELECTRICAL CHARACTERISTICS** (Ta = 25°C and VDD = 5.0V when in normal operation unless otherwise noted)

Symbol	Parameter	Conditions	Limits			Unit
			Min.	Typ.	Max.	
I <sub>DD1</sub>	Supply current 1	R <sub>BUS</sub> = 105Ω, T <sub>X</sub> = "L", ST <sub>B</sub> = "H"			5.0	mA
I <sub>DD2</sub>	Supply current 2	R <sub>BUS</sub> = 105Ω, T <sub>X</sub> = "H", ST <sub>B</sub> = "H"			55	mA
I <sub>DD3</sub>	Supply current 3	R <sub>BUS</sub> = 105Ω, T <sub>X</sub> = ST <sub>B</sub> = "H"			200	μA
V <sub>TH1</sub>	"H" input threshold voltage 1	$\overline{ERR}$	2.2		3.2	V
V <sub>TH2</sub>	"H" input threshold voltage 2	T <sub>X</sub> , ST <sub>B</sub>	2.3		3.5	V
V <sub>TL</sub>	"L" input threshold voltage	T <sub>X</sub> , ST <sub>B</sub>	1.6		2.8	V
V <sub>HYSL</sub>	Hysteresis width	T <sub>X</sub> , ST <sub>B</sub>	0.4		1.0	V
V <sub>CIN</sub>	BUS input voltage range	BUS(+), BUS(-)	V <sub>SS</sub>		V <sub>DD</sub> -2.0	V
V <sub>HYSB</sub>	Input hysteresis width	BUS(+) and BUS(-) differential input	70		300	mV
I <sub>I<sub>PP1</sub></sub>	BUS(+) leakage current 1	When the power supply is turned OFF (V <sub>DD</sub> = 0V), BUS(+) = 0V			100	μA
I <sub>I<sub>DP1</sub></sub>	BUS(+) leakage current 2	When the power supply is turned OFF (V <sub>DD</sub> = 0V), BUS(+) = 5V			100	μA
I <sub>I<sub>PP2</sub></sub>	BUS(+) leakage current 3	When the power supply is turned ON BUS(+) = 0V	-20			μA
I <sub>I<sub>DP2</sub></sub>	BUS(+) leakage current 4	When the power supply is turned ON BUS(+) = 5V			100	μA
I <sub>I<sub>PM1</sub></sub>	BUS(-) leakage current 1	When the power supply is turned OFF (V <sub>DD</sub> = 0V), BUS(-) = 5V			100	μA
I <sub>I<sub>DM1</sub></sub>	BUS(-) leakage current 2	When the power supply is turned OFF (V <sub>DD</sub> = 0V), BUS(-) = 0V			100	μA
I <sub>I<sub>PM2</sub></sub>	BUS(-) leakage current 3	When the power supply is turned ON BUS(-) = 5V			20	μA
I <sub>I<sub>DM2</sub></sub>	BUS(-) leakage current 4	When the power supply is turned ON BUS(-) = 0V			100	μA
V <sub>DROP1</sub>	Driver and drop voltage	IBUS(+) = -50mA			1.5	V
V <sub>DROP2</sub>		IBUS(-) = +50mA			0.6	
V <sub>OH1</sub>	"H" output voltage 1	R <sub>X</sub> pin I <sub>OH</sub> = -1mA	4.5		5.0	V
V <sub>OL1</sub>	"L" output voltage 1	R <sub>X</sub> pin I <sub>OL</sub> = +1mA			0.6	V
V <sub>OH2</sub>	"H" output voltage 2	$\overline{ERR}$ pin I <sub>OH</sub> = -1mA	4.5		5.0	V
I <sub>PD</sub>	$\overline{ERR}$ pulldown current	$\overline{ERR}$ pin V <sub>OH</sub> = 3.0V		350	700	μA
C <sub>I1</sub>	Input capacitance 1	When the power supply is turned OFF (V <sub>DD</sub> = 0V)			150	pF
C <sub>I2</sub>	Input capacitance 2	When the power supply is turned ON			150	pF
V <sub>TH1</sub>	Grounding offset voltage	Between 2 nodes			0.5	V

**TIMING CHARACTERISTICS** ( $T_a = 25^\circ\text{C}$  and  $V_{DD} = 5.0\text{V}$  when in normal operation unless otherwise noted)

Symbol	Parameter	Conditions	Limits			Unit
			Min.	Typ.	Max.	
$T_{dTBf}$	$\text{TX} \rightarrow \text{BUS}$ output delay time	CBUS = 10000pF, RBUS = 378 $\Omega$ Transmission rate = 41.6Kbps		0.25		$\mu\text{s}$
$T_{dTRr}$	$\text{TX} \rightarrow \text{RX}$ rise delay time	CBUS = 10000pF, RBUS = 378 $\Omega$ Transmission rate = 41.6Kbps		0.6		$\mu\text{s}$
$T_{dTRf}$	$\text{TX} \rightarrow \text{RX}$ fall delay time	CBUS = 10000pF, RBUS = 378 $\Omega$ Transmission rate = 41.6Kbps		3.0		$\mu\text{s}$
$T_{dBRr}$	BUS $\rightarrow$ RX rise delay time	Transmission rate = 41.6Kbps		0.35		$\mu\text{s}$
$T_{dBRf}$	BUS $\rightarrow$ RX fall delay time	Transmission rate = 41.6Kbps		0.33		$\mu\text{s}$
$T_{wS}$	$\overline{\text{STB}}$ input minimum pulse width	Standby mode	3.0			$\mu\text{s}$
$T_{sS}$	$\overline{\text{STB}}$ input setup time	At error reset	1.0			$\mu\text{s}$
$T_{hS}$	$\overline{\text{STB}}$ input holding time	At error reset	100			ns
$T_{wE}$	ERR input pulse width	At error reset	200			ns

**TIMING DIAGRAM**

**Timing waveform**

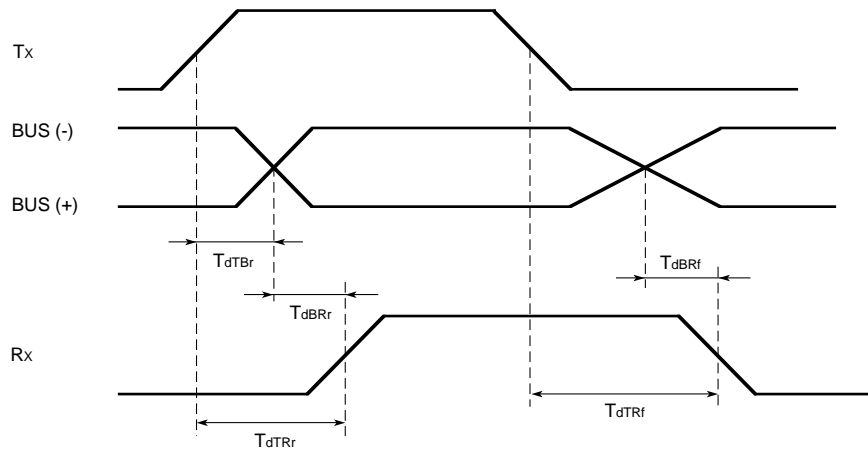

**Error reset timing**

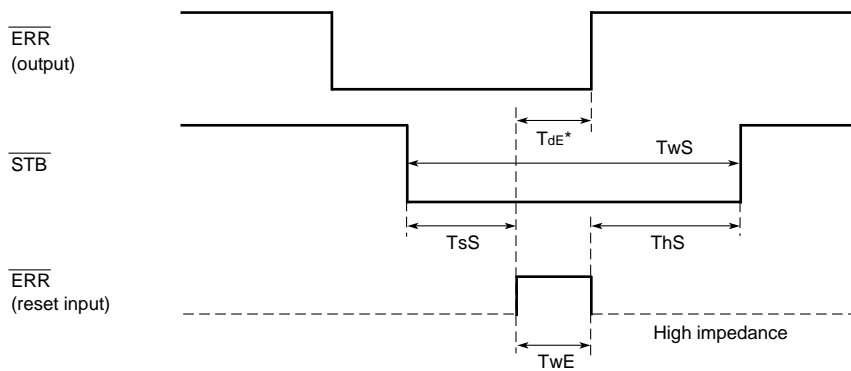

$T_{dE^*}$  = about 20ns (reference value)

**APPLICATION EXAMPLE** (This is only an example, so it allows more examination if necessary)

**Transmission route connection example**

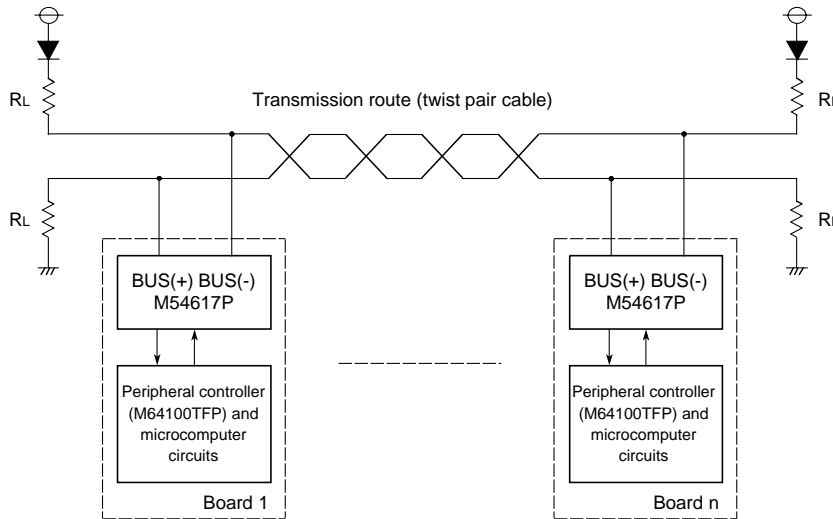

**Peripheral circuit example**

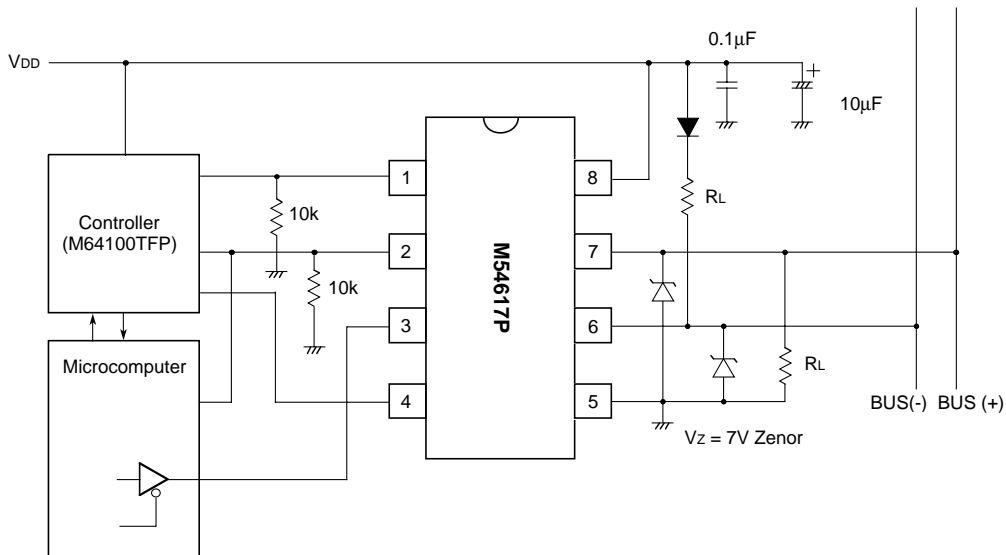

- Use of Zener diode in the range of  $V_z = 7V$  is recommended for surge protection.
- Installation of external capacitance is recommended between the power supply pin and GND in order to prevent malfunction due to noise, etc.
- In the example given, terminal resistor is connected to the edge of transmission route in the transmission route connection, but the method of connecting terminal resistor to each node is recommended. In this case, pay attention to the total terminal resistance value of the transmission route.