

M54679SP

2-Phase Stepper Motor Driver

REJ03F0052-0100Z

Rev.1.0

Sep.17.2003

Description

The M54679SP is a semiconductor integrated circuit that can drive the bipolar stepping motor directly by controlling the coil-current at low level.

Features

- Wide supply voltage sphere (10 to 35 V)
- Bipolar, constant current PWM function.
(Topside transistors PWM function, maximum current is 0.8 Amps.)
- Few external components.
(This IC can be operated with 1 capacitor and 2 resistances.)
- 4 phases input style (include the protection function of output through current).
- Output current charge function (2 bits, 4 type currents).
- Thermal protection circuit.
- Include flywheel diodes.

Application

- Printer, PPC and Facsimile.

Function

The M54679SP is a semiconductor integrated circuit, which can drive to phase stepper motor. It can control the direction of motor current and output motor current (4 steps) by I0, I1 terminals. Also, it can drive the two-phase bipolar stepper motor by one IC as it includes two current control circuits.

Block Diagram

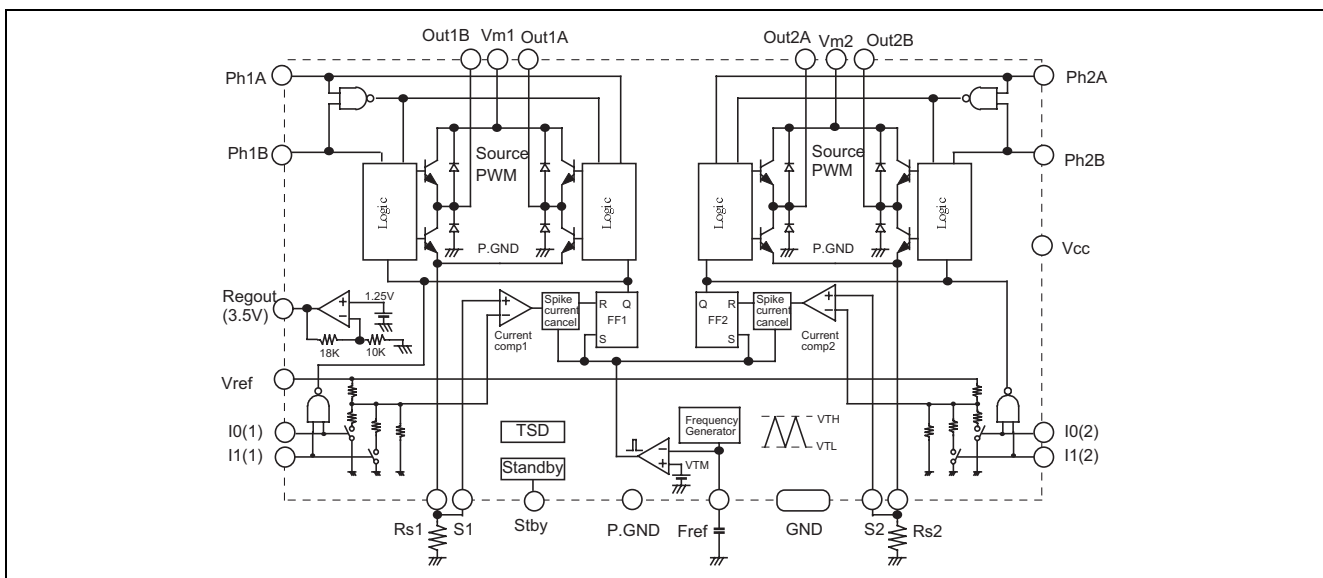

Pin Configuration (Top View)

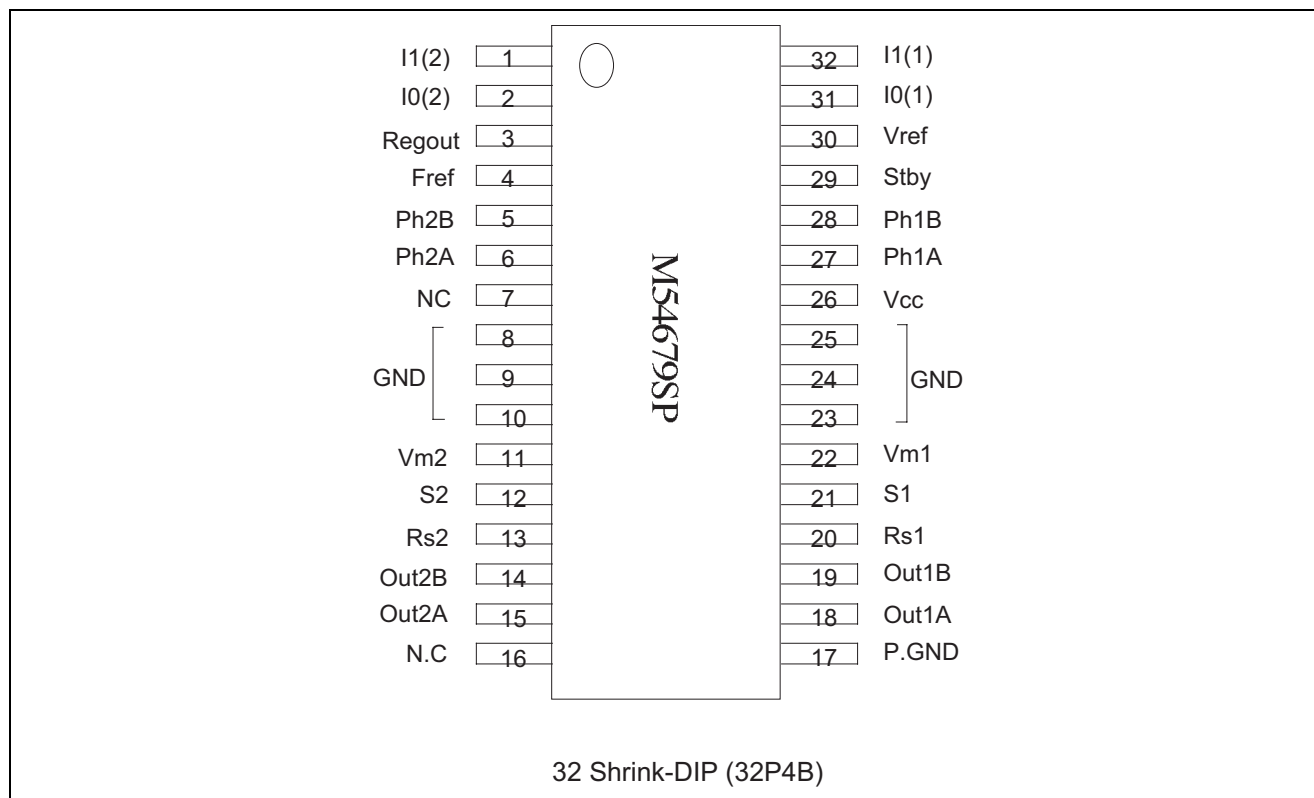

Pin Functions

Symbol	Terminal	Function
Vm1, Vm2	Motor supply voltage	Power supply for motor driver.
Out1A, Out1B, Out2A, Out2B,	Output terminals	Motor drive output terminals.
Rs1, Rs2	Current sensor	Output current sensing resistor (Rs) connection terminals.
Vcc	Power supply	Control circuit power supply.
Ph1A, Ph1B, Ph2A, Ph2B	Phase input	Output current direction switch terminals.
I0(1), I1(1), I0(2), I1(2),	Output current change	Output current change (100%, 70%, 31%, 0%) terminals.
Stby	Standby input	Standby input (L: standby, H or Open: motor function) terminal.
S1, S2	Sense inputs	Input voltage terminal of comparators.
Vref	Vref input	Reference voltage due to setting output current.
Regout	Output of voltage stabilizer	Output of voltage stabilizer (Vout = 3.5 V).
Fref	A capacitor for oscillator	A capacitor due to PWM carrier frequency.
P.GND	Power GND	The GND terminal of bottom side flywheel diodes.

Absolute Maximum Ratings

(Ta = 25°C unless otherwise noted)

Symbol	Parameter	Conditions	Rating	Unit
Vm	Motor supply voltage		-0.3 to 37	V
Iout	Output current	Per one phase	±0.8	A
Vcc	Power supply		-0.3 to 7.0	V
Vlogic	Logic input voltage	Ph1A, Ph1B, Ph2A, Ph2B, I0, I1, stby	-0.3 to Vcc	V
Vanalog	Analog input voltage	Vref S1, S2	-0.3 to Vcc	V
VRs	Output current sensing	Rs1, Rs2	1.5	V
Pd	Power dissipation		1.7	W
Tj	Junction temperature		150	°C
Topr	Operating temperature		-20 to 75	°C
Tstg	Storage temperature		-40 to 125	°C

Thermal Derating Curve

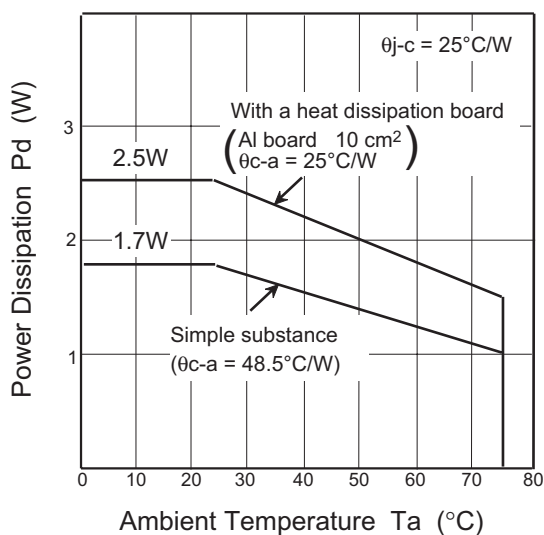

Recommended Operating Conditions

Symbol	Parameter	Limits			Unit
		Min.	Typ.	Max.	
Vcc	Power supply	4.5	5.0	5.5	V
Vm	Motor supply voltage	10	—	35	V
Iout	Output current	50	—	800	mA
tPLH	Rising time of logic inputs	—	—	2.0	μs
tPHL	Falling time of logic inputs	—	—	2.0	μs
Ton	PWM ON time	5.0	—	50	μs
Toff	PWM OFF time	5.0	—	50	μs
TSDon	Thermal shut down	—	160	—	°C

Electrical Characteristics

(Ta = 25°C, Vcc = 5 V, VM = 24 V unless otherwise noted.)

Control circuit

Symbol	Parameter	Conditions	Limits			Unit
			Min	Typ	Max	
I _{CC1}	Supply current	Stby = H, Ph*A = H, Ph*B = L (Bridge ON)	39	56	73	mA
I _{CC2}		Stby = H, Ph*A = Ph*B (Bridge OFF)	20	27	40	
I _{CC3}		Stby = L (Standby condition)	1.5	4.0	6.5	
I _{m12}	Motor supply current (standby)	Stby = L	-10	0	100	μA
V _{logicH}	Logic input voltage	Note	2.4	—	V _{CC}	V
V _{logicH}	(Ph, I1, I0, Stby terminals)		0	—	0.6	
I _{(PH)H}	Phase terminal input current	V _{in} = 5 V	—	—	10	μA
I _{(PH)L}		V _{in} = 0 V	-20	-3.0	—	
I _{(I0, I1)H}	I0, I1 terminal input current	V _{in} = 5 V	—	—	10	μA
I _{(I0, I1)L}		V _{in} = 0 V	-400	-300	—	
I _{(stby)H}	Standby terminal input current	V _{in} = 5 V	—	—	10	μA
I _{(stby)L}		V _{in} = 0 V	-400	-300	—	
I _(S)	Current sensing comparators input current	S1 or S2 terminals input current (S = 0 V, V _{ref} = 5 V).	-20	-3.0	—	μA
V _(S)	Current sensing comparators input voltage sphere	S1 or S2 terminals input voltage sphere	0	—	V _{CH(H)}	V
I _(Vref)	V _{ref} input current	Input current of V _{ref} (V _{ref} = 5 V, I0 = I1 = 0 V)	—	500	650	μA
V _(Vref)	V _{ref} input voltage sphere		0	—	V _{CC}	V
F _C	Oscillation frequency of F _{ref}	C = 390 pF, F _{ref} terminal oscillation	20	30	40	kHz
V _{reg}	Voltage stabilizer output	I _{out} = -0.1 mA to +1 mA	3.35	3.50	3.65	V
V _{CH(H)}	Current sensing comparators threshold voltage	I0 = L, I1 = L, V _{ref} = 5 V (V _{ref} /10*100%)	475	500	525	mV
V _{CH(M)}		I0 = H, I1 = L, V _{ref} = 5 V (V _{ref} /10*70%)	325	350	375	mV
V _{CH(L)}		I0 = L, I1 = H, V _{ref} = 5 V (V _{ref} /10*31%)	139	155	171	mV

Note: The logic reference voltage depends on the diode, and changes according to the temperature. Please consider the change in the temperature when setting the voltage level input to the logic.

Output circuit

(Ta = 25°C, Vcc = 5 V, VM = 24 V unless otherwise noted.)

Symbol	Parameter	Conditions	Limits			Unit
			Min	Typ	Max	
Vsat	Output saturation voltage	Top and Bottom at load current 0.6 A	—	1.6	2.2	V
Ileak	Output leakage current		-100	—	+100	μA
V _{F(H)}	V _F of flywheel diode (top)	I _f = 0.6A	—	1.7	2.3	V
V _{F(L)}	V _F of flywheel diode (bottom)	I _f = 0.6A	—	1.1	1.5	V
tdon	Turn ON delay of output	Time until output become ON since V _{ref} = 2.5 V → 0.5 V	—	0.5	2.0	μS
tdoff	Turn OFF delay of output	Time until output become OFF since V _{ref} < S	—	2.0	3.5	μS
tdstby	OFF delay of standby	Time until output become ON since Stby = L → H	—	3.0	10.0	μS
tdph	Phase delay	Time until output become ON since Phase = L → H	—	3.0	10.0	μS

Function Explanation

(1) Ph inputs make a decision the output function. (Ph input of phase 4)

Ph*A	Ph*B	Out*A	Out*B
L	L	OFF	OFF
H	L	H	L
L	H	L	H
H	H	OFF	OFF

*: 1 or 2

Note: The outputs shut off under Ph*A and Ph*B High condition at the same time.

(2) Output current and terminal of output current setting.

I0	I1	Output current ratio	Current sensing comparators threshold voltage (V _{ref} = 5 V)
L	L	100%	500 mV
H	L	70%	350 mV
L	H	31%	155 mV
H	H	0%	—

(3) Equivalent circuit of Vref terminal.

The equivalent circuit of Vref terminal is shown in bellow circuit. As Vref terminal needs typical 500 μ A input current, consider this value when Vref voltage is set.

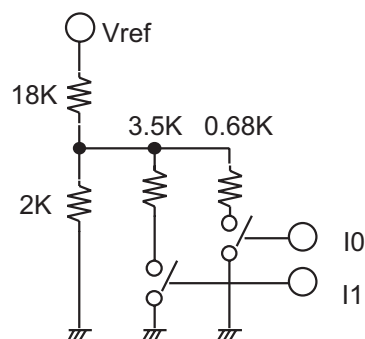

(4) Current sensing comparators.

The current sensing comparators compare the voltage (V_{RS}) of current sensing resistor and threshold voltage (V_{CH}) of this comparators, then if $V_{RS} > V_{CH}$, the comparators output change and shut off the output.

(5) Oscillation circuit.

External capacitor (390 pF typ) is charged and discharged by the constant current and a triangular waveform (V_{TH} (Fref terminal high voltage) = 2.5 V, V_{TL} (Fref terminal low voltage) = 0.5 V) appears to Fref terminal.

This triangular waveform is a carrier frequency of PWM circuit. The carrier frequency changes if this external capacitor value is changed.

M54679SP is designed that the oscillation frequency is 30 kHz if the external capacitor value is 390 pF.

The oscillation frequency is in inverse proportion to the value of an external capacitor.

(6) Spike current cancellation.

Output power transistors go to ON, then the spike current appears on the R_s (current sensing) in a short time and this is caused by the internal delay time. M54679SP has the cancellation circuit of the spike current as the current sensing comparators do not cause error functions.

So, the function of current sensing comparators is shut off during 2 μ s since the output power transistors go to ON.

(7) Ph signal delay circuit.

M54679SP has a delay time of 3.0 μ s until output H-bridge power stage go to ON since Ph signal change Low to high. This delay time is enough short time for the frequency (plus rate) of Ph signal and there is no problem in the normal function.

(8) R_s and S1 or S2 terminal.

If S1 or S2 terminal (non-inverted input of the current sensing comparators) is connected the nearest position of current sensing resistor, the error of the current sensing by means of wire resistance on the board will be decreased.

(9) Voltage stabilizer.

M54679SP has a voltage stabilizer of 3.5 V. The reference voltage (Vref) can connect the output (Regout) of voltage stabilizer directly. In this case, the current capability of the output of voltage stabilizer is 1.0 mA (source current), 0.1 mA (sink current).

(10) Setting output current.

As the output circuit of M54679SP is designed by the bipolar type NPN transistors, the current that go through the motor coil is smaller about 15 mA (typical) than the current that go through the current sensing resistor. This is caused by the base current of the power transistors.

Therefore, be aware this base current when the output current is set.

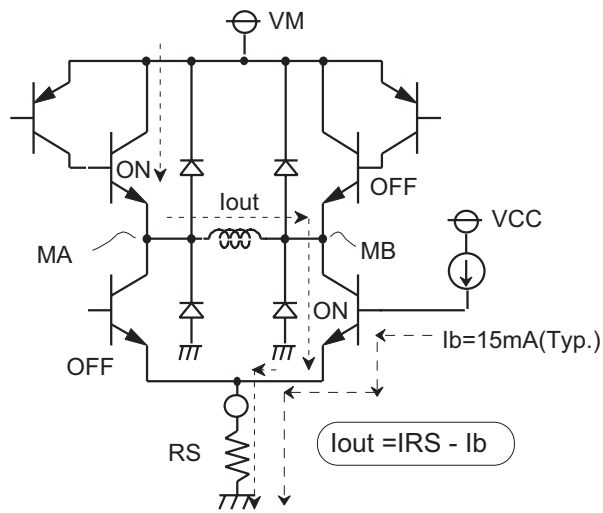
**(11) Power GND terminal.**

Power GND is connected the anodes of flywheel diodes of bottom side. When the output H-bridge power stage goes to ON, as the flyback current go through this GND terminal, minimize the wire resistor of this GND on the board.

(12) Output current timing chart under Ph inputs and I0, I1 output conditions.

Under output current waveforms show the current that a motor driver is going to control, so these do not show the actual current waveforms. The waveform of the current when motor is driven becomes a corrupted-curved waveform when the current changes due to the inductance of the motor.

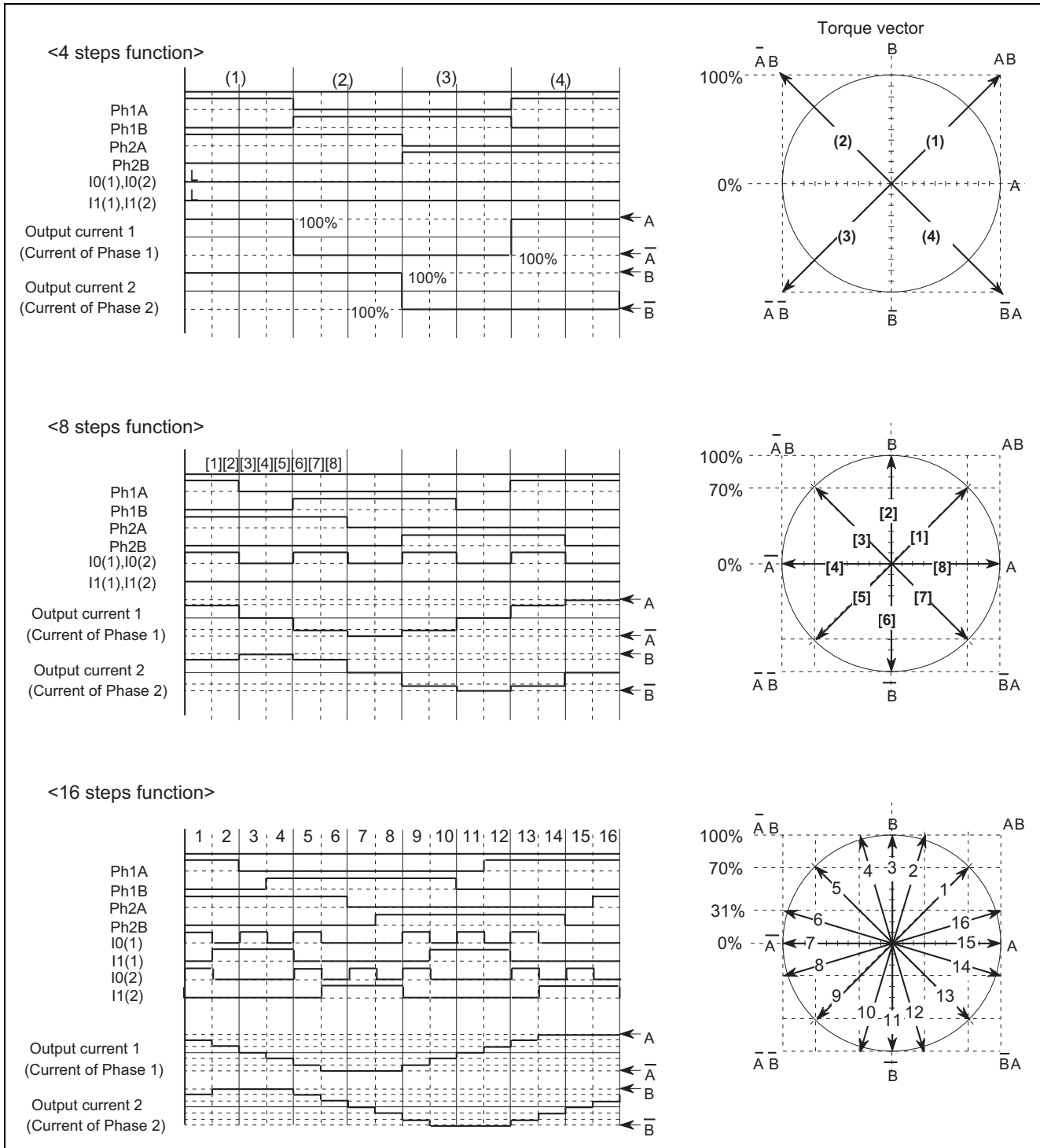

(13) Input terminal

Symbol	Equivalent circuit of the circumstance of input terminals	Remarks
Stby I0(1) I1(1) I0(2) I1(2)		
Ph1A Ph1B Ph2A Ph2B		
S1 S2		
Vref		
Fref		

Application Circuit

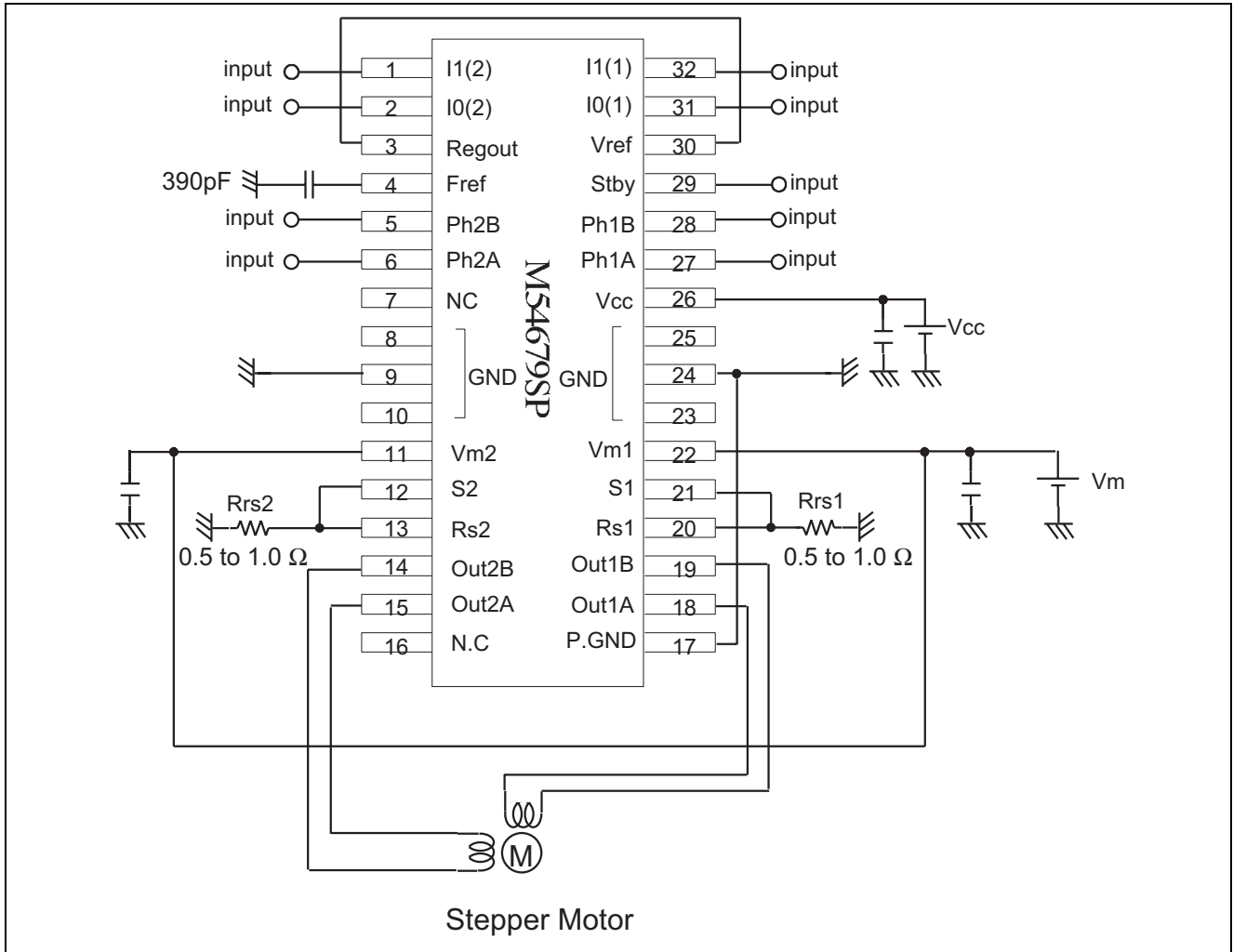

Package Dimensions

Plastic 32pin 400mil SDIP

(MMP)

32P4B

EIAJ Package Code SDIP32-P-400-1.78	JEDEC Code —	Weight(g) 2.2	Lead Material Alloy 42/Cu Alloy
--	-----------------	------------------	------------------------------------

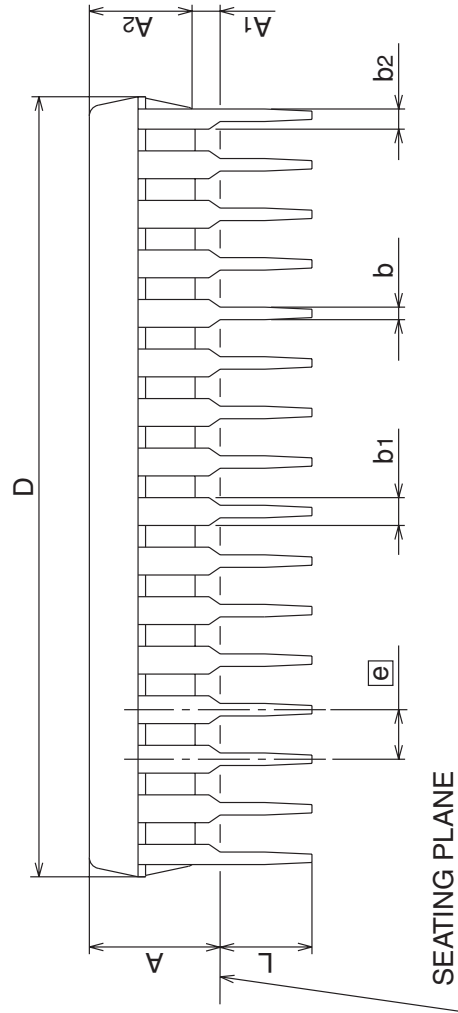
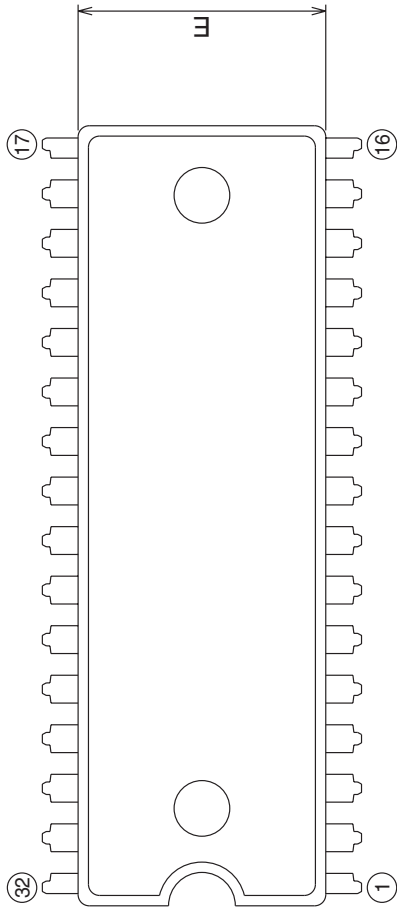
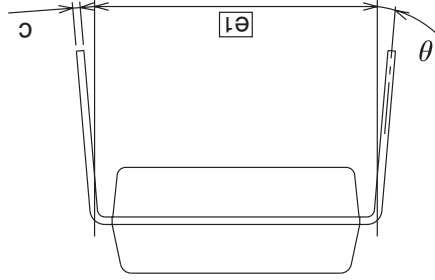

Symbol	Dimension in Millimeters		
	Min	Nom	Max
A	—	—	5.08
A1	0.51	—	—
A2	—	3.8	—
b	0.35	0.45	0.55
b1	0.9	1.0	1.3
b2	0.63	0.73	1.03
c	0.22	0.27	0.34
D	27.8	28.0	28.2
E	8.75	8.9	9.05
e	—	1.778	—
e1	—	10.16	—
L	3.0	—	—
θ	0°	—	15°

Renesas Technology Corp. Sales Strategic Planning Div. Nippon Bldg., 2-6-2, Ohte-machi, Chiyoda-ku, Tokyo 100-0004, Japan

Keep safety first in your circuit designs!

1. Renesas Technology Corp. puts the maximum effort into making semiconductor products better and more reliable, but there is always the possibility that trouble may occur with them. Trouble with semiconductors may lead to personal injury, fire or property damage.
Remember to give due consideration to safety when making your circuit designs, with appropriate measures such as (i) placement of substitutive, auxiliary circuits, (ii) use of nonflammable material or (iii) prevention against any malfunction or mishap.

Notes regarding these materials

1. These materials are intended as a reference to assist our customers in the selection of the Renesas Technology Corp. product best suited to the customer's application; they do not convey any license under any intellectual property rights, or any other rights, belonging to Renesas Technology Corp. or a third party.
 2. Renesas Technology Corp. assumes no responsibility for any damage, or infringement of any third-party's rights, originating in the use of any product data, diagrams, charts, programs, algorithms, or circuit application examples contained in these materials.
 3. All information contained in these materials, including product data, diagrams, charts, programs and algorithms represents information on products at the time of publication of these materials, and are subject to change by Renesas Technology Corp. without notice due to product improvements or other reasons. It is therefore recommended that customers contact Renesas Technology Corp. or an authorized Renesas Technology Corp. product distributor for the latest product information before purchasing a product listed herein.
The information described here may contain technical inaccuracies or typographical errors.
Renesas Technology Corp. assumes no responsibility for any damage, liability, or other loss rising from these inaccuracies or errors.
Please also pay attention to information published by Renesas Technology Corp. by various means, including the Renesas Technology Corp. Semiconductor home page (<http://www.renesas.com>).
 4. When using any or all of the information contained in these materials, including product data, diagrams, charts, programs, and algorithms, please be sure to evaluate all information as a total system before making a final decision on the applicability of the information and products. Renesas Technology Corp. assumes no responsibility for any damage, liability or other loss resulting from the information contained herein.
 5. Renesas Technology Corp. semiconductors are not designed or manufactured for use in a device or system that is used under circumstances in which human life is potentially at stake. Please contact Renesas Technology Corp. or an authorized Renesas Technology Corp. product distributor when considering the use of a product contained herein for any specific purposes, such as apparatus or systems for transportation, vehicular, medical, aerospace, nuclear, or undersea repeater use.
 6. The prior written approval of Renesas Technology Corp. is necessary to reprint or reproduce in whole or in part these materials.
 7. If these products or technologies are subject to the Japanese export control restrictions, they must be exported under a license from the Japanese government and cannot be imported into a country other than the approved destination.
Any diversion or reexport contrary to the export control laws and regulations of Japan and/or the country of destination is prohibited.
 8. Please contact Renesas Technology Corp. for further details on these materials or the products contained therein.
-



RENESAS SALES OFFICES

<http://www.renesas.com>

Renesas Technology America, Inc.
450 Holger Way, San Jose, CA 95134-1368, U.S.A
Tel: <1> (408) 382-7500 Fax: <1> (408) 382-7501

Renesas Technology Europe Limited.
Dukes Meadow, Millboard Road, Bourne End, Buckinghamshire, SL8 5FH, United Kingdom
Tel: <44> (1628) 585 100, Fax: <44> (1628) 585 900

Renesas Technology Europe GmbH
Dornacher Str. 3, D-85622 Feldkirchen, Germany
Tel: <49> (89) 380 70 0, Fax: <49> (89) 929 30 11

Renesas Technology Hong Kong Ltd.
7/F., North Tower, World Finance Centre, Harbour City, Canton Road, Hong Kong
Tel: <852> 2265-6688, Fax: <852> 2375-6836

Renesas Technology Taiwan Co., Ltd.
FL 10, #99, Fu-Hsing N. Rd., Taipei, Taiwan
Tel: <886> (2) 2715-2888, Fax: <886> (2) 2713-2999

Renesas Technology (Shanghai) Co., Ltd.
26/F., Ruijin Building, No.205 Maoming Road (S), Shanghai 200020, China
Tel: <86> (21) 6472-1001, Fax: <86> (21) 6415-2952

Renesas Technology Singapore Pte. Ltd.
1, Harbour Front Avenue, #06-10, Keppel Bay Tower, Singapore 098632
Tel: <65> 6213-0200, Fax: <65> 6278-8001