

DESCRIPTION

M56760FP is a PLL frequency synthesizer for wirelessphone. Two modulus prescalers of 1/128 and 1/129 are incorporated, and direct input of maximum 540MHz is available.

FEATURES

- Two modulus prescalers of 1/128 and 1/129 are incorporated. ($f_{max}=540\text{MHz}$)
- Large range of operating supply voltage ($V_{CC}=3.0\sim 5.5\text{V}$)
- Low current consumption ($I_{CC}=14\text{mA}$ at $V_{CC}=3\text{V}$)
- Divider for reference frequency is also programmable. Setting range of dividing ratio N (f_{REF}) = 128 ~ 16,376 (can be set by multiples of 8)
- Programmable divider for local oscillator
Setting range of dividing ratio N (V. C. O) = 16,384 ~ 131,071 (can be set by multiples of integer)
- Serial data input system
- PLL lock/unlock status indication function
- PLL power on/off can be controlled by transmitted data from controller (Standby current at off is 4mA.)
- Output port whose status can be set by transmitted data from controller
- Transistor for LPF is incorporated.

PIN CONFIGURATION (TOP VIEW)

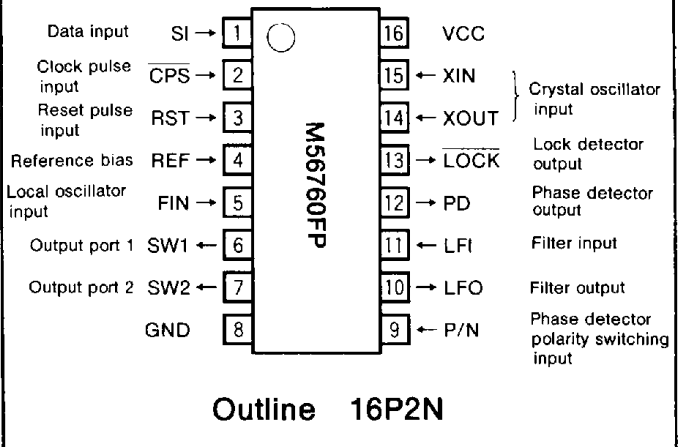

APPLICATION

Wirelessphone

BLOCK DIAGRAM

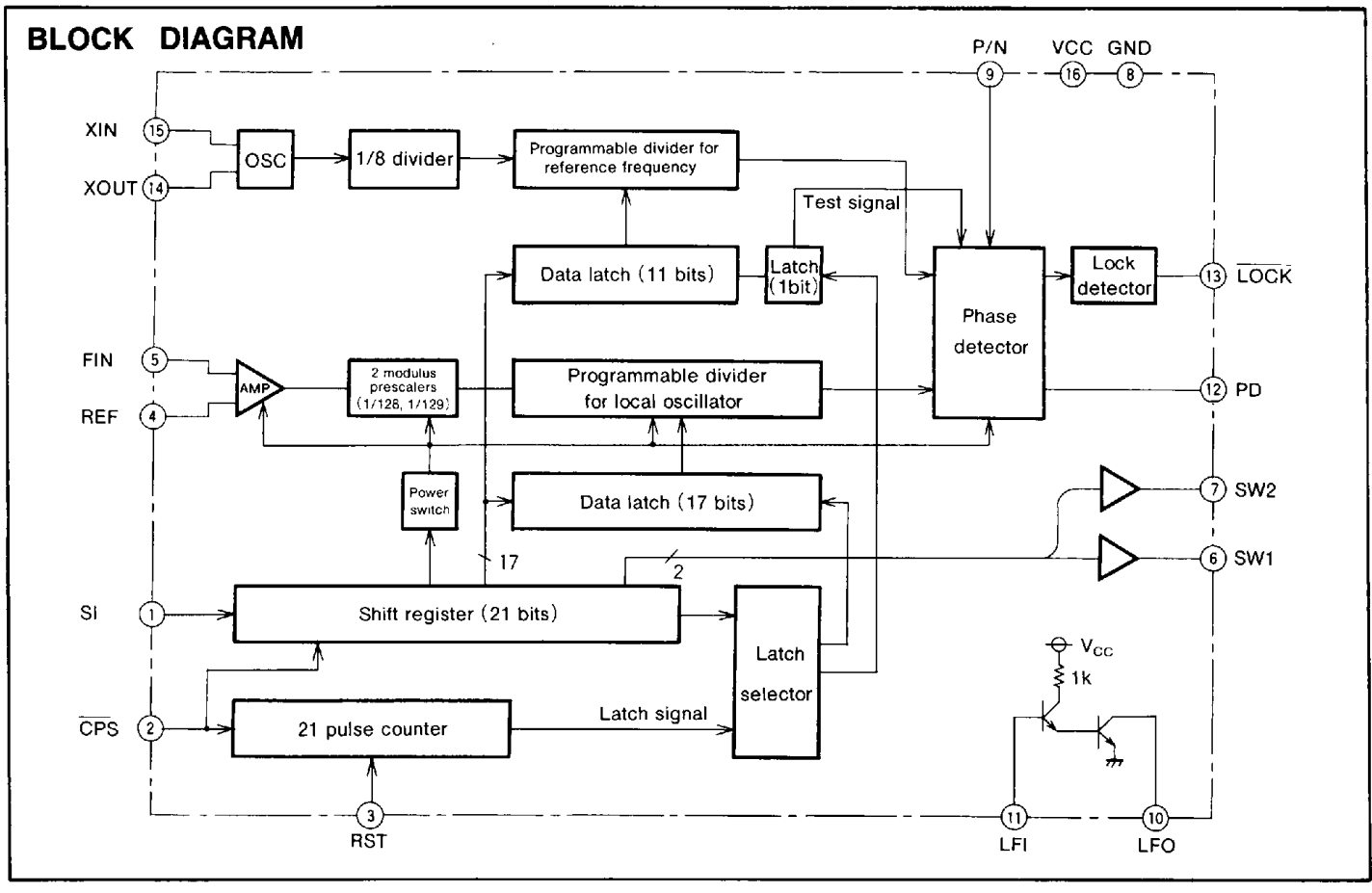

PIN DESCRIPTION

Pin no	Symbol	Pin name	Description
1	SI	Data input	Data input terminal of shift register
2	$\overline{\text{CPS}}$	Clock pulse input	Clock pulse input terminal of shift register
3	RST	Reset pulse input	Reset pulse input terminal of 21 pulse counter
4	REF	Reference bias	Grounded with 1000pF condenser.
5	FIN	Local oscillator input	Local oscillator frequency (V. C. O) input.
6	SW1	Output port1	Output port whose status can be set by transmitted data from controller. Open collector
7	SW2	Output port2	
8	GND	Ground	0V
9	P/N	Phase detector polarity switching input	When this terminal is at "H", PD terminal becomes "H" for phase lead, and "L" for phase lag. When this terminal is at "L", PD terminal becomes "L" for phase lead, and "H" for phase lag.
10	LFO	Filter output	Collector output of transistor for LPF
11	LFI	Filter input	Base input of transistor for LPF
12	PD	Phase detector output	Tristate output
13	$\overline{\text{LOCK}}$	Lock detector output	When PLL system is locked "L" When PLL system is unlocked "H" Open collector
14	X _{OUT}	Crystal oscillator input	Output from 12.8MHz reference oscillator is input to XIN. Oscillator by external crystal resonator is available.
15	X _{IN}		
16	V _{CC}	Power terminal	

FUNCTION

1. DATA INPUT

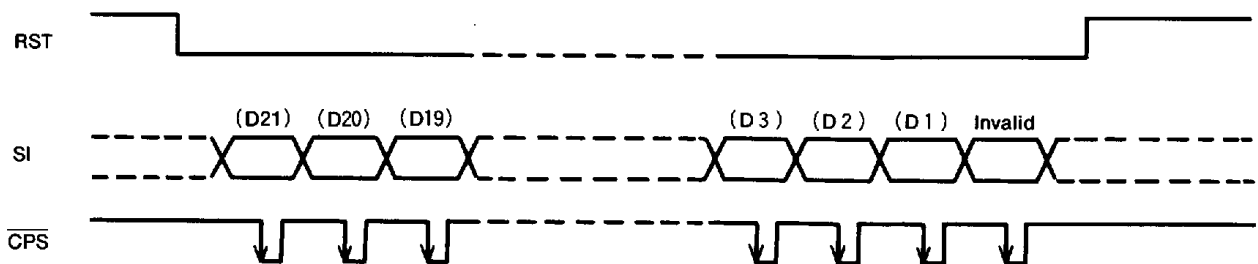

- Note 1 : SI input status is read into the shift register in sequence at the trailing edge of CPS input.
- 2 : All the data(power on/off, latch selection, Nvalue, SW on/off)is set at the CPS trailing edge of the 21st pulse, and later CPS is invalid.
- 3 : Neither CPS nor SI is accepted while RST is at "H" .

2. TIMING OF INPUT SIGNAL

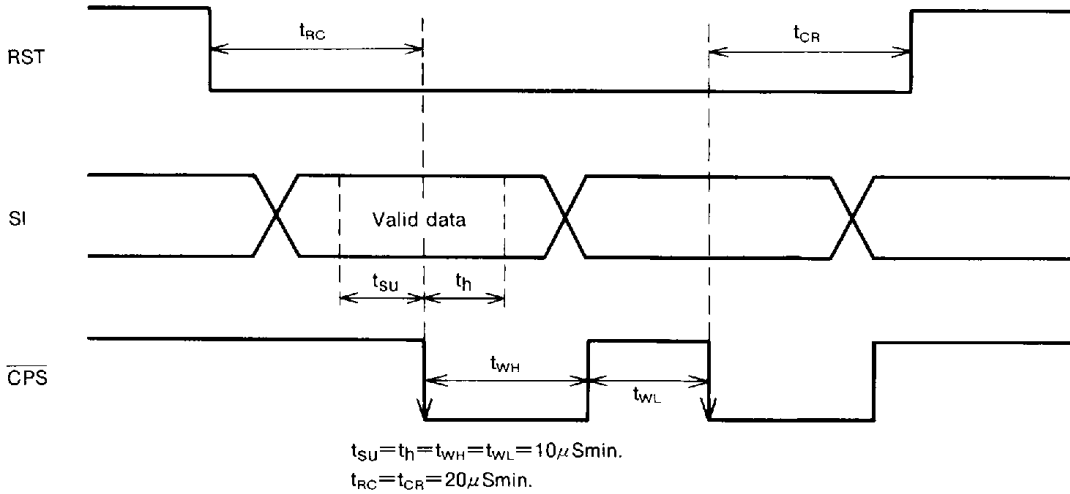

3. BIT CONFIGURATION OF SHIFT REGISTER

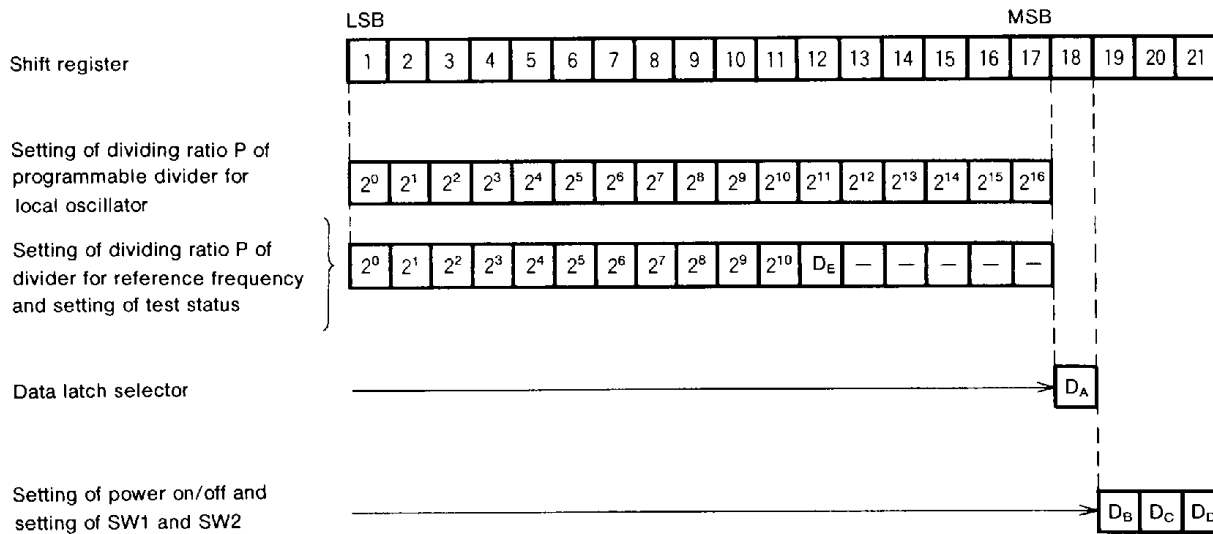

Note 4 : Dividing ratio P of programmable divider is given in 17 bits for divider for local oscillator and in 11 bits for divider for reference frequency.

- Total dividing ratio of local oscillator frequency $N(V.C.O)$ is;
 $N(V.C.O) = P$, where $P = 16,384 \sim 131,071$
- Total dividing ratio of reference frequency $N(f_{REF})$ is;
 $N(f_{REF}) = 8 \cdot P$, where $P = 16 \sim 2,047$
 12nd bit data D_E is for test mode. Always set to "L" in normal operation.
 Input "H" or "L" to the 13rd through 17th bits as dummy data.

Data	Status
D_E	
L	Normal
H	Test mode

Note 5 : Data latch to be updated is selected by D_A .

Data	Explanation
D_A	
H	Data of latch for reference frequency is updated.
L	Data of latch for local oscillator is updated.

Note 6 : Power on/off of SW1, SW2, and PLL system is set by Db, Dc, and Dd.

Data		Output port	
D ₃	D _C	SW2	SW1
L	L	ON	ON
H	L	OFF	ON
L	H	ON	OFF
H	H	OFF	OFF

Data	PLL
D _D	Power switch
L	ON
H	OFF

4. DATA CODING EXAMPLE

(1) Setting : Reference frequency 12.5kHz, PLL power off, SW1 off, and SW2 off.

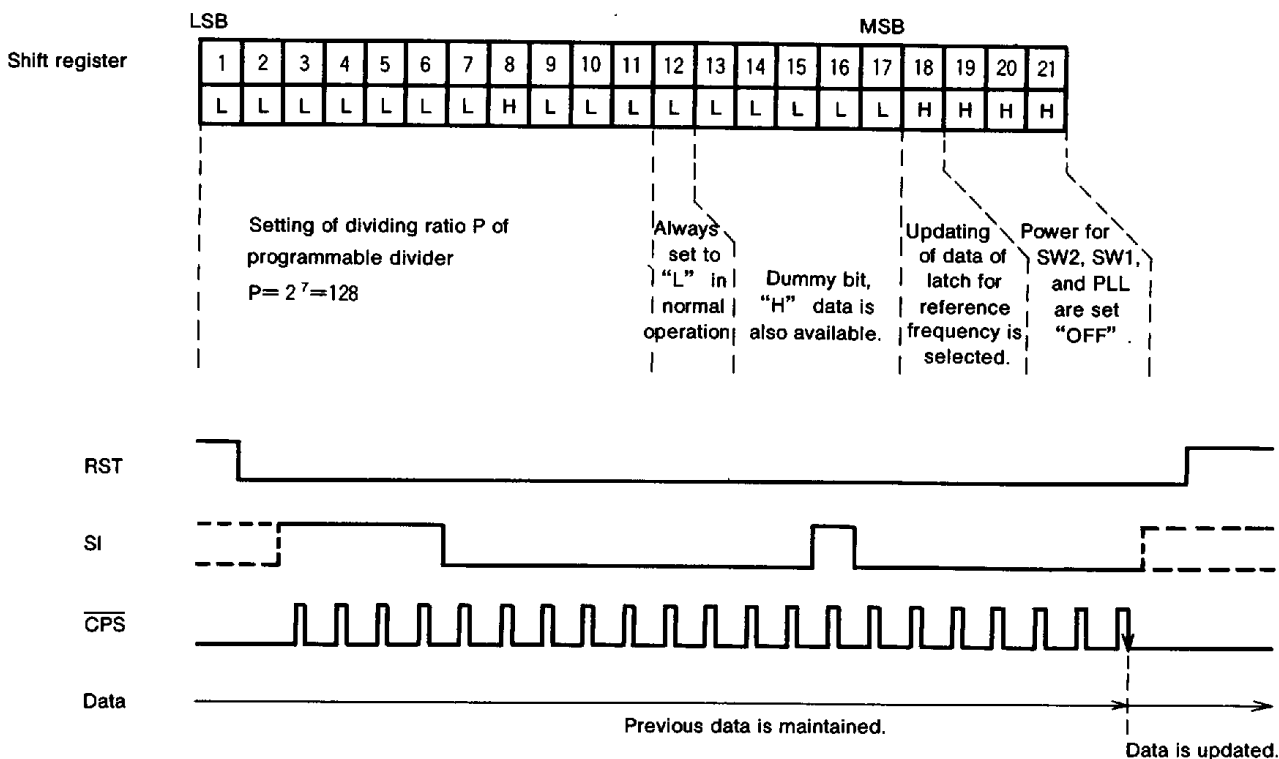

Note 7 : Total dividing ratio of reference frequency $N(f_{REF})$ is set as follows:

$$N(f_{REF}) = 8 \cdot P = 8 \times 128 = 1024$$

when 12.8MHz crystal oscillator is used,
 $f_{REF} = 12,800 / 1024 = 12.5\text{kHz}$

(2) Setting : Dividing ratio for local oscillator 24,000, PLL power on, SW1 off, and SW2 on

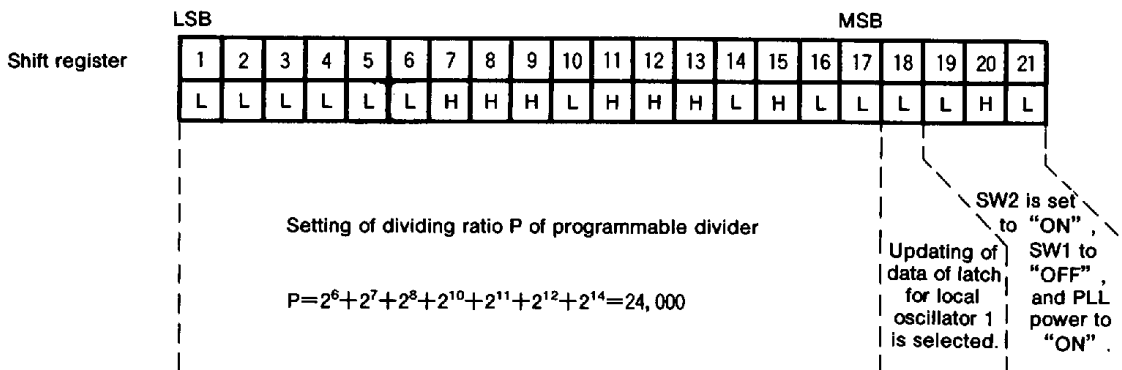

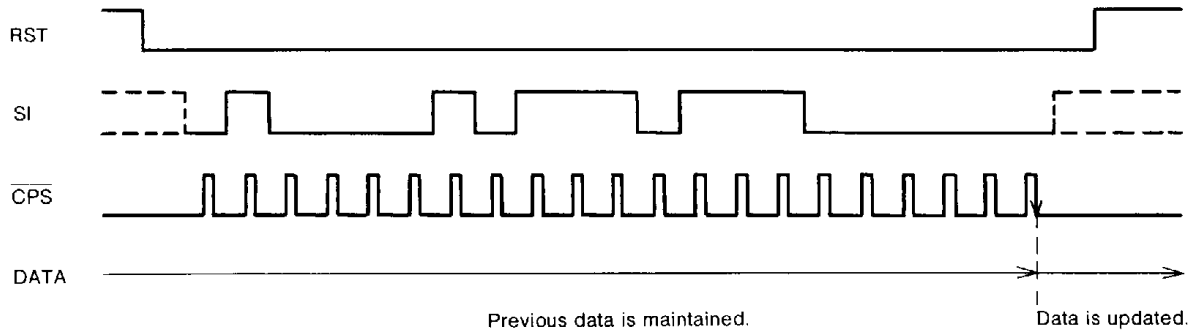

Note 8 : If PLL is locked when the reference frequency is set to 12.5kHz;
 $f_{v.c.o} = 12.5 \times 24,000 = 300,000 \text{kHz} = 300 \text{MHz}$

5. PD, Lock SIGNAL OUTPUT WAVEFORM

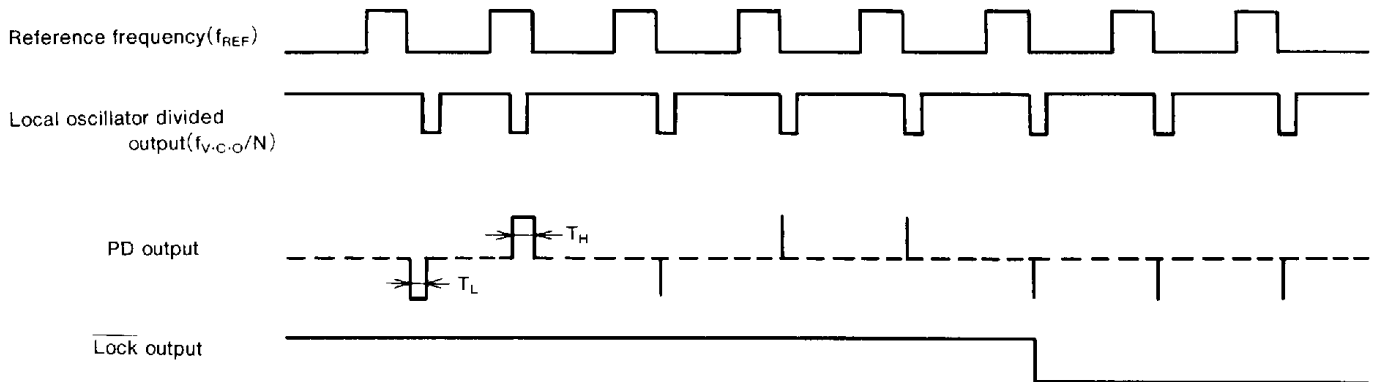

Note 9 : PD output becomes "L" status when the phase of local oscillator divided output ($f_{v.c.o}/N$) is faster than that of reference frequency (f_{REF}) and "H" status when it is behind.
 10 : indicates high impedance status.
 11 : Lock output becomes "L" status when the phase differences T_L and T_H are kept at below 625ns** for more than three cycles of reference frequency (f_r).

* : The above explanation is the case when P/N input (11 pin) is at "H" status.
 In the case that P/N input is at "L" status, polarity of PD output is reversed.
 ** : This is the case when 12.8MHz oscillator is used for reference oscillator frequency.

INPUT/OUTPUT CIRCUIT DRAWING

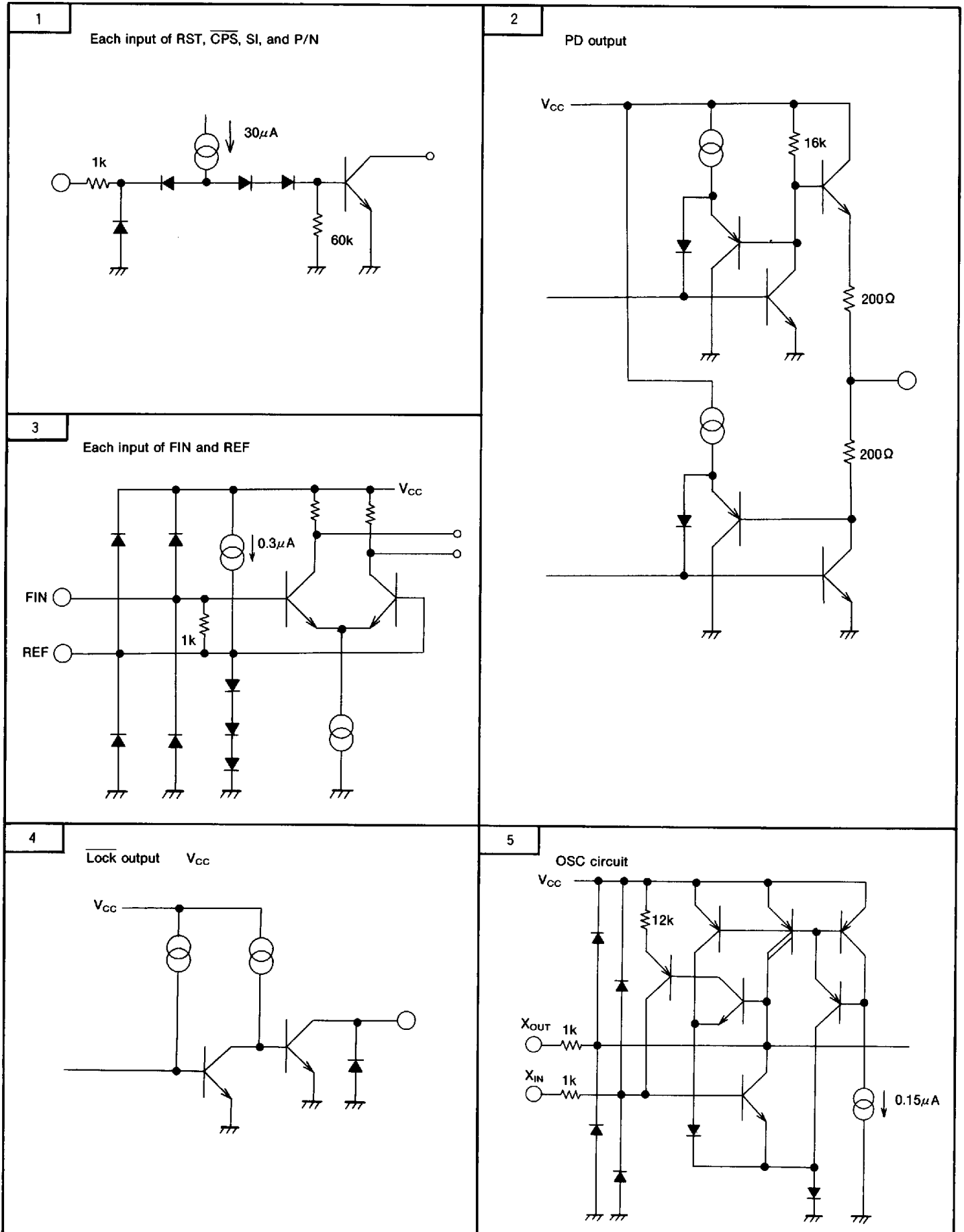

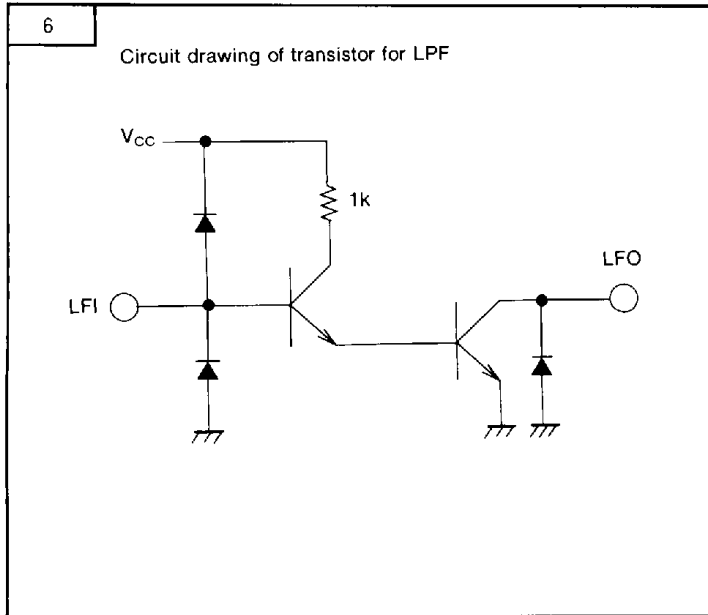

Note12 : Resistance and power source are standard values when $V_{CC}=3V$ and $T_a=25^{\circ}C$.

ABSOLUTE MAXIMUM RATINGS ($T_a=-20^{\circ}C \sim 75^{\circ}C$, unless otherwise noted)

Symbol	Parameter	Conditions	Ratings		Unit	Remarks
			Min.	Max.		
V_{CC}	Supply voltage		-0.5	6.0	V	
V_I	Input voltage	Each input	-0.5	6.0	V	
V_O	Output voltage	Each output	-0.5	6.0	V	
P_d	Power dissipation	$T_a=75^{\circ}C$		300	mW	Allowable power dissipation of package
T_{opr}	Operating ambient temperature		-20	75	$^{\circ}C$	
T_{stg}	Storing ambient temperature		-40	125	$^{\circ}C$	

RECOMMENDED OPERATING CONDITIONS ($T_a=-20 \sim 75^{\circ}C$, unless otherwise noted)

Symbol	Parameter	Conditions	Limits			Unit	Remarks
			Min.	Typ.	Max.		
V_{CC}	Supply voltage	$F_{IN}=100 \sim 540MHz$	3.0		5.5	V	
V_{IN}	Input amplitude	$F_{IN}=100 \sim 540MHz$	160		640	mVp-p	
F_{IN}	Input frequency	$V_{CC}=3.0 \sim 5.5V$	100		540	MHz	
I_{OL}	Low-level output current	Each output of LOCK and LFO			1	mA	
V_{XIN}	XIN input amplitude	$V_{CC}=3.0 \sim 5.5V$ $f_{osc}=10 \sim 15MHz$ sine wave	0.5		2	Vp-p	15.2
f_{osc}	Reference oscillator frequency	$V_{CC}=3.0 \sim 5.5V$ $V_{XIN}=0.5 \sim 2Vp-p$	10	12.8	15	MHz	15.1~2

Connection of crystal resonator

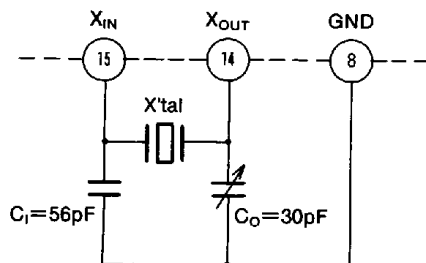

X'tal load capacity 20pF effective resistance 100Ω or less

Connection of crystal oscillator

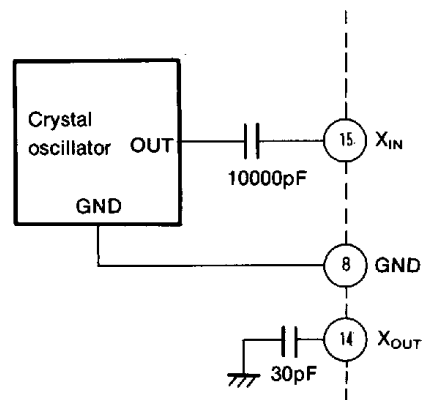

ELECTRICAL CHARACTERISTICS (T_a=-20~75°C, unless otherwise noted)

Symbol	Parameter	Terminal	Test Conditions	Limits			Unit
				Min.	Typ.	Max.	
V _{IH}	High-level input voltage	SI, $\overline{\text{CPS}}$, RST, P/N	V _{CC} =3.0~5.5V	2		5.5	V
V _{IL}	Low-level input voltage	SI, $\overline{\text{CPS}}$, RST, P/N	V _{CC} =3.0~5.5V	0		0.6	V
I _{IH}	High-level input current	SI, $\overline{\text{CPS}}$, RST, P/N	V _{CC} =5.5V V _{IH} =5.5V			10	μA
I _{IL}	Low-level input current	SI, $\overline{\text{CPS}}$, RST, P/N	V _{CC} =5.5V V _{IL} =0V		-30	-60	μA
V _{OL}	Low-level output voltage	$\overline{\text{LOCK}}$	V _{CC} =3.0V I _{OL} =1mA			0.4	V
V _{OHP1}	PD High-level output voltage	PD	V _{CC} =5V I _{OH} =-1mA	3.5			V
V _{OHP2}	PD High-level output voltage	PD	V _{CC} =3.0V I _{OH} =-0.1mA	2			V
V _{OLP1}	PD Low-level output voltage	PD	V _{CC} =5V I _{OL} =1mA			1.5	V
V _{OLP2}	PD Low-level output voltage	PD	V _{CC} =3.0V I _{OL} =0.1mA			1	V
I _{PD1}	PD leak current	PD	V _{CC} =5.5V V _O =0.8~4.7V			±1	μA
I _{PD2}	PD leak current	PD	V _{CC} =5V V _O =2.5V			±100	μA
I _{CC1}	Supply current	V _{CC}	V _{CC} =5.5V	PLL power "OFF"	4	8	mA
I _{CC2}				PLL power "ON"	14	25	mA
I _{OLK}	Output leak current	$\overline{\text{LOCK}}$, LFO	V _{CC} =5.5V V _{OH} =5.5V			5	μA
I _{SIOs}	Input bias current	LFI	V _{CC} =5V I _C =1mA, V _C =2.5V			±1	μA
V _{OL}		SW1 SW2	V _{CC} =3.0V I _{OL} =2mA			0.5	V

Note 13 : GND terminal (8 pin) of this circuit is the reference (0V) for all the voltages.

14 : Current flowing into the circuit is positive (no symbol) and that flowing out is negative (-symbol), and maximum and minimum values are indicated in absolute values.

15 : Typical value is that when V_{CC}=3V and T_a=25°C.

APPLICATION EXAMPLE

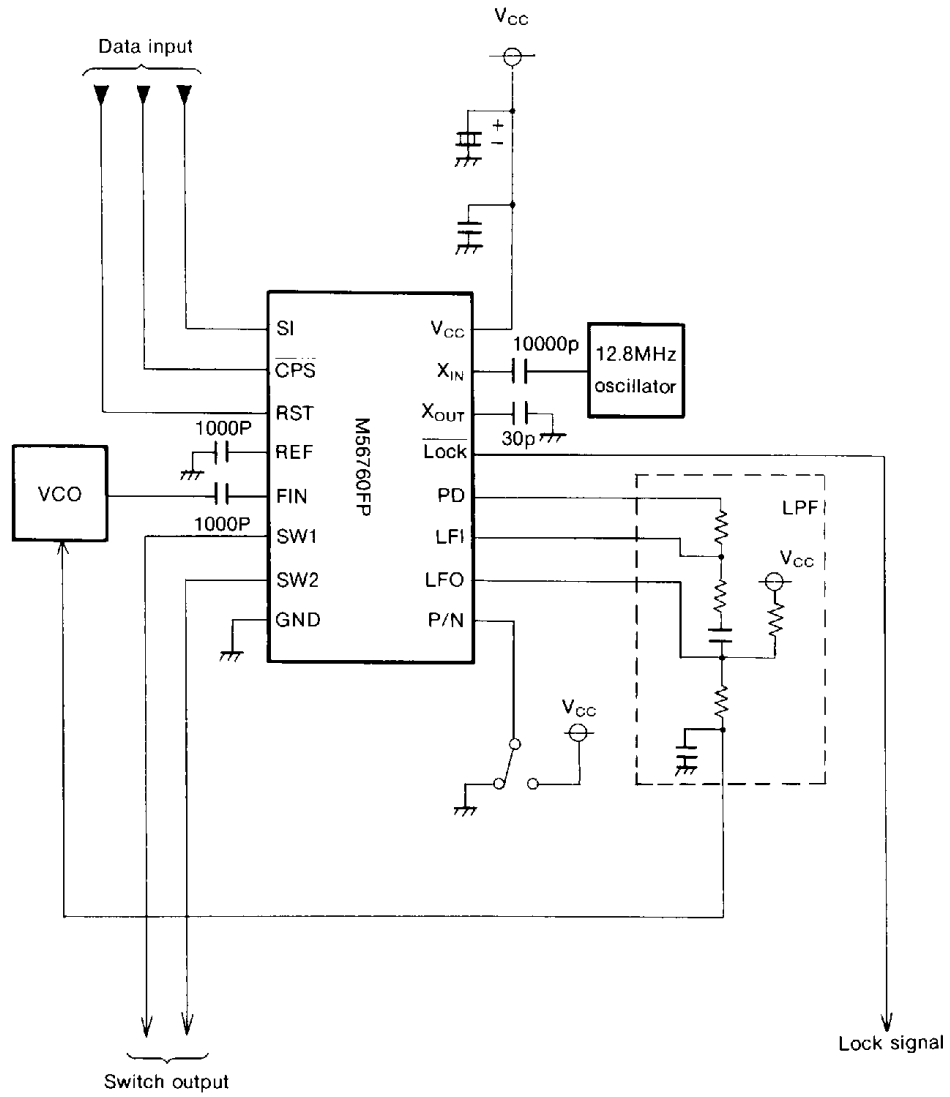

16P2N

Plastic 16pin 300mil(200mil body)SOP

Dimension in mm

