

M5K4164ANL-12, -15

65 536-BIT (65 536-WORD BY 1-BIT) DYNAMIC RAM

DESCRIPTION

This is a family of 65 536-word by 1-bit dynamic RAMs, fabricated with the high performance N-channel silicon gate MOS process, and is ideal for large-capacity memory systems where high speed, low power dissipation, and low costs are essential. The use of double-layer polysilicon process technology and a single-transistor dynamic storage cell provide high circuit density at reduced costs, and the use of dynamic circuitry including sense amplifiers assures low power dissipation. Multiplexed address inputs permit both a reduction in pins to the 16-pin zigzag inline package configuration and an increase in system densities. The M5K4164ANL operates on a 5V power supply using the on-chip substrate bias generator.

FEATURES

- High speed

Type name	Access time (max) (ns)	Cycle time (min) (ns)	Power dissipation (typ) (mW)
M5K4164ANL-12	120	220	175
M5K4164ANL-15	150	260	150

- 16 pin zigzag inline package
- Single 5V±10% supply
- Low standby power dissipation: 22mW (max)
- Low operating power dissipation:
 - M5K4164ANL-12 275mW (max)
 - M5K4164ANL-15 250mW (max)
- Unlatched output enables two-dimensional chip selection and extended page boundary
- Early-write operation gives common I/O capability
- Read-modify-write, \overline{RAS} -only refresh, and page-mode capabilities

PIN CONFIGURATION (TOP VIEW)

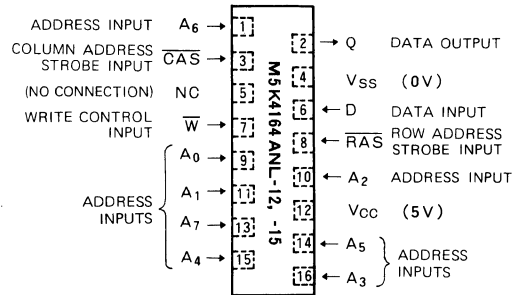

Outline 16P5A

- All input terminals have low input capacitance and are directly TTL-compatible
- Output is three-state and directly TTL-compatible
- 128 refresh cycles every 2ms (16K dynamic RAMs M5K4116P, S compatible)
- \overline{CAS} controlled output allows hidden refresh
- Output data can be held infinitely by \overline{CAS}

APPLICATION

- Main memory unit for computers
- Refresh memory for CRT

BLOCK DIAGRAM

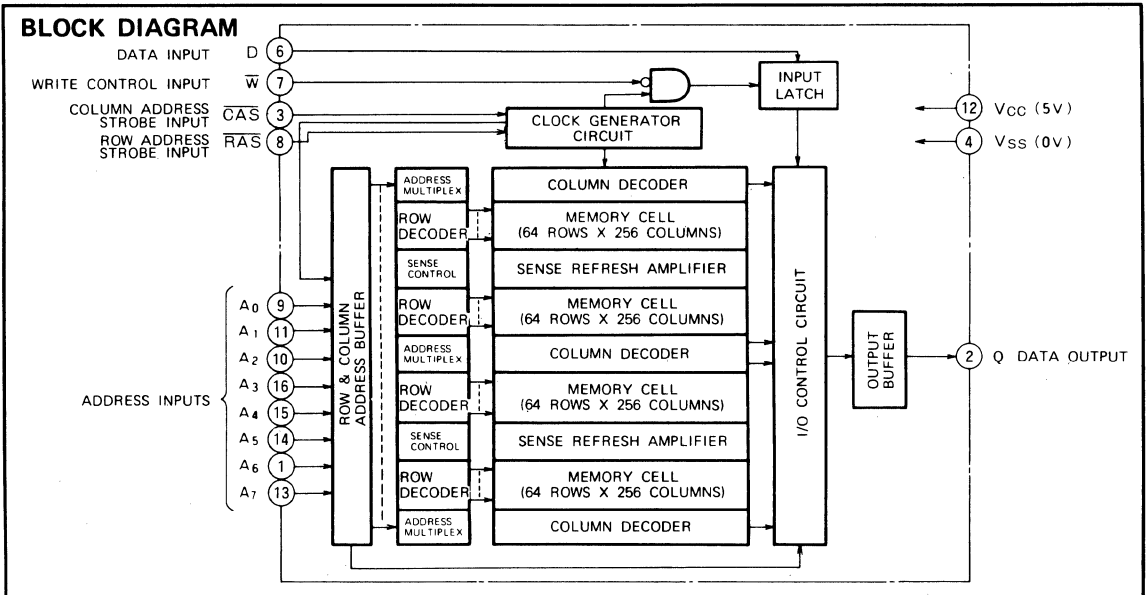

65 536-BIT (65 536-WORD BY 1-BIT) DYNAMIC RAM

FUNCTION

The M5K4164ANL provides, in addition to normal read, write, and read-modify-write operations, a number of other functions, e.g., page mode, $\overline{\text{RAS}}$ -only refresh, and delayed-write. The input conditions for each are shown in Table 1.

Table 1 Input conditions for each mode

Operation	Inputs						Output	Refresh	Remarks
	$\overline{\text{RAS}}$	$\overline{\text{CAS}}$	$\overline{\text{W}}$	D	Row address	Column address	Q		
Read	ACT	ACT	NAC	DNC	APD	APD	VLD	YES	Page mode identical.
Write (Early write)	ACT	ACT	ACT	VLD	APD	APD	OPN	YES	
Read-modify-write	ACT	ACT	ACT	VLD	APD	APD	VLD	YES	
RAS-only refresh	ACT	NAC	DNC	DNC	APD	DNC	OPN	YES	
Hidden refresh	ACT	ACT	DNC	DNC	APD	DNC	VLD	YES	
Standby	NAC	DNC	DNC	DNC	DNC	DNC	OPN	NO	

Note: ACT : active, NAC : nonactive, DNC : don't care, VLD : valid, APD : applied, OPN : open.

SUMMARY OF OPERATIONS

Addressing

To select one of the 65 536 memory cells in the M5K4164ANL the 16-bit address signal must be multiplexed into 8 address signals, which are then latched into the on-chip latch by two externally-applied clock pulses. First, the negative-going edge of the row-address-strobe pulse ($\overline{\text{RAS}}$) latches the 8 row-address bits; next, the negative-going edge of the column-address-strobe pulse ($\overline{\text{CAS}}$) latches the 8 column-address bits. Timing of the $\overline{\text{RAS}}$ and $\overline{\text{CAS}}$ clocks can be selected by either of the following two methods:

1. The delay time from $\overline{\text{RAS}}$ to $\overline{\text{CAS}}$ $t_{d(\text{RAS-CAS})}$ is set between the minimum and maximum values of the limits. In this case, the internal $\overline{\text{CAS}}$ control signals are inhibited almost until $t_{d(\text{RAS-CAS}) \text{ max}}$ ('gated $\overline{\text{CAS}}$ ' operation). The external $\overline{\text{CAS}}$ signal can be applied with a margin not affecting the on-chip circuit operations, e.g. access time, and the address inputs can be easily changed from row address to column address.
2. The delay time $t_{d(\text{RAS-CAS})}$ is set larger than the maximum value of the limits. In this case the internal inhibition of $\overline{\text{CAS}}$ has already been released, so that the internal $\overline{\text{CAS}}$ control signals are controlled by the externally applied $\overline{\text{CAS}}$, which also controls the access time.

Data Input

Data to be written into a selected cell is strobed by the later of the two negative transitions of $\overline{\text{W}}$ input and $\overline{\text{CAS}}$ input. Thus when the $\overline{\text{W}}$ input makes its negative transition prior to $\overline{\text{CAS}}$ input (early write), the data input is strobed by $\overline{\text{CAS}}$, and the negative transition of $\overline{\text{CAS}}$ is set as the

reference point for set-up and hold times. In the read-write or read-modify-write cycles, however, when the $\overline{\text{W}}$ input makes its negative transition after $\overline{\text{CAS}}$, the $\overline{\text{W}}$ negative transition is set as the reference point for setup and hold times.

Data Output Control

The output of the M5K4164ANL is in the high-impedance state when $\overline{\text{CAS}}$ is high. When the memory cycle in progress is a read, read-modify-write, or a delayed-write cycle, the data output will go from the high-impedance state to the active condition, and the data in the selected cell will be read. This data output will have the same polarity as the input data. Once the output has entered the active condition, this condition will be maintained until $\overline{\text{CAS}}$ goes high, irrespective of the condition of $\overline{\text{RAS}}$.

The output will remain in the high-impedance state throughout the entire cycle in an early-write cycle.

These output conditions, of the M5K4164ANL, which can readily be changed by controlling the timing of the write pulse in a write cycle, and the width of the $\overline{\text{CAS}}$ pulse in a read cycle, offer capabilities for a number of applications, as follows.

1. Common I/O Operation

If all write operations are performed in the early-write mode, input and output can be connected directly to give a common I/O data bus.

2 Data Output Hold

The data output can be held between read cycles, without lengthening the cycle time. This enables extremely flexible clock-timing settings for $\overline{\text{RAS}}$ and $\overline{\text{CAS}}$.

65 536-BIT (65 536-WORD BY 1-BIT) DYNAMIC RAM**3. Two Methods of Chip Selection**

Since the output is not latched, $\overline{\text{CAS}}$ is not required to keep the outputs of selected chips in the matrix in a high-impedance state. This means that $\overline{\text{CAS}}$ and/or $\overline{\text{RAS}}$ can both be decoded for chip selection.

4. Extended-Page Boundary

By decoding $\overline{\text{CAS}}$, the page boundary can be extended beyond the 256 column locations in a single chip. In this case, $\overline{\text{RAS}}$ must be applied to all devices.

Page-Mode Operation

This operation allows for multiple-column addressing at the same row address, and eliminates the power dissipation associated with the negative-going edge of $\overline{\text{RAS}}$, because once the row address has been strobed, $\overline{\text{RAS}}$ is maintained. Also, the time required to strobe in the row address for the second and subsequent cycles is eliminated, thereby decreasing the access and cycle times.

Refresh

Each of the 128 rows ($A_0 \sim A_6$) of the M5K4164ANL must be refreshed every 2 ms to maintain data. The methods of refreshing for the M5K4164ANL are as follows.

1. Normal Refresh

Read cycle and Write cycle (early write, delayed write or read-modify-write) refresh the selected row as defined by the low order ($\overline{\text{RAS}}$) addresses. Any write cycle, of course, may change the state of the selected cell. Using a read, write, or read-modify-write cycle for refresh is not recommended for systems which utilize "write-OR" outputs since output bus contention will occur.

2. $\overline{\text{RAS}}$ Only Refresh

A $\overline{\text{RAS}}$ -only refresh cycle is the recommended technique for most applications to provide for data retention. A $\overline{\text{RAS}}$ -only refresh cycle maintains the output in the high-impedance state with a typical power reduction of 20% over a read or write cycle.

3. Hidden Refresh

A feature of the M5K4164ANL is that refresh cycles may be performed while maintaining valid data at the output pin by extending the $\overline{\text{CAS}}$ active time from a previous memory read cycle. This feature is referred to as hidden refresh.

Hidden refresh is performed by holding $\overline{\text{CAS}}$ at V_{IL} and taking $\overline{\text{RAS}}$ high and after a specified precharge period, executing a $\overline{\text{RAS}}$ -only cycling, but with $\overline{\text{CAS}}$ held low.

The advantage of this refresh mode is that data can be held valid at the output data port indefinitely by leaving the $\overline{\text{CAS}}$ asserted. In many applications this eliminates the need for off-chip latches.

Power Dissipation

Most of the circuitry in the M5K4164ANL is dynamic, and most of the power is dissipated when addresses are strobed. Both $\overline{\text{RAS}}$ and $\overline{\text{CAS}}$ are decoded and applied to the M5K4164ANL as chip-select in the memory system, but if $\overline{\text{RAS}}$ is decoded, all unselected devices go into stand-by independent of the $\overline{\text{CAS}}$ condition, minimizing system power dissipation.

Power Supplies

The M5K4164ANL operates on a single 5V power supply.

A wait of some 500 μ s and eight or more dummy cycles is necessary after power is applied to the device before memory operation is achieved.

M5K4164ANL-12, -15**65 536-BIT (65 536-WORD BY 1-BIT) DYNAMIC RAM****ABSOLUTE MAXIMUM RATINGS**

Symbol	Parameter	Conditions	Limits	Unit
V _{CC}	Supply voltage	With respect to V _{SS}	-1~7	V
V _I	Input voltage		-1~7	V
V _O	Output voltage		-1~7	V
I _O	Output current		50	mA
P _d	Power dissipation	T _a = 25°C	700	mW
T _{opr}	Operating free-air temperature range		0~70	°C
T _{stg}	Storage temperature range		-65~150	°C

RECOMMENDED OPERATING CONDITIONS (T_a = 0~70°C, unless otherwise noted) (Note 1)

Symbol	Parameter	Limits			Unit
		Min	Nom	Max	
V _{CC}	Supply voltage	4.5	5	5.5	V
V _{SS}	Supply voltage	0	0	0	V
V _{IH}	High-level input voltage, all inputs	2.4		6.5	V
V _{IL}	Low-level input voltage, all inputs	-2		0.8	V

Note 1. All voltage values are with respect to V_{SS}.

ELECTRICAL CHARACTERISTICS (T_a = 0~70°C, V_{CC} = 5V ± 10%, V_{SS} = 0V, unless otherwise noted) (Note 2)

Symbol	Parameter	Test conditions	Limits			Unit
			Min	Typ	Max	
V _{OH}	High-level output voltage	I _{OH} = -5mA	2.4		V _{CC}	V
V _{OL}	Low-level output voltage	I _{OL} = 4.2mA	0		0.4	V
I _{OZ}	Off-state output current	Q floating 0V ≤ V _{OUT} ≤ 5.5V	-10		10	μA
I _I	Input current	0V ≤ V _{IN} ≤ 6.5V, All other pins = 0V	-10		10	μA
I _{CC1(AV)}	Average supply current from V _{CC} , operating (Note 3, 4)	M5K4164ANL-12	R _{AS} , C _{AS} cycling		50	mA
		M5K4164ANL-15	t _{CR} = t _{CW} = min, output open		45	mA
I _{CC2}	Supply current from V _{CC} , standby	R _{AS} = V _{IH} , output open			4	mA
I _{CC3(AV)}	Average supply current from V _{CC} , refreshing (Note 3)	M5K4164ANL-12	R _{AS} cycling C _{AS} = V _{IH}		40	mA
		M5K4164ANL-15	t _{C(REF)} = min, output open		35	mA
I _{CC4(AV)}	Average supply current from V _{CC} , page mode (Note 3, 4)	M5K4164ANL-12	R _{AS} = V _{IL} , C _{AS} cycling		40	mA
		M5K4164ANL-15	t _{CPG} = min, output open		35	mA
C _{I(A)}	Input capacitance, address inputs	V _I = V _{SS} f = 1MHz V _i = 25mVrms			5	pF
C _{I(D)}	Input capacitance, data input				5	pF
C _{I(W)}	Input capacitance, write control input				7	pF
C _{I(RAS)}	Input capacitance, R _{AS} input				10	pF
C _{I(CAS)}	Input capacitance, C _{AS} input				10	pF
C _O	Output capacitance		V _O = V _{SS} , f = 1MHz, V _i = 25mVrms			7

Note 2: Current flowing into an IC is positive, out is negative.

3: I_{CC1(AV)}, I_{CC3(AV)}, and I_{CC4(AV)} are dependent on cycle rate. Maximum current is measured at the fastest cycle rate.

4: I_{CC1(AV)} and I_{CC4(AV)} are dependent on output loading. Specified values are obtained with the output open.

65 536-BIT (65 536-WORD BY 1-BIT) DYNAMIC RAM

TIMING REQUIREMENTS (For Read, Write, Read-Modify-Write, Refresh, and Page-Mode Cycle)

($T_a = 0 \sim 70^\circ\text{C}$, $V_{CC} = 5\text{V} \pm 10\%$, $V_{SS} = 0\text{V}$, unless otherwise noted, See notes 5, 6 and 7)

Symbol	Parameter	Alternative Symbol	M5K4164ANL-12		M5K4164ANL-15		Unit
			Limits		Limits		
			Min	Max	Min	Max	
t_{CRF}	Refresh cycle time	t_{REF}		2		2	ms
$t_W(\text{RASH})$	$\overline{\text{RAS}}$ high pulse width	t_{RP}	90		100		ns
$t_W(\text{RASL})$	$\overline{\text{RAS}}$ low pulse width	t_{RAS}	120	10000	150	10000	ns
$t_W(\text{CASL})$	$\overline{\text{CAS}}$ low pulse width	t_{CAS}	60	∞	75	∞	ns
$t_W(\text{CASH})$	$\overline{\text{CAS}}$ high pulse width (Note 8)	t_{CPN}	30		35		ns
$t_h(\text{RAS-CAS})$	$\overline{\text{CAS}}$ hold time after $\overline{\text{RAS}}$	t_{CSH}	120		150		ns
$t_h(\text{CAS-RAS})$	$\overline{\text{RAS}}$ hold time after $\overline{\text{CAS}}$	t_{RSH}	60		75		ns
$t_d(\text{CAS-RAS})$	Delay time, $\overline{\text{CAS}}$ to $\overline{\text{RAS}}$ (Note 9)	t_{CRP}	-20		-20		ns
$t_d(\text{RAS-CAS})$	Delay time, $\overline{\text{RAS}}$ to $\overline{\text{CAS}}$ (Note 10)	t_{RCD}	25	60	30	75	ns
$t_{SU}(\text{RA-RAS})$	Row address setup time before $\overline{\text{RAS}}$	t_{ASR}	0		0		ns
$t_{SU}(\text{CA-CAS})$	Column address setup time before $\overline{\text{CAS}}$	t_{ASC}	0		0		ns
$t_h(\text{RAS-RA})$	Row address hold time after $\overline{\text{RAS}}$	t_{RAH}	15		20		ns
$t_h(\text{CAS-CA})$	Column address hold time after $\overline{\text{CAS}}$	t_{CAH}	20		25		ns
$t_h(\text{RAS-CA})$	Column address hold time after $\overline{\text{RAS}}$	t_{AR}	90		95		ns
t_{THL}	Transition time	t_T	3	35	3	50	ns
t_{TLH}							

Note 5: An initial pause of 500 μs is required after power-up followed by any eight $\overline{\text{RAS}}$ or $\overline{\text{RAS}}/\overline{\text{CAS}}$ cycles before proper device operation is achieved.

6: The switching characteristics are defined as $t_{THL} = t_{TLH} = 5\text{ns}$.

7: Reference levels of input signals are $V_{IH\text{ min}}$ and $V_{IL\text{ max}}$. Reference levels for transition time are also between V_{IH} and V_{IL} .

8: Except for page-mode.

9: $t_d(\text{CAS-RAS})$ requirement is only applicable for $\overline{\text{RAS}}/\overline{\text{CAS}}$ cycles preceded by a $\overline{\text{CAS}}$ only cycle (i.e., For systems where $\overline{\text{CAS}}$ has not been decoded with $\overline{\text{RAS}}$.)

10: Operation within the $t_d(\text{RAS-CAS})$ max limit insures that $t_a(\text{RAS})$ max can be met. $t_d(\text{RAS-CAS})$ max is specified reference point only, if

$t_d(\text{RAS-CAS})$ is greater than the specified $t_d(\text{RAS-CAS})$ max limit, then access time is controlled exclusively by $t_a(\text{CAS})$.

$t_d(\text{RAS-CAS})\text{ min} = t_h(\text{RAS-RA})\text{ min} + 2t_{THL}(t_{TLH}) + t_{SU}(\text{CA-CAS})\text{ min}$.

SWITCHING CHARACTERISTICS ($T_a = 0 \sim 70^\circ\text{C}$, $V_{CC} = 5\text{V} \pm 10\%$, $V_{SS} = 0\text{V}$, unless otherwise noted)

Read Cycle

Symbol	Parameter	Alternative Symbol	M5K4164ANL-12		M5K4164ANL-15		Unit
			Limits		Limits		
			Min	Max	Min	Max	
t_{CR}	Read cycle time	t_{RC}	220		260		ns
$t_{SU}(\text{R-CAS})$	Read setup time before $\overline{\text{CAS}}$	t_{RCS}	0		0		ns
$t_h(\text{CAS-R})$	Read hold time after $\overline{\text{CAS}}$ (Note 11)	t_{RCH}	0		0		ns
$t_h(\text{RAS-R})$	Read hold time after $\overline{\text{RAS}}$ (Note 11)	t_{RRH}	10		20		ns
$t_{DIS}(\text{CAS})$	Output disable time (Note 12)	t_{OFF}	0	35	0	40	ns
$t_a(\text{CAS})$	$\overline{\text{CAS}}$ access time (Note 13)	t_{CAC}		60		75	ns
$t_a(\text{RAS})$	$\overline{\text{RAS}}$ access time (Note 14)	t_{RAC}		120		150	ns

Note 11: Either $t_h(\text{RAS-R})$ or $t_h(\text{CAS-R})$ must be satisfied for a read cycle.

Note 12: $t_{DIS}(\text{CAS})$ max defines the time at which the output achieves the open circuit condition and is not reference to V_{OH} or V_{OL} .

Note 13: This is the value when $t_d(\text{RAS-CAS}) \geq t_d(\text{RAS-CAS})$ max. Test conditions: Load = 2T TL, $C_L = 100\text{pF}$

Note 14: This is the value when $t_d(\text{RAS-CAS}) < t_d(\text{RAS-CAS})$ max. When $t_d(\text{RAS-CAS}) \geq t_d(\text{RAS-CAS})$ max, $t_a(\text{RAS})$ will increase by the amount that

$t_d(\text{RAS-CAS})$ exceeds the value shown. Test conditions: Load = 2T TL, $C_L = 100\text{pF}$

Write Cycle

Symbol	Parameter	Alternative Symbol	M5K4164ANL-12		M5K4164ANL-15		Unit
			Limits		Limits		
			Min	Max	Min	Max	
t_{CW}	Write cycle time	t_{RC}	220		260		ns
$t_{SU}(\text{W-CAS})$	Write setup time before $\overline{\text{CAS}}$ (Note 17)	t_{WCS}	-5		-5		ns
$t_h(\text{CAS-W})$	Write hold time after $\overline{\text{CAS}}$	t_{WCH}	40		45		ns
$t_h(\text{RAS-W})$	Write hold time after $\overline{\text{RAS}}$	t_{WCR}	90		95		ns
$t_h(\text{W-RAS})$	$\overline{\text{RAS}}$ hold time after write	t_{RWL}	40		45		ns
$t_h(\text{W-CAS})$	$\overline{\text{CAS}}$ hold time after write	t_{CWL}	40		45		ns
$t_W(\text{W})$	Write pulse width	t_{WP}	40		45		ns
$t_{SU}(\text{D-CAS})$	Data-in setup time before $\overline{\text{CAS}}$	t_{DS}	0		0		ns
$t_h(\text{CAS-D})$	Data-in hold time after $\overline{\text{CAS}}$	t_{DH}	40		45		ns
$t_h(\text{RAS-D})$	Data-in hold time after $\overline{\text{RAS}}$	t_{DHR}	90		95		ns

65 536-BIT (65 536-WORD BY 1-BIT) DYNAMIC RAM

Read-Write and Read-Modify-Write Cycles

Symbol	Parameter	Alternative Symbol	M5K4164ANL-12		M5K4164ANL-15		Unit
			Limits		Limits		
			Min	Max	Min	Max	
t _{CRW}	Read-write cycle time (Note 15)	t _{RWC}	245		280		ns
t _{CRMW}	Read-modify-write cycle time (Note 16)	t _{RMWC}	265		310		ns
t _{h (W-RAS)}	$\overline{\text{RAS}}$ hold time after write	t _{RWL}	40		45		ns
t _{h (W-CAS)}	$\overline{\text{CAS}}$ hold time after write	t _{CWL}	40		45		ns
t _{w (W)}	Write pulse width	t _{WP}	40		45		ns
t _{su (R-CAS)}	Read setup time before $\overline{\text{CAS}}$	t _{RCS}	0		0		ns
t _{d (RAS-W)}	Delay time, $\overline{\text{RAS}}$ to write (Note 17)	t _{RWD}	100		120		ns
t _{d (CAS-W)}	Delay time, $\overline{\text{CAS}}$ to write (Note 17)	t _{CWD}	40		60		ns
t _{su (D-W)}	Data-in setup time before write	t _{DS}	0		0		ns
t _{h (W-D)}	Data-in hold time after write	t _{DH}	40		45		ns
t _{dis (CAS)}	Output disable time	t _{OFF}	0	35	0	40	ns
t _{a (CAS)}	$\overline{\text{CAS}}$ access time (Note 13)	t _{CAC}		60		75	ns
t _{a (RAS)}	$\overline{\text{RAS}}$ access time (Note 14)	t _{RAC}		120		150	ns

Note 15: t_{CRW min} is defined as t_{CRW min} = t_{d (RAS-W)} + t_{h (W-RAS)} + t_{w (RASH)} + 3t_{TLH (t_{THL})}

16: t_{CRMW min} is defined as t_{CRMW min} = t_{a (RAS)max} + t_{h (W-RAS)} + t_{w (RASH)} + 3t_{TLH (t_{THL})}

17: t_{su (W-CAS)}, t_{d (RAS-W)}, and t_{d (CAS-W)} do not define the limits of operation, but are included as electrical characteristics only.

When t_{su (W-CAS)} ≥ t_{su (W-CAS)min}, an early-write cycle is performed, and the data output keeps the high-impedance state.

When t_{d (RAS-W)} ≥ t_{d (RAS-W)min}, and t_{d (CAS-W)} ≥ t_{su (W-CAS)min} a read-write cycle is performed, and the data of the selected address will be read out on the data output.

For all conditions other than those described above, the condition of data output (at access time and until $\overline{\text{CAS}}$ goes back to V_{IH}) is not defined.

Page-Mode Cycle

Symbol	Parameter	Alternative Symbol	M5K4164ANL-12		M5K4164ANL-15		Unit
			Limits		Limits		
			Min	Max	Min	Max	
t _{C PGR}	Page-mode read cycle time	t _{PC}	140		140		ns
t _{C PGW}	Page-Mode write cycle time	t _{PC}	140		145		ns
t _{C PGRW}	Page-Mode read-write cycle time	—	150		180		ns
t _{C PGRMW}	Page-Mode read-modify-write cycle time	—	170		195		ns
t _{w (CASH)}	$\overline{\text{CAS}}$ high pulse width	t _{CP}	55		60		ns

65 536-BIT (65 536-WORD BY 1-BIT) DYNAMIC RAM

TIMING DIAGRAMS (Note 18)

Read Cycle

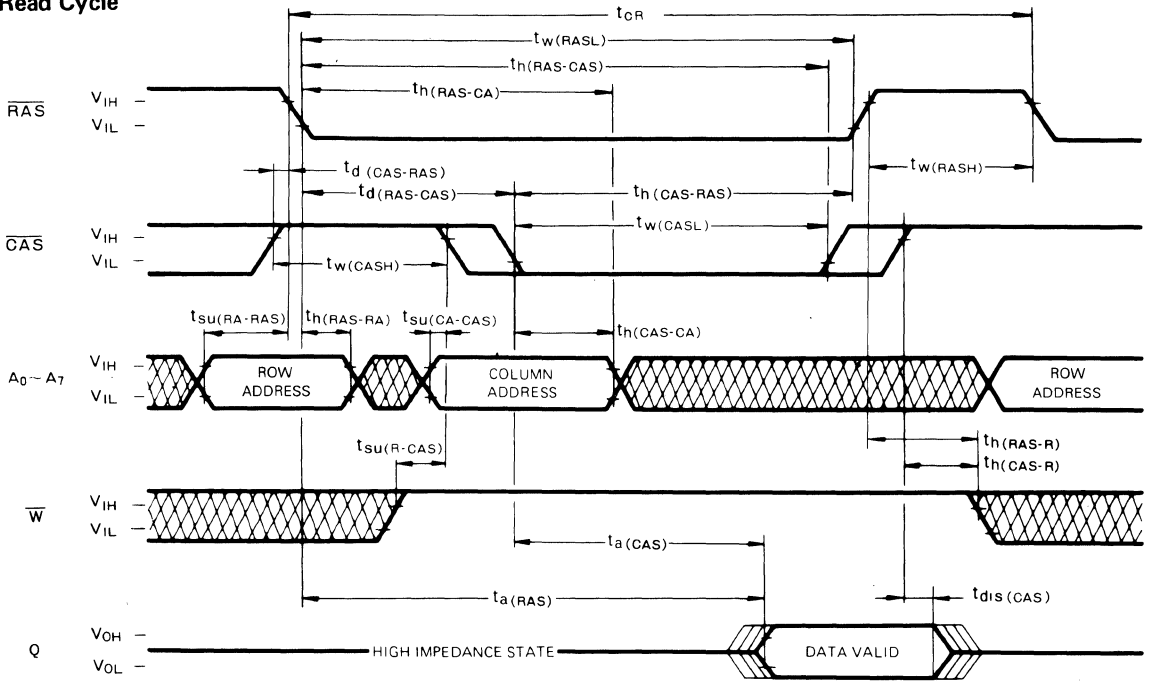

Write Cycle (Early Write)

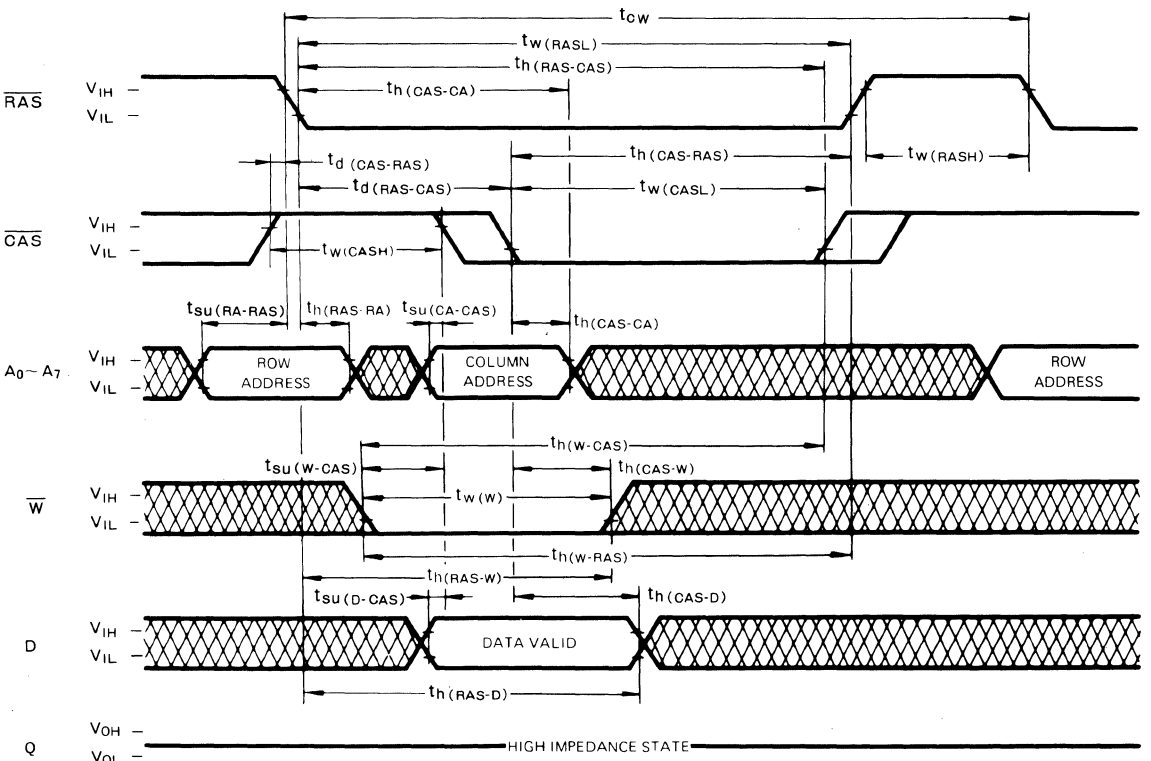

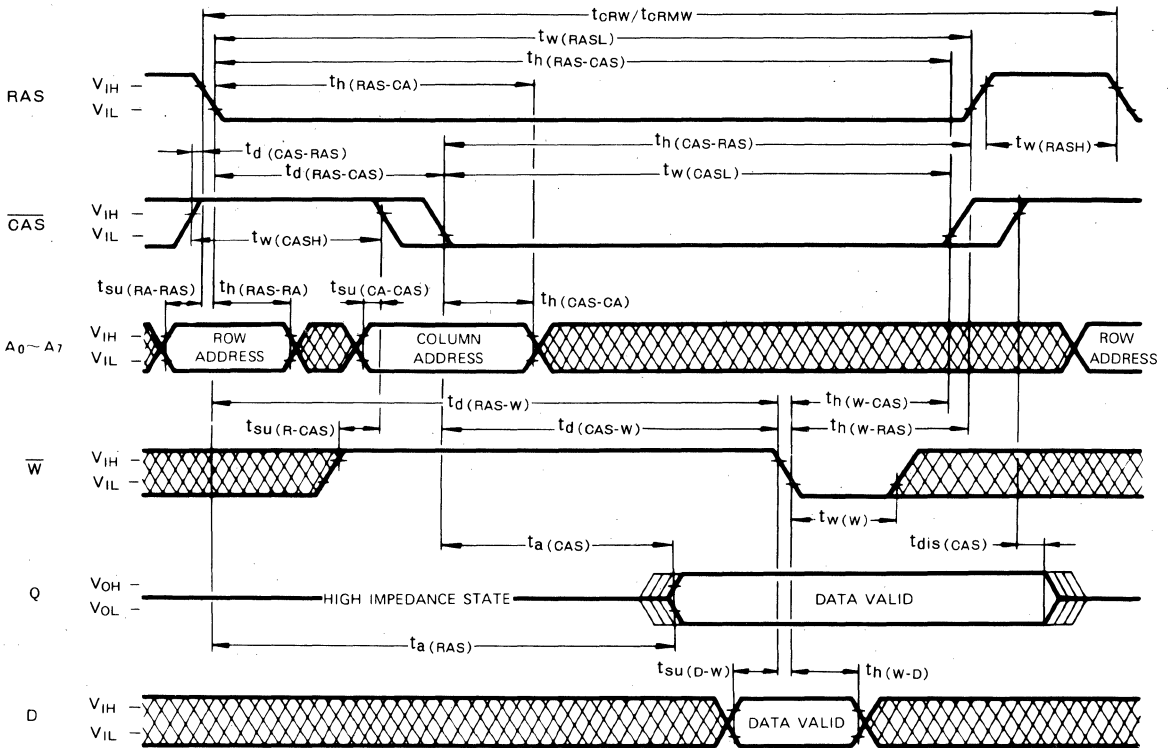

65 536-BIT (65 536-WORD BY 1-BIT) DYNAMIC RAM

Read-Write and Read-Modify-Write Cycles

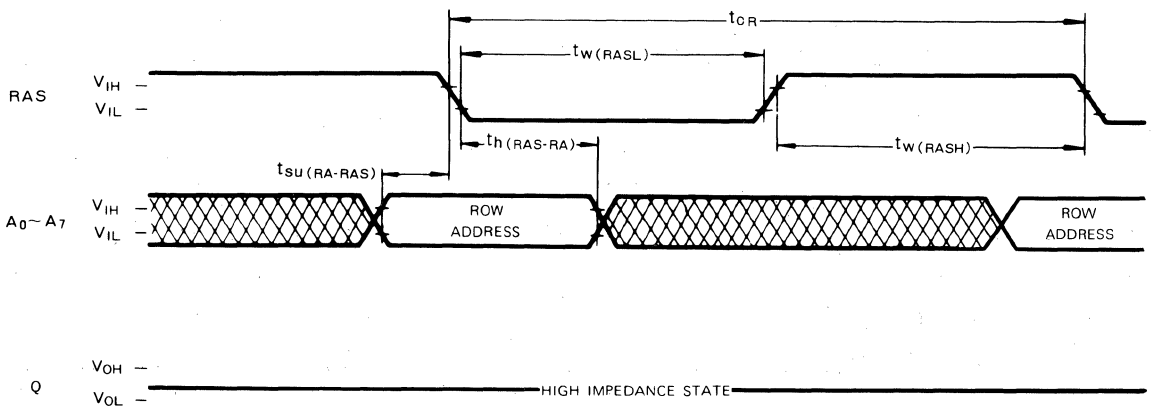

RAS-Only Refresh Cycle (Note 19)



Note 18  Indicates the don't care input

 The center-line indicates the high-impedance state

Note 19 $\overline{CAS} = V_{IH}$, \overline{W} , D = don't care.
A7 may be V_{IH} or V_{IL} .

65 536-BIT (65 536-WORD BY 1-BIT) DYNAMIC RAM

Page-Mode Read Cycle

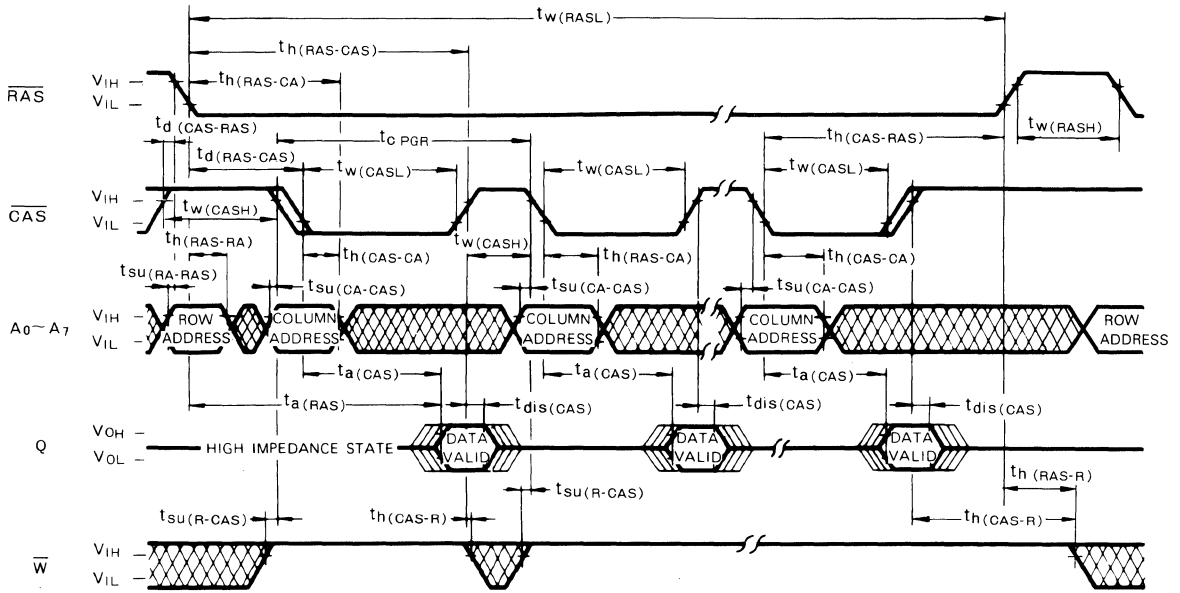

Page-Mode Write Cycle

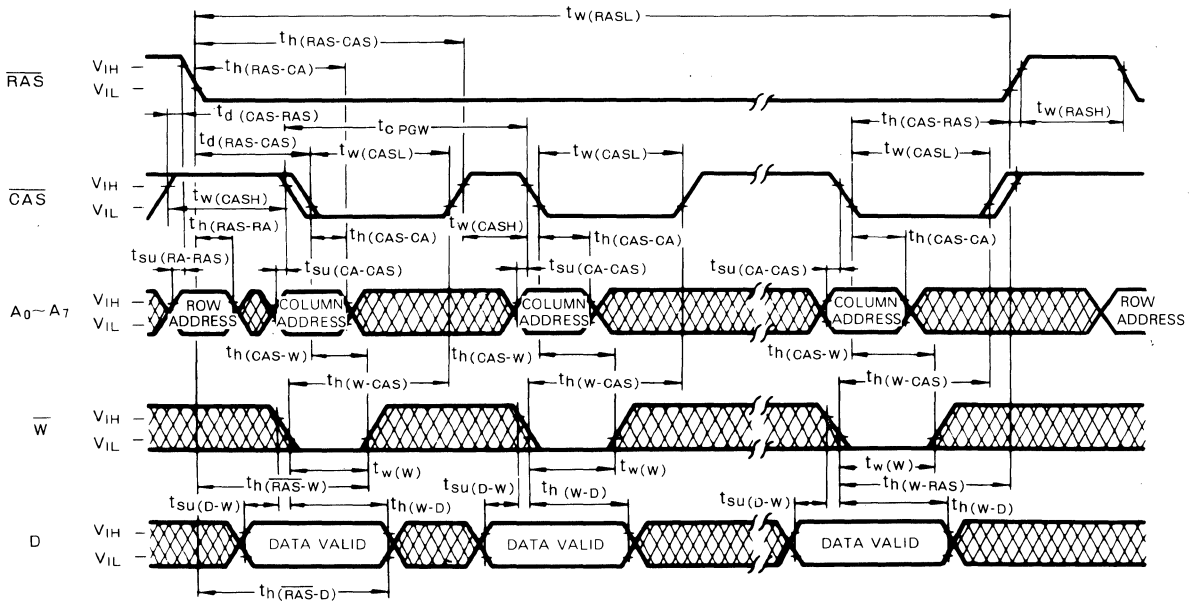

65 536-BIT (65 536-WORD BY 1-BIT) DYNAMIC RAM

Hidden Refresh Cycle

