

# M61084FP

## PREAMPLIFIER WITH PHOTODETECTOR FOR OPTICAL PICKUP

### DESCRIPTION

The M61084FP is a semiconductor integrated circuit developed for DVD and CD-ROM (8 times speed) players. The IC is housed in a 12-pin clear molded plastic package and contains 8 preamplifiers with divided photodetectors.

### FEATURES

- 8 amplifiers with divided photodetectors
- Using small package ( 5.0X4.0X1.5 mm )
- For differential push-pull technique and single beam phase difference technique
- High Band preamplifier circuit (DC-20MHz)
- For red reys laser diode (ex.  $\lambda = 635 \text{ nm}$ )

### APPLICATION

DVD , CD-ROM etc.

### RECOMMENDED OPERATING CONDITIONS

Supply voltage •••••••••• 4.5V to 5.5V

Rated supply voltage •••••• 5.0V

### PIN CONFIGURATION

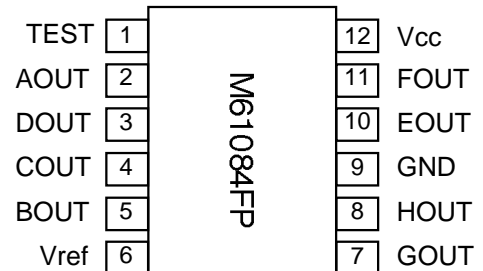

Outline 12C2E

### BLOCK DIAGRAM

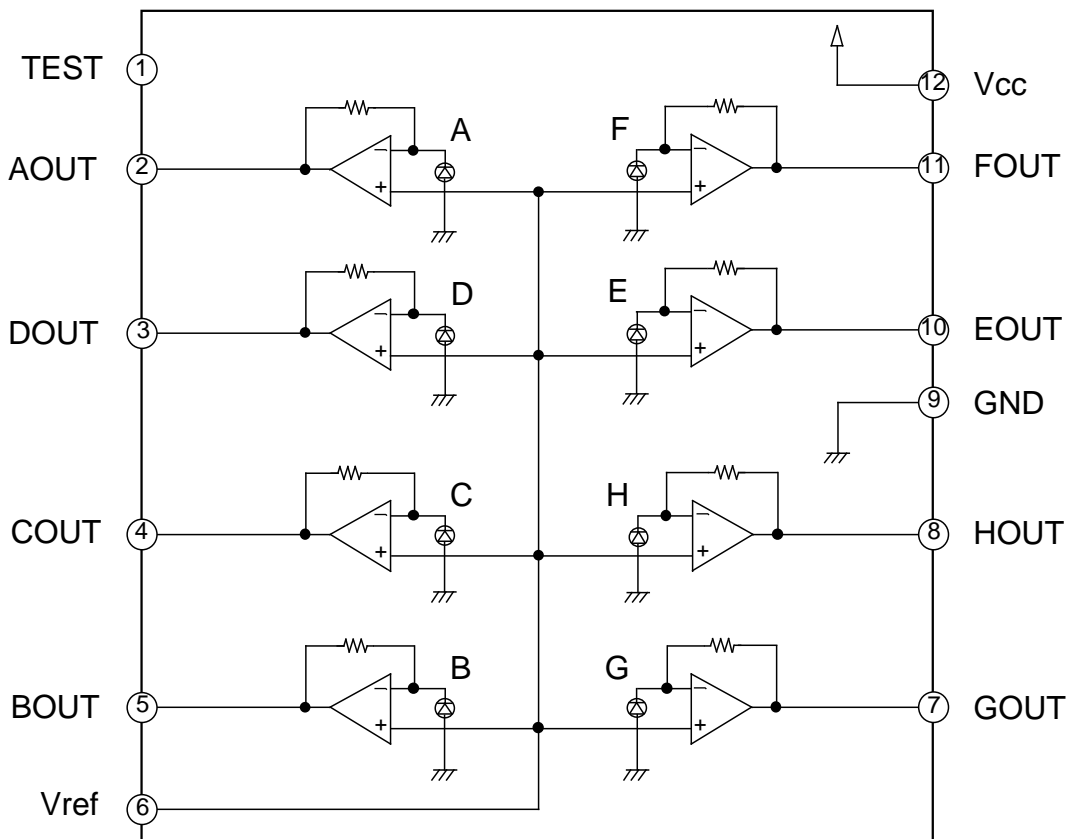

# M61084FP

## PREAMPLIFIER WITH PHOTODETECTOR FOR OPTICAL PICKUP

ABSOLUTE MAXIMUM RATINGS (Ta=25°C,unless otherwise noted)

Symbol	Parameter	Rating	Unit
Vcc	Supply voltage	6.0	V
Pd	Power dissipation (Ta≤25°C)	250	mW
Topr	Operating temperature	-20 to +70	°C
Tstg	Storage temperature	-40 to +100	°C

### TEST CIRCUIT

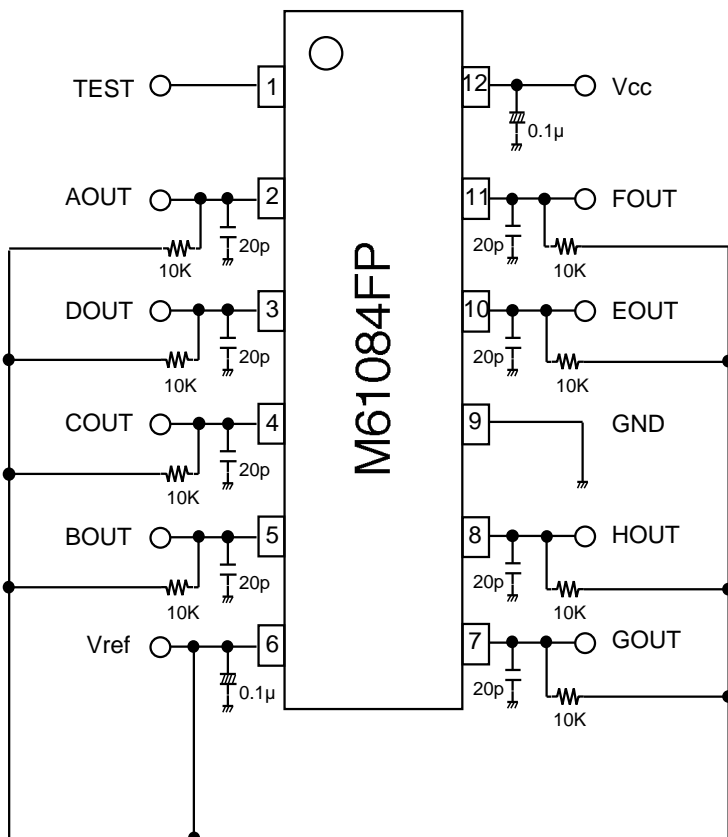

Units Resistance : Ω  
 Capacitance : F

### THERMAL DERATING (MAXIMUM RATINGS)

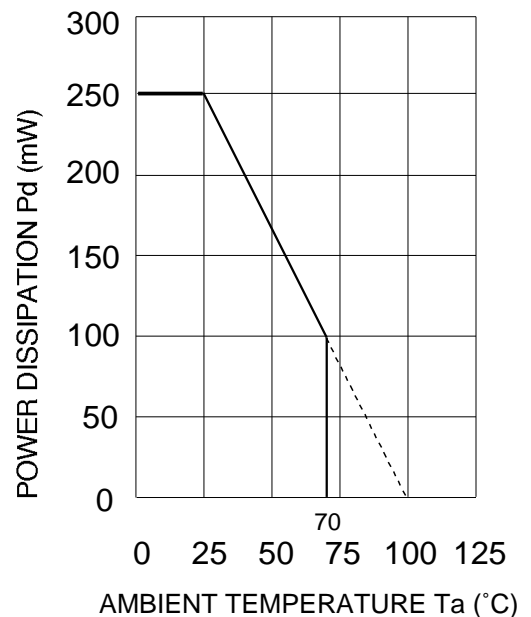

\*Please set the condenser connected to Vcc and Vc near the pin. (Within 10mm)



**M61084FP****PREAMPLIFIER WITH PHOTODETECTOR FOR OPTICAL PICKUP**

ELECTRICAL CHARACTERISTICS (VCC=5.0V, Ta=25°C, unless otherwise noted)

Symbol	Parameter	Test conditions	Limits			Unit
			Min	Typ	Max	
I <sub>CC</sub>	Circuit current	In the dark	3.5	5.0	6.5	mA
V <sub>O</sub>	Output voltage	P <sub>O</sub> =10μW λ=635nm Output A to D without offset voltage	210	270	330	mV
		P <sub>O</sub> =10μW λ=635nm Output E to H without offset voltage	400	500	600	mV
V <sub>OFF</sub>	Output offset voltage	In the dark Output A to H	-15	0	+15	mV
ΔV <sub>OFF</sub>	Delta output offset voltage	In the dark (A+B) - (C+D)	-15	0	+15	mV
		In the dark (A+D) - (B+C)	-15	0	+15	
		In the dark E - F	-15	0	+15	
		In the dark G - H	-15	0	+15	
V <sub>OMAX</sub>	Maximum Output voltage	Output A to H maximum voltage at V <sub>CC</sub> =5.0 v	3.5	-	-	V
f <sub>c</sub>	Frequency characteristic	P <sub>O</sub> =10μW/cell λ=635nm 30%modulation 3 dB down Output A to D	15	20	-	MHz
		P <sub>O</sub> =10μW/cell λ=635nm 30%modulation 3 dBdown Output E to H	1.0	1.5	-	
V <sub>NO</sub>	Output noise voltage	Output A to D (at f=5MHz)	-	-80	-74	dBm
R	Optical sensitivity on SPD	λ=635nm Output A to H	-	0.3	-	A/W



# M61084FP

## PREAMPLIFIER WITH PHOTODETECTOR FOR OPTICAL PICKUP

### PD SIZE (TYPICAL)

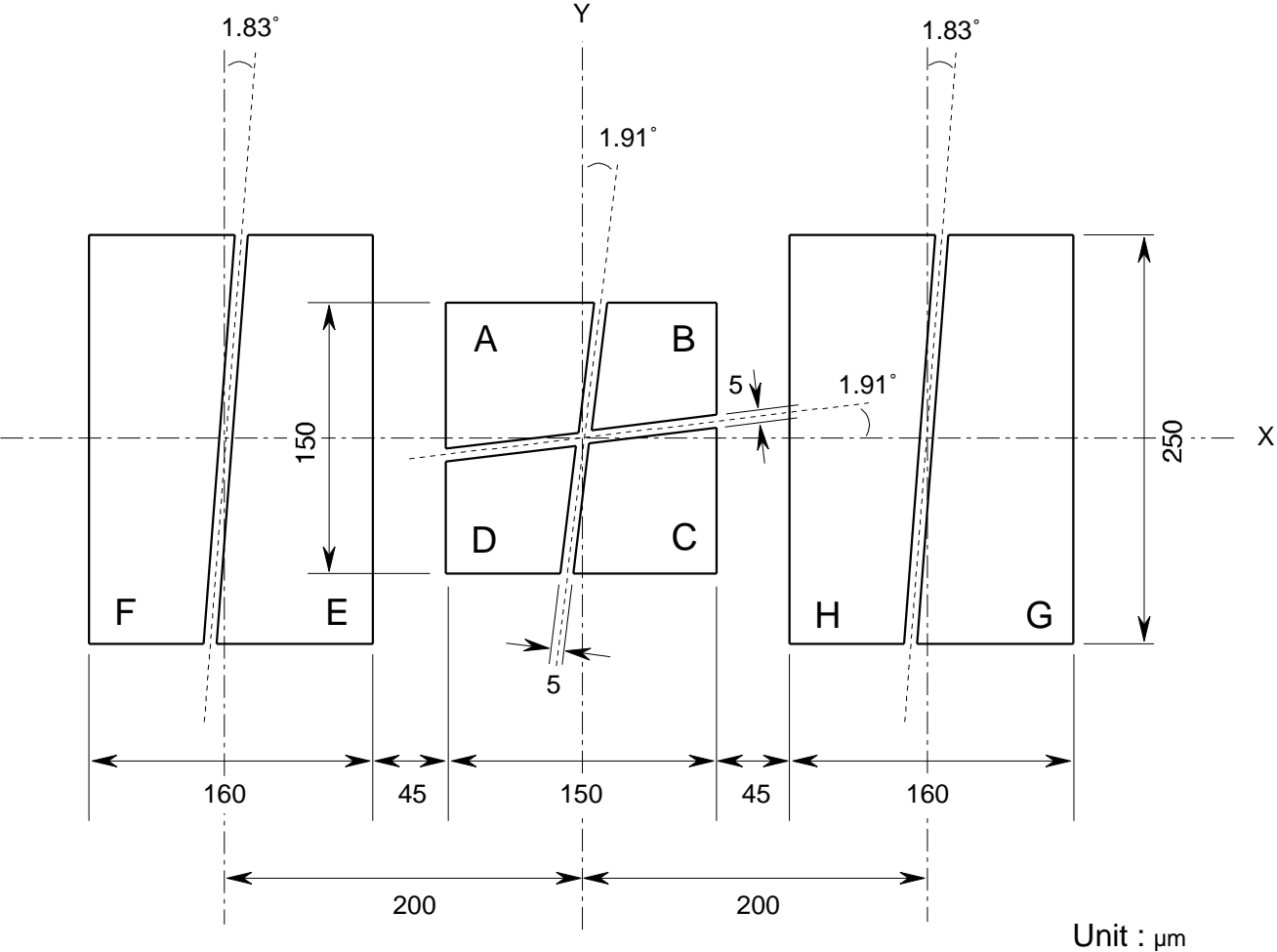

Unit :  $\mu\text{m}$

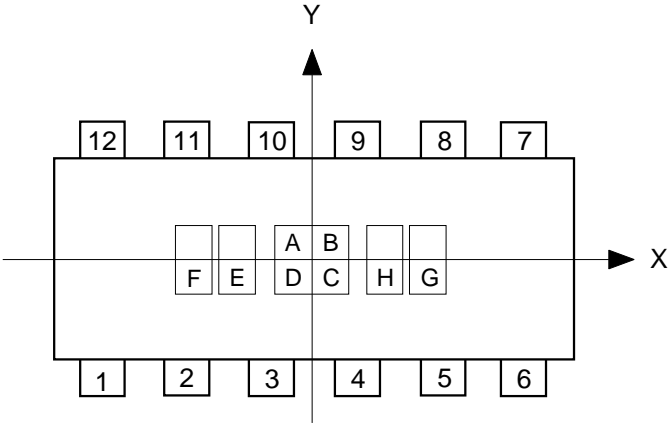

- Note )
- A public difference from the SPD center and the flame .....  $\pm 0.2\text{mm}$
  - A public difference from the center of the flame of molded package .....  $\pm 0.2\text{mm}$
  - A public difference from the center of SPD and the center of molded package .....  $\pm 0.4\text{mm}$
  - The rotation deviation of SPD toward the flame .....  $\pm 3$  degree

# M61084FP

## PREAMPLIFIER WITH PHOTODETECTOR FOR OPTICAL PICKUP

### Note regarding these materials

- These materials are intended as reference to assist our customers in the selection of the Mitsubishi semiconductor product best suited to the customer's application; they do not convey any license under any intellectual property rights, or any other rights, belonging to Mitsubishi Electric Corporation or a third party.
- Mitsubishi Electric Corporation assumes no responsibility for any damage, or infringement of any third-party's right, originating in the use of any product data, diagrams, charts or circuit application examples contained in these materials.
- All information contained in these materials, including product data, diagrams and charts, represent information on products at the time of publication of these materials, and are subject to change by Mitsubishi Electric Corporation without notice due to product improvements or other reasons. It is therefore recommended that customers contact Mitsubishi Electric Corporation or an authorized Mitsubishi Semiconductor product distributor for the latest product information before purchasing a product listed herein.
- Mitsubishi Electric Corporation semiconductors are not designed or manufactured for use in a device or system that is used under circumstances in which human life is potentially at stake. Please contact Mitsubishi Electric Corporation or an authorized Mitsubishi Semiconductor product distributor when considering the use of a product contained herein for special applications, such as apparatus or systems for transportation, vehicular, medical, aerospace, nuclear repeater use.
- The prior written approval of Mitsubishi Electric Corporation is necessary to reprint or reproduce in whole or in part these materials.
- If these products or technologies are subject to the Japanese export control restrictions, they must be exported under license from the Japanese government and cannot be imported into a country other than the approved destination. Any diversion or reexport contrary to the export control laws and regulations of Japan and/or the country of destination is prohibited.
- Please contact Mitsubishi Electric Corporation or an authorized Mitsubishi Semiconductor product distributor for further details on these materials or the products contained therein.

