

PRELIMINARY
 Notice: This is not a final specification.
 some parametric limits are subject to change.

MITSUBISHI SOUND PROCESSORS
M61511FP
 AUDIO SIGNAL PROCESSOR

6ch Electric Volume with 10 Input Selector

APPLICATION

AV Amp, Receiver, Mini Compo etc.

FEATURE

- 6ch Independent Electric Volume with High Voltage Transistor
 (97 Step ; 0~-95dB/1dB Step, -∞ , Maximum Input Voltage 4Vrms)
- 10 Input Selector
- Discrete 5.1ch Analog Input Switch(2 Lines)
- 4 Lines REC Output(Both Lch and Rch)
- Input Gain Control(0/6/12dB)
- Selector Output ATT(-6dB) [ON/OFF]
- 3 Lines Micro_Computer Interface

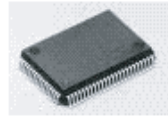

OUTLINE 80P6N
 0.8mm pitch QFP
 (20.0x14.0x2.8mm)

RECOMMENDED OPERATING CONDITION

Supply Voltage Range AVCC,AVSS= ±4.5V ~ ±7.5V DVDD=2.7V~5.5V

SYSTEM BLOCK DIAGRAM

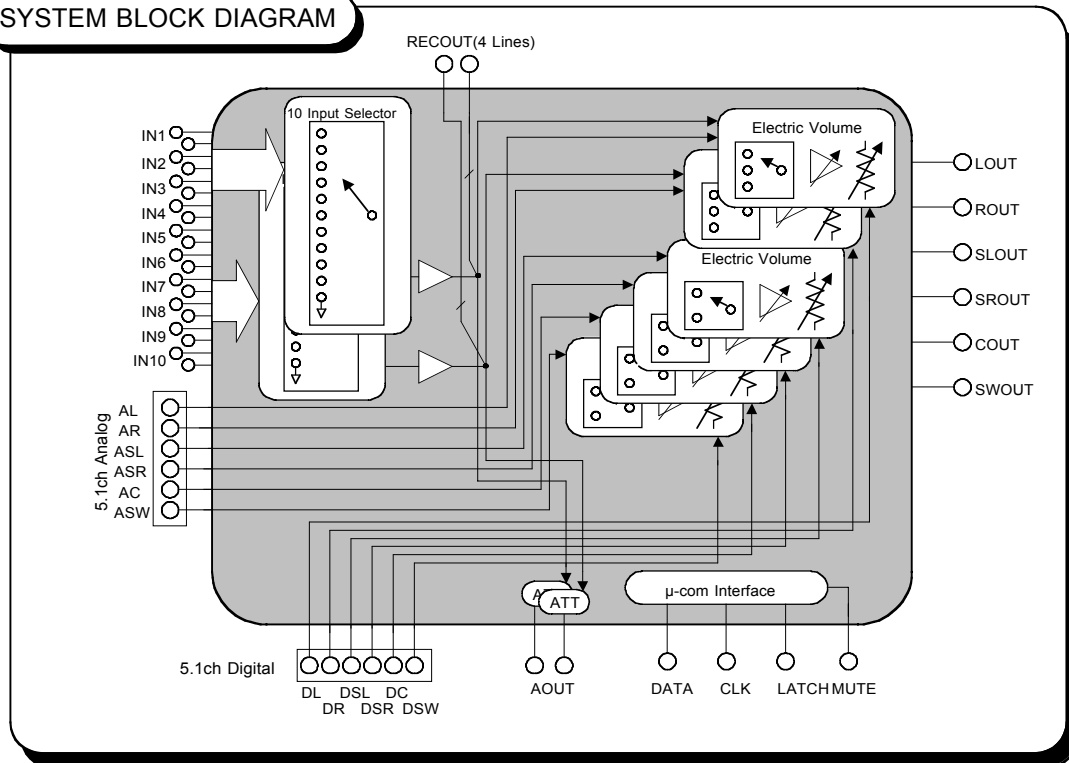

PRELIMINARY
 Notice: This is not a final specification.
 some parametric limits are subject to change.

MITSUBISHI SOUND PROCESSORS
M61511FP
 AUDIO SIGNAL PROCESSOR

BLOCK DIAGRAM AND PIN ASSIN

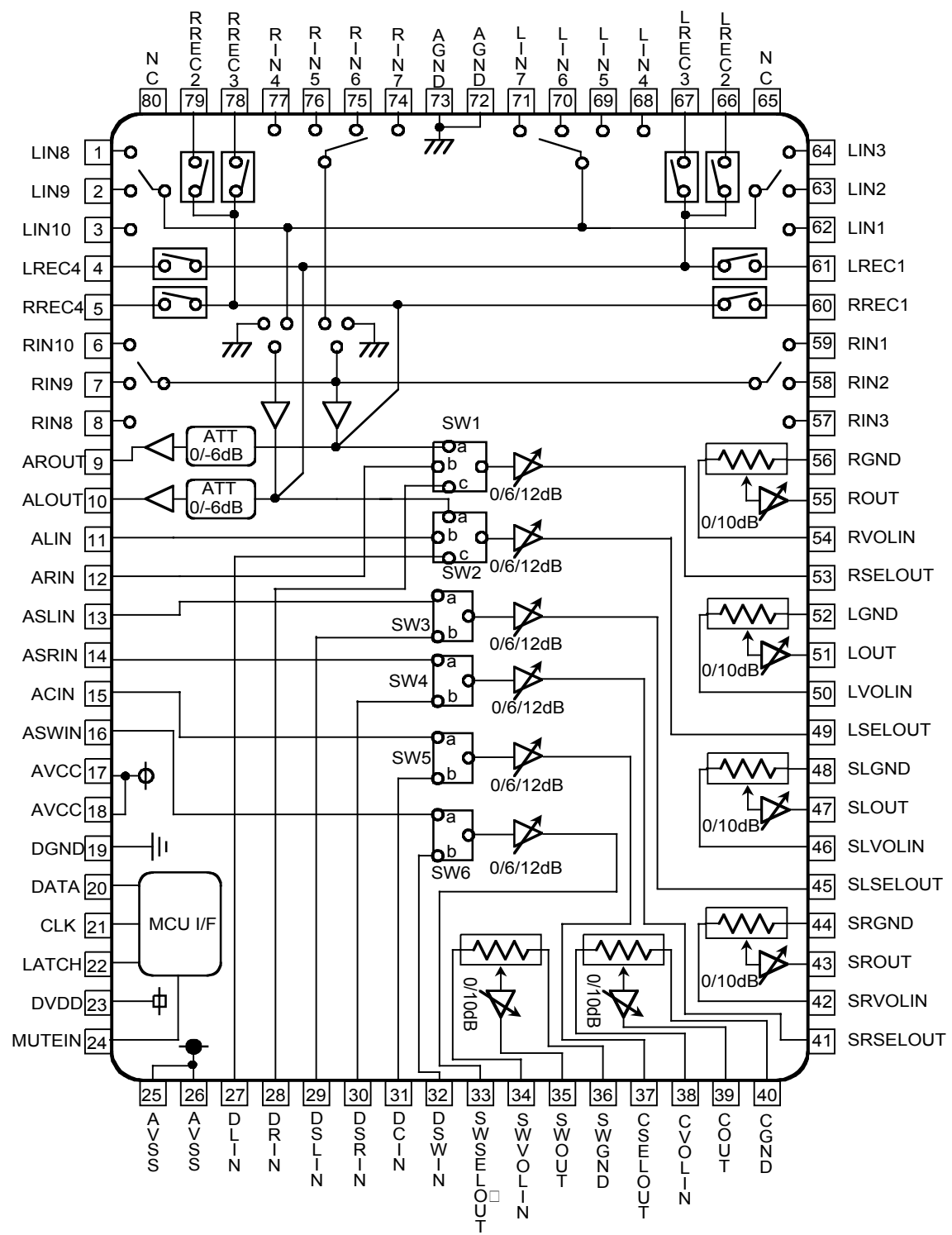

PRELIMINARY
 Notice: This is not a final specification.
 some parametric limits are subject to change.

MITSUBISHI SOUND PROCESSORS
M61511FP
 AUDIO SIGNAL PROCESSOR

ABSOLUTE MAXIMUM RATINGS

Symbol	Parameter	Condition	Limits	Unit
AVCC,AVSS	Analog supply voltag		±7.8	V
DVDD	Digital supply voltage		6.0	V
Pd	Power dissipation	Ta≤25°C	1250	mW
K	Thermal derating	Ta>25°C	12.5	mW/°C
Topr	Operating temperature		-20 ~ +55	°C
Tstg	Storage temperatur		-40 ~ +125	°C

Thermal Derating

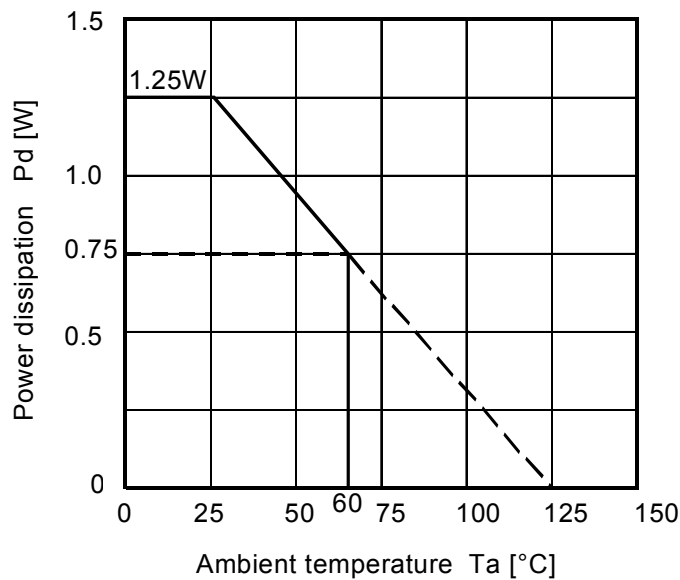

PRELIMINARY
 Notice: This is not a final specification.
 some parametric limits are subject to change.

MITSUBISHI SOUND PROCESSORS
M61511FP
 AUDIO SIGNAL PROCESSOR

RECOMMENDED OPERATING CONDITION

(Ta=25°C unless otherwise noted)

Item	Symbol	Condition	Range			Unit
			MIN	TYP	MAX	
Analog plus supply voltage	AVCC	Cf 1)	4.5	7.0	7.5	V
Analog minus supply voltage	AVSS	Cf 1)	-7.5	-7.0	-4.5	V
Digital supply voltage	DVDD	DVDD ≤ AVCC	2.7	5.0	5.5	V
Logic "H" Level Input Voltage	VIH		0.8×DVDD	-	DVDD	V
Logic "L" Level Input Voltage	VIL		DGND	-	0.2×DVDD	V

Cf 1) Please apply AVCC at first, then apply AVSS, and apply DVDD at last.

DATA AND CLOCK

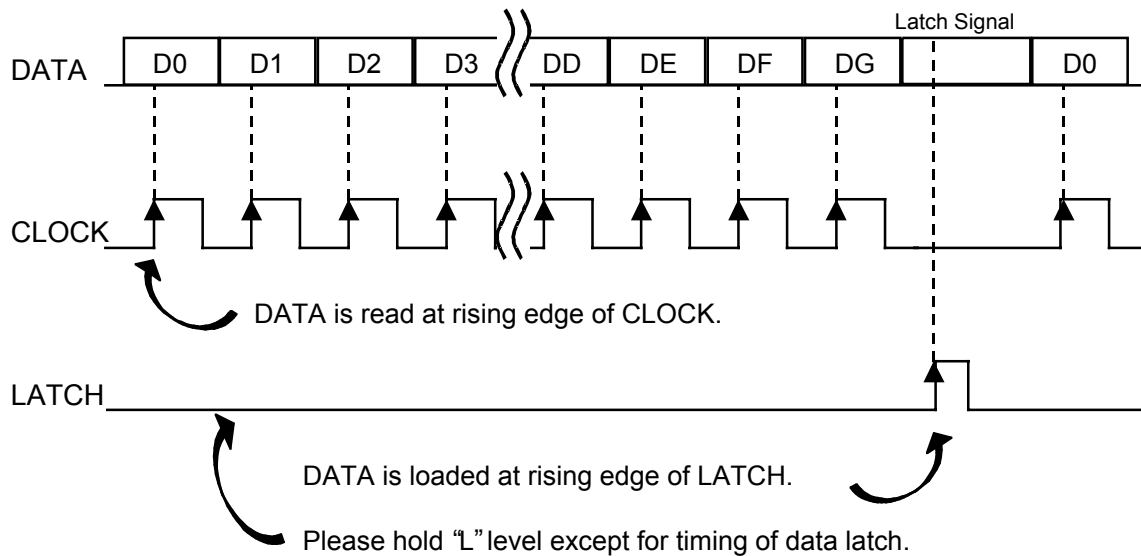

PRELIMINARY
 Notice: This is not a final specification.
 some parametric limits are subject to change.

MITSUBISHI SOUND PROCESSORS
M61511FP
 AUDIO SIGNAL PROCESSOR

CLOCK, DATA, LATCH TIMING

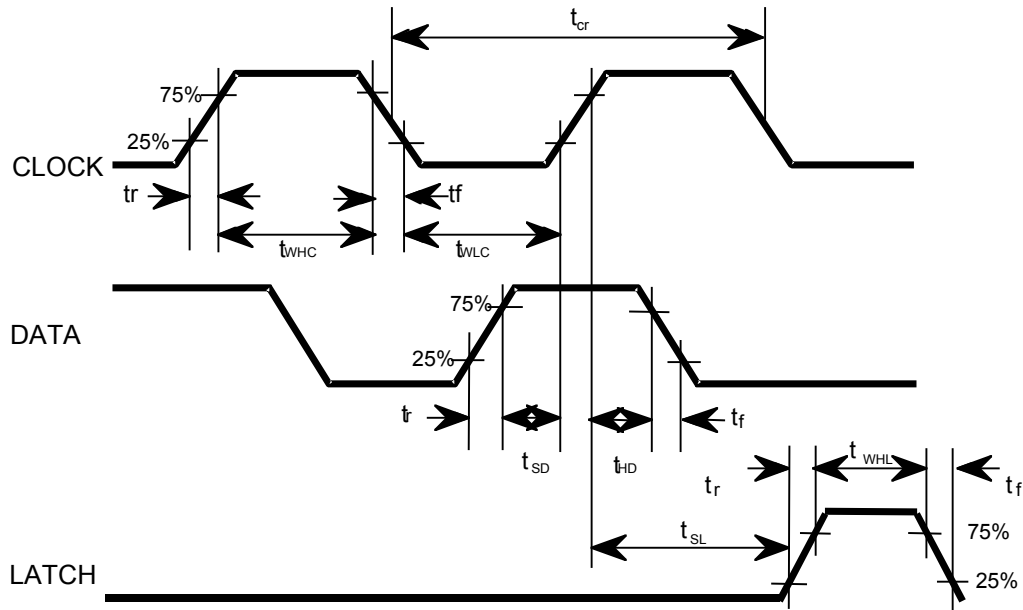

BUS LINE TIMING SPECIFICATION

SYMBOL	ITEM	SPECIFICATION			UNIT
		Min	typ	Max	
t_{cr}	Cycle time of CLOCK	4	-	-	μsec
t_{wHC}	Pulse width of CLOCK ("H" Level)	1.6	-	-	
t_{wLC}	Pulse width of CLOCK ("L" Level)	1.6	-	-	
t_r	Rise time of CLOCK, DATA, LATCH	-	-	0.4	
t_f	Fall time of CLOCK, DATA, LATCH	-	-	0.4	
t_{SD}	Set up time of DATA	0.8	-	-	
t_{HD}	Hold time of DATA	0.8	-	-	
t_{SL}	Set-up time of LATCH	1	-	-	
t_{WHL}	Pulse width of LATCH	1.6	-	-	

PRELIMINARY
 Notice: This is not a final specification.
 some parametric limits are subject to change.

MITSUBISHI SOUND PROCESSORS
M61511FP
 AUDIO SIGNAL PROCESSOR

DATA INPUT FORMAT

Please set all data of five input formats when every power supply is applied.

← Input direction

(0)																
D00	D10	D20	D30	D40	D50	D60	D70	D80	D90	DA0	DB0	DC0	DD0	DE0	DF0	DG0
Master Volume Lch Refer Setting Code (7)							Master Volume Rch Refer Setting Code (7)					0	0	0		
(1)																
D01	D11	D21	D31	D41	D51	D61	D71	D81	D91	DA1	DB1	DC1	DD1	DE1	DF1	DG1
Master Volume SLch Refer Setting Code (7)							Master Volume SRch Refer Setting Code (7)					0	1	0		
(2)																
D02	D12	D22	D32	D42	D52	D62	D72	D82	D92	DA2	DB2	DC2	DD2	DE2	DF2	DG2
Master Volume Cch Refer Setting Code (7)							Master Volume SWch Refer Setting Code (7)					0	1	1		
(3)																
D03	D13	D23	D33	D43	D53	D63	D73	D83	D93	DA3	DB3	DC3	DD3	DE3	DF3	DG3
Input Gain Lch 00,11:0dB 01:6dB 10:12dB	Input Gain Rch 00,11:0dB 01:6dB 10:12dB	Input Gain SLch 00,11:0dB 01:6dB 10:12dB	Input Gain SRch 00,11:0dB 01:6dB 10:12dB	Input Gain Cch 00,11:0dB 01:6dB 10:12dB	Input Gain SWch 00,11:0dB 01:6dB 10:12dB	Selector Output ATT 0:0dB 1:-6dB	Volume Mute (Cf 1) 0:OFF 1:ON	1	0	0						
(4)																
D04	D14	D24	D34	D44	D54	D64	D74	D84	D94	DA4	DB4	DC4	DD4	DE4	DF4	DG4
Input Selector Refer Setting Code (5)				5.1ch Input SW Refer Setting Code (6)	REC1 0:OFF 1:ON	REC2 0:OFF 1:ON	REC3 0:OFF 1:ON	REC4 0:OFF 1:ON	Output Gain 0:0dB 1:10dB	0	0	0	1	1	0	

(5) Input Selector Setting Code

No guarantee except for these code.

SELECTOR	D04	D14	D24	D34
IN1	0	0	0	0
IN2	1	0	0	0
IN3	0	1	0	0
IN4	1	1	0	0
IN5	0	0	1	0
IN6	1	0	1	0
IN7	0	1	1	0
IN8	1	1	1	0
IN9	0	0	0	1
IN10	1	0	0	1
mute	1	1	1	1

Cf 1) When this volume mute slot is selected to ON,

all master volume slot are set to the condition of $-\infty$.

It is set to the same condition by using external mute terminal(24pin).

<The relation between volume mute and external mute> _ _

VOLUME MUTE(DD3)	EXTERNAL MUTE(24pin)	INTERNAL CONDITION
0	0	Mute OFF
0	1	Mute ON
1	0	Mute ON
1	1	Mute ON

(6) Discrete 5.1ch Input SW Setting Code

D44	D54	Lch	Rch	SLch	SRch	Cch	SWch	5.1ch Input Switch Setting
0	0	5.1ch Analog Setting						SW1b,SW2b,SW3a,SW4a,SW5a,SW6a ON
0	1	5.1ch Digital Setting						SW1c,SW2c,SW3b,SW4b,SW5b,SW6b ON
1	0	Bypass	Bypass	5.1ch Analog Setting			SW1a,SW2a,SW3a,SW4a,SW5a,SW6a ON	
1	1	Bypass	Bypass	5.1ch Digital Setting			SW1a,SW2a,SW3b,SW4b,SW5b,SW6b ON	

PRELIMINARY
 Notice: This is not a final specification.
 some parametric limits are subject to change.

MITSUBISHI SOUND PROCESSORS
M61511FP
 AUDIO SIGNAL PROCESSOR

(7) Master Volume Setting Code

X means data slot, Lch and Rch are "0", SLch and SRch are "1", Cch and SWch are "2".
 Please refer format page5 in detail.
 # No guarantee except for these code.

ATT Value	D0X D7X	D1X D8X	D2X D9X	D3X DAX	D4X DBX	D5X DCX	D6X DDX	ATT Value	D0X D7X	D1X D8X	D2X D9X	D3X DAX	D4X DBX	D5X DCX	D6X DDX
0dB	0	0	0	0	0	0	0	-49dB	1	0	0	0	1	1	0
-1dB	1	0	0	0	0	0	0	-50dB	0	1	0	0	1	1	0
-2dB	0	1	0	0	0	0	0	-51dB	1	1	0	0	1	1	0
-3dB	1	1	0	0	0	0	0	-52dB	0	0	1	0	1	1	0
-4dB	0	0	1	0	0	0	0	-53dB	1	0	1	0	1	1	0
-5dB	1	0	1	0	0	0	0	-54dB	0	1	1	0	1	1	0
-6dB	0	1	1	0	0	0	0	-55dB	1	1	1	0	1	1	0
-7dB	1	1	1	0	0	0	0	-56dB	0	0	0	1	1	1	0
-8dB	0	0	0	1	0	0	0	-57dB	1	0	0	1	1	1	0
-9dB	1	0	0	1	0	0	0	-58dB	0	1	0	1	1	1	0
-10dB	0	1	0	1	0	0	0	-59dB	1	1	0	1	1	1	0
-11dB	1	1	0	1	0	0	0	-60dB	0	0	1	1	1	1	0
-12dB	0	0	1	1	0	0	0	-61dB	1	0	1	1	1	1	0
-13dB	1	0	1	1	0	0	0	-62dB	0	1	1	1	1	1	0
-14dB	0	1	1	1	0	0	0	-63dB	1	1	1	1	1	1	0
-15dB	1	1	1	1	0	0	0	-64dB	0	0	0	0	0	0	1
-16dB	0	0	0	0	1	0	0	-65dB	1	0	0	0	0	0	1
-17dB	1	0	0	0	1	0	0	-66dB	0	1	0	0	0	0	1
-18dB	0	1	0	0	1	0	0	-67dB	1	1	0	0	0	0	1
-19dB	1	1	0	0	1	0	0	-68dB	0	0	1	0	0	0	1
-20dB	0	0	1	0	1	0	0	-69dB	1	0	1	0	0	0	1
-21dB	1	0	1	0	1	0	0	-70dB	0	1	1	0	0	0	1
-22dB	0	1	1	0	1	0	0	-71dB	1	1	1	0	0	0	1
-23dB	1	1	1	0	1	0	0	-72dB	0	0	0	1	0	0	1
-24dB	0	0	0	1	1	0	0	-73dB	1	0	0	1	0	0	1
-25dB	1	0	0	1	1	0	0	-74dB	0	1	0	1	0	0	1
-26dB	0	1	0	1	1	0	0	-75dB	1	1	0	1	0	0	1
-27dB	1	1	0	1	1	0	0	-76dB	0	0	1	1	0	0	1
-28dB	0	0	1	1	1	0	0	-77dB	1	0	1	1	0	0	1
-29dB	1	0	1	1	1	0	0	-78dB	0	1	1	1	0	0	1
-30dB	0	1	1	1	1	0	0	-79dB	1	1	1	1	0	0	1
-31dB	1	1	1	1	1	0	0	-80dB	0	0	0	0	1	0	1
-32dB	0	0	0	0	0	1	0	-81dB	1	0	0	0	1	0	1
-33dB	1	0	0	0	0	1	0	-82dB	0	1	0	0	1	0	1
-34dB	0	1	0	0	0	1	0	-83dB	1	1	0	0	1	0	1
-35dB	1	1	0	0	0	1	0	-84dB	0	0	1	0	1	0	1
-36dB	0	0	1	0	0	1	0	-85dB	1	0	1	0	1	0	1
-37dB	1	0	1	0	0	1	0	-86dB	0	1	1	0	1	0	1
-38dB	0	1	1	0	0	1	0	-87dB	1	1	1	0	1	0	1
-39dB	1	1	1	0	0	1	0	-88dB	0	0	0	1	1	0	1
-40dB	0	0	0	1	0	1	0	-89dB	1	0	0	1	1	0	1
-41dB	1	0	0	1	0	1	0	-90dB	0	1	0	1	1	0	1
-42dB	0	1	0	1	0	1	0	-91dB	1	1	0	1	1	0	1
-43dB	1	1	0	1	0	1	0	-92dB	0	0	1	1	1	0	1
-44dB	0	0	1	1	0	1	0	-93dB	1	0	1	1	1	0	1
-45dB	1	0	1	1	0	1	0	-94dB	0	1	1	1	1	0	1
-46dB	0	1	1	1	0	1	0	-95dB	1	1	1	1	1	0	1
-47dB	1	1	1	1	0	1	0	-∞	1	1	1	1	1	1	1
-48dB	0	0	0	0	1	0	0								

PRELIMINARY
 Notice: This is not a final specification.
 Some parametric limits are subject to change.

MITSUBISHI SOUND PROCESSORS
M61511FP
 AUDIO SIGNAL PROCESSOR

ELECTRIC CHARACTERISTICS

(Unless otherwise noted, $T_a=25^\circ\text{C}$, $AVCC=7.0\text{V}$, $AVSS=-7.0\text{V}$, $DVDD=5.0\text{V}$, $f=1\text{kHz}$,
 Input Gain Control=0dB, Output Gain Control=0dB)

(1) SUPPLY VOLTAGE CHARACTERISTICS

Item	Symbol	Condition	Specification			Unit
			Min	Typ	Max	
Analog plus supply current	Alcc	AVCC=7.0V, AVSS=-7.0V measurement terminal=17, 18pin no input signal	-	30	50	mA
Analog minus supply current	Alss	AVCC=7.0V, AVSS=-7.0V measurement terminal=25, 26pin no input signal	-50	-30	-	mA
Digital supply current	Dlidd1	DVDD=5V measurement terminal=23pin no input signal	-	0.3	1.2	mA
	Dlidd2	DVDD=3.3V measurement terminal=23pin no input signal	-	0.2	0.8	mA

(2) I/O CHARACTERISTICS

Item	Symbol	Condition	Specification			Unit	
			Min	Typ	Max		
Input resistance	Rin	1~3, 62~64, 68~71pin 6~8pin, 57~59pin, 74~77pin 11~16pin, A27~32pin	25	47	100	k Ω	
Maximum input voltage	VIM	57~59pin Input, 9pin Output RL=10k Ω , THD=1%, Selector Output ATT =-6dB	3.6	4.0	-	Vrms	
Maximum output voltage	VOM	11~16pin Input 35, 39, 43, 47, 51, 55pin Output RL=10k Ω , THD=1%, Output Gain =10dB	3.6	4.0	-	Vrms	
Output voltage	Vodc	no input signal	-0.4	0.0	0.4	V	
	Vrecdc	no input signal	-0.4	0.0	0.4	V	
Through gain	Gv	Vi=1Vrms, FLAT, gain of (62-51pin) and (59-55pin)	-2.0	0.0	2.0	dB	
Maximum attenuate value	ATT	Vi=1Vrms, 55, 51pin JIS-A, VOL=- ∞	-	-100	-95	dB	
Output noise voltage	Vono	JIS-A, Rg=10k Ω , no input signal	Vol=0dB	-	20.0	40.0	μVrms
		Output Gain = 10dB	Vol=- ∞	-	9.0	15.0	μVrms
	Vrecno	JIS-A, Rg=10k Ω , no input signal	-	5.0	10.0	μVrms	
Total harmonic distortion	THD1	BW:400~30kHz, Vo=0.5Vrms, RL=10k Ω	-	0.01	0.05	%	
	THD2	BW:400~30kHz, Vo=2.0Vrms, RL=10k Ω	-	0.05	0.5	%	
	THDrec1	BW:400~30kHz, Vo=0.5Vrms, RL=30k Ω	-	0.01	0.05	%	
	THDrec2	BW:400~30kHz, Vo=2.0Vrms, RL=30k Ω	-	0.1	0.5	%	
Channel crosstalk	CT	Vo=0.5Vrms, RL=10k Ω , JIS-A, Rg=0 Ω	-	-80	-60	dB	
	CTrec	Vo=0.5Vrms, RL=30k Ω , JIS-A, Rg=0 Ω	-	-80	-60	dB	
Channel balance	CBAL	Vo=0.5Vrms, RL=10k Ω , JIS-A	-0.5	0	0.5	dB	
	CBALrec	Vo=0.5Vrms, RL=30k Ω , JIS-A	-0.5	0	0.5	dB	

PRELIMINARY
 Notice: This is not a final specification.
 Some parametric limits are subject to change.

MITSUBISHI SOUND PROCESSORS
M61511FP
 AUDIO SIGNAL PROCESSOR

APPLICATION EXAMPL

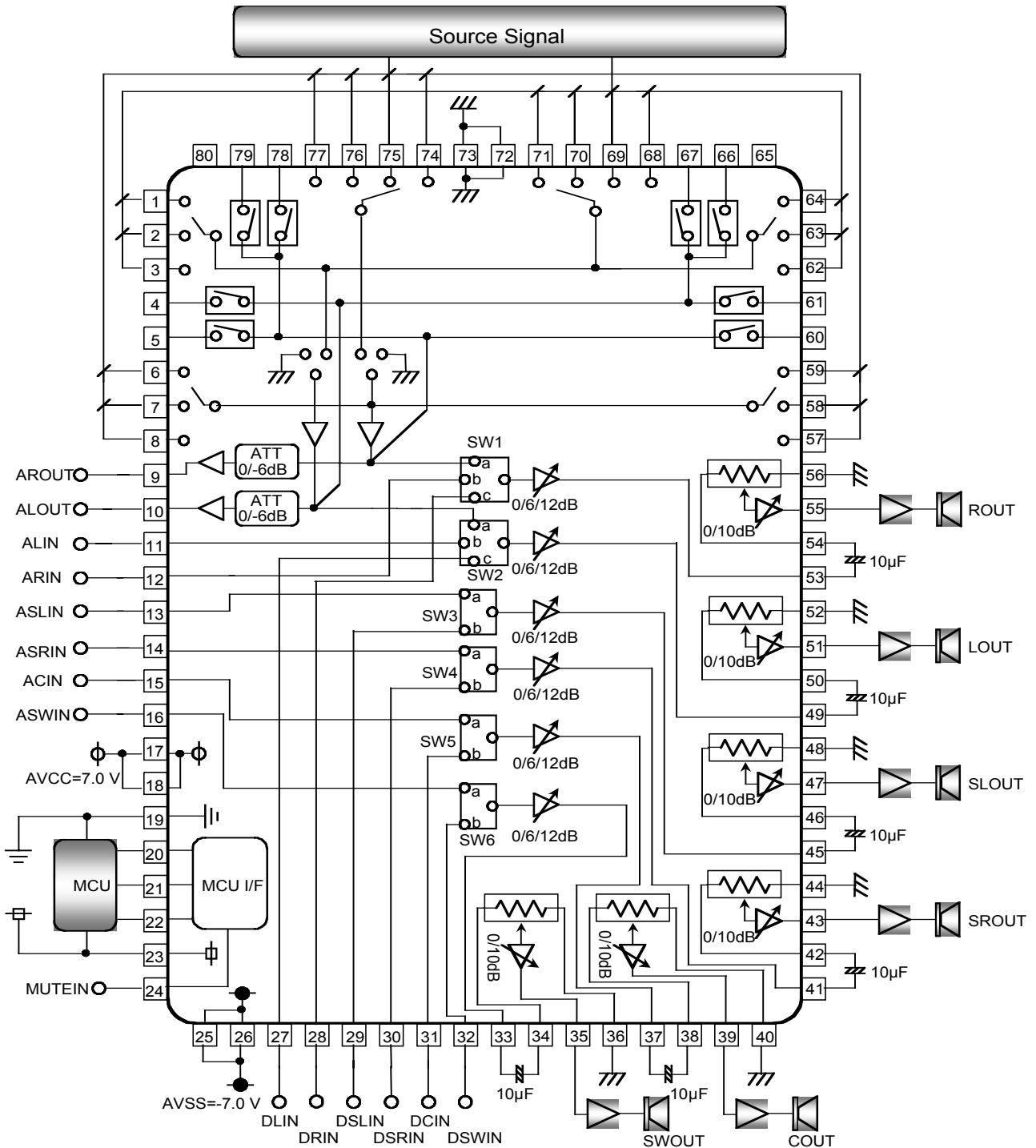

PRELIMINARY
 Notice: This is not a final specification.
 some parametric limits are subject to change.

MITSUBISHI SOUND PROCESSORS
M61511FP
 AUDIO SIGNAL PROCESSOR

PIN DESCRIPTION

	Pin No.	Symbol	function Description	
Selector	62,63,64 68,69,70,71 1,2,3	LIN1~10	Lch Input Selector Input Terminal	
	59,58,57 77,76,75,74 8,7,6	RIN1~10	Rch Input Selector Input Terminal	
	61,66,67,4	LREC1~4	Lch REC Output Terminal	
	60,79,78,5	RREC1~4	Rch REC Output Terminal	
	10	ALOUT	Lch Analog Output Terminal	
	9	AROUT	Rch Analog Output Terminal	
	72,73	AGND	Selector Block Gnd Terminal	
Volume	11,12 13,14 15,16	ALIN,ARIN ASLIN,ASRIN ACIN,ASWIN	5.1ch Analog Input Terminal	
	27,28 29,30 31,32	DLIN,DRIN DSLIN,DSRIN DCIN,DSWIN	5.1ch Digital Input Terminal	
	49 53 45 42 37 33	LSELOUT RSELOUT SLSELOUT SRSELOUT CSELOUT SWSELOUT	Input Gain Control Output Terminal	
	50 54 46 42 37 34	LVOLIN RVOLIN SLVOLIN SRVOLIN CVOLIN SWVOLIN	Volume Input Terminal	
	51,55 47,43 39,35	LOUT,ROUT SLOUT,SROUT COUT,SWOUT	Output Gain Control Output Terminal	
	52,56 48,44 40,36	LGND,RGND SLGND,SRGND CGND,SWGND	Volume Block Gnd Terminal	
	17,18	AVCC	Analog Plus Supply Voltage Terminal	
	25,26	AVSS	Analog Minus Supply Voltage Terminal	
	Logic	20,21,22	DATA,CLK,LATCH	MCU I/F Terminal
		24	MUTEIN	External Mute Terminal
		23	DVDD	Digital Supply Voltage Terminal
		19	DGND	Digital Gnd Terminal
	65,80	NC	No Connect Terminal	