

**PRELIMINARY**  
 Notice: This is not a final specification.  
 some parametric limits are subject to change.

MITSUBISHI SOUND PROCESSORS  
**M61512FP**  
 5.1ch Electronic Volume

**6ch Electric Volume with 6 Input Selector**

**APPLICATION**

AV amp, Mini Compo etc.

**FEATURE**

- 6 Input Selector (6ch+MUTE)
- Input Gain Control (0/3/6/9dB)
- INPUT ATT (0/-5dB)
- 6ch Dependent Electronic Volume  
 (6ch 0~-87dB, - ) FL,FR,C,SL,SR,SWch
- 2 Lines REC Output  
 (for one thing built in mute switch)
- Built in Bass Boost circuit (FL,FRch)
- 9V single power source

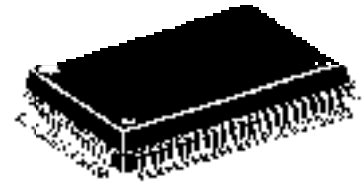

**OUTLINE 80P6N**  
 0.8mm pitch QFP  
 (20.0X14.0X2.8mm)

**RECOMMENDED OPERATING CONDITION**

Analog Supply Voltage Range AVcc=8.0V~10.0V  
 Digital Supply Voltage Range DVdd=3.0V~5.5V

**SYSTEM BLOCK DIAGRAM**

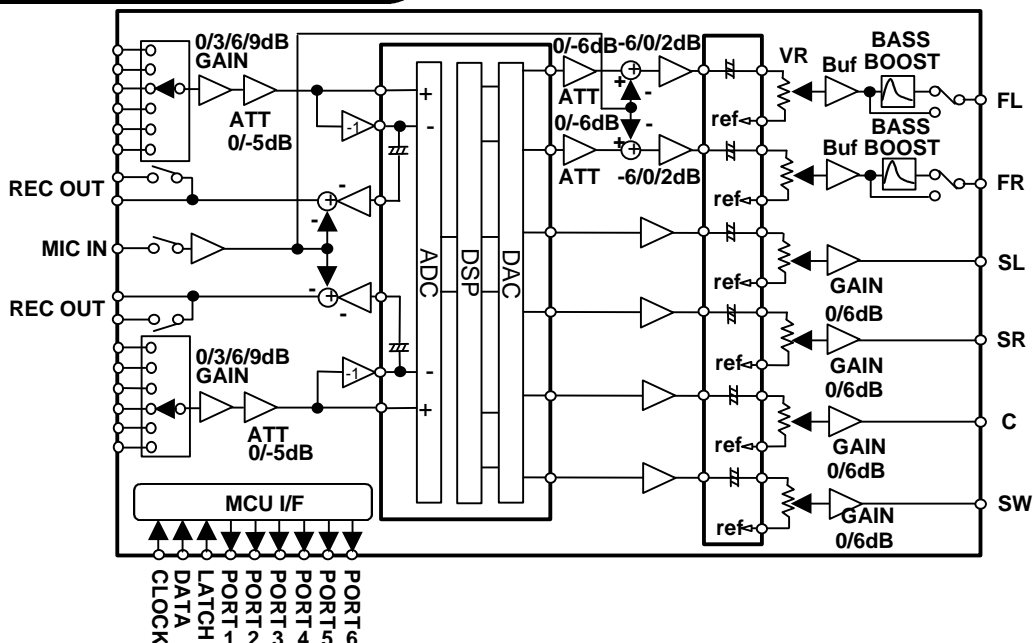

**PRELIMINARY**  
 Notice: This is not a final specification.  
 some parametric limits are subject to change.

MITSUBISHI SOUND PROCESSORS  
**M61512FP**  
 5.1ch Electronic Volume

**BLOCK DIAGRAM AND PIN ASSIN**

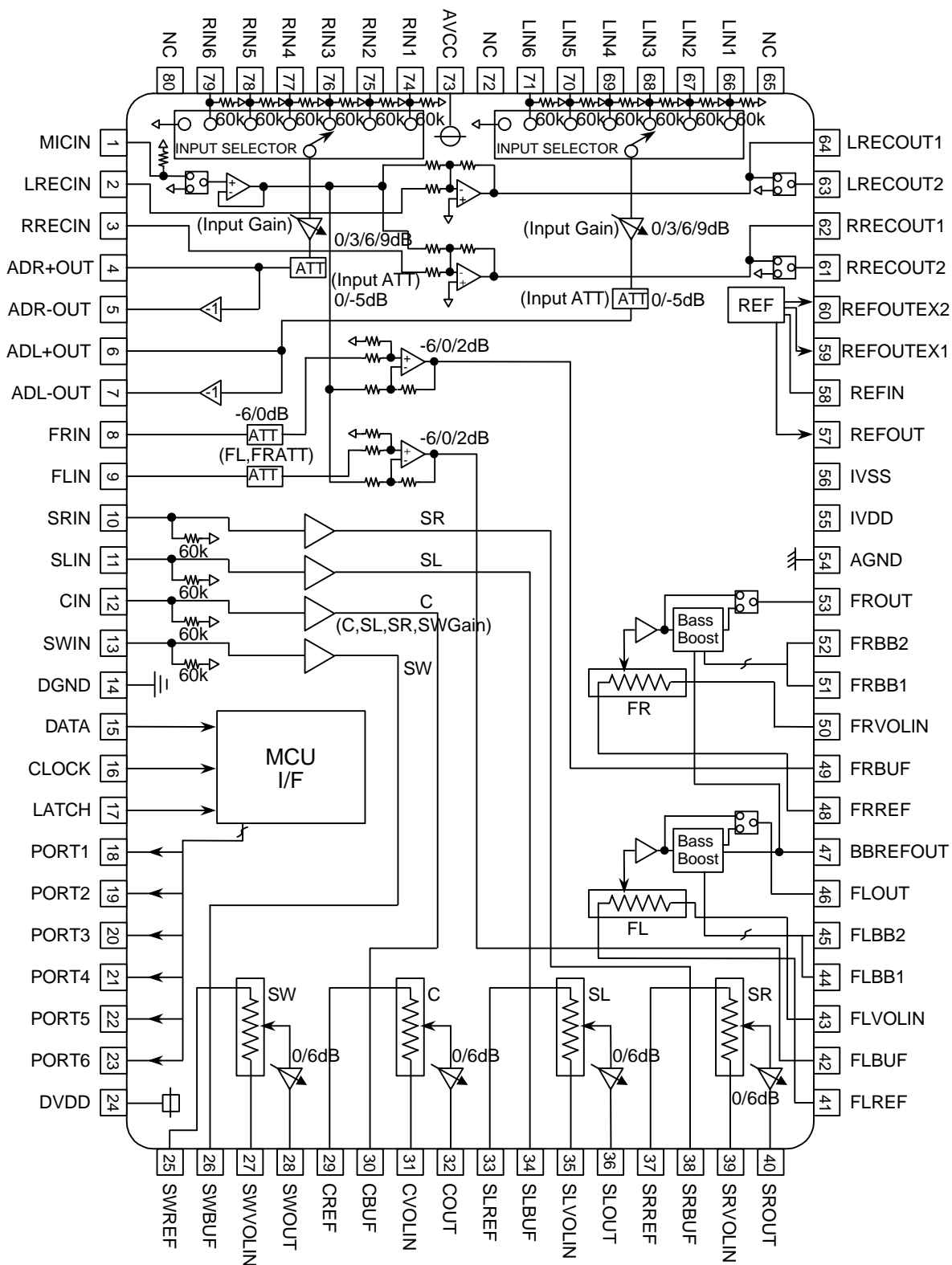

**PRELIMINARY**  
 Notice: This is not a final specification.  
 some parametric limits are subject to change.

MITSUBISHI SOUND PROCESSORS  
**M61512FP**  
 5.1ch Electronic Volume

**ELECTRIC CHARACTERISTICS**

(Unless otherwise noted, Ta=25°C, Vcc=9.0V, Vdd=5.0V, f=1KHz, BassBoost:off)

(1) ABSOLUTE MAXIMUM RATINGS

Symbol	Parameter	Condition	Limits	Unit
Vcc	Supply voltage		10.5	V
VDD			6.5	V
Pd	Power dissipation		1.4	W
Topr	Operating temperature		-20 to +75	°C
Tstg	Storage temperature		-40 to +125	°C

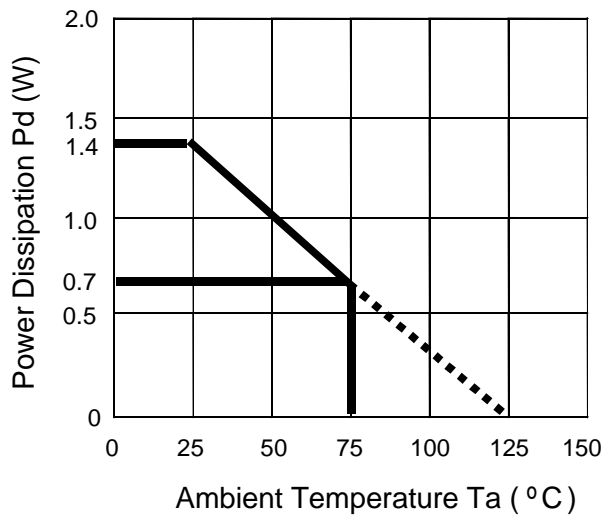

(2) RECOMMENDED OPERATING CONDITION

Symbol	Item	Condition	Range			Unit
			Min	typ	Max	
Vcc	Supply voltage		8.0	9.0	10.0	V
VDD			3.0	5.0	5.5	V
VIL	Logic "L" Level Input Voltage	Pin15,16,17	0.0	-	0.8	V
VIH	Logic "H" Level Input Voltage	Pin15,16,17	2.0	-	VDD	V

(3) ELECTRIC CHARACTERISTICS

Symbol	Item	Condition	Range			Unit
			Min	typ	Max	
Analog supply current	AICC	Vcc=9.0V Measurement terminal=pin73 No input signal	-	25	40	mA
Digital supply current	Didd	Vcc=5.0V Measurement terminal=pin23 No input signal	-	0.8	1.5	mA

**PRELIMINARY**  
 Notice: This is not a final specification.  
 some parametric limits are subject to change.

MITSUBISHI SOUND PROCESSORS  
**M61512FP**  
 5.1ch Electronic Volume

(Unless otherwise noted, Ta=25°C, Vcc=9.0V, Vdd=5.0V, f=1KHz, BassBoost:off)

(4) I/O CHARACTERISTICS

Symbol	Item	Condition	Range			Unit	
			Min	typ	Max		
Input resistance	Rin	66pin, 74pin	30	60	90	K	
Maximum input voltage	Vin	66pin, 74pin	–	2.2	2.4	Vrms	
FL, FROUT maximum Output Voltage	Vom	Pin8,9 input, pin46,53 output Gain=2dB RL=10K, THD=1%	–	#1.4	#1.5	Vrms	
RECOUT maximum Output Voltage	Vomrec	Pin2,3 input, pin62,64 output RL=10K, THD=1%	–	2.2	2.4	Vrms	
C, SL, SR, SWVOLOUT maximum output voltage	Vomvol	Pin10,11 input pin46,53 output Gain=6dB RL=10K, THD=1%	–	2.2	2.4	Vrms	
FL, FROUT offset voltage	Vodc	46pin, 53pin no input signal	4.0	4.5	5.0	V	
RECOUT offset voltage	Vrecdc	62pin, 64pin no input signal	4.0	4.5	5.0	V	
C, SL, SR, SWVOLOUT offset voltage	Vvoldc	40pin, 36pin no input signal	4.0	4.5	5.0	V	
Through gain	Gv	Vin=1Vrms, FLAT ATT=-6dB, Gain=2dB Gain of(66,74pin)-(46,53pin)	–	-4.0	–	dB	
Maximum attenuate value	ATT	Vo=1Vrms, 40, 36pin JIS-A	-87	-92	–	dB	
ADOUT Output noise voltage	Vadno	JIS-A, no input signal Rg=10K 5,7pin, ATT=0dB, Gain=0dB	–	4.0	12.0	μVrms	
RECOUT Output noise voltage	Vrecno	JIS-A, no input signal Rg=10K, 61, 63pin	–	6.0	15.0	μVrms	
FL, FROUT Output noise voltage	Vono1	JIS-A No input signal Rg=10K	62, 64pin	–	7.0	15.0	μVrms
C, SL, SR, SWVOLOUT Output noise voltage	Vvolno1	ATT=0dB, Gain=0dB B, Vol=0dB					
FL, FROUT Output noise voltage	Vono2	JIS-A No input signal Rg=10K	46, 53pin	–	5.0	10.0	μVrms
C, SL, SR, SWVOLOUT Output noise voltage	Vvolno2	ATT=0dB, Gain=0dB B, Vol=- dB					
FL, FROUT Total harmonic distortion	THD	46pin, 53pin BW=400~30KHz Vo=300mVrms, RL=10K	–	0.01	0.05	%	
RECOUT Total harmonic distortion	THDrec	62pin, 64pin BW=400~30KHz Vo=300mVrms, RL=30K	–	0.01	0.05	%	
C, SL, SR, SWVOLOUT Total harmonic distortion	THDvol	40pin, 36pin BW=400~30KHz Vo=300mVrms, RL=51K	–	0.01	0.05	%	
Channel crosstalk	CT	Vo=0.5Vrms, RL=10K JIS-A 46pin-53pin, Rg=10K	–	-70	-55	dB	
	CTrec	Vo=0.5Vrms, RL=30K JIS-A 62pin-64pin, Rg=10K	–	-70	-55	dB	

#When bass boost "ON", Output level is as high as other output level at Bass Boost resonance frequency.

**PRELIMINARY**  
 Notice: This is not a final specification.  
 some parametric limits are subject to change.

MITSUBISHI SOUND PROCESSORS  
**M61512FP**  
 5.1ch Electronic Volume

**DATA INPUT FORMAT**

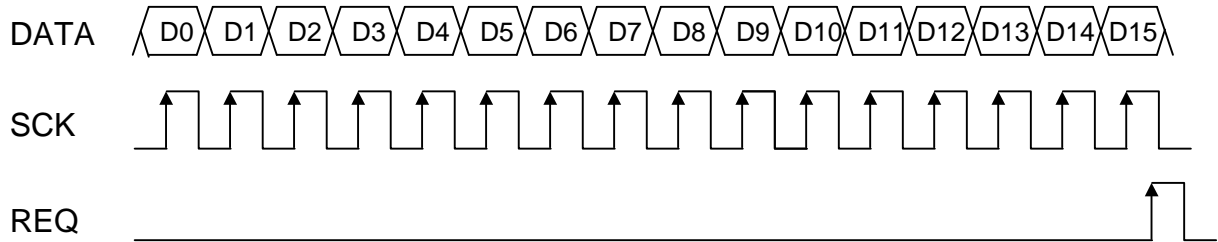

(Please set all data of nine input formats when every power supply is applied.)

	D0	D1	D2	D3	D4	D5	D6	D7	D8	D9	D10	D11	D12	D13	D14	D15	
A	0	0	0	0	(1) Input Selector			(2) Input Gain		(3) InputATT	(4) FL,FR,ATT	(5) FL,FRGain		(6) SL,SR,C SWGain		Chip Address  1 1	
B	0	0	0	1	(16) ALL MUTE	(7) MIC MUTE	(8) REC2 MUTE	(9) Bass Boost	(10) PORT1 CONT	(11) PORT2 CONT	(12) PORT3 CONT	(13) PORT4 CONT	(14) PORT5 CONT	(15) PORT6 CONT			
C	1	0	0	0				(17) Lch Volume									
D	1	0	0	1				(17) Rch Volume									
E	1	0	1	0				(17) Cch Volume									
F	1	0	1	1				(17) SLch Volume									
G	1	1	0	0				(17) SRch Volume									
H	1	1	0	1				(17) SWch Volume									

<Initial condition when power supply is applied>

- Input selector: MUTE
- Input Gain: 0dB
- Input ATT: 0dB
- FL,FR ATT: -6dB
- FL,FR Gain: 2dB
- SL,SR,C,SW Gain: 0dB
- MIC MUTE: MUTE
- REC2 MUTE: THRU
- Bass Boost: NO BOOST
- OUTPUTPORT1: PORT1OFF
- OUTPUTPORT2: PORT2OFF
- OUTPUTPORT3: PORT3OFF
- OUTPUTPORT4: PORT4OFF
- OUTPUTPORT5: PORT5OFF
- OUTPUTPORT6: PORT6OFF
- ALL MUTE: NO MUTE
- LchVOL: - dB
- RchVOL: - dB
- CchVOL: - dB
- SLchVOL: - dB
- SRchVOL: - dB
- SWchVOL: - dB

#No guarantee except for these code.

**PRELIMINARY**  
 Notice: This is not a final specification.  
 some parametric limits are subject to change.

MITSUBISHI SOUND PROCESSORS  
**M61512FP**  
 5.1ch Electronic Volume

(1) Input selector setting code

INPUT SEL.	D4A	D5A	D6A
1	0	0	0
2	0	0	1
3	0	1	0
4	0	1	1
5	1	0	0
6	1	0	1
MUTE	1	1	1

(2) Input gain setting code

INPUT Gain	D7A	D8A
±0dB	0	0
3dB	0	1
6dB	1	0
9dB	1	1

(3) Input ATT setting code(#)

INPUT ATT	D9A
±0dB	0
-5dB	1

(#) There is a restriction combination of input ATT and input gain. (refer to below table)

INPUT ATT	Input Gain possible to set
±0dB	0/3/6/9dB
-5dB	0/6dB

(4) FL,FR ATT setting code

FL,FR ATT	D10A
0dB	0
-6dB	1

(5) FL,FR Gain setting code

Gain AMP	D11A	D12A
-6dB	0	0
±0dB	0	1
2dB	1	0

(6) SL,SR,C,SW Gain setting code

Gain AMP	D13A
0dB	0
6dB	1

(7) Microphone mute setting code

MIC	D5B
THRU	0
MUTE	1

(8) REC2 MUTE setting code

REC2	D6B
THRU	0
MUTE	1

(9) Bass Boost setting code

Bass Boost	D7B
No Boost	0
Boost ON	1

(10) OUTPUTPORT1 setting code

PORT1	D8B
PORT1OFF	0
PORT1ON	1

(11) OUTPUTPORT2 setting code

PORT2	D9B
PORT2OFF	0
PORT2ON	1

(12) OUTPUTPORT3 setting code

PORT3	D10B
PORT3OFF	0
PORT3ON	1

(13) OUTPUTPORT4 setting code

PORT4	D11B
PORT4OFF	0
PORT4ON	1

(14) OUTPUTPORT5 setting code

PORT5	D12B
PORT5OFF	0
PORT5ON	1

(15) OUTPUTPORT6 setting code

PORT6	D13B
PORT6OFF	0
PORT6ON	1

(16) ALL MUTE setting code

DPL	D4B
NO MUTE	0
ALL MUTE	1

ALL MUTE setting:

Volume=-

Input SELECTOR=MUTE

**PRELIMINARY**  
 Notice: This is not a final specification.  
 some parametric limits are subject to change.

MITSUBISHI SOUND PROCESSORS  
**M61512FP**  
 5.1ch Electronic Volume

(17) Volume setting code  
 (FLch,FRch,Cch,SLch,SRch,SWch)

ATT	D7C-H	D8C-H	D9C-H	D10C-H	D11C-H	D12C-H	D13C-H
±0dB	0	0	0	0	0	0	0
-1.0dB	1	0	0	0	0	0	0
-2.0dB	0	1	0	0	0	0	0
-3.0dB	1	1	0	0	0	0	0
-4.0dB	0	0	1	0	0	0	0
-5.0dB	1	0	1	0	0	0	0
-6.0dB	0	1	1	0	0	0	0
-7.0dB	1	1	1	0	0	0	0
-8.0dB	0	0	0	1	0	0	0
-9.0dB	1	0	0	1	0	0	0
-10.0dB	0	1	0	1	0	0	0
-11.0dB	1	1	0	1	0	0	0
-12.0dB	0	0	1	1	0	0	0
-13.0dB	1	0	1	1	0	0	0
-14.0dB	0	1	1	1	0	0	0
-15.0dB	1	1	1	1	0	0	0
-16.0dB	0	0	0	0	1	0	0
-17.0dB	1	0	0	0	1	0	0
-18.0dB	0	1	0	0	1	0	0
-19.0dB	1	1	0	0	1	0	0
-20.0dB	0	0	1	0	1	0	0
-21.0dB	1	0	1	0	1	0	0
-22.0dB	0	1	1	0	1	0	0
-23.0dB	1	1	1	0	1	0	0
-24.0dB	0	0	0	1	1	0	0
-25.0dB	1	0	0	1	1	0	0
-26.0dB	0	1	0	1	1	0	0
-27.0dB	1	1	0	1	1	0	0
-28.0dB	0	0	1	1	1	0	0
-29.0dB	1	0	1	1	1	0	0
-30.0dB	0	1	1	1	1	0	0
-31.0dB	1	1	1	1	1	0	0
-32.0dB	0	0	0	0	0	1	0
-33.0dB	1	0	0	0	0	1	0
-34.0dB	0	1	0	0	0	1	0
-35.0dB	1	1	0	0	0	1	0
-36.0dB	0	0	1	0	0	1	0
-37.0dB	1	0	1	0	0	1	0
-38.0dB	0	1	1	0	0	1	0
-39.0dB	1	1	1	0	0	1	0
-40.0dB	0	0	0	1	0	1	0
-41.0dB	1	0	0	1	0	1	0
-42.0dB	0	1	0	1	0	1	0
-43.0dB	1	1	0	1	0	1	0
-44.0dB	0	0	1	1	0	1	0

ATT	D7C-H	D8C-H	D9C-H	D10C-H	D11C-H	D12C-H	D13C-H
-45.0dB	1	0	1	1	0	1	0
-46.0dB	0	1	1	1	0	1	0
-47.0dB	1	1	1	1	0	1	0
-48.0dB	0	0	0	0	1	1	0
-49.0dB	1	0	0	0	1	1	0
-50.0dB	0	1	0	0	1	1	0
-51.0dB	1	1	0	0	1	1	0
-52.0dB	0	0	1	0	1	1	0
-53.0dB	1	0	1	0	1	1	0
-54.0dB	0	1	1	0	1	1	0
-55.0dB	1	1	1	0	1	1	0
-56.0dB	0	0	0	1	1	1	0
-57.0dB	1	0	0	1	1	1	0
-58.0dB	0	1	0	1	1	1	0
-59.0dB	1	1	0	1	1	1	0
-60.0dB	0	0	1	1	1	1	0
-61.0dB	1	0	1	1	1	1	0
-62.0dB	0	1	1	1	1	1	0
-63.0dB	1	1	1	1	1	1	0
-64.0dB	0	0	0	0	0	0	1
-65.0dB	1	0	0	0	0	0	1
-66.0dB	0	1	0	0	0	0	1
-67.0dB	1	1	0	0	0	0	1
-68.0dB	0	0	1	0	0	0	1
-69.0dB	1	0	1	0	0	0	1
-70.0dB	0	1	1	0	0	0	1
-71.0dB	1	1	1	0	0	0	1
-72.0dB	0	0	0	1	0	0	1
-73.0dB	1	0	0	1	0	0	1
-74.0dB	0	1	0	1	0	0	1
-75.0dB	1	1	0	1	0	0	1
-76.0dB	0	0	1	1	0	0	1
-77.0dB	1	0	1	1	0	0	1
-78.0dB	0	1	1	1	0	0	1
-79.0dB	1	1	1	1	0	0	1
-80.0dB	0	0	0	0	1	0	1
-81.0dB	1	0	0	0	1	0	1
-82.0dB	0	1	0	0	1	0	1
-83.0dB	1	1	0	0	1	0	1
-84.0dB	0	0	1	0	1	0	1
-85.0dB	1	0	1	0	1	0	1
-86.0dB	0	1	1	0	1	0	1
-87.0dB	1	1	1	0	1	0	1
- dB	1	1	1	1	1	1	1

#No guarantee except for these code.

**PRELIMINARY**  
 Notice: This is not a final specification.  
 some parametric limits are subject to change.

MITSUBISHI SOUND PROCESSORS  
**M61512FP**  
 5.1ch Electronic Volume

**CLOCK, DATA, LATCH TIMING**

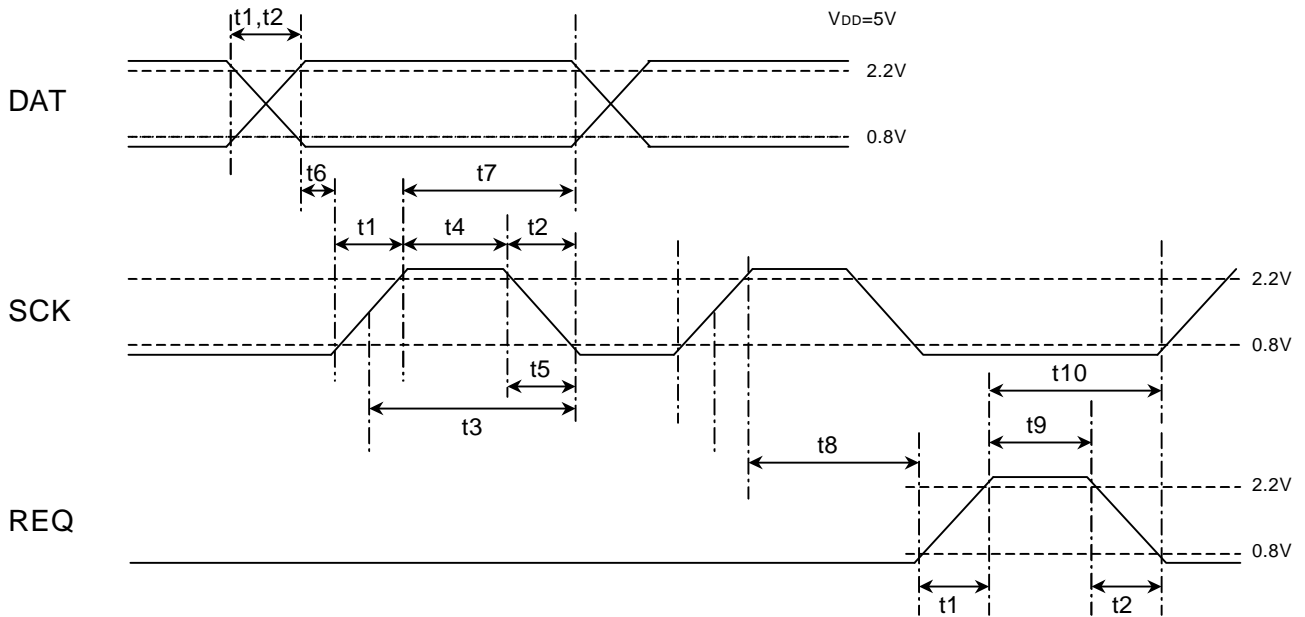

Symbol	ITEM	Min	Typ	Max	Unit
t1	Rise time of signal	-	-	0.3	μS
t2	Fall time of signal	-	-	0.3	μS
t3	SCK width of CLOCK	1	-	-	μS
t4	SCK Pulse width of "H"	0.4	-	-	μS
t5	SCK Pulse width of "L"	0.4	-	-	μS
t6	Set up time of DATA	0.4	-	-	μS
t7	Hold time of DATA	0.4	-	-	μS
t8	Set up time of REQ	0.8	-	-	μS
t9	Pulse width of REQ "H"	0.4	-	-	μS
t10	Set up time of SCK	0.4	-	-	μS



**PRELIMINARY**  
 Notice: This is not a final specification.  
 some parametric limits are subject to change.

MITSUBISHI SOUND PROCESSORS  
**M61512FP**  
 5.1ch Electronic Volume

**FUNCTION DESCRIPTION**

(1) INPUT SELECTOR, INPUT GAIN, INPUT ATT

This IC is build in selector with 2ch 6input+mute.  
 The Input selector is able to control source signal level at 0dB or -5dB by Input ATT Switch.  
 And , for low level source signal it is able to change the gain by Input Gain Switch.  
 But There is a restriction on combination of ATT level and Gain.(Refer to below table)

<Input ATT and Input Gain possible to combine>

INPUT ATT setting	INPUT Gain possible to set
0dB	0dB/3dB/6dB/9dB
-5dB	0dB/6dB

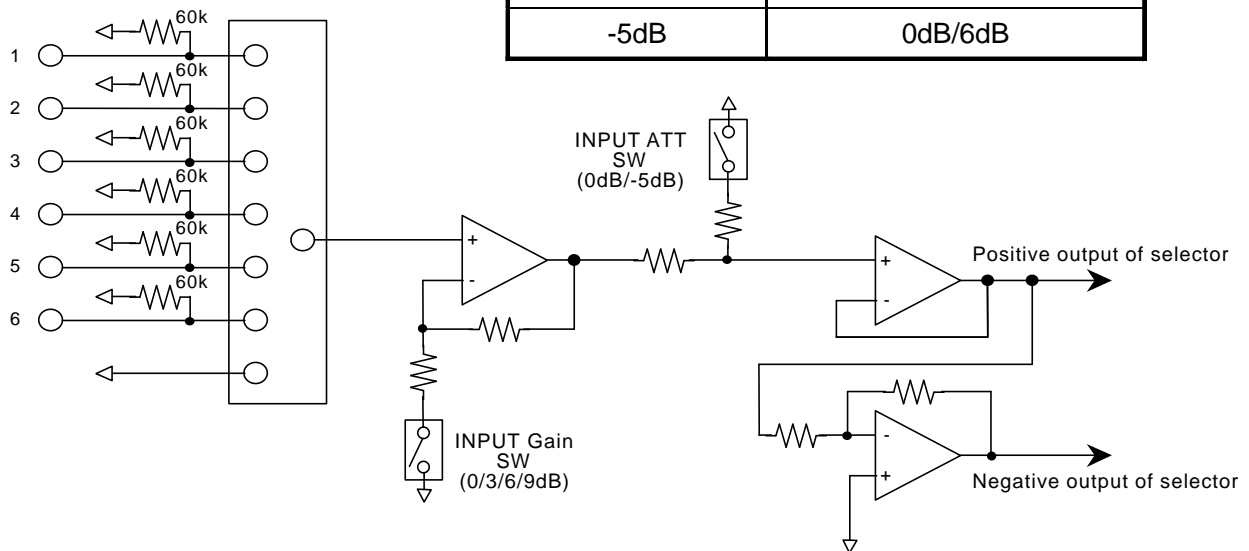

(2) REC Block

REC signal output after mixing to microphone signal.  
 The signal level mixed on is 0dB.  
 And REC OUT2 build in REC MUTE Switch.

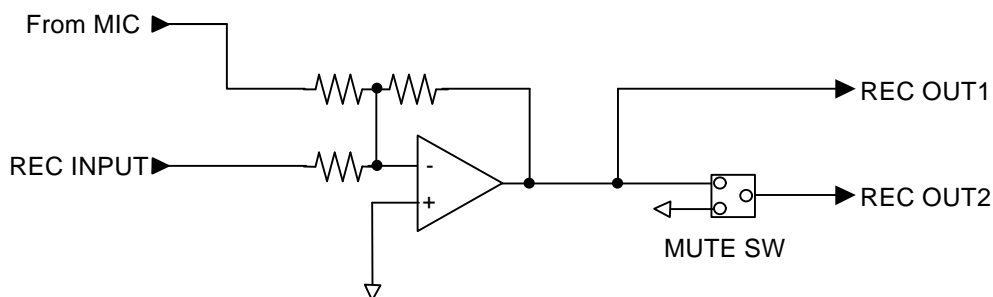

**PRELIMINARY**  
 Notice: This is not a final specification.  
 some parametric limits are subject to change.

MITSUBISHI SOUND PROCESSORS  
**M61512FP**  
 5.1ch Electronic Volume

(3) Microphone mixing

The microphone signal is mixed on L-ch or R-ch after pass through the buffer for decrease in crosstalk between L-ch and R-ch.

The signal level mixed on is 0dB.

And, This IC build in microphone mute switch for the purpose of improving noise characteristics.

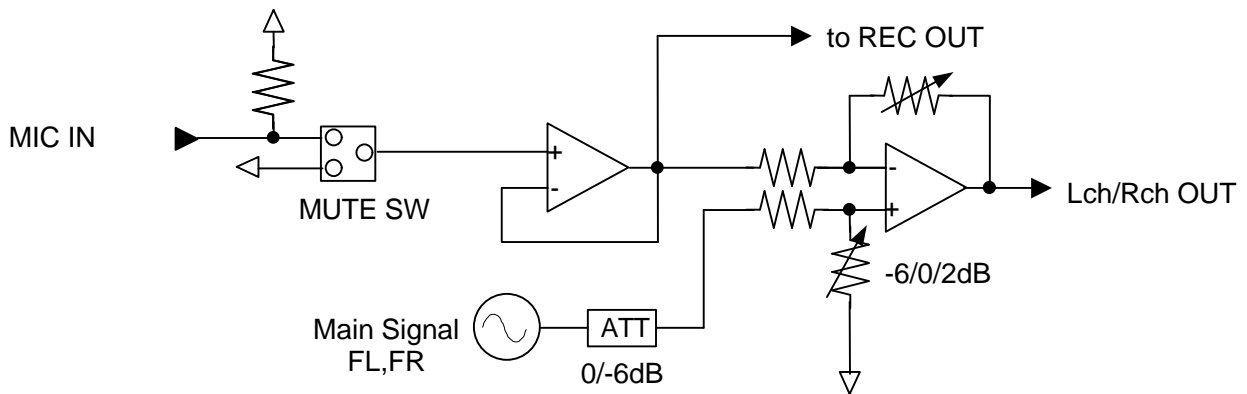

(4) Master Volume (FLch,FRch,Cch,SLch,SRch,SWch)

This IC build in 6ch independent electric volume with low distortion and low noise.

The volume is able to set steps by 1dB from 0dB to -87dB.

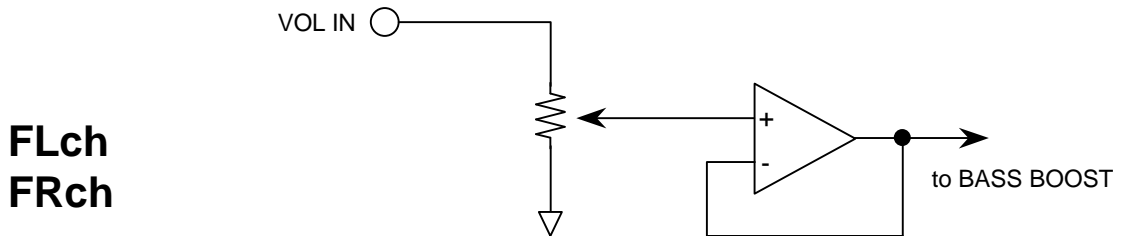

Volume: 0dB--87dB: 1dB Step, -

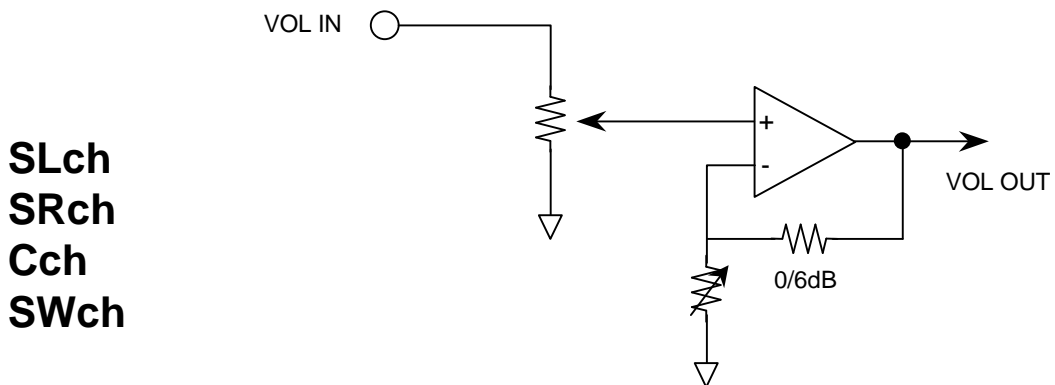

Volume: 0dB--87dB: 1dB Step, -

**PRELIMINARY**  
 Notice: This is not a final specification.  
 some parametric limits are subject to change.

MITSUBISHI SOUND PROCESSORS  
**M61512FP**  
 5.1ch Electronic Volume

(5) Equivalent circuit of Bass Boost

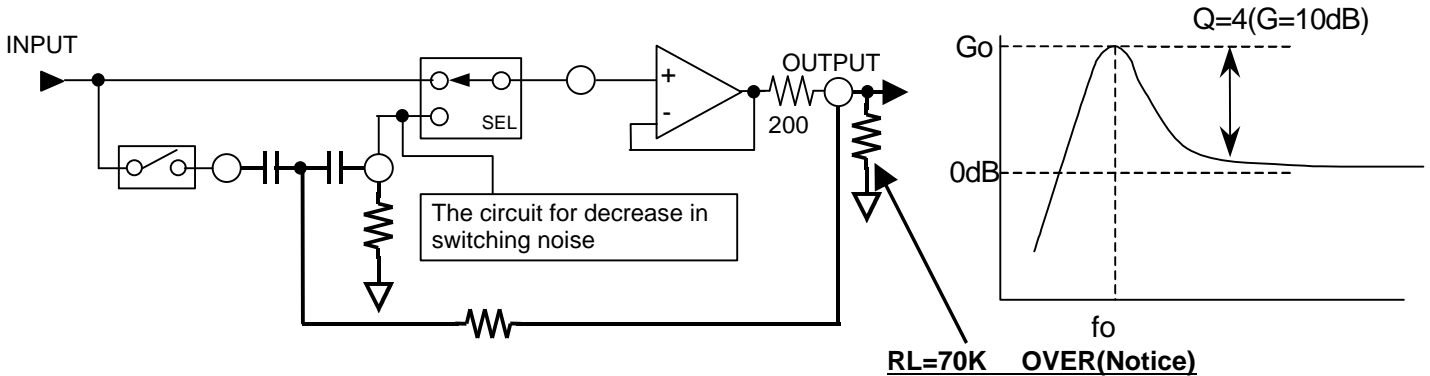

The circuit figure of positive feedback two order high pass filter circuit on bass boost part.

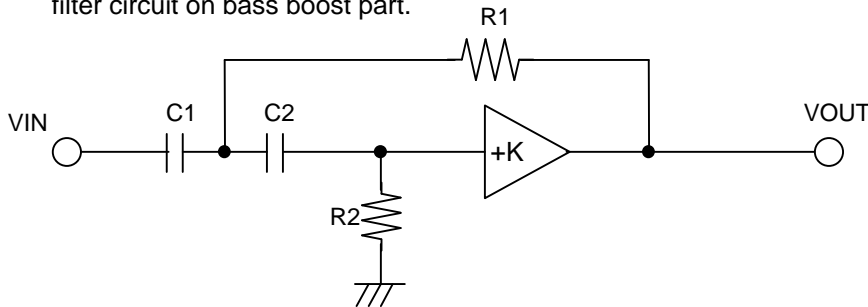

The amplitude characteristics of two order high pass filter circuit (Reference)

Q	G0
1	0~1dB
2	6dB
4	10dB
5	13dB
10	20dB

The transmission function is

$$\frac{V_{OUT}}{V_{IN}} = \frac{Ks^2}{s^2 + s \left[ \frac{1}{R2C1} + \frac{1}{R2C2} + (1-K) \frac{1}{R1C1} \right] + \frac{1}{R1R2C1C2}}$$

$$\omega^2 = \frac{1}{R1R2C1C2}$$

$$Q = \frac{1}{\sqrt{\frac{R1C1}{R2C2}} + \sqrt{\frac{R1C2}{R2C1}} + (1-K)\sqrt{\frac{R2C2}{R1C1}}}$$

The bass boost part is consist of two order high pass filter circuit.  
 We show an example how to calculate design value of bass boost part.

We let C1=C2 are Cf and K is +1.  
 Above equation is shown below.  
 Rf=1/(0Cf)     ••• (1)  
 R1=Rf/2Q     ••• (2)  
 R2=2QRf     ••• (3)

We let  $\omega$  is 2 x70Hz and Q is 10 in the case of the cutoff frequency is 70Hz and Q is 10.

We let C1=C2=Cf are 0.1μF.

From equation(1),(2),(3)

- Rf=23.5K
- R1=1.18K
- R2=470K

R1 become about 1.2K ,and R2 become about 470

**(Notice) Please set the load resistance on “fl-out(pin46)” or “fr-out(pin53)” at RL=70K over.**

**PRELIMINARY**  
 Notice: This is not a final specification.  
 some parametric limits are subject to change.

MITSUBISHI SOUND PROCESSORS  
**M61512FP**  
 5.1ch Electronic Volume

**Gain level diagram**

<INPUT SELECTOR>

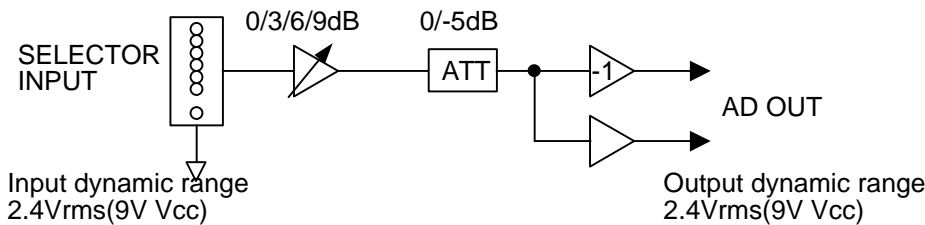

**TOTAL GAIN**

Total Gain (dB)	INPUT Gain(dB)	ATT (dB)
9	9	-
6	6	0
3	3	-
1	6	-5
0	0	0
-5	0	-5

<REC BLOCK>

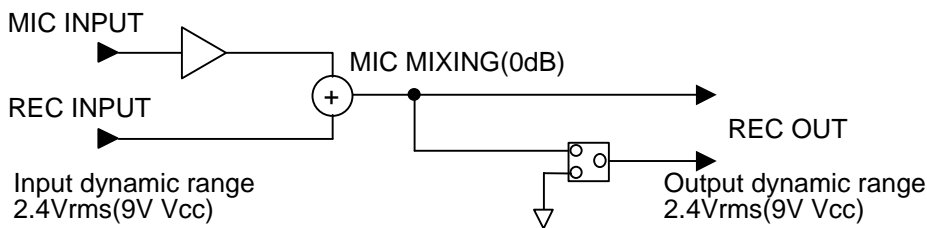

**TOTAL GAIN**  
**0dB(Mixed)**

<FL,FR BUF>

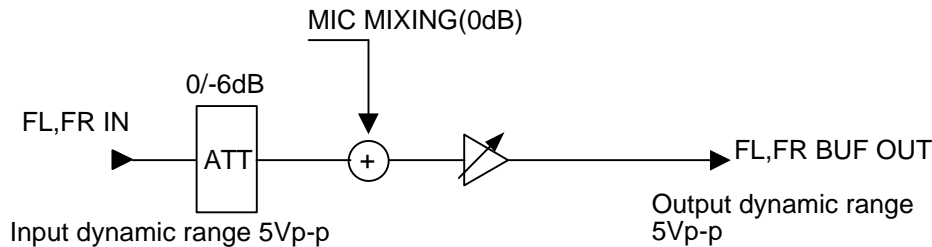

**TOTAL GAIN**

Total Gain (dB)	ATT (dB)	Gain (dB)
2	0	2
0	0	0
-4	-6	2
-6	0	-6
	-6	0
-12	-6	-6

<C~SW BUF>

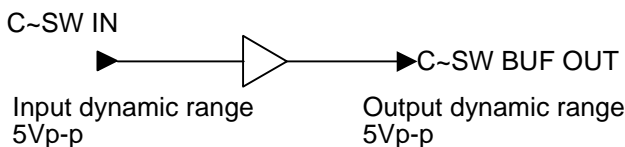

**TOTAL GAIN**  
**0dB**

<FL,FR Vol>

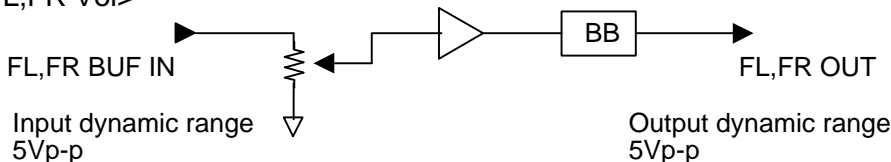

**TOTAL GAIN**  
**0dB(BBOff)**

<C~SW Vol>

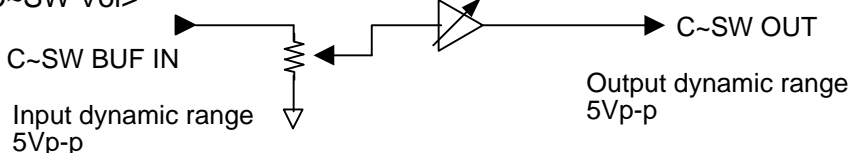

**TOTAL GAIN**  
**0dB or 6dB**

**PRELIMINARY**  
 Notice: This is not a final specification.  
 some parametric limits are subject to change.

MITSUBISHI SOUND PROCESSORS  
**M61512FP**  
 5.1ch Electronic Volume

**APPLICATION EXAMPLE**

