

**PRELIMINARY**  
 Notice ; This is not a final specification.  
 some parametric limits are subject to change.

MITSUBISHI SOUND PROCESSORS

# M62433FP

DIGITAL SOUND CONTROLLER

## SINGLE CHIP ANALOG SOUND PROCESSOR

### FEATURES

- Capable of controlling functions with serial data  
 6-input selector  
 5band tone control (0, ±3, ±6, ±10dB)  
 Bass boost (loudness type) [ON/OFF]  
 Surround (using external delay) [ON/OFF]  
 Voice cancel (stereo) [ON/OFF]  
 Multilingual record switching [L only/R only]  
 Electric volume 32steps ( 0dB ~ )  
 SW mode for control of DPL and other sound fields 3 lines for Rec output, 2 lines for port output
- Supporting digital delay
- Input/output of adapter supporting karaoke control

### PACKAGE

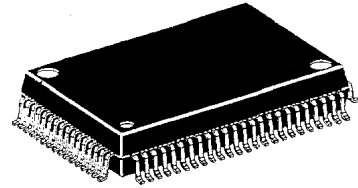

Outline 80P6N

Pitch : 0.8 mm  
 Size : 20.0 mm X 14.0mm  
 X 2.8mm

### APPLICATION

Home Audio equipment, Radio-Cassette tape recorder, TV

### RECOMMENDED OPERATING CONDITIONS

Supply voltage range •••• ±4.5 ~ ±7.3V  
 Rated supply voltage •••• ±7 V

### SYSTEM BLOCK DIAGRAM

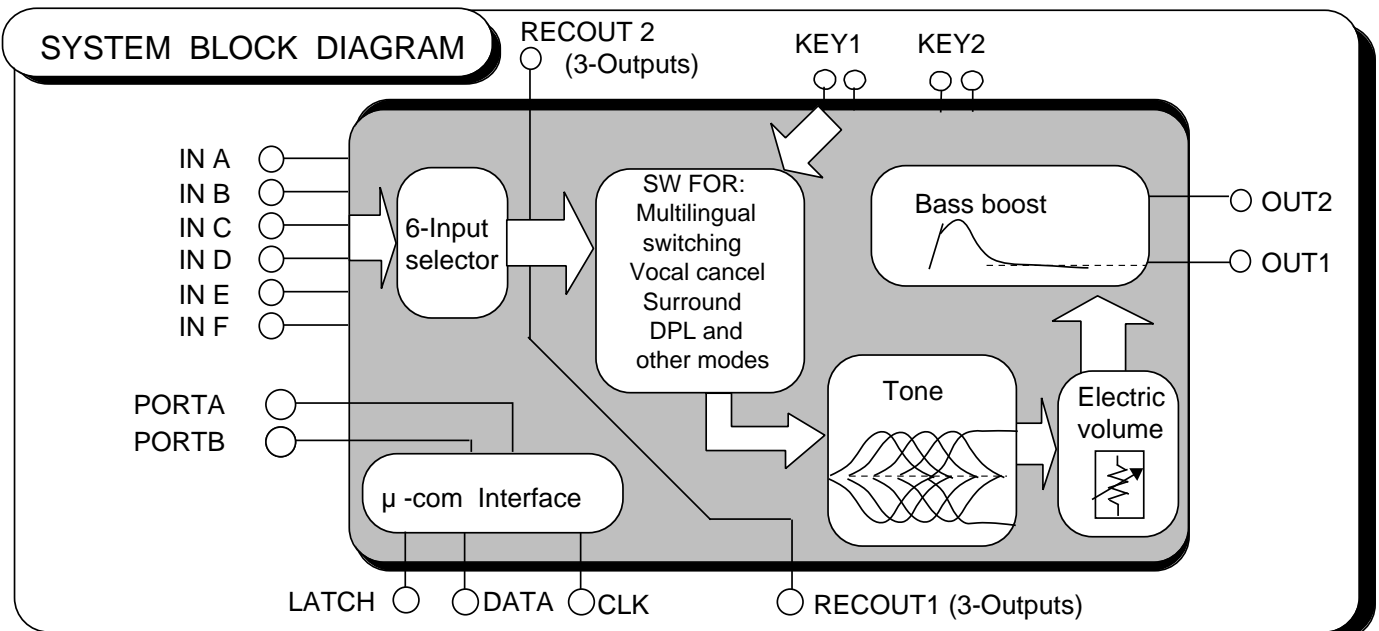

**PRELIMINARY**  
 Notice ; This is not a final specification.  
 some parametric limits are subject to change.

MITSUBISHI SOUND PROCESSORS

# M62433FP

DIGITAL SOUND CONTROLLER

IC Internal Block Diagram

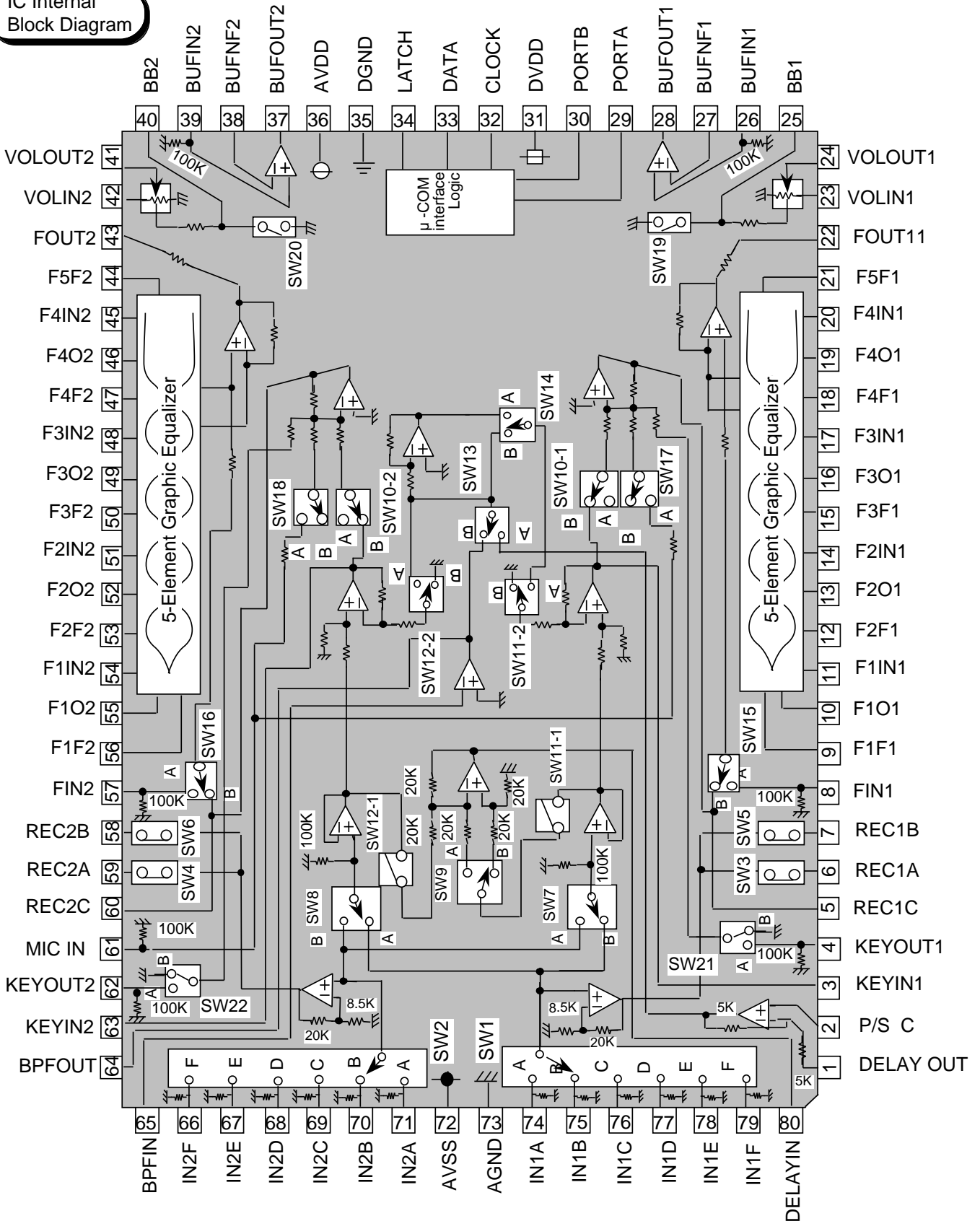

**PRELIMINARY**  
 Notice ; This is not a final specification.  
 some parametric limits are subject to change.

MITSUBISHI SOUND PROCESSORS

# M62433FP

DIGITAL SOUND CONTROLLER

## Pin Description

Pin No.	Symbol	Function	
72	AVSS	Negative power supply to internal analog circuit	
73	AGND	GND of internal analog circuit	
74,75,76 77,78,79	IN1A,IN1B,IN1C IN1D,IN1E,IN1F	Input pin at the side of channel1	
71,70,69 68,67,66	IN2A,IN2B,IN2C IN2D,IN2E,IN2F	Input pin at the side of channel2	
80	DELAYIN	(R-L) output pin for surround. Connected to the input of delay circuit. Total load resistance is 20k	
1	DELAYOUT	(R-L) input pin for surround. Connected to the output of delay circuit.	
2	P/S C	Phase shift filter pin for surround	
3,63	KEYIN1 KEYIN2	Key control adapter output pin. Connected to the input of key control circuit etc. Total load resistance is 20k	
4,62	KEYOUT1 KEYOUT2	Key control adapter input pin. Connected to the output of key control circuit	
64	BPFOUT	Band-pass filter amplifier output pin for voice cancel	
65	BPFIN	Band-pass filter amplifier input pin for voice cancel	
5,60	REC1A REC2A	Rec output pin A	
6,59	REC1B REC2B	Rec output pin B (with mute SW)	total load resistance ; min. 20K
7,58	REC1C REC2C	Rec output pin C (with mute SW)	
8,57	FIN1 FIN2	Tone input pin (Surround adapter OUT)	
9,46	F1F1 F1F2	Pin for connecting resonance impedance (band filter) of the 1st element	
10,45	F1O1 F1O2	Output pin of resonance buffer amplifier of the 1st element	
11,54	F1IN1 F1IN2	Input pin of resonance buffer amplifier of the 1st element	
12,53	F2F1 F2F2	Pin for connecting resonance impedance (band filter) of the 2nd element	
13,52	F2O1 F2O2	Output of resonance buffer amplifier of the 2nd element	

**PRELIMINARY**  
 Notice ; This is not a final specification.  
 some parametric limits are subject to change.

MITSUBISHI SOUND PROCESSORS

# M62433FP

DIGITAL SOUND CONTROLLER

Pin No.	Symbol	Function
14,51	F2IN1 F2IN2	Input pin of resonance buffer amplifier of the 2nd element
15,50	F3F1 F3F2	Pin for connecting resonance impedance (band filter) of the 3rd element
16,49	F3O1 F3O2	Output pin of resonance buffer amplifier of the 3rd element
17,48	F3IN1 F3IN2	Input pin of resonance buffer amplifier of the 3rd element
18,47	F4F1 F4F2	Pin for connecting resonance impedance (band filter) of the 4th element
19,46	F4O1 F4O2	Output pin of resonance buffer amplifier of the 4th element
20,45	F4IN1 F4IN2	Input pin of resonance buffer amplifier of the 4th element
21,44	F5F1 F5F2	Pin for connecting band filter of the 5th element
22,43	FOUT1 FOUT2	Tone output pin. Capacitor is combined for connection with the next stage.
23,42	VOLIN1 VOLIN2	R-ladder volume input pin
24,41	VOLOUT1 VOLOUT2	R-ladder volume output pin
25,40	BB11 BB12	Bass boost capacitance connection pin. Sets frequency characteristics.
26,39	BUFIN1 BUFIN2	+input pin of bass boost output amplifier
27,38	BUFNF1 BUFNF2	-input pin of bass boost output amplifier
28,37	BUFOUT1 BUFOUT2	Output pin of bass boost output amplifier
29	PORTA	Output of port A
30	PORTB	Output of port B
31	DVDD	Power supply to internal logic circuit
32	CLOCK	Clock input pin for serial data transfer
33	DATA	Input pin of control data. Reads data at the rising edge of clock.

**PRELIMINARY**  
Notice ; This is not a final specification.  
some parametric limits are subject to change.

MITSUBISHI SOUND PROCESSORS

# M62433FP

DIGITAL SOUND CONTROLLER

---

Pin No.	Symbol	Function
34	LATCH	Input pin of latch signal. The circuit status changes at the rising edge of latch signal.
35	DGND	GND pin of internal logic circuits
36	AVDD	Positive power supply pin of internal analog circuits
61	MIC IN	Microphone input pin

**PRELIMINARY**  
 Notice ; This is not a final specification.  
 some parametric limits are subject to change.

MITSUBISHI SOUND PROCESSORS

# M62433FP

DIGITAL SOUND CONTROLLER

## ABSOLUTE MAXIMUM RATINGS

Symbol	Parameter	Conditions	Ratings	Unit
AVDD,AVSS	Analog Power supply		±7.5	V
DVDD	Digital Power supply		6.0	V
Pd	Power dissipation	Ta _ 25°C	1370	mW
Kθ	Thermal derating	Ta > 25°C Attached PC Board*	13.7	mW/°C
Topr	Operating temperature		-20 ~ +75	°C
Tstg	Storage temperature		-55 ~ +125	°C

Thermal derating  
 (Maximum ratings)

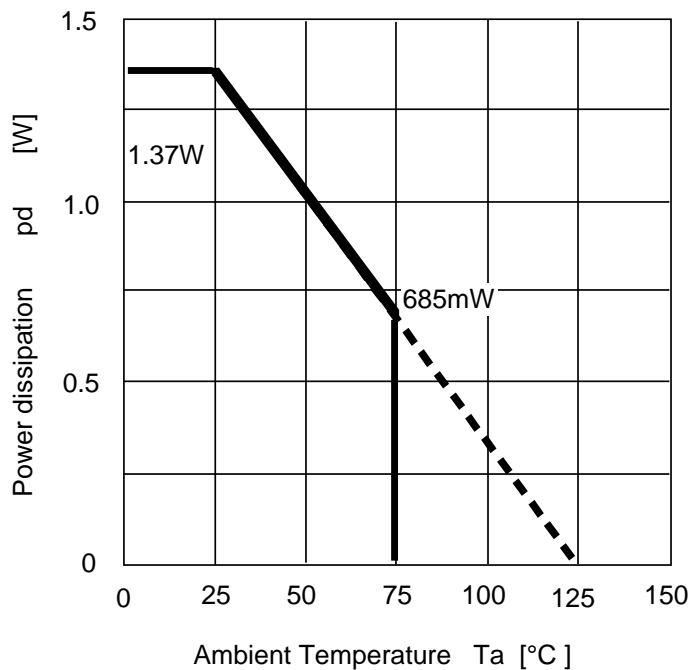

\*Note : PC Board

- PC Board Size  
140 mm X140 mm
- PC Board Thickness  
1.6 mm
- PC Board Material  
Epoxy
- Copper Film Thickness  
18 μm
- Copper Foil Size  
0.25 mm X 50 mm

**PRELIMINARY**  
 Notice ; This is not a final specification.  
 some parametric limits are subject to change.

# M62433FP

## RECOMMENDED OPERATING CONDITIONS

( Ta=25°C, unless otherwise noted )

Parameter	Symbol	Conditions	MIN	TYP	MAX	Unit
Analog (+) power supply	AVDD	Note 1	4.5	7.0	7.3	V
Analog (-) power supply	AVSS	Note 1	-4.5	-7.0	-7.3	V
Digital power supply	DVDD	DVDD_AVDD	4.5	5.0	5.5	V
Logic "H" Level input voltage	VIH		DVDD-0.7	—	VDD	V
Logic "L" Level input voltage	VIL		0	—	DGND+0.7	V

Note 1: The sequence of the power supply is as follows.  
 AVDD → AVSS → DVDD

## TIMING DIAGRAM

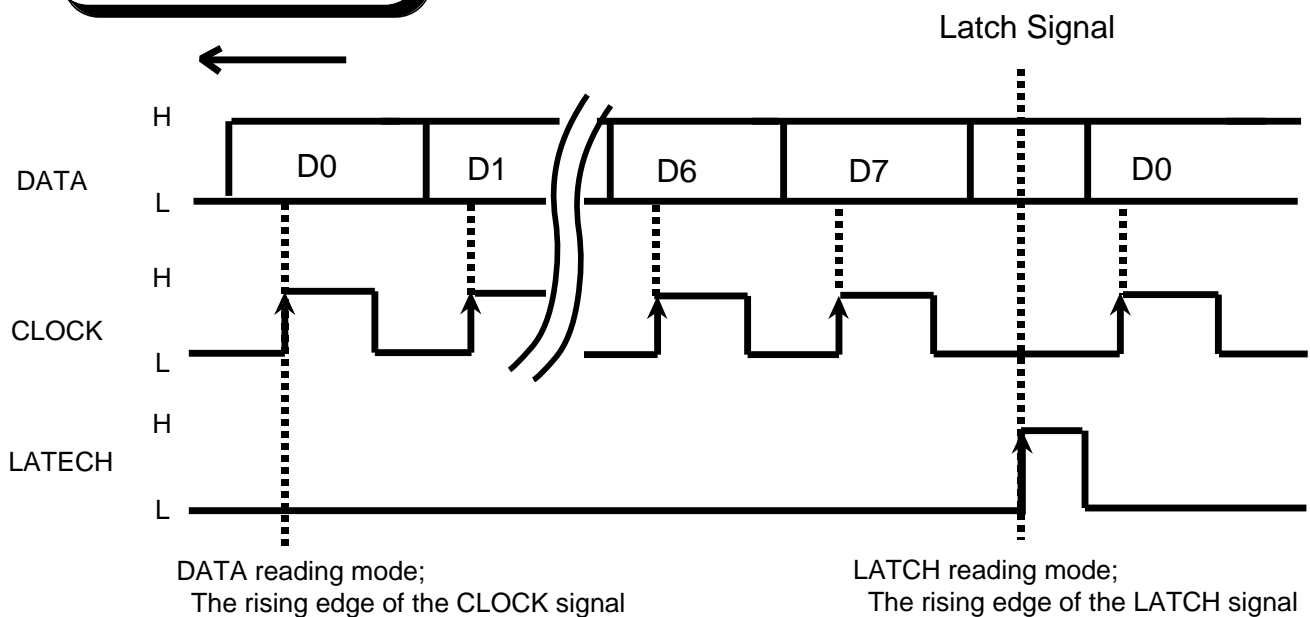

**PRELIMINARY**  
 Notice ; This is not a final specification.  
 some parametric limits are subject to change.

MITSUBISHI SOUND PROCESSORS

# M62433FP

DIGITAL SOUND CONTROLLER

## CLOCK DATA TIMING

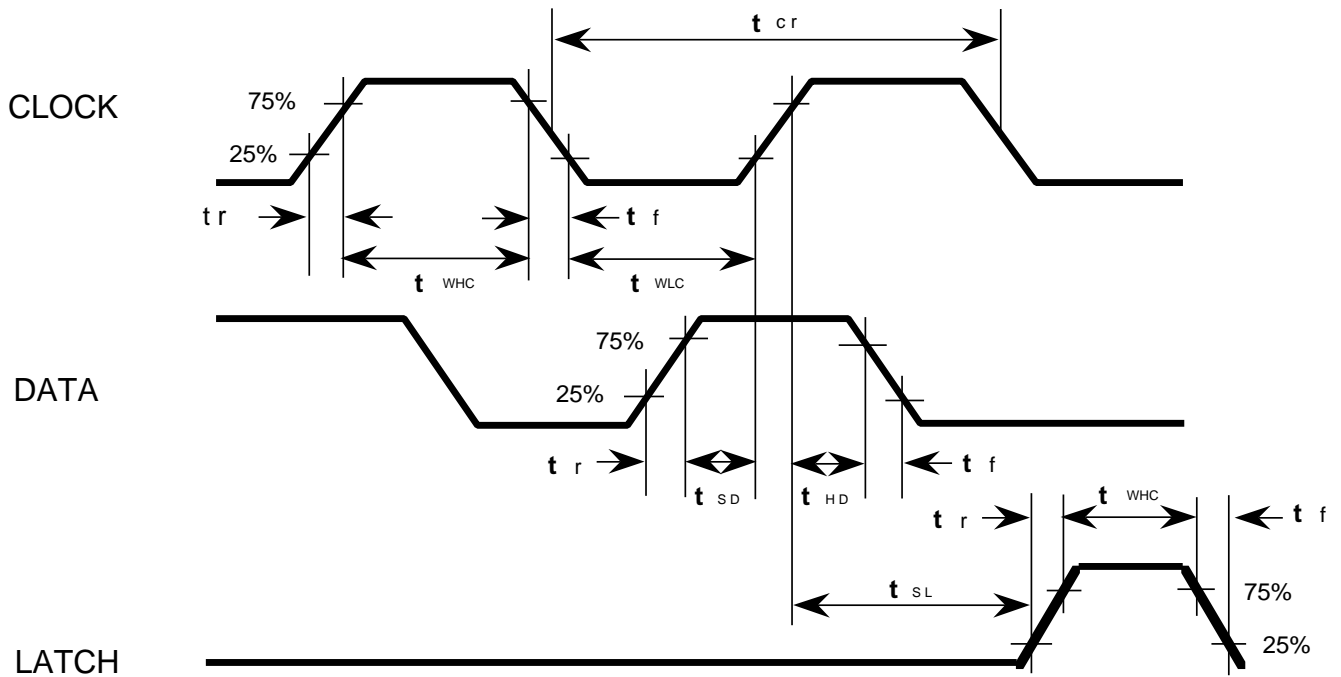

## DIGITAL CIRCUIT AC CHARACTERISTICS

Symbol	Parameter	Limits			Unit
		Min	typ	Max	
$t_{cr}$	CLOCK cycle time	4	-	-	$\mu$ sec
$t_{WHC}$	CLOCK pulse width ( " H " level )	1.6	-	-	
$t_{WLC}$	CLOCK pulse width ( " L " level )	1.6	-	-	
$t_r$	CLOCK, DATA, LATCH rise time	-	-	0.4	
$t_f$	CLOCK, DATA, LATCH fall time	-	-	0.4	
$t_{SD}$	DATA setup time	0.8	-	-	
$t_{HD}$	DATA hold time	0.8	-	-	
$t_{SL}$	LATCH setup time	1	-	-	
$t_{WHL}$	LATCH pulse width	1.6	-	-	



**PRELIMINARY**  
 Notice ; This is not a final specification.  
 some parametric limits are subject to change.

# M62433FP

## DATA FORMAT

4 patterns input formats can be selected by setting D6 and D7.

( When the IC is powered up, the internal settings are not fixed. )



( 1 )

DO1	D11	D21	D31	D41	D51	D6	D7
Rec out A S W 3,4 1 : Mute 0 : Pass	Rec out B S W 5,6 1 : Mute 0 : Pass	For the multiplex software S W 7 1 : A side 0 : B side	S W 8 1 : A side 0 : B side	S W 9 1 : A side 0 : B side	S W 10-1 S W 10-2 1 : ON 0 : OFF	0	0

( 2 )

DO2	D12	D22	D32	D42	D52	D6	D7
S W 11-1,2 S W 12-1,2 1:Aside/ON 0:Bside/OFF	S W 13 1 : A side 0 : B side	S W 21,22 1 : A side 0 : B side	S W 14 1 : A side 0 : B side	S W 17,18 1 : A side 0 : B side	S W 15,16 1 : A side 0 : B side	0	1

( 3 )

DO3	D13	D23	D33	D43	D53	D6	D7
※ For Tone control (element) Refer to the Tone Control 1 Code			※ For Tone control (gain) Refer to the Tone Control 2 Code			1	0
Bass Boost SW15,16 A / B							

( 4 - 1 )

DO4-1	D14-1	D24-1	D34-1	D44-1	D54-1	D6-1	D7-1
※ For Master Volume Refer to the Master Volume Code					0	1	1

( 4 - 2 )

DO4-2	D14-2	D24-2	D34-2	D44-2	D54-2	D6-2	D7-2
※ For Input selector Refer to the Input selector Code					1	1	1

( 5 ) Tone control 1 code (element)

		D03	D13	D23
Tone 1 (F1)		0	0	1
Tone 2 (F2)		0	1	0
Tone 3 (F3)		0	1	1
Tone 4 (F4)		1	0	0
Tone 5 (F5)		1	0	1
Bass Boost	ON	1	1	0
	OFF	1	1	1

( 6 ) Tone control 2 code (gain)

		D33	D43	D53
Boost	+0 dB	0	0	0
	+3 dB	0	0	1
	+6 dB	0	1	0
	+9 dB	0	1	1
Cut	-0 dB	1	0	0
	-3 dB	1	0	1
	-6 dB	1	1	0
	-9 dB	1	1	1

**PRELIMINARY**  
 Notice ; This is not a final specification.  
 some parametric limits are subject to change.

# M62433FP

( 7 ) Master volume code

A T T	D04	D14	D24	D34	D44
- 0.0 dB	0	0	0	0	0
- 2.0 dB	1	0	0	0	0
- 4.0 dB	0	1	0	0	0
- 6.0 dB	1	1	0	0	0
- 8.0 dB	0	0	1	0	0
-10.0 dB	1	0	1	0	0
-12.0 dB	0	1	1	0	0
-14.0 dB	1	1	1	0	0
-16.0 dB	0	0	0	1	0
-18.0 dB	1	0	0	1	0
-20.0 dB	0	1	0	1	0
-22.0 dB	1	1	0	1	0
-24.0 dB	0	0	1	1	0
-26.0 dB	1	0	1	1	0
-28.0 dB	0	1	1	1	0
-30.0 dB	1	1	1	1	0
-32.0 dB	0	0	0	0	1
-34.0 dB	1	0	0	0	1
-36.0 dB	0	1	0	0	1
-38.0 dB	1	1	0	0	1
-40.0 dB	0	0	1	0	1
-44.0 dB	1	0	1	0	1
-48.0 dB	0	1	1	0	1
-52.0 dB	1	1	1	0	1
-56.0 dB	0	0	0	1	1
-60.0 dB	1	0	0	1	1
-64.0 dB	0	1	0	1	1
-68.0 dB	1	1	0	1	1
-72.0 dB	0	0	1	1	1
-76.0 dB	1	0	1	1	1
-80.0 dB	0	1	1	1	1
-	1	1	1	1	1

( 8 ) Port output code

DATA		Port output
D 32-2	0	Port A : L
	1	Port A : H
D 44-2	0	Port B : L
	1	Port B : H

( 9 ) Multilingual record code

	D21	D31
Normal	0	0
Lch only	0	1
Rch only	1	0
R/L Exchange	1	1

( 10 ) Input selector code

Selector	D14-2	D14-2	D24-3
A	0	0	0
B	0	0	1
C	0	1	0
D	0	1	1
E	1	0	0
F	1	1	0
All off	1	1	1

( 11 ) The others code

For voice cancel	
D41=1	SW9 : A side
D02=1	SW11,12-1 : ON
	SW11,12-2 : A side
D12=0	SW13 : B side
D32=0	SW14 : B side

For Surround	
D41=0	SW9 : B side
D02=1	SW11,12-1 : ON
	SW11,12-2 : A side
D12=1	SW13 : A side
D32=1	SW14 : A side

MODE	SW21,22	SW17,18	SW10-1 SW10-2	SW15,16
NORMAL STEREO	B side	B side	B side	B side
STEREO + MIC	B side	A side	B side	B side
MIX MODE (Source + Key control)	A side	A side	B side	B side
KEY CONTROL MODE	A side	A side	A side	B side
DPL MODE	B side	B side	A side	A side

**PRELIMINARY**  
 Notice ; This is not a final specification.  
 some parametric limits are subject to change.

# M62433FP

## ELECTRICAL CHARACTERISTICS

( Ta=25°C, AVDD=7.0V, AVSS=-7.0V, DVDD=5.0V , f=1kHz  
 Tone control & Bass Boost setting :0dB , unless otherwise noted )

### ( 1 ) Power supply

Parameter	Symbol	Conditions	Limits			Unit
			Min	typ	Max	
Circuit current (Analog +)	Aldd	AVDD=7.0V, AVSS= -7.0V ISINK of 36pin No signal input	-	40	48	mA
Circuit current (Analog -)	AIss	AVDD=7.0V, AVSS= -7.0V ISOURCE of 72pin No signal input	-48	-40	-	mA
Circuit current (Digital )	Dldd	DVDD= 5V ISINK of 31pin No signal input	-	0.5	1.0	mA

### ( 2 ) Input/Output

Parameter	Symbol	Conditions	Limits			Unit	
			Min	typ	Max		
Input impedance	Rin	66 ~ 71pin, 74 ~ 79Pin, Ta=25°C	20	47	100	K	
Maximum input voltage	VIM	(66 ~ 71pin input), (74 ~ 79pin input) 28,37pin output RL =4.7K , THD=1%	3.0	4.0	—	Vrms	
Output terminal voltage	Vodc	28pin, 37pin, No input signal	-0.1	0	0.1	V	
	Vrecdc	5pin, 60pin, No input signal	-0.1	0	0.1	V	
I/O voltage gain	Gv	Vin=1Vrms, FLAT, (66 ~ 71Pin), (74 ~ 79Pin)-28,37Pin	10.0	12.0	14.0	dB	
Output noise voltage	Vono	JIS-A filter No input signal Rg=10K	28,37pin ATT0	—	55.0	70.0	μ Vrms
			ATTM	—	5.0	15	μ Vrms
	Vrecno	FLAT	6,59pin 7,58pin	—	20.0	30	μ Vrms
Distortion	THD	28pin, 37pin, BW=400 ~ 30kHz Vi = -20dBv , RL=4.7K	—	0.01	0.05	%	
	THDrecB,C	(6,59pin), (7,58pin), BW400 ~ 30kHz Vi = -20dBv , RL=20K	—	0.01	0.05	%	
Channel separation	CT	Vo=0.5Vrms , RL=4.7K , JIS-A 28pin—37pin Rg=0K , 61pin GND	—	-75	-55	dB	
	CTrec	Vo=0.5Vrms , RL=20K , JIS-A 6pin—59pin Rg=0K , 61pin GND	—	-75	-55	dB	

**PRELIMINARY**  
 Notice ; This is not a final specification.  
 some parametric limits are subject to change.

# M62433FP

### ( 3 ) Tone Control

Parameter	Symbol	Conditions	Limits			Unit	
			Min	typ	Max		
Voltage gain (Tone control)	Gboost1	3dB	f=1KHz,Vo=1Vrms Input ;8pin,57pin Output ;22pin,43pin	1.5	3	4.5	dB
	Gboost2	6dB		4.5	6	7.5	dB
	Gboost3	10dB		8.0	10	12.0	dB
	Gcut1	-3dB		-4.5	-3	-1.5	dB
	Gcut2	-6dB		-7.5	-6	-4.5	dB
	Gcut3	-10dB		-12.0	-10	-8.0	dB
Balance between channels	BALton	f=1KHz,Vo=1Vrms, Input;8,57Pin Output;22,43Pin +10dB and -10dB	-1.5	0	+1.5	dB	

### ( 4 ) Bass Boost

Parameter	Symbol	Conditions	Limits			Unit
			Min	typ	Max	
Voltage gain (Bass boost)	Gboost	f=70Hz,Vo=0.5Vrms Input ; 23,42pin Output ; 27,38pin	-10	-6	-2	dB
Balance between channels	BALton	f=70Hz ,Vo=0.5Vrms Input ; 23,42Pin Output ; 27,38pin, Bass boost ON	-2.0	0	+2.0	dB

### ( 5 ) PORT OUTPUT

Parameter	Symbol	Conditions	Limits			Unit
			Min	typ	Max	
Minimum "H" voltage	VpHA	RL=1.8k	5.4	6.0	—	V
	VpHB					
Maximum "L" leak current	IpLA		-3	0	3	uA
	IpLA					
Maximum drive current	IpD		—	0.7	3	mA

**PRELIMINARY**  
 Notice ; This is not a final specification.  
 some parametric limits are subject to change.

MITSUBISHI SOUND PROCESSORS

# M62433FP

DIGITAL SOUND CONTROLLER

## Master volume circuit

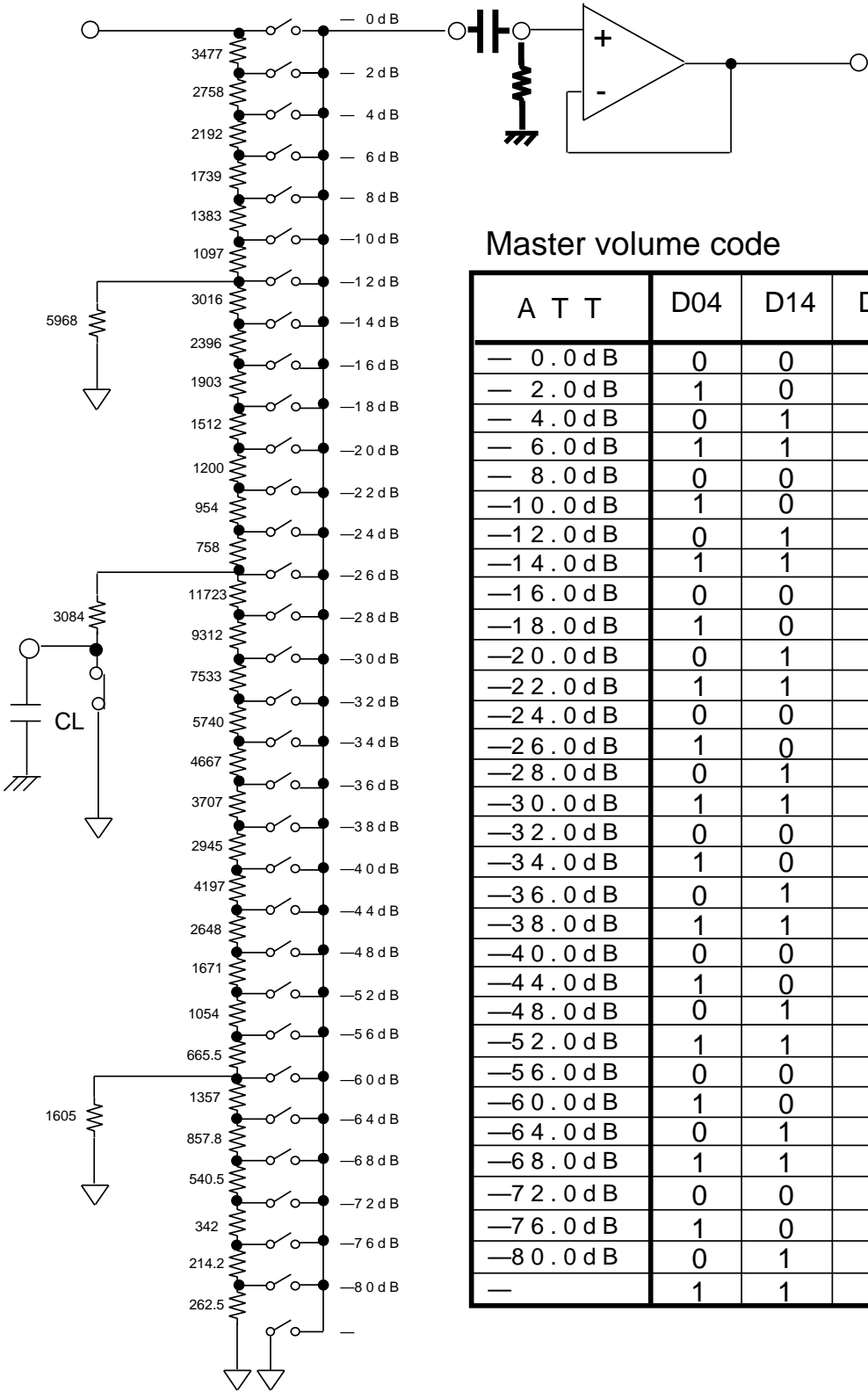

Master volume code

A T T	D04	D14	D24	D34	D44
- 0.0 dB	0	0	0	0	0
- 2.0 dB	1	0	0	0	0
- 4.0 dB	0	1	0	0	0
- 6.0 dB	1	1	0	0	0
- 8.0 dB	0	0	1	0	0
-10.0 dB	1	0	1	0	0
-12.0 dB	0	1	1	0	0
-14.0 dB	1	1	1	0	0
-16.0 dB	0	0	0	1	0
-18.0 dB	1	0	0	1	0
-20.0 dB	0	1	0	1	0
-22.0 dB	1	1	0	1	0
-24.0 dB	0	0	1	1	0
-26.0 dB	1	0	1	1	0
-28.0 dB	0	1	1	1	0
-30.0 dB	1	1	1	1	0
-32.0 dB	0	0	0	0	1
-34.0 dB	1	0	0	0	1
-36.0 dB	0	1	0	0	1
-38.0 dB	1	1	0	0	1
-40.0 dB	0	0	1	0	1
-44.0 dB	1	0	1	0	1
-48.0 dB	0	1	1	0	1
-52.0 dB	1	1	1	0	1
-56.0 dB	0	0	0	1	1
-60.0 dB	1	0	0	1	1
-64.0 dB	0	1	0	1	1
-68.0 dB	1	1	0	1	1
-72.0 dB	0	0	1	1	1
-76.0 dB	1	0	1	1	1
-80.0 dB	0	1	1	1	1
-	1	1	1	1	1

**PRELIMINARY**  
 Notice ; This is not a final specification.  
 some parametric limits are subject to change.

# M62433FP

**Function description**

( 1 ) Voice cancel block equivalent circuit

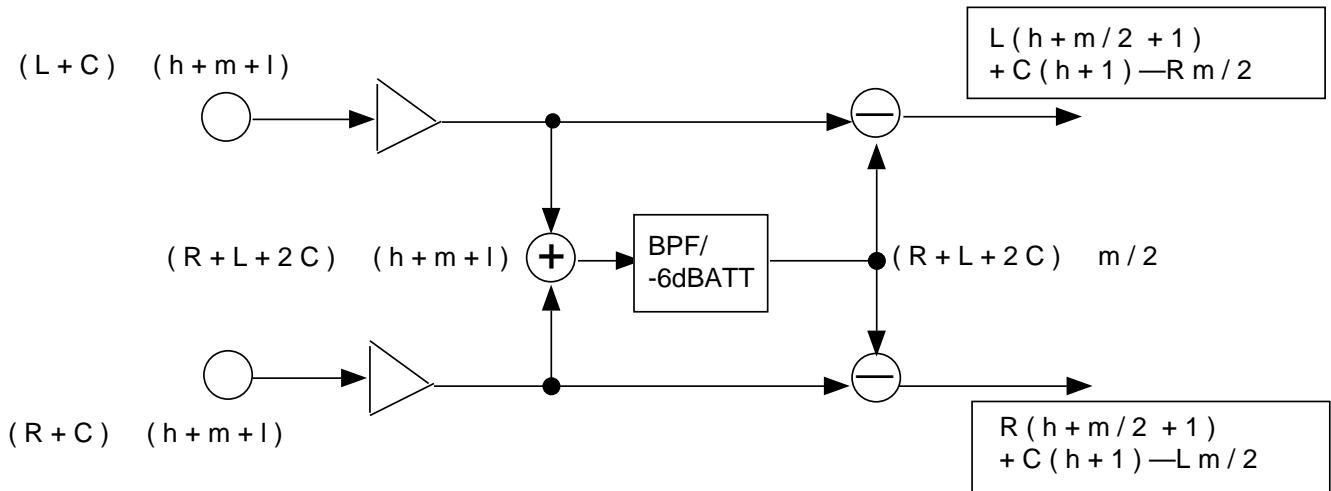

( 2 ) Surround block equivalent circuit

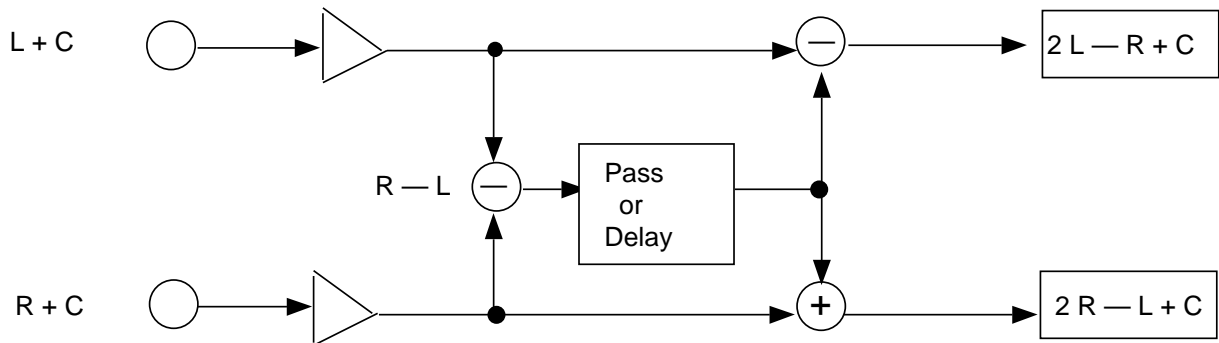

**PRELIMINARY**  
 Notice ; This is not a final specification.  
 some parametric limits are subject to change.

# M62433FP

### ( 3 ) Tone control equivalent circuit

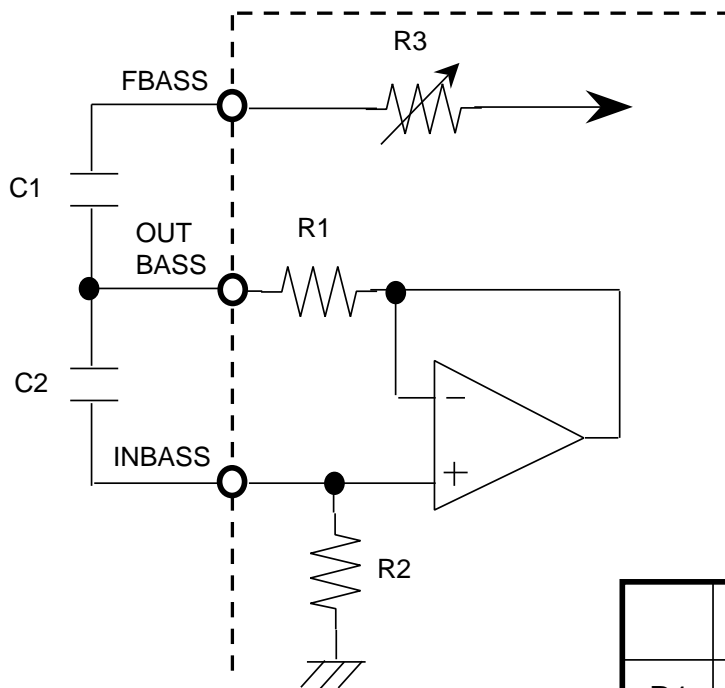

Center frequency

$$f_0 = 1 / 2 \sqrt{C1 \cdot C2 \cdot R1 \cdot R2} \text{ [Hz]}$$

$$Q = \sqrt{(C2 \cdot R2) / C1 (C1 + R1)}$$

Example; Bass band ( f=150Hz )

R1=1.5K , R2=56K

C1=1.5 μ, C2=0.01 μ

	F1	F2	F3	F4	F5
R1	1.0k	1.0k	1.0k	1.0k	—
R2	300k	300k	300k	150k	—

Fig.1 The equivalent circuit of tone controller

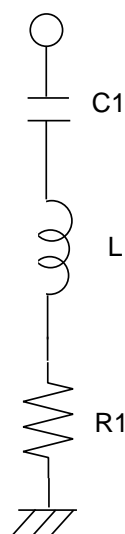

Fig.2 is equivalent to Fig.1  
 To convert component constants,  
 the equation below is used.

$$L = C2 \cdot R1 \cdot R2$$

Fig.12 The equivalent circuit using L

**PRELIMINARY**  
 Notice ; This is not a final specification.  
 some parametric limits are subject to change.

# M62433FP

## ( 4 ) Bass boost equivalent circuit

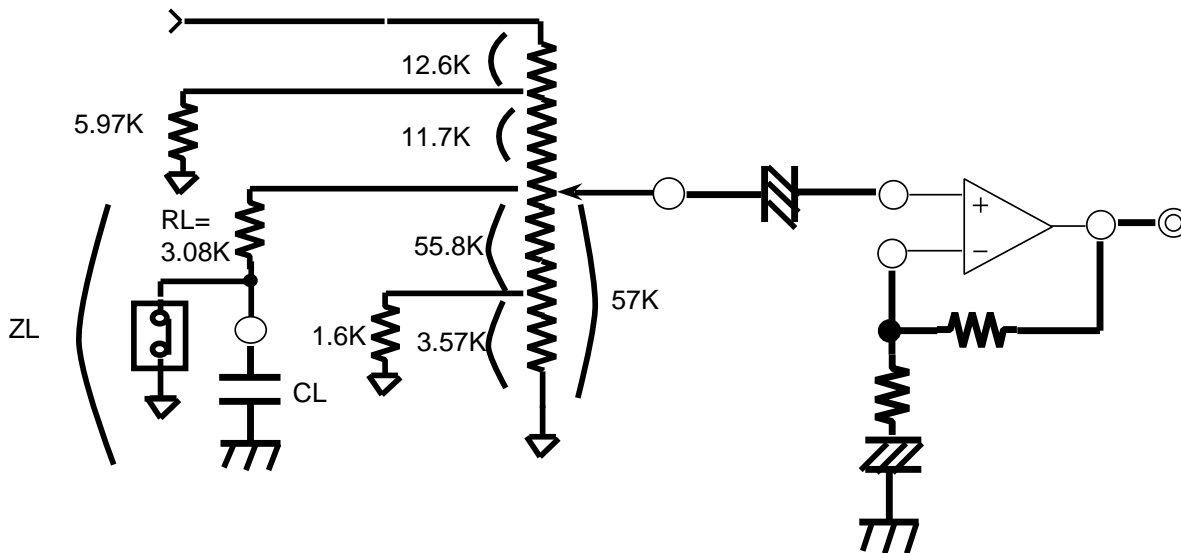

Bass Boost loudness equivalent circuit (Center tap type)

Regard " $RL + \frac{1}{\omega \cdot CL}$ " as "ZL"

Next formula show the frequency characteristic.

$$G_v = 20 \text{ Log} \left[ \frac{ZL // 57K}{11.7K + ZL // 57K} \cdot \frac{5.97K // [11.7K + ZL // 57K]}{12.6K + 5.97K // [11.7K + ZL // 57K]} \right]$$

When a frequency is enough low ,

$$G_v = 20 \text{ Log} \left[ \frac{57K}{11.7K + 57K} \cdot \frac{5.97K // [11.7K + 57K]}{12.6K + 5.97K // [11.7K + 57K]} \right] = -11.9 \text{ dB}$$

When a frequency is enough high ,

$$G_v = 20 \text{ Log} \left[ \frac{3.08K // 57K}{11.7K + 3.08K // 57K} \cdot \frac{5.97K // [11.7K + 3.08K // 57K]}{12.6K + 5.97K // [11.7K + 3.08K // 57K]} \right] = -26 \text{ dB}$$

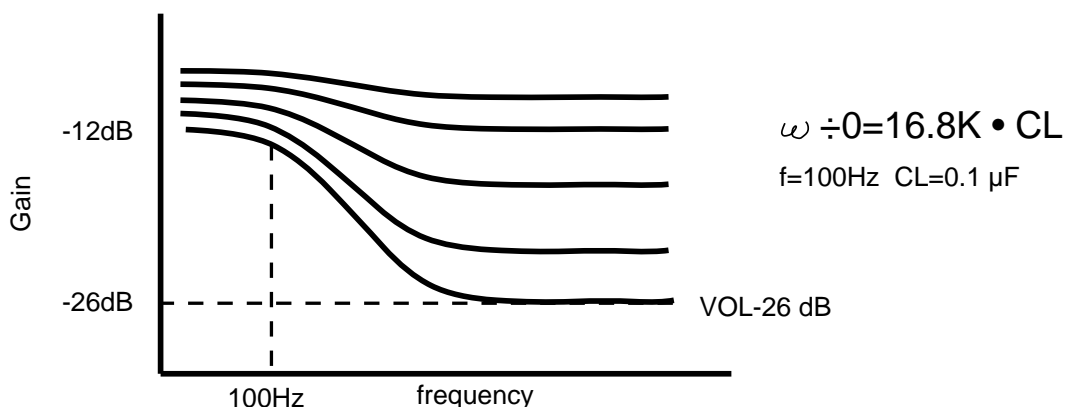



**PRELIMINARY**  
 Notice ; This is not a final specification.  
 some parametric limits are subject to change.

MITSUBISHI SOUND PROCESSORS

# M62433FP

DIGITAL SOUND CONTROLLER

### ( 3 ) Band-Pass filter block equivalent circuit

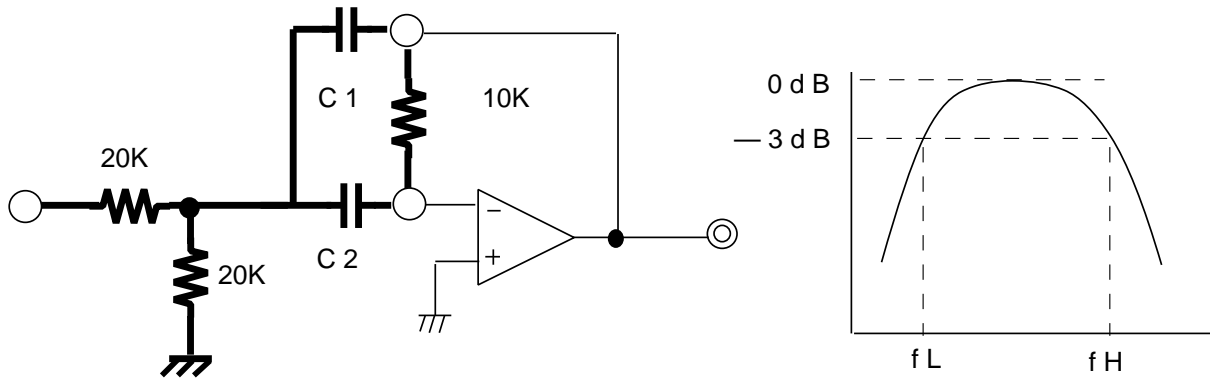

( The equation for band-pass filter )

$$f H \text{ [ cut-off frequency ]} \quad \frac{1}{2 C 1 \cdot 10 K}$$

High frequency's side

$$f L \text{ [ cut-off frequency ]} \quad \frac{1}{2 C 2 \cdot 10 K}$$

Low frequency's side

**PRELIMINARY**  
 Notice ; This is not a final specification.  
 some parametric limits are subject to change.

MITSUBISHI SOUND PROCESSORS

# M62433FP

DIGITAL SOUND CONTROLLER

The block diagram along the signal flow (No.1)

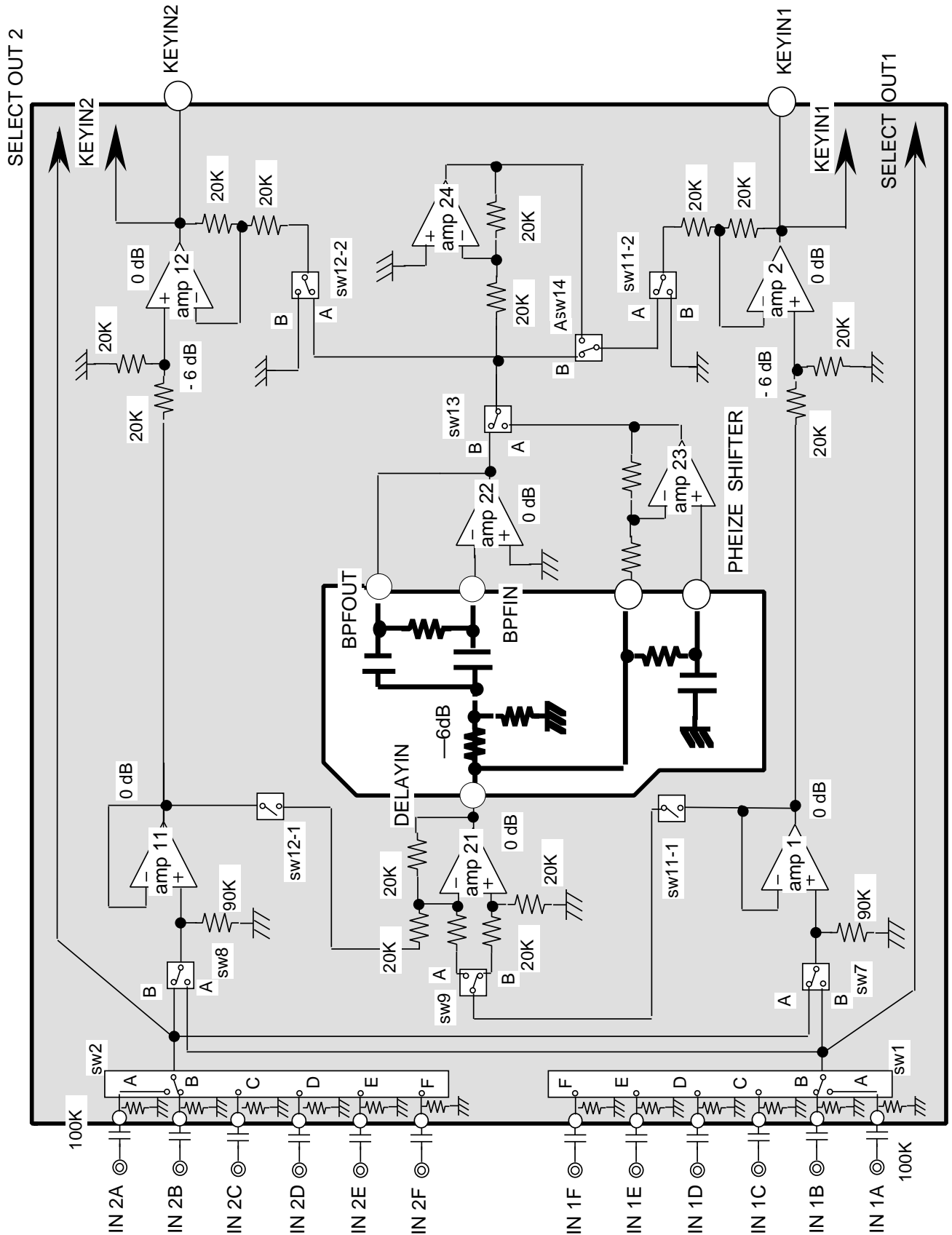

**PRELIMINARY**  
 Notice ; This is not a final specification.  
 some parametric limits are subject to change.

MITSUBISHI SOUND PROCESSORS

# M62433FP

DIGITAL SOUND CONTROLLER

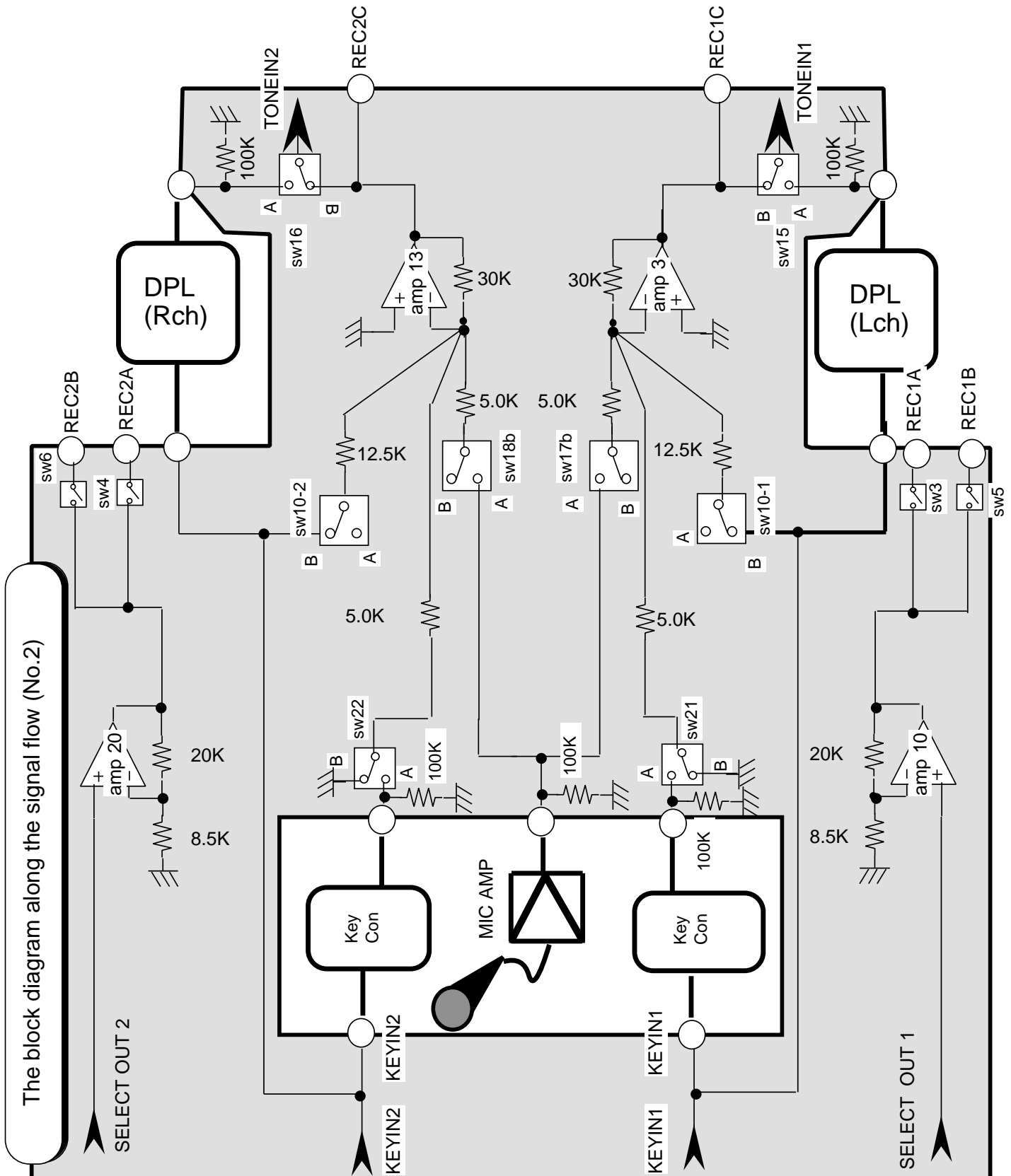

**PRELIMINARY**  
 Notice ; This is not a final specification.  
 some parametric limits are subject to change.

MITSUBISHI SOUND PROCESSORS

# M62433FP

DIGITAL SOUND CONTROLLER

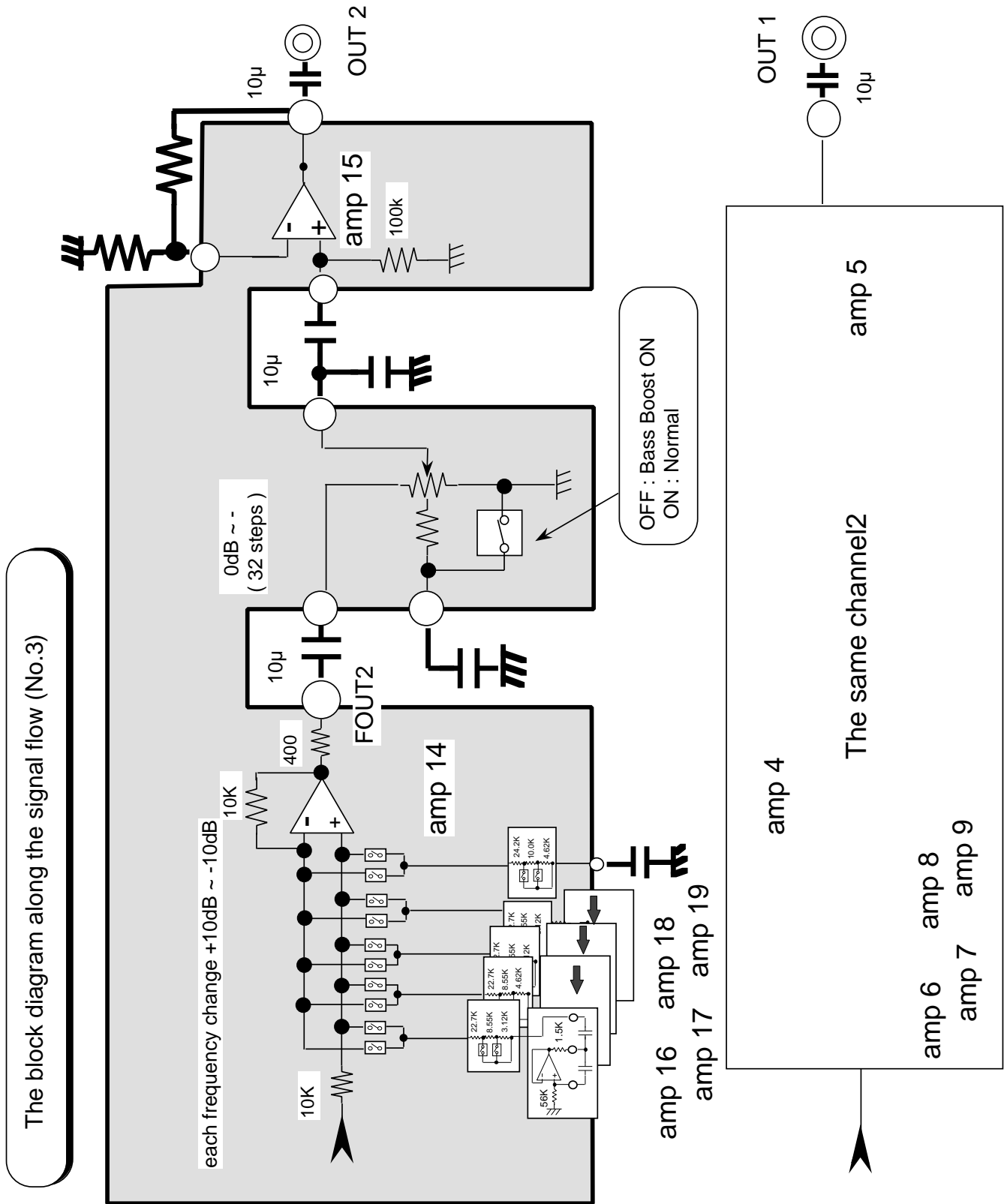

**PRELIMINARY**  
 Notice ; This is not a final specification.  
 some parametric limits are subject to change.

MITSUBISHI SOUND PROCESSORS

# M62433FP

DIGITAL SOUND CONTROLLER

