

M62496FP

ELECTRONIC VOLUME CONTROL WITH BUILT-IN SPEATEN FILTER

DESCRIPTION

The M62496FP is a sound controller IC for mini stereo component and radio cassette units. It has stereo enhancing processor Speaten filter. (Best suited for compact size speakers systems) As a result, the reproduced sound is much clear to a live performance. You can get several class high quality

Licensing and application information may be obtained from Dedekind Lab.
 The device available only to licensees of Dedekind Lab.
 Use of this IC requires the license of Dedekind Lab.(Tokushima C. Japan)

FEATURES

- Built-in 4ch input selector
- Variable volume range 0 to -83dB,- (1dB/step)
- Built-in bass boost circuit (loudness type)
- Built-in speaten filter (5 mode)
- 2band tone control
(0,±2.0,±4.0,±6.0,±8.0,±10.0,dB)
- Bass boost ON/OFF

PACKAGE

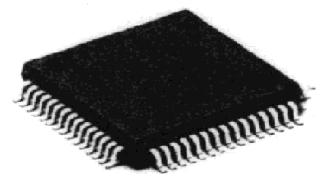

Outline 64P6N-A
 0.8mm pitch QFP
 (14.0mm X 14.0mm X 2.8mm)

RECOMMENDED OPERATING CONDITIONS

Analog supply voltage range ----- 6.0 to 9.0V
 Digital supply voltage range ----- 4.5 to 5.5V

SYSTEM CONFIGURATION

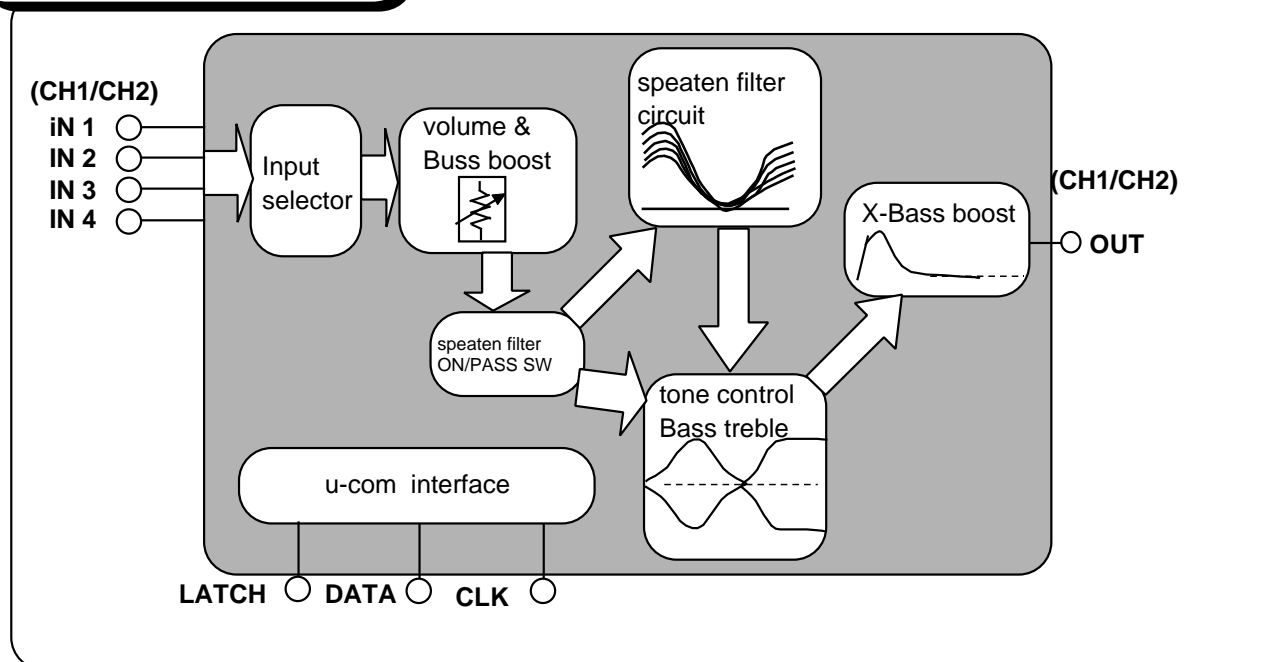

M62496FP

ELECTRONIC VOLUME CONTROL WITH BUILT-IN SPEAKEN FILTER

PIN CONFIGURATION(TOP VIEW)

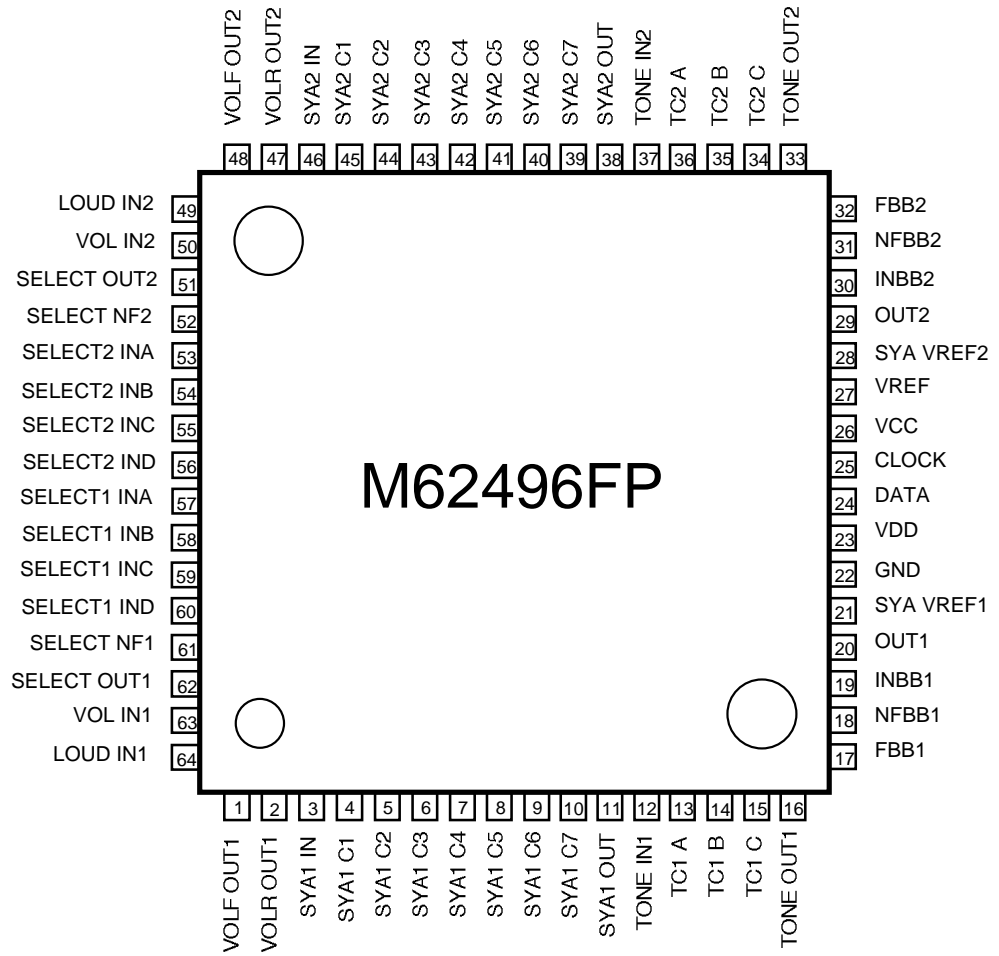

M62496FP

ELECTRONIC VOLUME CONTROL WITH BUILT-IN SPEATEN FILTER

IC INTERNAL BLOCK DIAGRAM

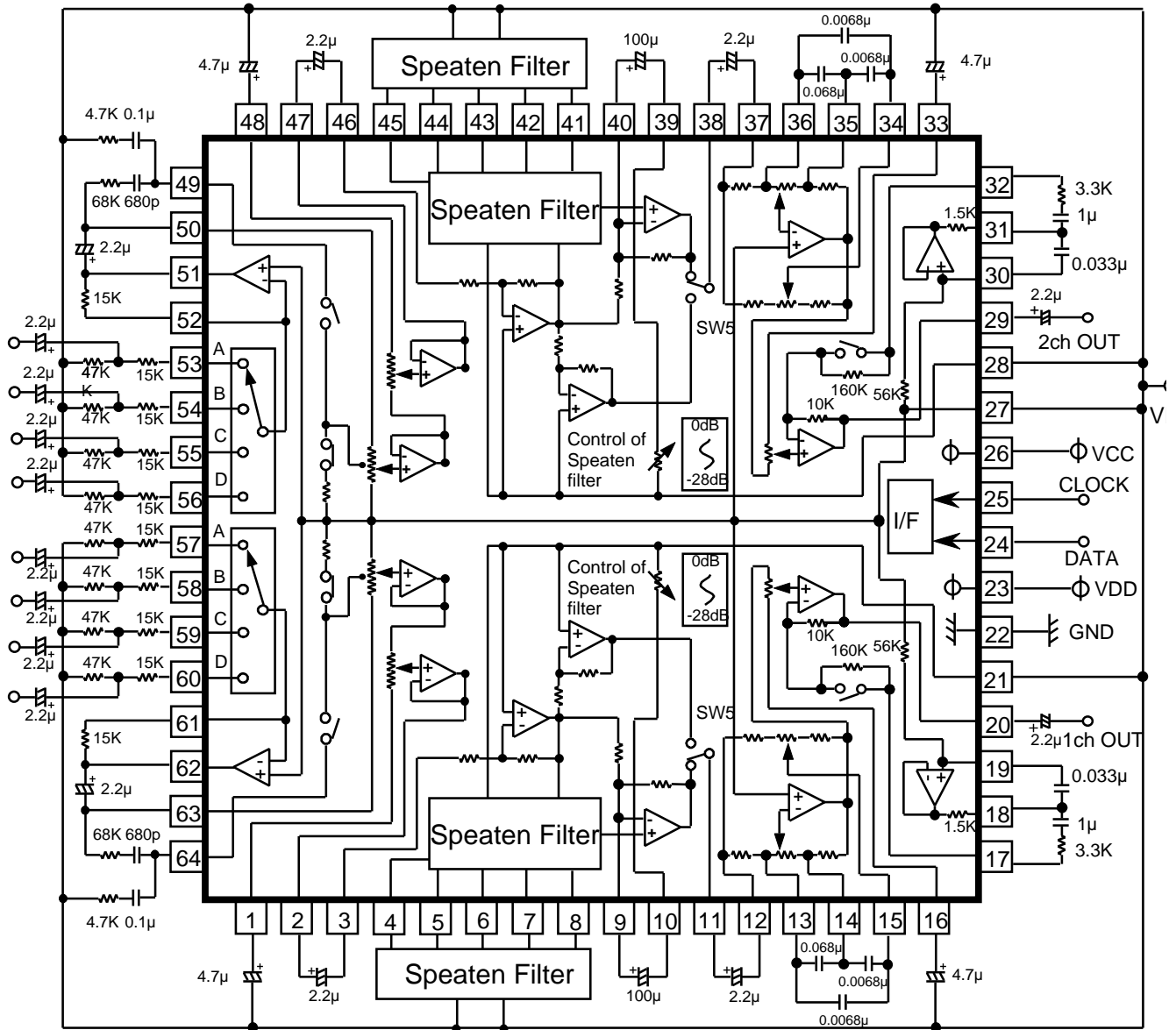

M62496FP**ELECTRONIC VOLUME CONTROL WITH BUILT-IN SPEATEN FILTER****PIN DESCRIPTION**

Pin No.	Symbol	Function
57	SELECT1 IN A	Input pin for channel 1 of the input selector switch block.
58	SELECT1 IN B	
59	SELECT1 IN C	
60	SELECT1 IN D	
53	SELECT2 IN A	Input pin for channel 2 1 of the input selector switch block.
54	SELECT2 IN B	
55	SELECT2 IN C	
56	SELECT2 IN D	
61	SELECT NF1	Adjusts input gains by using the resistance between this pin and the SELECT OUT pin and by using resistance added to INA to IND.
52	SELECT NF2	
62	SELECT OUT1	Output pin of the input selector switch.
51	SELECT OUT2	
63	VOL IN1	Input pin of the volume block.
50	VOL IN2	
64	LOUD IN1	Pin for setting the frequency characteristics of the loudness block.
49	LOUD IN2	
1	VOLF OUT1	Output pin of the volume block (1st stage). Connect this pin to VREF pin with C connection to reduce switching noise.
48	VOLF OUT2	
2	VOLR OUT1	Output pin of the volume block (2nd stage).
47	VOLR OUT2	
3	SYA1 IN	Input pin of the speaten filter block.
46	SYA2 IN	
4	SYA1 C1	Pin for connecting filter of the speaten filter. (ch1)
5	SYA1 C2	
6	SYA1 C3	
7	SYA1 C4	
8	SYA1 C5	
45	SYA2 C1	Pin for connecting filter of the speaten filter. (ch2)
44	SYA2 C2	
43	SYA2 C3	
42	SYA2 C4	
41	SYA2 C5	
9	SYA1 C6	Reduce switching noise on speaten filter effect by using the capacitance between pin9 and pin10.(ch1)
10	SYA1 C7	
40	SYA2 C6	Reduce switching noise on speaten filter effect by using the capacitance between pin39 and pin410.(ch2)
39	SYA2 C7	
11	SYA1 OUT	Output pin of the speaten filter block.
38	SYA2 OUT	
12	TONE IN1	Input pin of the tone control block.
37	TONE IN2	
13	TC1 A	Pin for setting frequency characteristics of the tone control block for channel 1.
14	TC1 B	
15	TC1 C	
36	TC2 A	Pin for setting frequency characteristics of the tone control block for channel 2.
35	TC2 B	
34	TC2 C	
16	TONE OUT1	Output pin of the tone control block.
33	TONE OUT2	
17	FBB1	Resonant impedance (band-pass filter) connection pin for base section.
32	FBB2	
18	NFBB1	Output pin of bass boosting resonant buffer amp.
31	NFBB2	
19	INBB1	Input pin of bass boosting resonant buffer amp.
30	INBB2	
20	OUT1	Final output pin of the ATT block.
29	OUT2	
21	SYA VREF1	Ground of the speaten filter speaten filter block. Apply 1/2Vcc.
28	SYA VREF2	
22	GND	Ground pin
23	VDD	Digital power supply pin.
24	DATA	Input pin of the control data. This pin inputs data in synchronization with CLOCK.
25	CLOCK	Clock input pin for serial data transfer.
26	VCC	Analog power supply pin.
27	VREF	IC signal ground. Apply 1/2Vcc.

M62496FP

ELECTRONIC VOLUME CONTROL WITH BUILT-IN SPEAKEN FILTER

ABSOLUTE MAXIMUM RATINGS

(Ta=25°C, unless otherwise noted)

Symbol	Parameter	Condition	Ratings	Unit
Vcc, VDD	Supply voltage		10.7	V
Pd	Power dissipation		1000	mW
Topr	Operating temperature		-20to+75	°C
Tstg	Storage temperature		-40to+125	°C

THERMAL DERATING

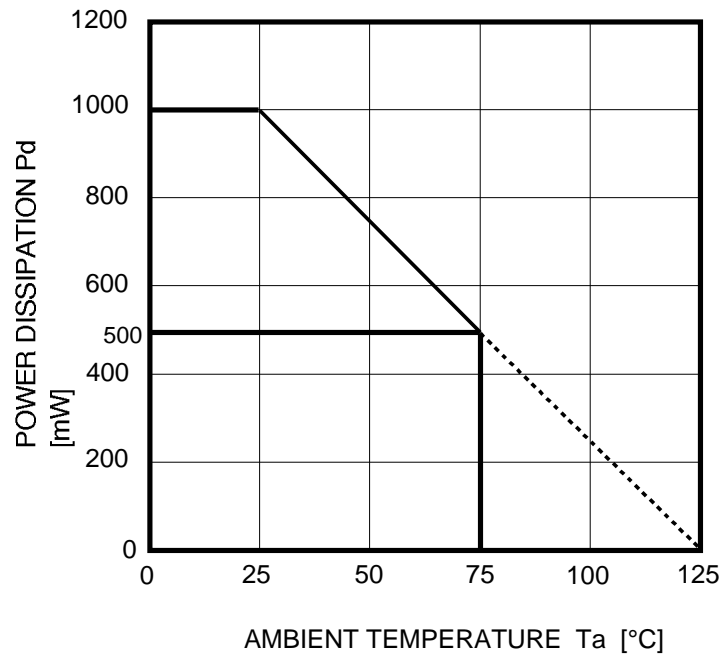

M62496FP**ELECTRONIC VOLUME CONTROL WITH BUILT-IN SPEATEN FILTER****ELECTRICAL CHARACTERISTICS**

(Ta=25°C, unless otherwise noted)

Symble	Parameter	Condition	Limits			Unit
			min	typ	max	
Supply voltage						
ICC	Circuit current	No signal	—	50	65	mA
IREF	REF input current	Speaten filter : MAX	—	3.2	6.0	mA
I/O (Output of selector)						
VOM(SEL)	Maximum output amplitude of selector amp	THD=1%	1.8	2.2	—	Vrms
VNO(SEL)	Output noise level of selector amp	Rg=0 DIN-Audio	—	5.5	11	μVrms
THD(SEL)	Total harmonic distortion of selector amp.	f=1KHz Vo=0.5Vrms DIN-Audio	—	0.003	0.05	%
CS(SEL)	Cannel separation of selector amp	f=1KHz DIN-Audio	—	-90	-80	dB
Volume						
ATT(VOL)	Maximum ATT of the main volume	ATT(VOL)=-	—	-90	-80	dB
△ATT(VOL)	△ ATT of the main volume	ATT(VOL)=0dB	-2	0	2	dB
I/O(total)						
VIM	Maximum input amplitude	THD=1%, Speaten filter : OFF VOL=-4dB ATT=0dB	2.0	2.8	—	Vrms
VOM	Maximum output amplitude	THD=1%, Speaten filter : ON	1.4	1.8	—	Vrms
		THD=1%, Speaten filter : OFF	1.8	2.2	—	Vrms
VNO	Output noise level	VOL=0dB ATT=0dB Speaten filter:MAX Rg=0,DIN-Audio	—	100	200	μVrms
		VOL=0dB ATT=0dB Speaten filter:OFF Rg=0,DIN-Audio	—	12	24	μVrms
		VOL=- ATT=-28dB Speaten filter : MAX Rg=0,DIN-Audio	—	6.5	13	μVrms
THD	Total harmonic distortion	f=1KHz, Loudness=OFF Vo=0.5Vrms DIN-Audio	—	0.01	0.2	%
CS	Cannel separation	f=1KHz DIN-Audio	—	-80	-70	dB
Tone control						
G(BASS)B	Value of bass boost	f=100Hz	9	12	15	dB
G(BASS)C	Value of bass cut	f=100Hz	-15	-12	-9	dB
G(TRE)B	Value of treble boost	f=10KHz	9	12	15	dB
G(TRE)C	Value of treble boost	f=10KHz	-15	-12	-9	dB
Bass boost						
GBB	Gain of bass boost	f=100Hz	6.5	8.5	10.5	dB

M62496FP

ELECTRONIC VOLUME CONTROL WITH BUILT-IN SPEATEN FILTER

TEST CIRCUIT

(Icc, ATT(VOL), Delta ATT(VOL), G(BASS)B, G(BASS)C, G(TRE)B, G(TRE)C, VOM, VNO, THD, CS)

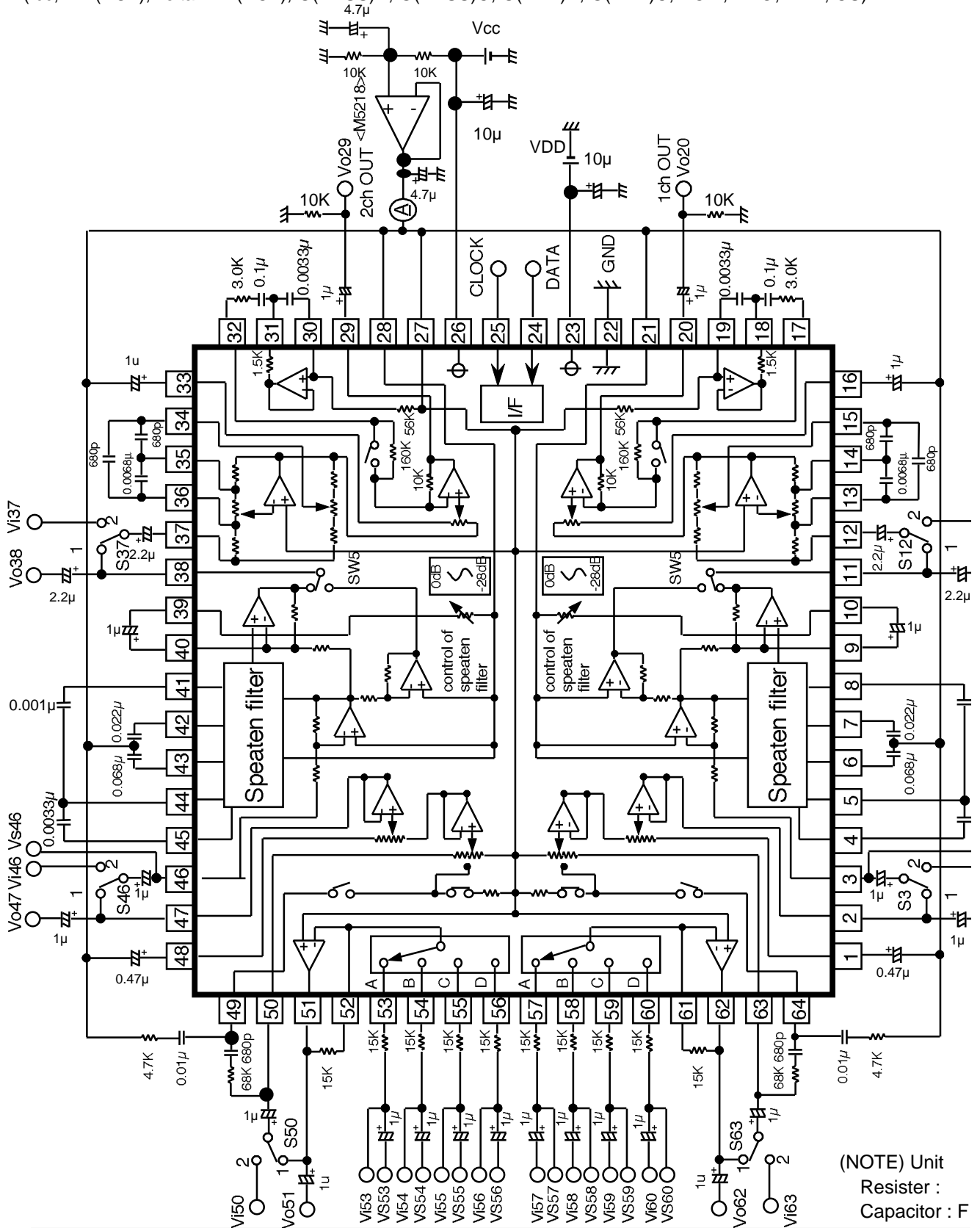

M62496FP

ELECTRONIC VOLUME CONTROL WITH BUILT-IN SPEAKEN FILTER

SWITCH CONDITION

Symbol	Parameter	Switch condition					
		S3	S12	S37	S46	S50	S63
ICC	Circuit current	1	1	1	1	1	1
IREF	REF input current	1	1	1	1	1	1
VOM(SEL)	Maximum output amplitude of selector amp	2	2	2	2	2	2
VNo(SEL)	Output noise level of selector amp.	↓	↓	↓	↓	↓	↓
THD(SEL)	Total harmonic distortion of selector amp.	↓	↓	↓	↓	↓	↓
CS(SEL)	Channel separation of selector amp.	↓	↓	↓	↓	↓	↓
ATT(VOL)	Maximum ATT of the main volume	↓	↓	↓	↓	↓	↓
△ATT(VOL)	△ ATT of the main volume	2	2	2	2	2	2
VIM	Maximum input amplitude	1	1	1	1	1	1
VOM	Maximum output amplitude	↓	↓	↓	↓	↓	↓
VNo	Output noise level	↓	↓	↓	↓	↓	↓
THD	Total harmonic distortion	↓	↓	↓	↓	↓	↓
CS	Channel separation	1	1	1	1	1	1
G(BASS)B	Value of bass boost	2	2	2	2	2	2
G(BASS)C	Value of bass cut	↓	↓	↓	↓	↓	↓
G(TRE)B	Value of treble boost	↓	↓	↓	↓	↓	↓
G(TRE)C	Value of treble boost	↓	↓	↓	↓	↓	↓
GBB	Gain of bass boost	2	2	2	2	2	2

RELATIONSHIPS BETWEEN DATA AND CLOCK

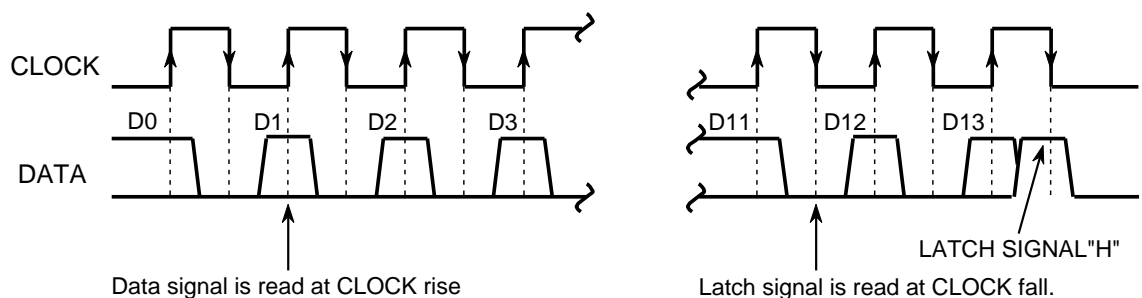

M62496FP

ELECTRONIC VOLUME CONTROL WITH BUILT-IN SPEAKEN FILTER

DIGITAL BLOCK ALTERNATING CURRENT

Symbol	Parameter	Condition		Limits			Unit
				Min	Typ	Max	
V _{IL}	Input voltage (L level)	DATA and CLOCK pins		0	—	0.2 V _{DD}	V
V _{IH}	Input voltage (H level)			0.8 V _{DD}	—	V _{DD}	
I _{IL}	Input current (L level)	V _I =0	DATA and CLOCK pins	-10	—	10	μA
I _{IH}	Input current (H level)	V _I =V _{DD}		—	—	10	

DIGITAL BLOCK DIRECT CURRENT

Symbol	Parameter	Limits			Unit
		Min	Typ	Max	
t _{cf}	CLOCK cycle time	4	—	—	μS
t _{WHC}	CLOCK pulse width (H level)	1.6	—	—	
t _{WLC}	CLOCK pulse width (L level)	1.6	—	—	
t _r	CLOCK rise time	—	—	0.4	
t _f	CLOCK fall time	—	—	0.4	
t _{SD}	DATA setup time	0.8	—	—	
t _{HD}	DATA hold time	0.8	—	—	

CLOCK AND DATA TIMING

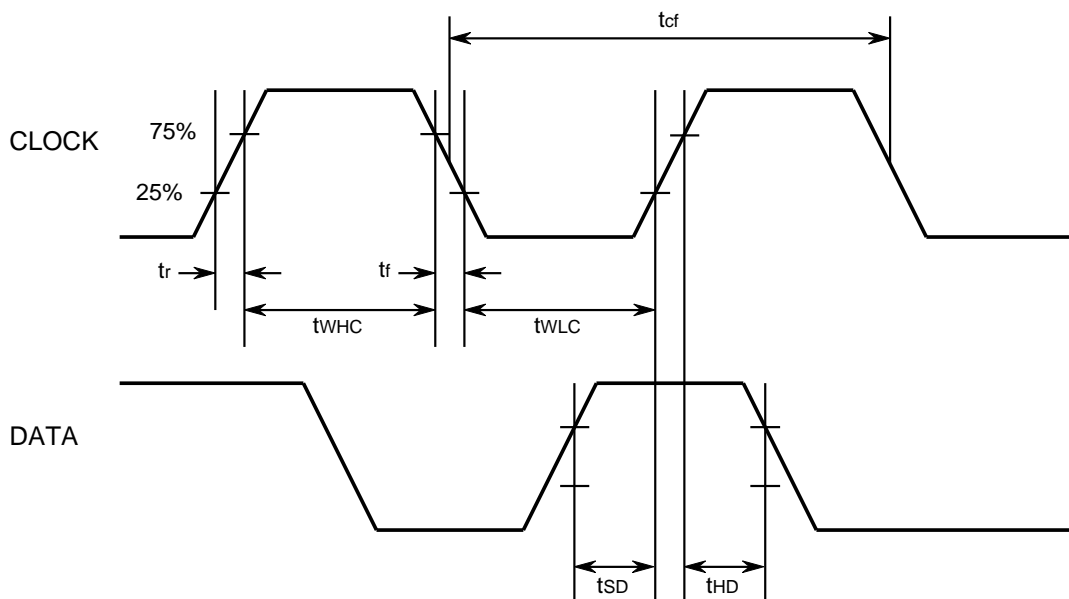

M62496FP

ELECTRONIC VOLUME CONTROL WITH BUILT-IN SPEATEN FILTER

DATA FORMAT

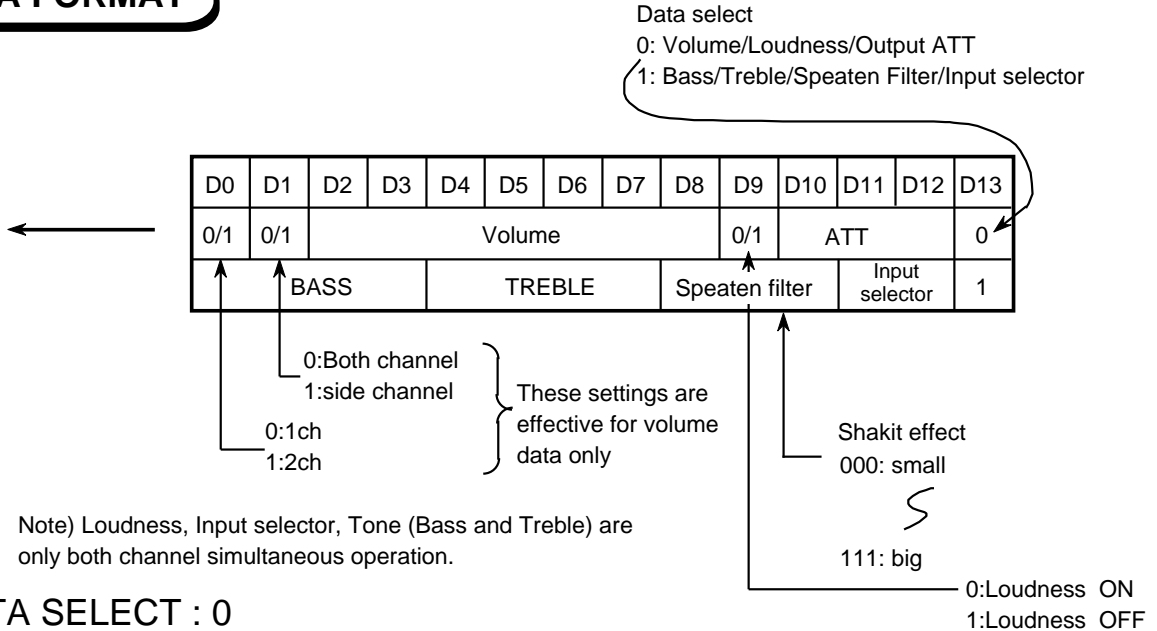

DATA SELECT : 0

VOLUME CODE

ATT1	D2	D3	D4	D5	D6
0dB	H	L	H	L	H
-4dB	L	L	H	L	H
-8dB	H	H	L	L	H
-12dB	L	H	L	L	H
-16dB	H	L	L	L	H
-20dB	L	L	L	L	H
-24dB	H	H	H	H	L
-28dB	L	H	H	H	L
-32dB	H	L	H	H	L
-36dB	L	L	H	H	L
-40dB	H	H	L	H	L
-44dB	L	H	L	H	L
-48dB	H	L	L	H	L
-52dB	L	L	L	H	L
-56dB	H	H	H	L	L
-60dB	L	H	H	L	L
-64dB	H	L	H	L	L
-68dB	L	L	H	L	L
-72dB	H	H	L	L	L
-76dB	L	H	L	L	L
-80dB	H	L	L	L	L
-	L	L	L	L	L

ATT2	D7	D8
0dB	H	H
-1dB	L	H
-2dB	H	L
-3dB	L	L

OUTPUT ATT CODE

OUTPUT ATT	D10	D11	D12
0dB	H	H	H
-4dB	H	H	L
-8dB	H	L	H
-12dB	H	L	L
-16dB	L	H	H
-20dB	L	H	L
-24dB	L	L	H
-28dB	L	L	L

M62496FP

ELECTRONIC VOLUME CONTROL WITH BUILT-IN SPEATEN FILTER

■ DATA SELECT : 1

TONE CODE

BUSS	D0	D1	D2	D3
TREBLE	D4	D5	D6	D7
12dB	H	H	H	H
10dB	L	H	H	H
8dB	H	L	H	H
6dB	L	L	H	H
4dB	H	H	L	H
2dB	L	H	L	H
0dB	H	L	L	H
-2dB	L	L	L	H
-4dB	H	H	H	L
-6dB	L	H	H	L
-8dB	H	L	H	L
-10dB	L	L	H	L
-12dB	H	H	L	L

SPEATEN FILTER EFFECT, X-BASS ON/OFF CODE

EFFECT NFRESISTER	X-BASS ON/OFF	SHAKIT ON/PASS	D8	D9	D10
189	OFF	ON	H	H	H
267	OFF	ON	L	H	H
378	OFF	ON	H	L	H
533	OFF	ON	L	L	H
754	OFF	ON	H	H	L
50K	OFF	ON	L	H	L
50K	OFF	PASS	H	L	L
50K	ON	PASS	L	L	L

INPUT SELECTOR CODE

INPUT SELECTOR	D11	D12
A CH	H	H
B CH	L	H
C CH	H	L
D CH	L	L