

PRELIMINARY
 Notice : This is not a final specification.
 some parametric limits are subject to
 change.

MITSUBISHI SOUND PROCESSORS

M62499FP

SOUND CONTROLLER WITH T-BASS and BBE

Dynamic bass boost/Sound processor with BBE

DESCRIPTION

Home Audio, Radio-Cassette, TV, etc.

FEATURES

<DYNAMIC BASS BOOST FUNCTION>

- It is adaptable to the input level and the maximum boost quantity change.
- It is possible to change five maximum boost quantity modes.
 <+20dB,+15dB,+10dB,+5dB,flat>

<HIGH DEFINITION SOUND FUNCTION>

- Build-in BBE Sound (Low level=fixation/High level=3 steps can be changed.)

<INPUT SELECTOR>

- 5ch stereo input change.

<TONE CONTROL>

- BASS/TREBLE(±10dB,8dB,6dB,4dB,2dB,flat;2dB/Step)

<GAIN CONTROL>

- The passage profit variability (0dB~+14dB:2dB step)

<FUNCTION MODE SELECTOR FUNCTION>

- Monaural (L,R,L+R),Vocal cut

<ELECTRONIC VOLUME FUNCTION>

- 0dB~ -87dB, - ;1dB/step

<EXTENSION PORT OUTPUT FUNCTION>

- Eight output ports(Six pieces of NPN open collector output,Two pieces of three state output)

PACKAGE

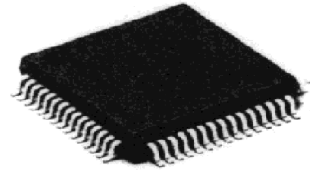

64pinQFP
(Pitch:0.8mm)

*BBE is the registration brand of the BBE Sound company.

As for this IC, only the brand of BBE and the person who was permitted to use a patent can do sale and supply.

RECOMMENDED OPERATING CONDITIONS

Supply voltage range •••• Analog VCC=3.5V(typ),VEE=-3.5V(typ)
 Digital VDD=5.0V(typ)

SYSTEM CONFIGURATION

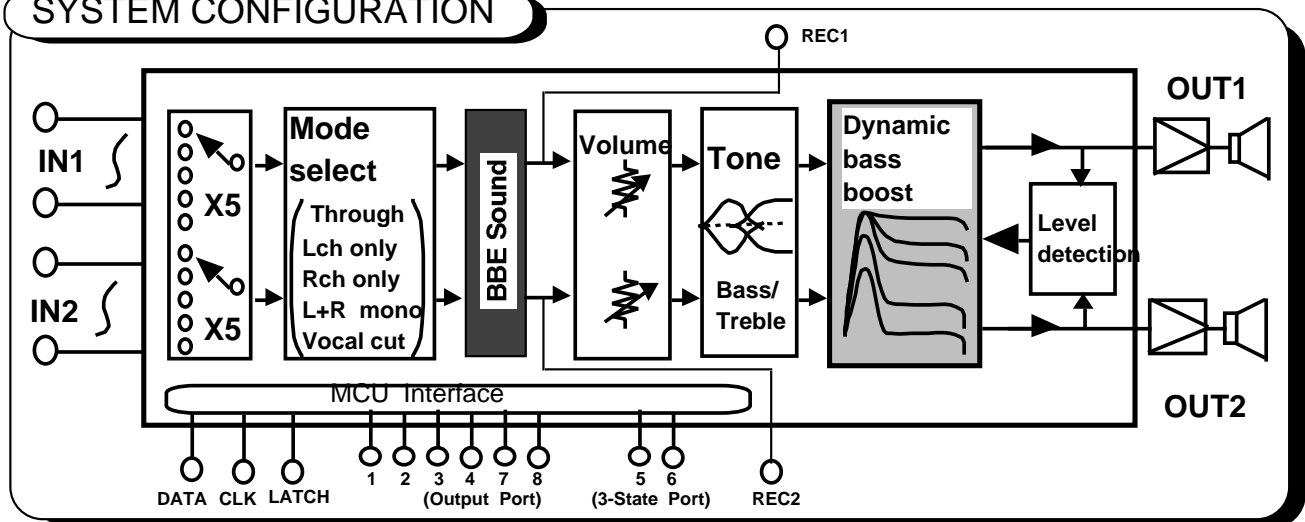

PRELIMINARY
 Notice : This is not a final specification.
 some parametric limits are subject to
 change.

MITSUBISHI SOUND PROCESSORS

M62499FP

SOUND CONTROLLER WITH T-BASS and BBE

PIN CONFIGURATION AND INTERNAL BLOCK DIAGRAM

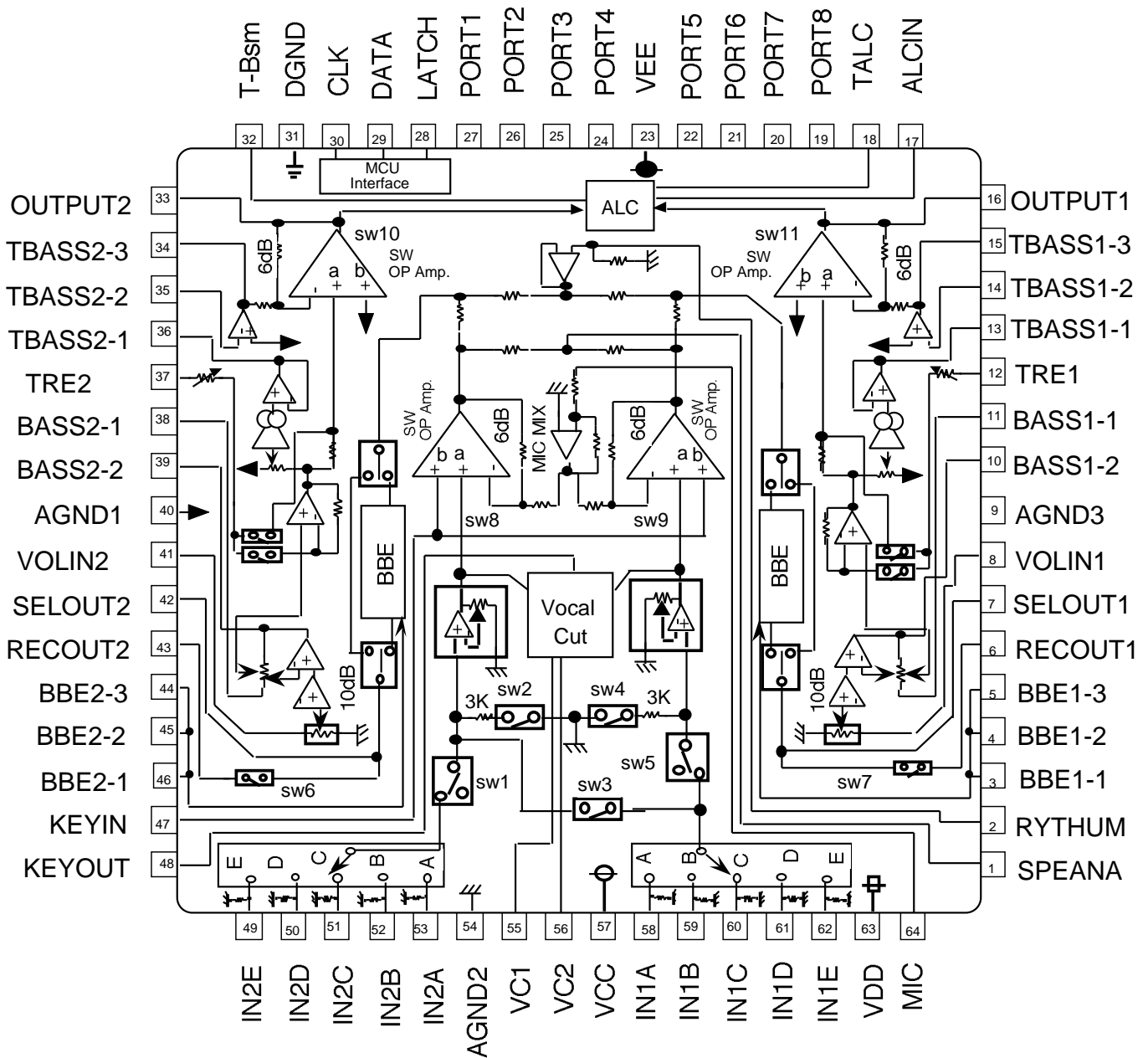

PRELIMINARY
 Notice : This is not a final specification.
 some parametric limits are subject to
 change.

MITSUBISHI SOUND PROCESSORS

M6249FP

SOUND CONTROLLER WITH T-BASS and BBE

APPLICATION

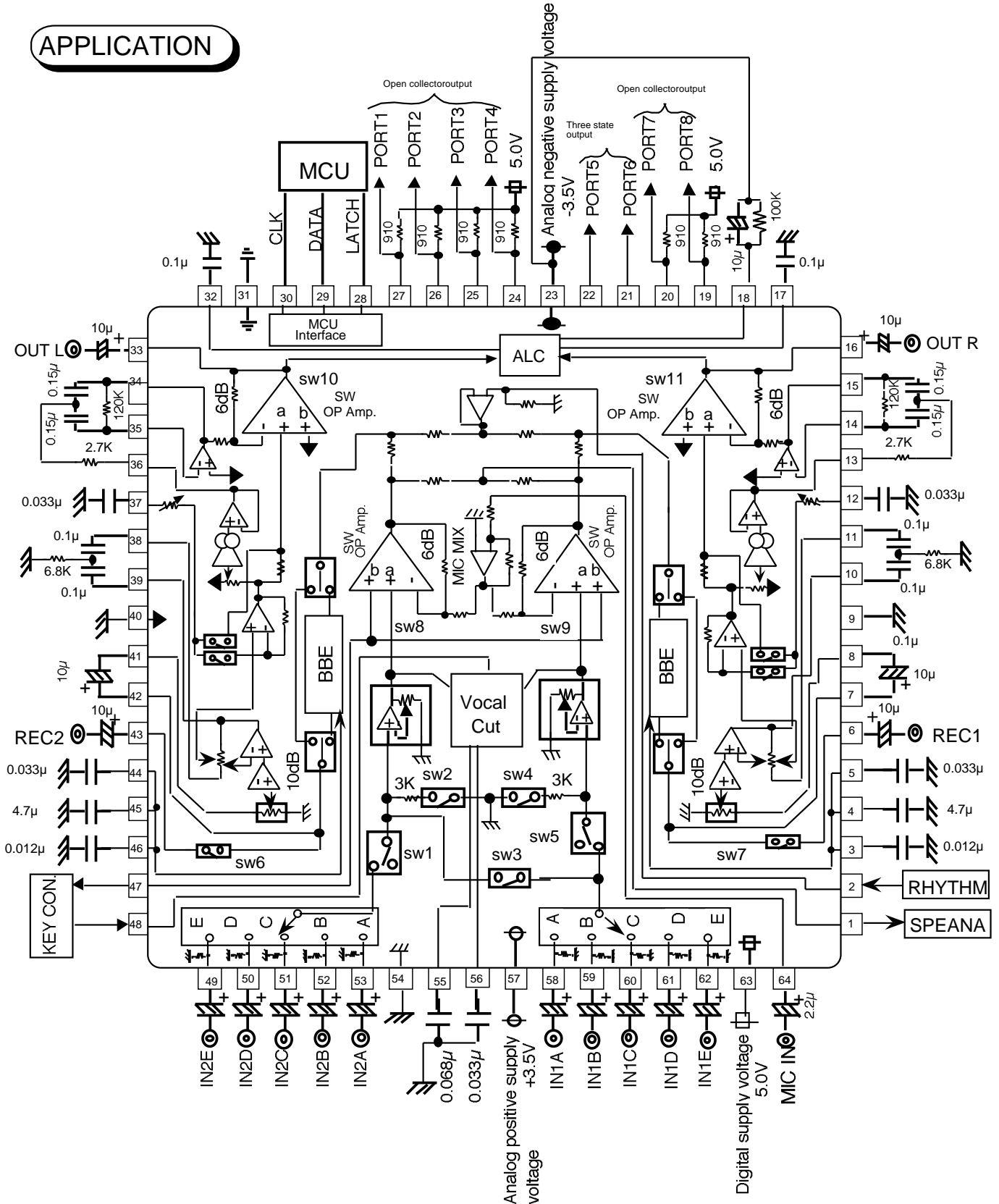

PRELIMINARY
 Notice : This is not a final specification.
 some parametric limits are subject to
 change.

MITSUBISHI SOUND PROCESSORS

M6249FP

SOUND CONTROLLER WITH T-BASS and BBE

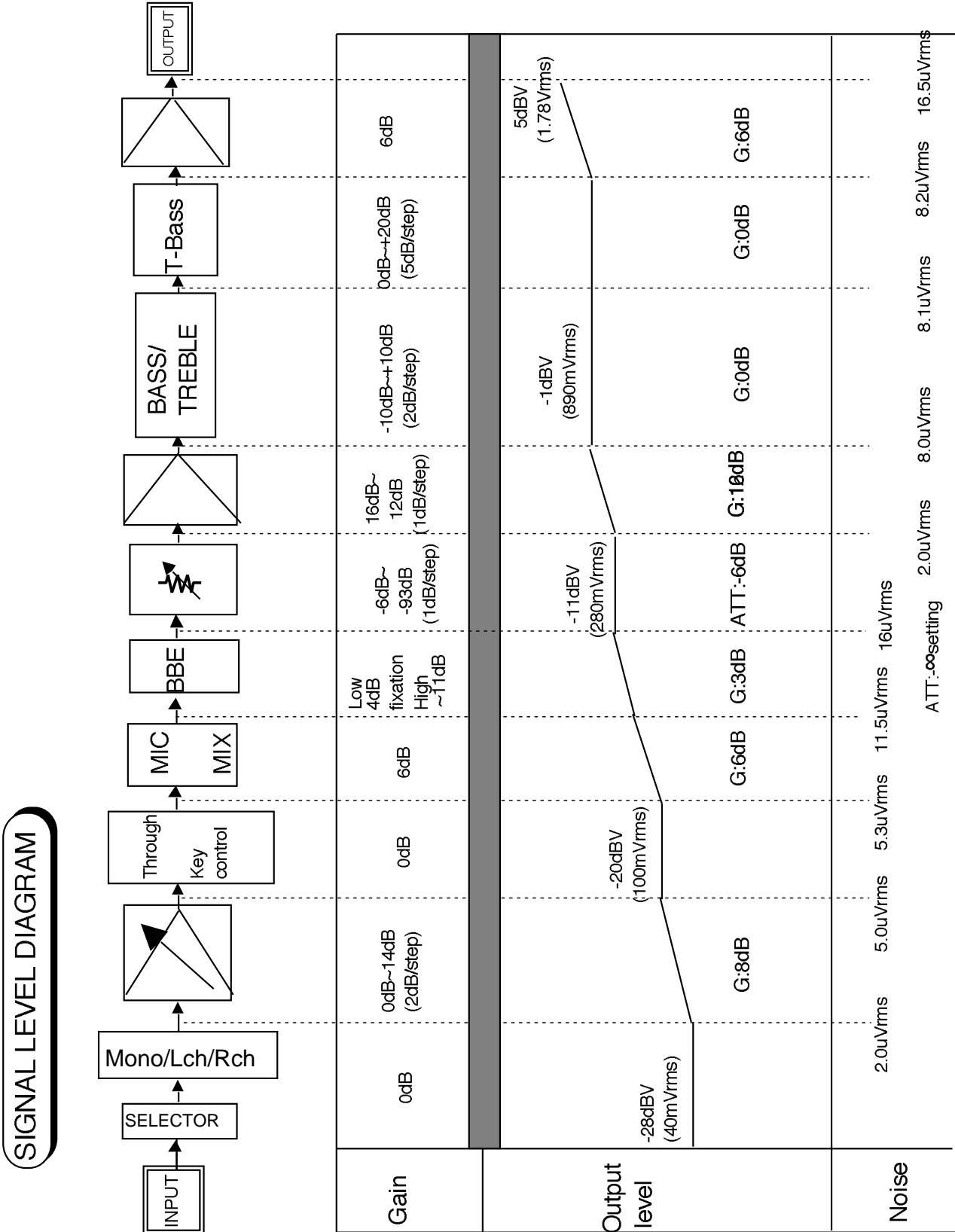

PRELIMINARY
 Notice ; This is not a final specification.
 some parametric limits are subject to
 change.

MITSUBISHI SOUND PROCESSORS

M62499FP

SOUND CONTROLLER WITH T-BASS and BBE

ABSOLUTE MAXIMUM RATINGS

Symbol	Parameter	Conditions	Limits	Units
VCC	Analog positive supply voltage		+4.0	V
VEE	Analog nagative supply voltage		-4.0	
VDD	Digital supply voltage		6.0	V
Pd	Power dissipation	Ta 25°C	1000	mW
K	Thermal derating	Ta>25°C, (Note1)PC Board	10	mW/°C
Topr	Operating temperature		-20~+65	°C
Tstg	Storage temperature		-40~+125	°C

THERMAL DERATING

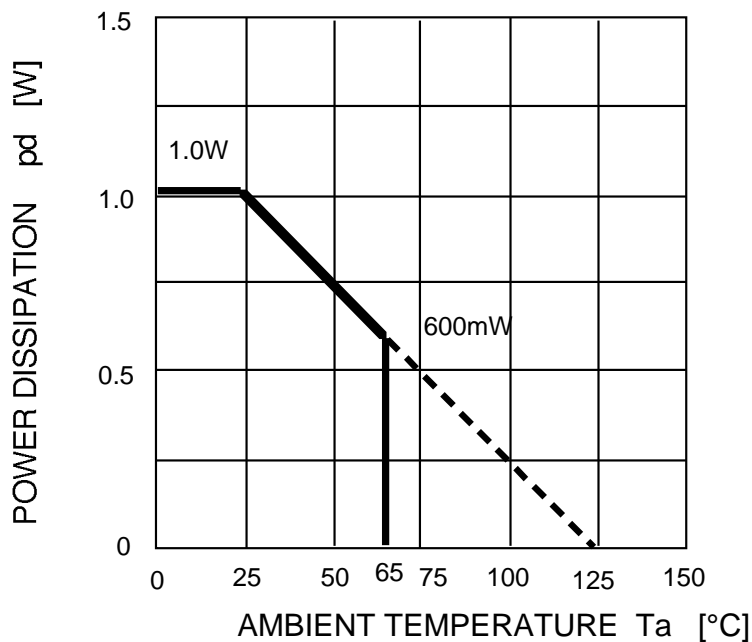

(Note1)PC Board

PC Board Size
 70mmx70mm
 PC Board Thickness
 1.6mm
 PC Board Material
 Epoxy
 Copper Film Thickness
 18μm
 Copper Foil Size
 0.25mmx25mm

PRELIMINARY
 Notice : This is not a final specification.
 some parametric limits are subject to
 change.

MITSUBISHI SOUND PROCESSORS

M62499FP

SOUND CONTROLLER WITH T-BASS and BBE

RECOMMENDED OPERATING CONDITION

(Ta=25°C, unless otherwise noted.)

Parameter	Symbol	Conditions	Limits			Units
			MIN	TYP	MAX	
Analog positive supply voltage	VCC		3.25	3.5	3.75	V
Analog negative supply voltage	VEE		-3.75	-3.5	-3.25	
Digital supply voltage	VDD	VDD VCC	4.75	5.0	5.25	V
Logic"H"level input voltage	VIH		VDD-1	—	VDD	V
Logic"L"level input voltage	VIL		0	—	0.8	V

RELATIONSHIP BETWEEN DATA AND CLOCK

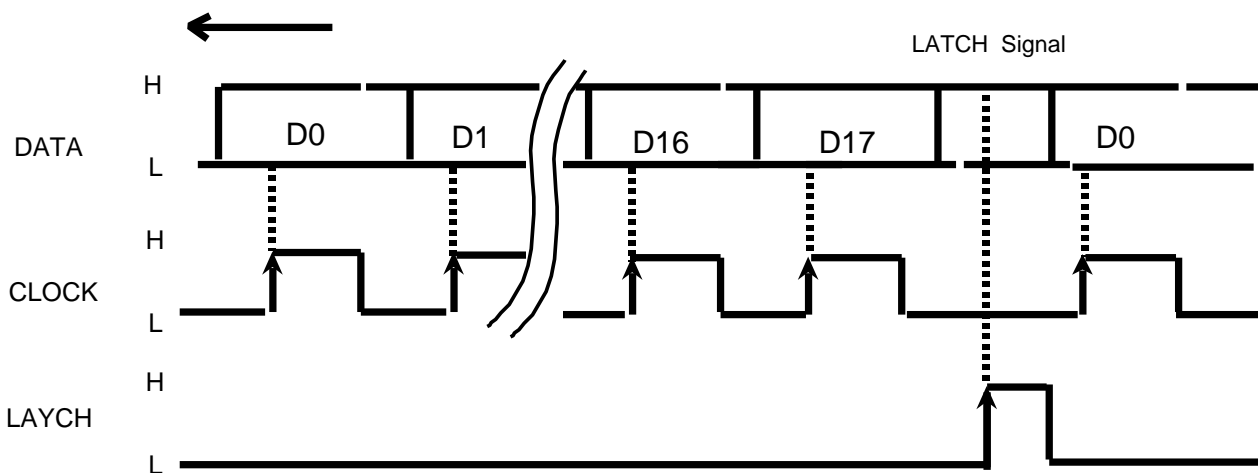

Data signal is read at the rising edge of clock, and Signal is latched at the rising edge of the latch signal.

(DATA and CLOCK are "H" setting, it doesn't accept LATCH.)

PRELIMINARY
 Notice : This is not a final specification.
 some parametric limits are subject to
 change.

MITSUBISHI SOUND PROCESSORS

M62499FP

SOUND CONTROLLER WITH T-BASS and BBE

CLOCK AND DATA TIMING

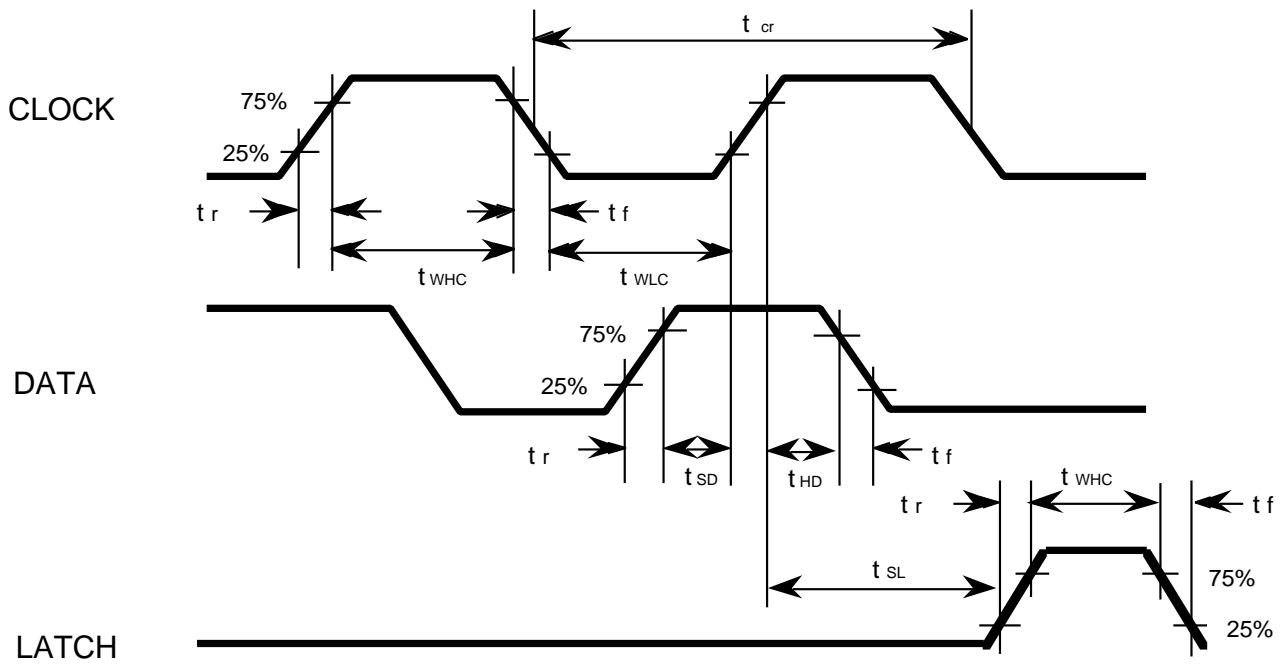

DIGITAL BLOCK TIMING REGULATION

Symbol	Parameter	Limits			Units
		Min	typ	Max	
t_{cr}	CLOCK cycle time	4	-	-	μsec
t_{WHC}	CLOCK pulse width ("H"level)	1.6	-	-	
t_{WLC}	CLOCK pulse width ("L"level)	1.6	-	-	
t_r	CLOCK,DATA,LATCH rise time	-	-	0.4	
t_f	CLOCK,DATA,LATCH fall time	-	-	0.4	
t_{SD}	DATA setup time	0.8	-	-	
t_{HD}	DATA hold time	0.8	-	-	
t_{SL}	LATCH setup time	1	-	-	
t_{WHL}	LATCH pulse width	1.6	-	-	

PRELIMINARY
 Notice : This is not a final specification.
 some parametric limits are subject to
 change.

MITSUBISHI SOUND PROCESSORS

M62499FP

SOUND CONTROLLER WITH T-BASS and BBE

INPUT DATA FORMAT

Fore kinds of input format options are available by address fixation bit of D15,D16 and D17.
 (When the IC powered up, the internal settings are not fixed.)

Fixation bit
 (For address)

MSB		← Input direction															LSB		
		DO	D1	D2	D3	D4	D5	D6	D7	D8	D9	D10	D11	D12	D13	D14	D15	D16	D17
(1)	Input selector	Gain control			Bass boost/Cut				Treble boost/Cut				0	0	0	0			
	I0	I1	I2	G0	G1	G2	B0	B1	B2	B3	T0	T1					T2	T3	
(2)	Port output 1-4	Try state output 5,6			Port output 7,8		KARAOKE control				0	1	0	0					
	O0	O1	O2	O3	Ss0	Ss1	St0	St1	O8	O9					K0	K1	K2	K3	
(3)	Lch volume control						1	Rch volume control						0	1	1			
	L0	L1	L2	L3	L4	L5		L6	R0	R1	R2	R3	R4				R5	R6	
(4)	VOL Amp. gain(L)			VOL Amp. gain(R)			1	BBE		1	T-Bass gain			1	Rec mute	1	1	1	
	VL0	VL1	VL2	VR0	VR1	VR2		BE0	BE1		TB0	TB1	TB2		M0				

(Note.) In data transmission setting of slot 4, put interval of 100msec.

(1)-1 SETTING CODE OF INPUT SELECTOR

Selector	I0	I1	I2	Selector SW	SW 1,5	SW MUTE
Input mute	0	0	0	All off	off	on
A	0	0	1	A	on	off
B	0	1	0	B		
C	0	1	1	C		
D	1	0	0	D		
E	1	0	1	E		
Prohibition	1	1	0	Unsettled	Unsettled	Unsettled
Prohibition	1	1	1	Unsettled	Unsettled	Unsettled

(1)-2 SETTING CODE OF GAIN CONTROL

Gain	G0	G1	G2
0 dB	0	0	0
2 dB	0	0	1
4 dB	0	1	0
6 dB	0	1	1
8 dB	1	0	0
10 dB	1	0	1
12 dB	1	1	0
14 dB	1	1	1

(2)-3 SETTING CODE OF KARAOKE CONTROL

	K0	K1	K2	K3	sw1	sw2	sw3	sw4	sw5	sw8,9
STEREO	1	1	0	0	on	off	off	off	on	a
MONO(L+R)	1	1	1	1	on	off	on	on	off	b
L MPX	1	0	1	1	on	off	off	on	off	b
R MPX	0	1	1	1	off	off	on	on	off	b
Vocal cut (L-R)	1	1	0	1	on	off	off	off	on	b

(4)-4 SETTING CODE OF REC MUTE

Rec output	M0
Rec Mute OFF	0
Rec Mute ON	1

Note) Do not input other data than the above.

(There is not an operation guarantee except the specification data code.)

PRELIMINARY
 Notice : This is not a final specification.
 some parametric limits are subject to
 change.

MITSUBISHI SOUND PROCESSORS

M62499FP

SOUND CONTROLLER WITH T-BASS and BBE

(2)-1 (Port output mode)
 Open collector output

DATA	O0	O1	O2	O3	O6	O7
Pin	Port 1	Port 2	Port 3	Port 4	Port 7	Port 8
0	Electric current suction OFF					
1	Electric current suction ON					

(2)-2 (Try state port output mode)

Ss0	Ss1	Port5	St0	St1	Port6
0	0	Low	0	0	Low
1	0	open	1	0	open
0	1	open	0	1	open
1	1	Hi	1	1	Hi

(4)-2 BBE CONTROL

BBE setting	BE0	BE1
Bypass(BBE-->OFF)	0	0
BBE1 (High:+3dB)	0	1
BBE2 (High:+7dB)	1	0
BBE3 (High:+11dB)	1	1

(4)-3 SETTING CODE OF DYNAMIC BASS
 BOOST

Gain	TB0	TB1	TB2	sw9,10
Output Mute	0	0	0	b
T-Bass OFF	1	0	0	a
5dB	0	1	0	
10dB	1	1	0	
15dB	0	0	1	
20dB	1	0	1	
Prohibition	0	1	1	
Prohibition	1	1	1	↓

PRELIMINARY
 Notice : This is not a final specification.
 some parametric limits are subject to
 change.

MITSUBISHI SOUND PROCESSORS

M62499FP

SOUND CONTROLLER WITH T-BASS and BBE

(3)-1 SETTING CODE OF MASTER VOLUME ATTENUATION

ATT	Lch	L0	L1	L2	L3	L4
	Rch	R0	R1	R2	R3	R4
-0dB		0	0	0	0	0
-2dB		1	0	0	0	0
-4dB		0	1	0	0	0
-6dB		1	1	0	0	0
-8dB		0	0	1	0	0
-10dB		1	0	1	0	0
-12dB		0	1	1	0	0
-14dB		1	1	1	0	0
-16dB		0	0	0	1	0
-18dB		1	0	0	1	0
-20dB		0	1	0	1	0
-22dB		1	1	0	1	0
-24dB		0	0	1	1	0
-26dB		1	0	1	1	0
-28dB		0	1	1	1	0
-30dB		1	1	1	1	0
-32dB		0	0	0	0	1
-34dB		1	0	0	0	1
-36dB		0	1	0	0	1
-40dB		1	1	0	0	1
-44dB		0	0	1	0	1
-48dB		1	0	1	0	1
-52dB		0	1	1	0	1
-56dB		1	1	1	0	1
-60dB		0	0	0	1	1
-64dB		1	0	0	1	1
-68dB		0	1	0	1	1
-72dB		1	1	0	1	1
-76dB		0	0	1	1	1
-80dB		1	0	1	1	1
-84dB		0	1	1	1	1
-		1	1	1	1	1

ATT	L5	L6
	R5	R6
-0dB	0	0
-1dB	1	0
-2dB	0	1
-3dB	1	1

The combination of L5,L6(R5,R6) works when setting equal to or less than -36dB. At equal to or more than -34dB, only L5,R5 are effective.

Note)The volume ATT quantity is a goal value.

By the equal to or less than -70dB setting,it sometimes shifts little.

(4)-1 SETTING CODE OF VOL AMP. GAIN SWITCHING

VOL Amp. gain	VL0	VL1	VL2
	VR0	VR1	VR2
16dB	0	0	0
15dB	0	0	1
14dB	0	1	0
13dB	0	1	1
12dB	1	0	0
11dB	1	0	1
10dB	1	1	0
9dB	1	1	1

PRELIMINARY
 Notice ; This is not a final specification.
 some parametric limits are subject to
 change.

MITSUBISHI SOUND PROCESSORS

M62499FP

SOUND CONTROLLER WITH T-BASS and BBE

(1)-3 Tone control setting code

BASS				GAIN	TREBLE			
B0	B1	B2	B3		T0	T1	T2	T3
1	0	1	1	+10dB	1	0	1	1
0	0	1	1	+8dB	0	0	1	1
1	1	0	1	+6dB	1	1	0	1
0	1	0	1	+4dB	0	1	0	1
1	0	0	1	+2dB	1	0	0	1
0	0	0	1	0dB	0	0	0	1
0	0	0	0	0dB	0	0	0	0
1	0	0	0	-2dB	1	0	0	0
0	1	0	0	-4dB	0	1	0	0
1	1	0	0	-6dB	1	1	0	0
0	0	1	0	-8dB	0	0	1	0
1	0	1	0	-10dB	1	0	1	0

(Note) Above-mentioned Gain is setting code name. Depending on the fixed number of putting outside, fixed gain doesn't sometimes output.

PRELIMINARY
 Notice : This is not a final specification.
 some parametric limits are subject to
 change.

MITSUBISHI SOUND PROCESSORS

M62499FP

SOUND CONTROLLER WITH T-BASS and BBE

MASTER VOLUME CIRCUIT

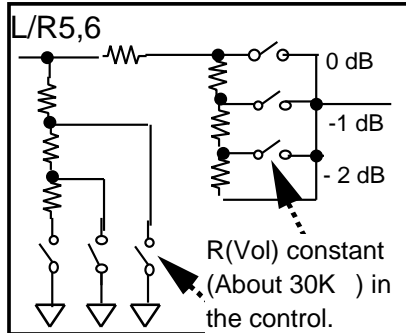
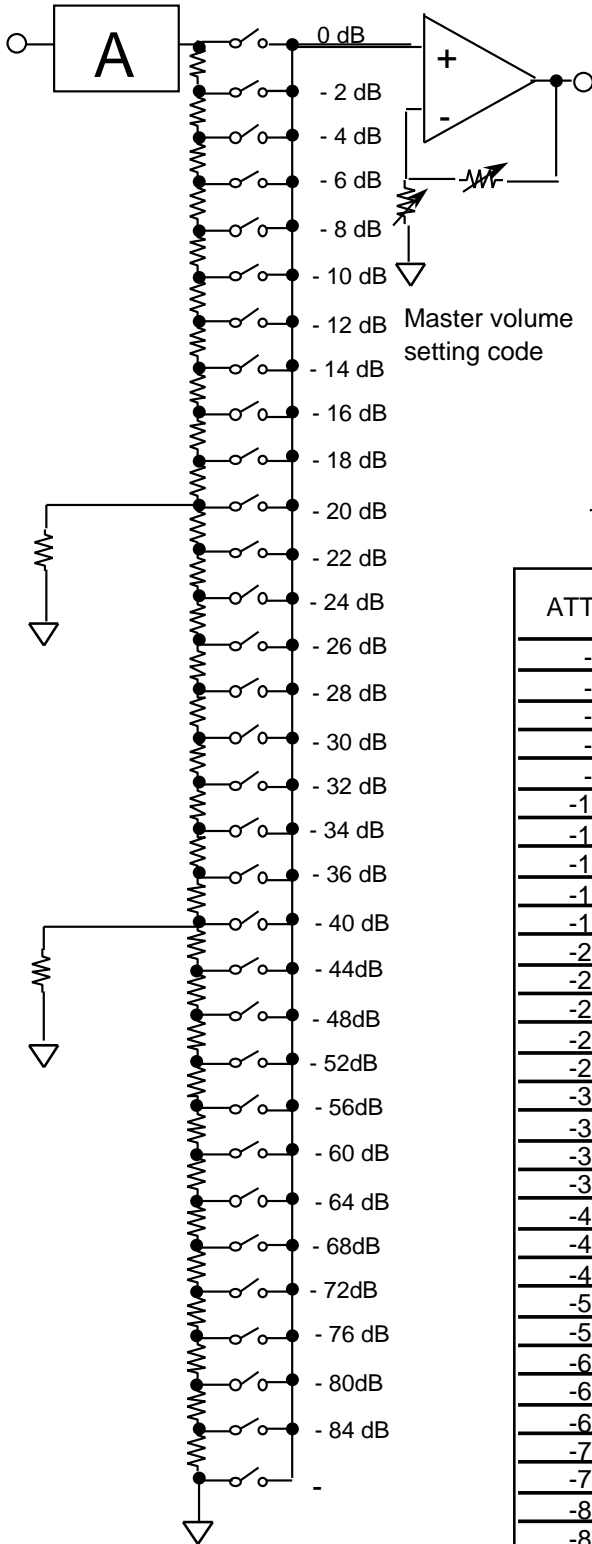

A part:3dB ATT

L/R5	L/R6	ATT
0	0	-0.0dB
1	0	-1.0dB
0	1	-2.0dB
1	1	-3.0dB

VOL Amp. gain	VI 0	VI 1	VI 2
	VR0	VR1	VR2
16dB	0	0	0
15dB	0	0	1
14dB	0	1	0
13dB	0	1	1
12dB	1	0	0
11dB	1	0	1
10dB	1	1	0
9dB	1	1	1

ATT	Lch	L0	L1	L2	L3	L4
	Rch	R0	R1	R2	R3	R4
-0db	0	0	0	0	0	0
-2dB	1	0	0	0	0	0
-4dB	0	1	0	0	0	0
-6dB	1	1	0	0	0	0
-8dB	0	0	1	0	0	0
-10dB	1	0	1	0	0	0
-12dB	0	1	1	0	0	0
-14dB	1	1	1	0	0	0
-16dB	0	0	0	1	0	0
-18dB	1	0	0	1	0	0
-20dB	0	1	0	1	0	0
-22dB	1	1	0	1	0	0
-24dB	0	0	1	1	0	0
-26dB	1	0	1	1	0	0
-28dB	0	1	1	1	0	0
-30dB	1	1	1	1	0	0
-32dB	0	0	0	0	1	0
-34dB	1	0	0	0	0	1
-36dB	0	1	0	0	0	1
-40dB	1	1	0	0	0	1
-44dB	0	0	1	0	0	1
-48dB	1	0	1	0	0	1
-52dB	0	1	1	0	0	1
-56dB	1	1	1	0	0	1
-60dB	0	0	0	1	0	1
-64dB	1	0	0	1	0	1
-68dB	0	1	0	1	0	1
-72dB	1	1	0	1	0	1
-76dB	0	0	1	1	0	1
-80dB	1	0	1	1	0	1
-84dB	0	1	1	1	0	1
-	1	1	1	1	1	1

PRELIMINARY
 Notice : This is not a final specification.
 some parametric limits are subject to
 change.

MITSUBISHI SOUND PROCESSORS

M62499FP

SOUND CONTROLLER WITH T-BASS and BBE

FUNCTION DESCRIPTION

(1) TONE CONTROLLER (BASS) EQUIVALENT CIRCUIT

1-1. Bass Equivalent circuit (Boost setting)

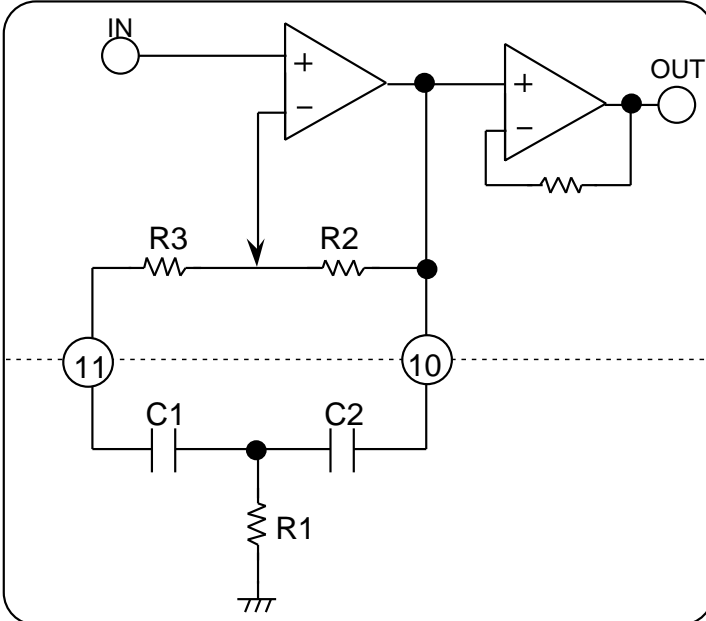

Resonance Frequency f_0

$$f_0 = \frac{1}{2 \sqrt{R1 \cdot (R2+R3) \cdot C1 \cdot C2}} \text{ [Hz]}$$

Resonance park Q

$$Q = \frac{1}{C1+C2} \sqrt{\frac{C1 \cdot C2 \cdot R2}{R1}}$$

Boost quantity G_v

Then $C1=C2$

$$G_v = 20 \log \left(\frac{\frac{R2+R3}{R1} + 2}{\frac{R3}{R1} + 2} \right) \text{ [dB]}$$

1-2. Bass Equivalent circuit (Cut setting)

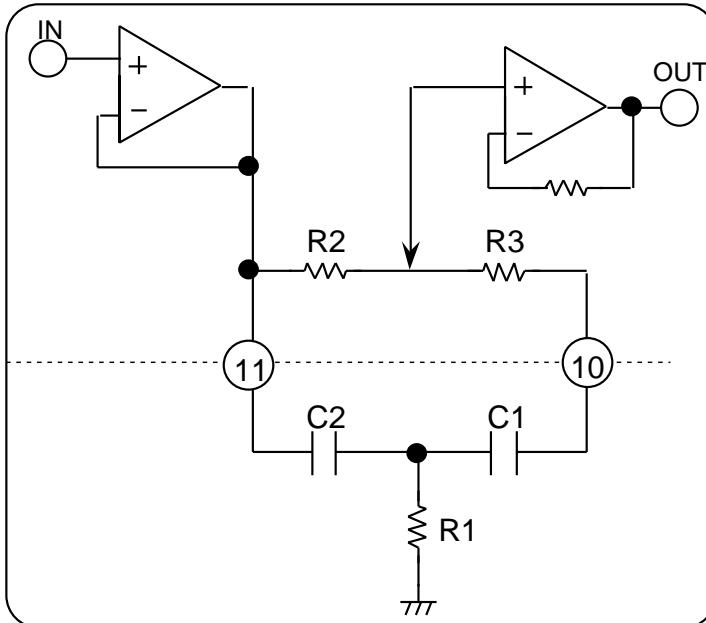

Resonance Frequency f_0

$$f_0 = \frac{1}{2 \sqrt{R1 \cdot (R2+R3) \cdot C1 \cdot C2}} \text{ [Hz]}$$

Resonance park Q

$$Q = \frac{1}{C1+C2} \sqrt{\frac{C1 \cdot C2 \cdot R2}{R1}}$$

Boost quantity G_v

Then $C1=C2$

$$G_v = 20 \log \left(\frac{\frac{R3}{R1} + 2}{\frac{R2+R3}{R1} + 2} \right) \text{ [dB]}$$

(Ex.) Bass band setting [f=100Hz]

$R1=6.8K$, $C1=C2=0.068\mu F$

PRELIMINARY
 Notice : This is not a final specification.
 some parametric limits are subject to
 change.

MITSUBISHI SOUND PROCESSORS

M62499FP

SOUND CONTROLLER WITH T-BASS and BBE

BLOCK FUNCTION OF DYNAMIC BASS BOOST PART

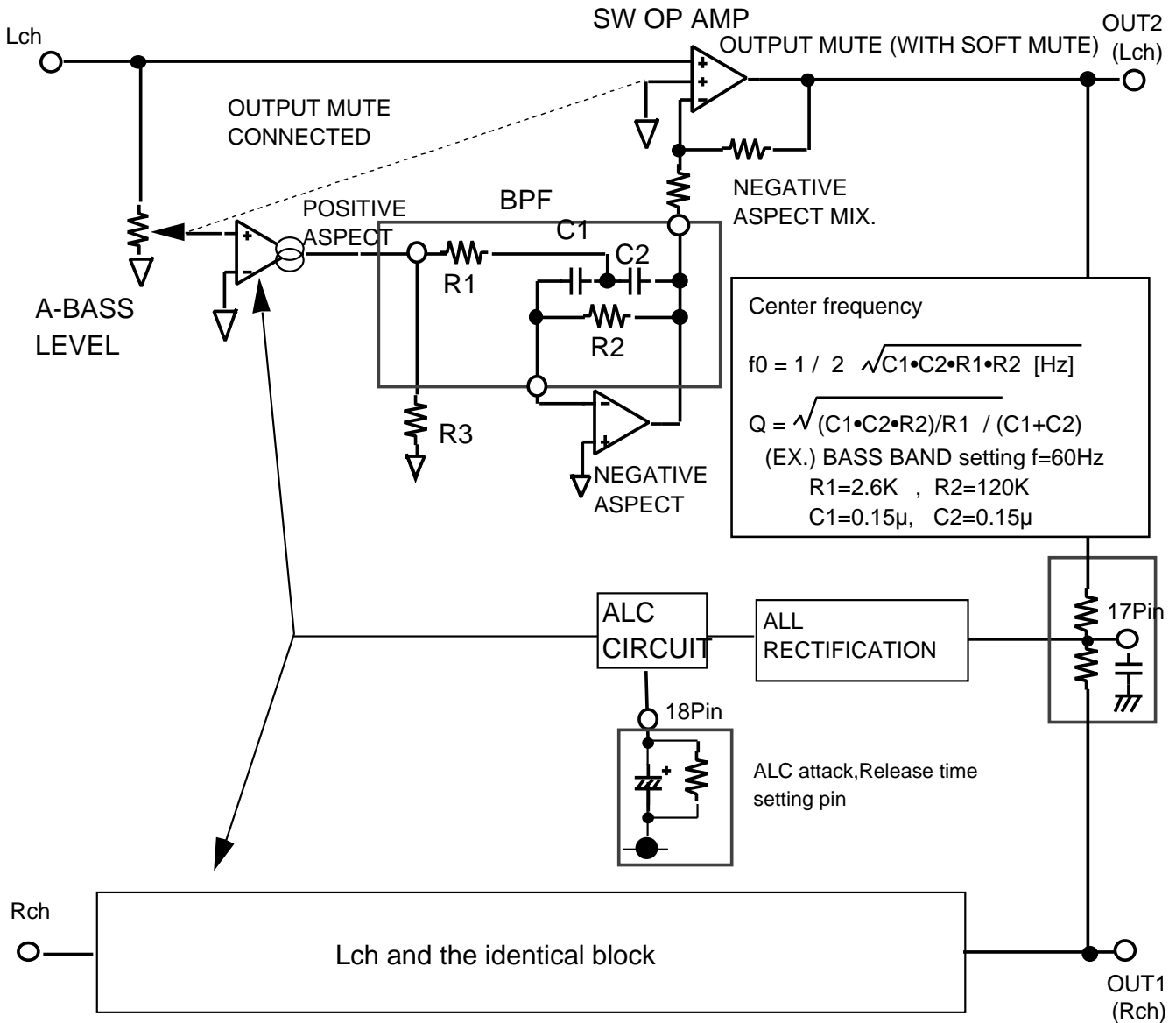

<SOFT MUTE CIRCUIT EXPLANATION>

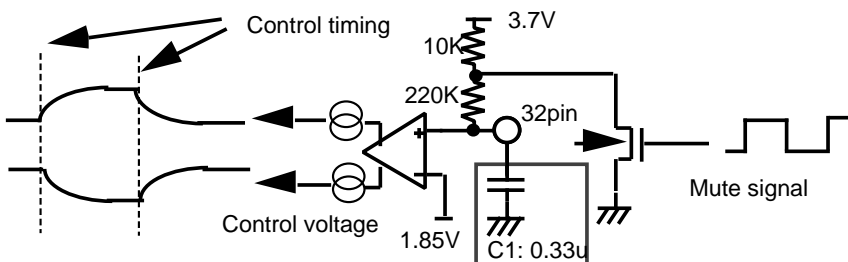

The fixed number is fixed in putting condenser C1 out of 32Pin at shock prevention operation, It became about 0.1sec at 0.33uF setting,

PRELIMINARY
 Notice : This is not a final specification.
 some parametric limits are subject to
 change.

MITSUBISHI SOUND PROCESSORS

M62499FP

SOUND CONTROLLER WITH T-BASS and BBE

OUTPUT PORT CIRCUIT

1) Output port circuit

19,20,24,25,26,27Pin $I_o=10\text{mA}$, $V_c=0.2\text{V}(\text{typ})$

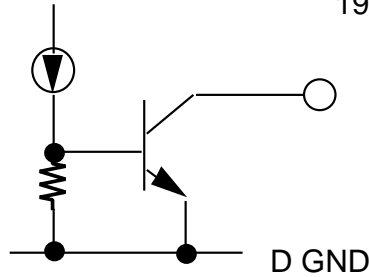

With output pin voltage being the inside of the range of D GND~9V and using.

2) Output port:Try state

21,22Pin

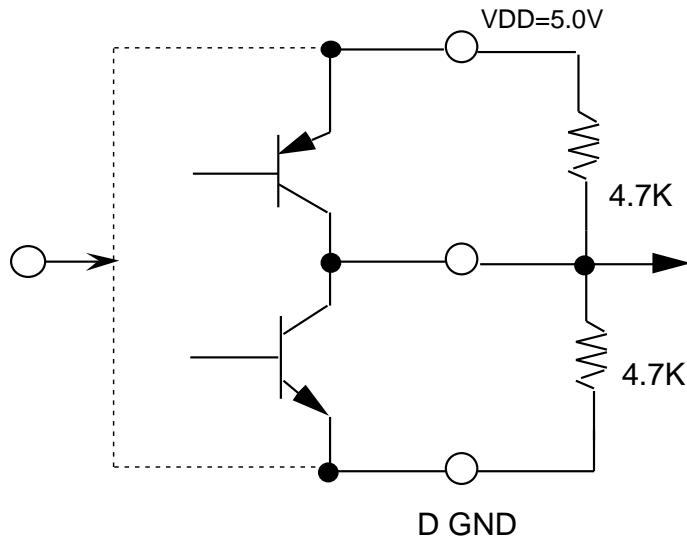

	3 value output example
Hi	4.80V
Mid	2.50V
Low	0.25V

With output pin voltage being the inside of the range of D GND~D VDD and using.

PRELIMINARY
Notice ; This is not a final specification.
some parametric limits are subject to
change.

MITSUBISHI SOUND PROCESSORS

M62499FP

SOUND CONTROLLER WITH T-BASS and BBE

BBE BLOCK

This system brings a replay sound close to the field sound boundlessly.

Low boost (f=20HZ)=+3dB fixation

High boost (f=10KHZ)=+11dB/+7dB/+3dB possible variably

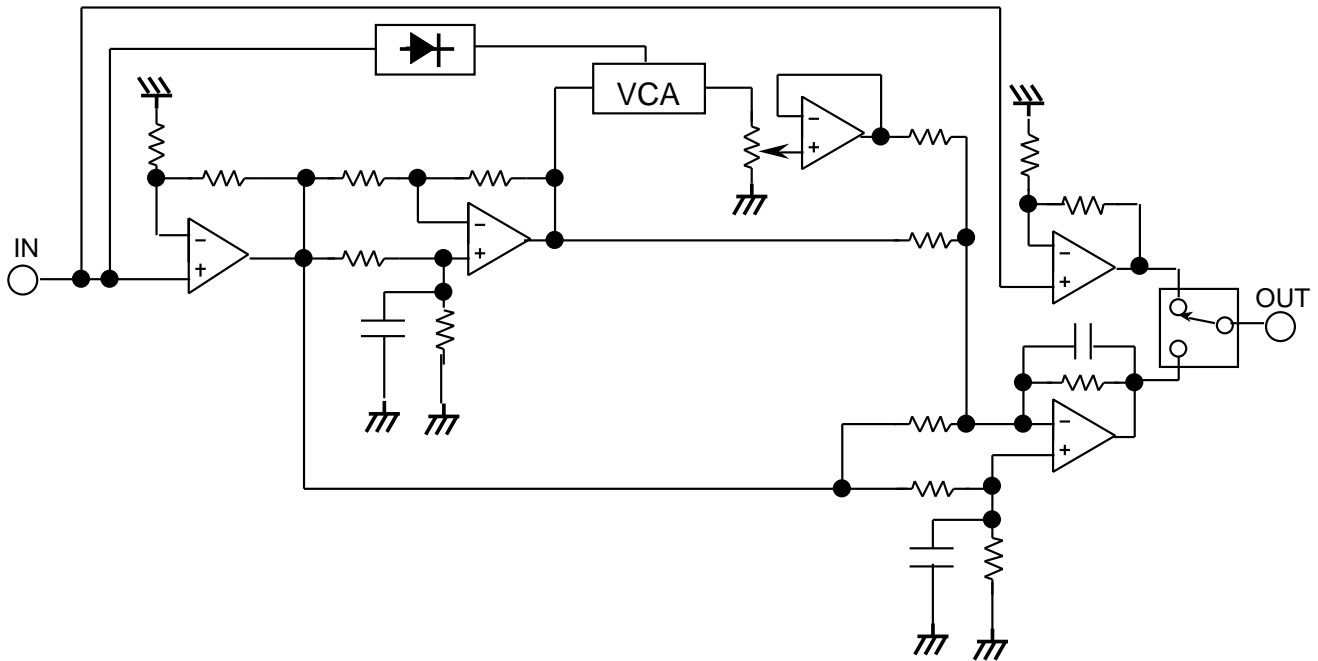

PRELIMINARY
 Notice : This is not a final specification.
 some parametric limits are subject to
 change.

MITSUBISHI SOUND PROCESSORS

M62499FP

SOUND CONTROLLER WITH T-BASS and BBE

ELECTRICAL CHARACTERISTICS

(Ta=25°C, VCC=+3.5V, VEE=-3.5V, VDD=5.0V, f=1kHz, unless otherwise noted.

GAIN Cont.=8dB, VOL=0dB, TONE Cont.=0dB(Flat), T-Bass=0dB(OFF), BBE=0dB(OFF))

(1) Power supply characteristics

Parameter	Symbol	Test condition	Limits			Units
			Min	Typ	Max	
Circuit current of analog positive supply voltage	ICC	No signal setting.	—	35		mA
Circuit current of negative positive supply voltage	IEE	No signal setting.		-35	—	mA
Circuit current of digital supply voltage	IDD	No signal setting.	—			mA

(2) Input/Output characteristics

	Parameter	Symbol	Test condition	Limits			Units
				Min	Typ	Max	
General characteristics	Input resistance	Rin		—	51	—	K
	Cross talk between selector	ST	Vi=0.04Vrms, RL=10K, JIS-A Rg=10K, 1pin=GND	—	-80	-60	dB
	Input mute attenuation	MTATTIN	Vi=0.04Vrms, JIS-A, 1Pin=GND (Input Selector-->Mute)	—	-90	-80	dB
	Maximum output voltage	VOM	RL =10K, THD=1%	2.0	2.4	—	Vrms
	Pass gain	Gv	Vi=0.04Vrms, FLAT	27	30	33	dB
	Distortion factor	THD	BW=400~30kHz Vo=1.0Vrms, RL=10K	—	0.02	0.05	%
		THD(REC)	BW=400~30kHz Vo=0.16Vrms, RL=10K	—	0.01	0.05	
	Output noise voltage (Remaining noise voltage)	Vno1	Rg=0, JIS-A, VOL=0dB, Gain Cont.=0dB	—	60	100	μVrms
		Vno2	Rg=0, JIS-A, VOL= - dB, Gain Cont.=0dB	—	12	24	
		VNO(REC)	Rg=0, JIS-A, Gain Cont.=0dB	—	10	20	
Crosstalk between channels	CT	Vo=0.04Vrms, RL=10K, JIS-A Rg=10K, 1pin=GND	—	-70	-60	dB	
Volume	Volume step resolution ability	VOLSTEP		—	1	—	dB
	Profit deviation between volume	DVOL	Gv deviation of volume part	-1.5	0	1.5	

PRELIMINARY
 Notice : This is not a final specification.
 some parametric limits are subject to
 change.

MITSUBISHI SOUND PROCESSORS

M62499FP

SOUND CONTROLLER WITH T-BASS and BBE

Parameter		Symbol	Test condition	Limits			Units
				Min	Typ	Max	
Gain control	GAIN CONTROL MAXIMUM PROFIT OF GAIN	GCMAX	Vo=0.04Vrms , RL=10K ,JIS-A Rg=10K ,Gain:14dB~0dB	12	14	16	dB
	GAIN CONTROL RESOLUTION ABILITY	GCSTEP		—	2	—	
	BALANCE BETWEEN CHANNEL	BALT	Logic control reference	-1.5	0	+1.5	
Tone control	TONE CONTROL VOLTAGE GAIN	T -10dB	Vo=0.04Vrms Treble (f=10KHz) Bass (f=150Hz)	-13	-10	-7	dB
		T +10dB		-13	-10	-7	
	TONE CONTROL RESOLUTION ABILITY	TCSTEP	Logic control reference	—	2	—	
	BALANCE BETWEEN CHANNEL	BALT		-1.5	0	+1.5	
T-Bass control	T-BASS VOLTAGE GAIN MAX. LANGE	TBB20dB	f=60Hz,Vi=0.01Vrms	15	20	25	dB
	T-BASS RESOLUTION ABILITY	TBSTEP		Logic control reference	—	5	
	BALANCE BETWEEN CHANNEL	BALT		-2.0	0	+2.0	
BBE	BYPASS GAIN	BBE-BP	f=20to20KHz,Vi=0.02Vrms	—	0	—	dB
	LOW BOOST (f=20Hz)	BBE-Lo	f=20Hz,Vi=0.02Vrms	—	3	—	
	HIGH BOOST (f=10kHz)	BBE-Hi	f=10KHz,Vi=0.02Vrms	—	11	—	

(4) PORT OUTPUT (VDD=5.0V setting)

Parameter	Symbol	Test condition	Limits			Units
			Min	Typ	Max	
PORT OUTPUT REMAINDER VOLTAGE 19,20,24,25,26,27Pin (Open collector output)	VpOC	RL=450 (10mA)	—	0.2	0.6	V
THREE STATE HIGH OUTPUT	VpTH	R(GND):4.7K R(Vdd):5.6K	4.5	4.8	—	
THREE STATE LOW OUTPUT	VpTL	R(GND):4.7K R(Vdd):5.6K	—	0.2	0.5	