

M62520FP

PRELIMINARY

HIGH PRECISION LOW INPUT/OUTPUT DIFFERENTIAL 3.3V FIXED OUTPUT VOLTAGE REGULATOR WITH RESET

DESCRIPTION

M62520FP is monolithic integrated circuit integrating high precision regulator and reset IC targeted for printer, CD-ROM, CD-R, and the other OA equipments. This regulator features high precision output, low input/output differential, high current capability, and high ripple rejection ratio. Compact application design is made easy by small 8pin package.

FEATURES

- *High precision output voltage-----3.3V±2%
- *High output current-----300mA(max.)
- *High ripple rejection ratio-----80dB(typ.)
- *Low input/output differential--- 0.3V(typ.)(IL=150mA)
- *Small limiting current due to shorted loads by drooping fold-back protection----- 20mA(typ.)
- *Load regulation-----30mV(typ.)
- *ON/OFF control available for regulator output
- *Non-adjustment for reset detection voltage----3.9V±2%
- *Reset--monitors input voltage 5V

Some parametric limits are subject to change.

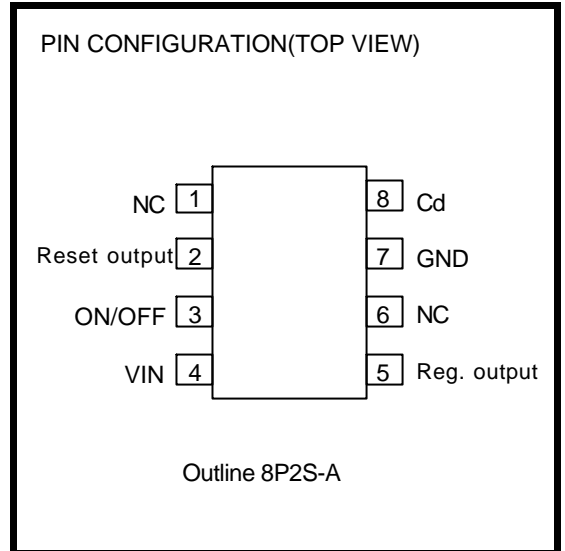

APPLICATION

OA equipments such as printer, CD-ROM, and so forth

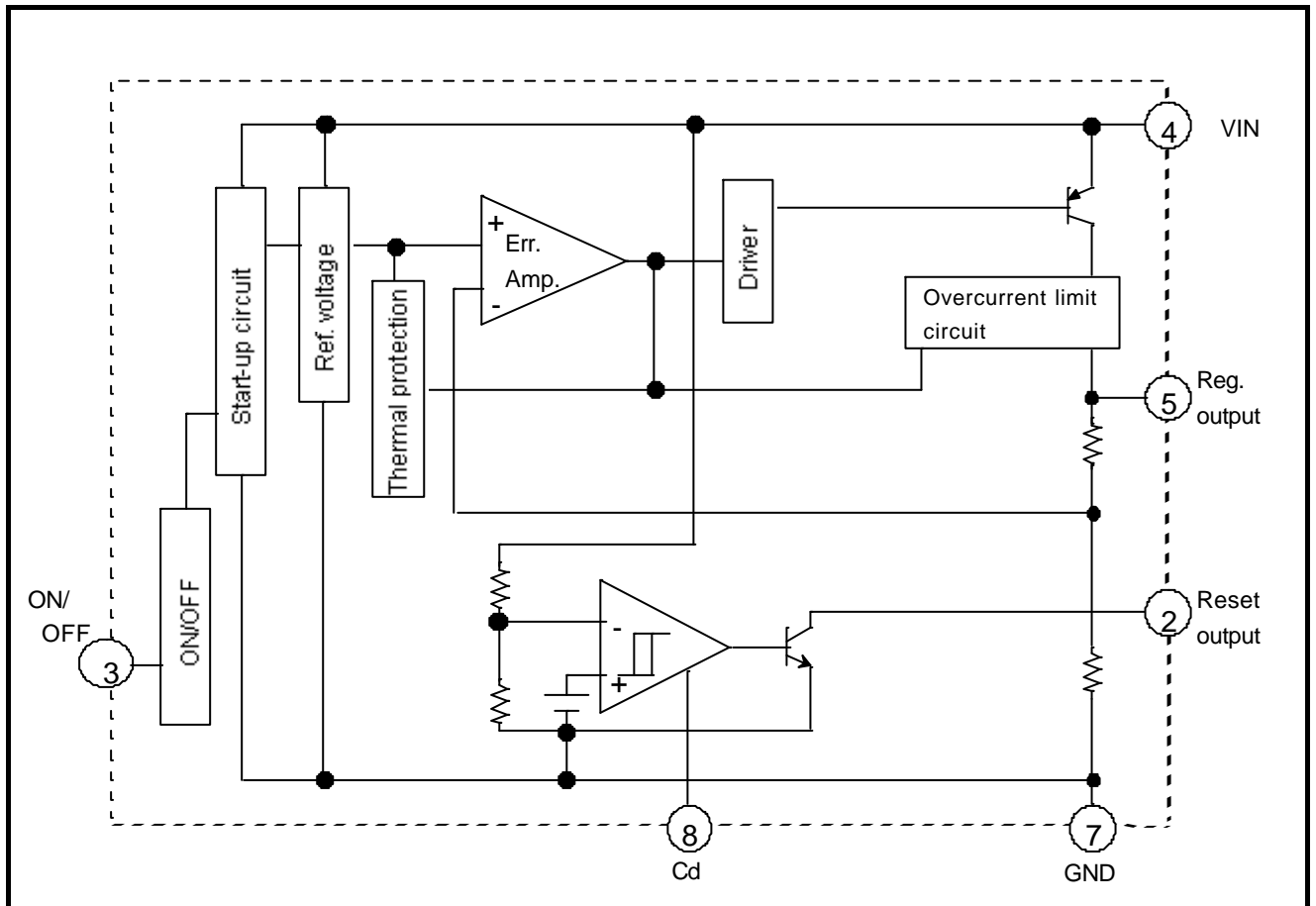

PRELIMINARY

M62520FP

HIGH PRECISION LOW INPUT/OUTPUT DIFFERENTIAL 3.3V FIXED OUTPUT VOLTAGE REGULATOR WITH RESET

ABSOLUTE MAXIMUM RATINGS(Ta=25°C, unless otherwise noted.)

Symbol	Parameter	Condition	Ratings	Unit
V _{IN}	Input voltage		-0.3~9	V
I _L	Load current *1		300	mA
P _d	Power dissipation		530	mW
K _θ	Thermal derating ratio	Ta>25°C	4.24	mW/°C
T _{opr}	Operating temperature		-20~+75	°C
T _{stg}	Storage temperature		-40~+150	°C

ELECTRICAL CHARACTERISTICS(Ta=25°C, V_{IN}=5V, C_I=10μF, C_O=47μF, unless otherwise need.)

BLOCK	Symbol	Parameter	Test conditions	Limits			Unit
				Min.	Typ.	Max.	
All device	V _{IN}	Supply voltage range		V _{OUT} +0.3		8	V
	I _{CC1}	Circuit current 1	I _L =0mA		1.2		mA
	I _{CC2}	Circuit current at OFF	V _{ON} /OFF=0V		350		μA
Regulator	V _{OUT}	Output voltage	I _L =30mA	3.234	3.3	3.366	V
	V _{IO}	Input/output differential	I _L =150mA		0.3		V
	Reg-IN	Input regulation	V _{IN} =4.4V~5.5V, I _L =30mA		10		mV
	Reg-L	Load regulation	I _L =0mA~250mA		30		mV
	V _{NO}	Output noise voltage	BW=10Hz~100KHz		40	120	μVrms
	RR	Ripple rejection ratio	vin=0dBm, f=120Hz, I _L =30mA	60	80		dB
	I _{OS}	Output short holding current			20		mA
	TC _{VO}	Output voltage temp.coefficient	Ta=-20~75°C, I _L =30mA		0.2		mV/°C
Reset	V _S	Detection voltage		3.822	3.9	3.978	V
	ΔV _S	Hysteresis voltage		100	150	200	mV
	t _{pd}	Delay time	C _d =0μF		30	90	μs
			C _d =0.1μF	5	10	20	ms
	V _{SAT}	Output saturation voltage	V _{IN} =3.5V, I _{sink} =1mA		0.2	0.4	V
	V _{OPL}	Threshold operating voltage	L reset type minimum supply voltage for IC operation	RL=2.2kΩ V _{SAT} ≤0.4V		0.7	0.8
RL=100kΩ V _{SAT} ≤0.4V					0.6	0.7	
ON/OFF control	V _{ON}	ON threshold voltage		1.6		V _{IN} +0.3	V
	V _{OFF}	OFF threshold voltage		-0.3		0.4	V

PRELIMINARY

M62520FP

HIGH PRECISION LOW INPUT/OUTPUT DIFFERENTIAL 3.3V FIXED
OUTPUT VOLTAGE REGULATOR WITH RESET

TIMING CHART

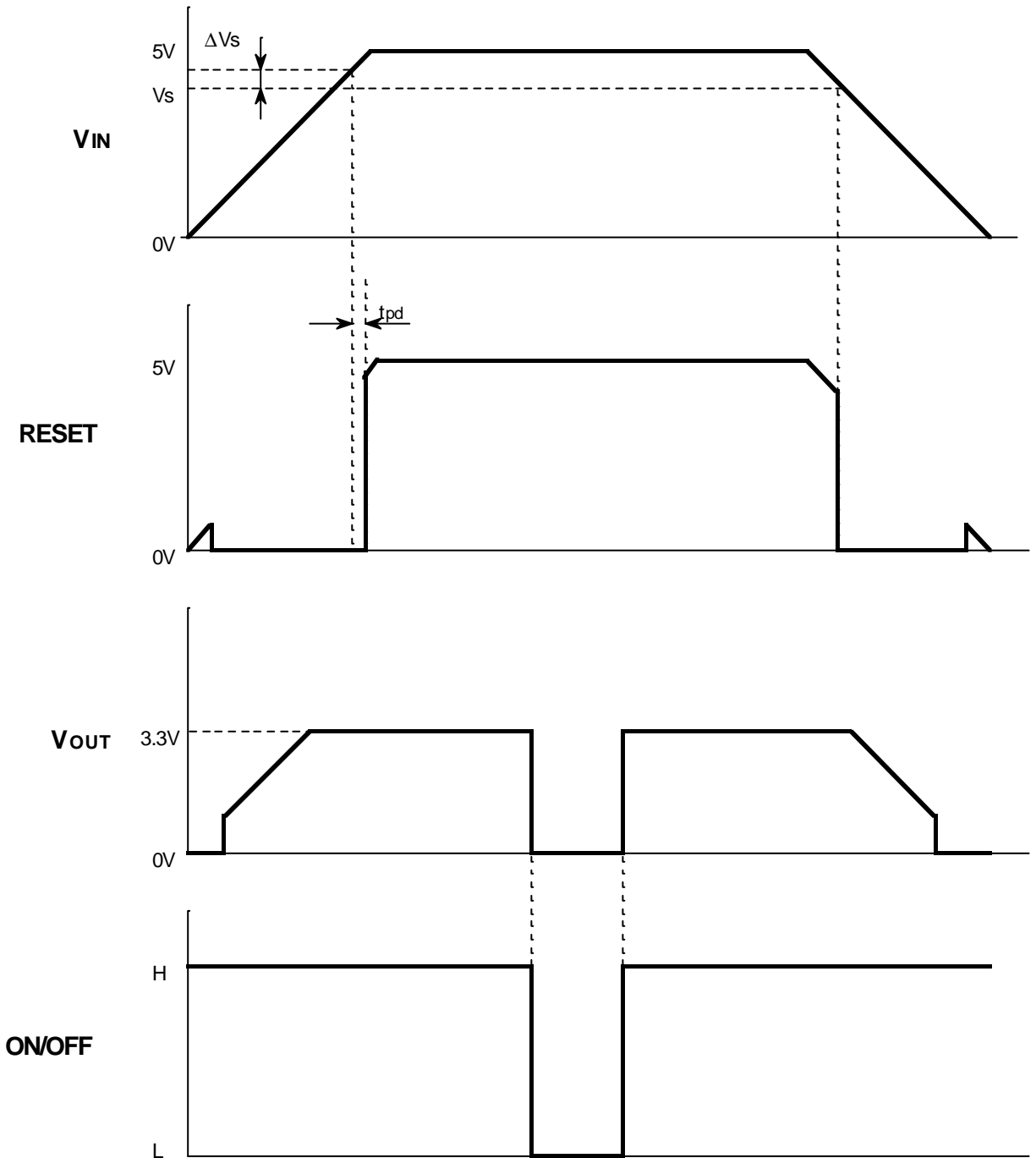

PRELIMINARY

M62520FP

HIGH PRECISION LOW INPUT/OUTPUT DIFFERENTIAL 3.3V FIXED
OUTPUT VOLTAGE REGULATOR WITH RESET

STANDARD CONNECTIONS

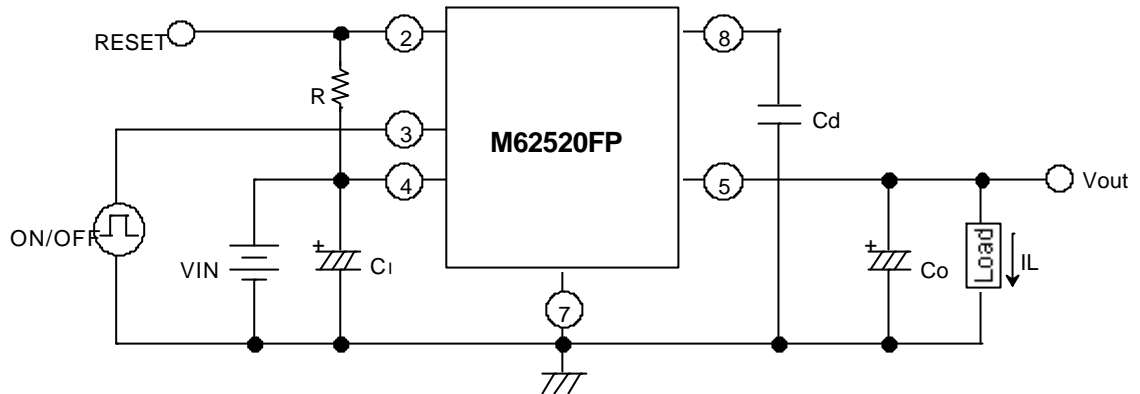

Note1. R is a pull-up resistance for reset terminal. 2.2kohm is recommended for the value.

Note2. C1 works for stabilizing input voltage. Recommended value is 10uF.

Note3. Co works for preventing the output voltage from oscillation. Minimum value is 10uF.
Recommended value is 47uF.

Note4. Delay time for reset is changeable by the capacitance connected to Cd terminal.

Even when no capacitor is connected, 30usec.(typ.) delay time is available.

Below shows how to set the delay time.

$$\text{Delay time: } T_{pd}(\text{ms}) = 100 \times C_d(\mu\text{F})$$

Example: when 0.1uF is connected to Cd terminal.

$$\begin{aligned} T_{pd}(\text{ms}) &= 100 \times 0.1(\mu\text{F}) \\ &= 10(\text{ms}) \end{aligned}$$

Note5. Connect ON/OFF terminal and VIN when ON/OFF function is not needed.

Note6. Get the capacitors close to IC terminals in case the operation is not stabilized by the wiring resistance between each capacitor and IC terminals.