



M63160J

STEPPING MOTOR DRIVER

REJ03F0038-0110Z

Rev.1.1

May.21.2004

Description

This semiconductor integrated circuit includes for H bridge circuit for stepper Motor drive. Output transistor is DMOS. Motor power supply; is possible to drive until 52V maximum.

Function Outline

1. Maximum output current : Peak 2.0A
2. Low output 's Ron.: 1.1Ω
3. Includes two stepping motor driver circuit
 - * Two DC Motor and One Stepping Motor possible to drive.
4. Motor control by serial interface.(Frequency=20MHz maximum)
5. Includes 5V- switching regulator.
6. Includes thermal shut down circuit

PIN CONFIGURATION

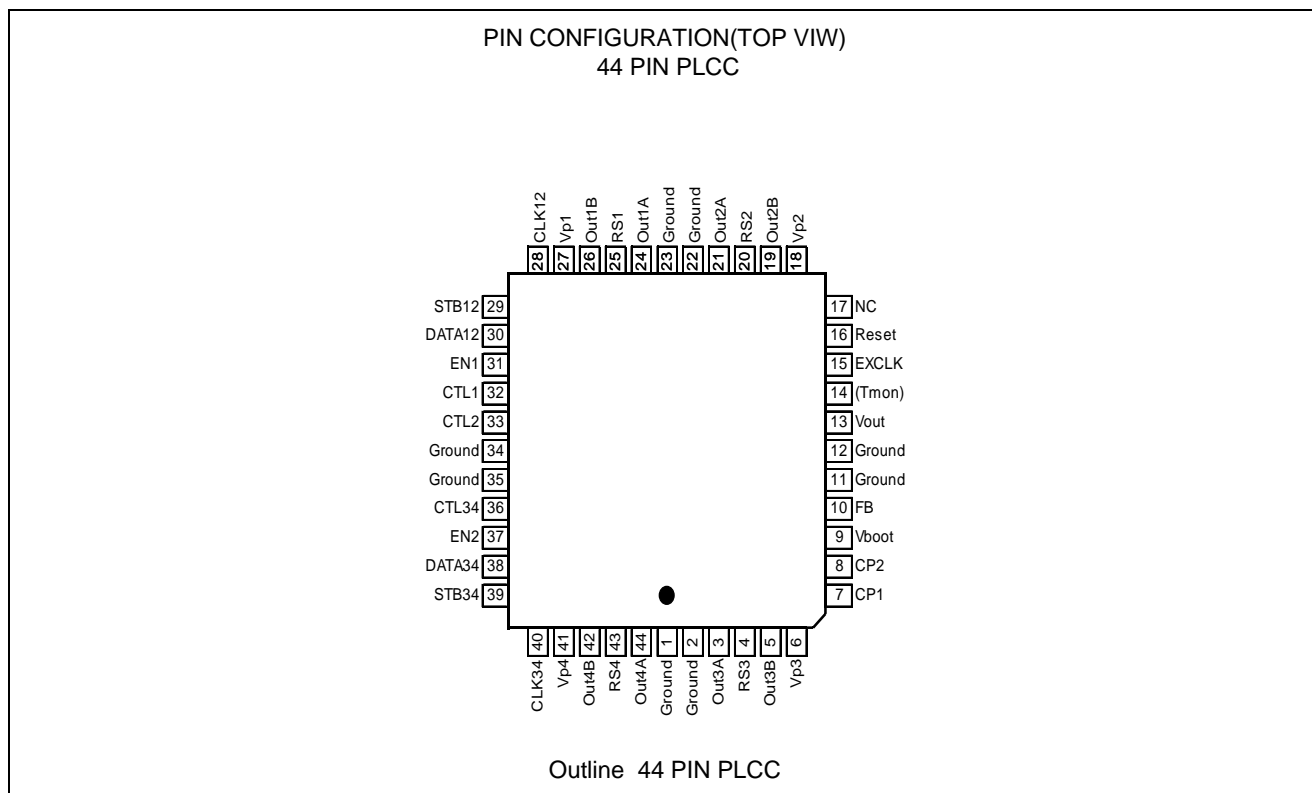

Block Diagram

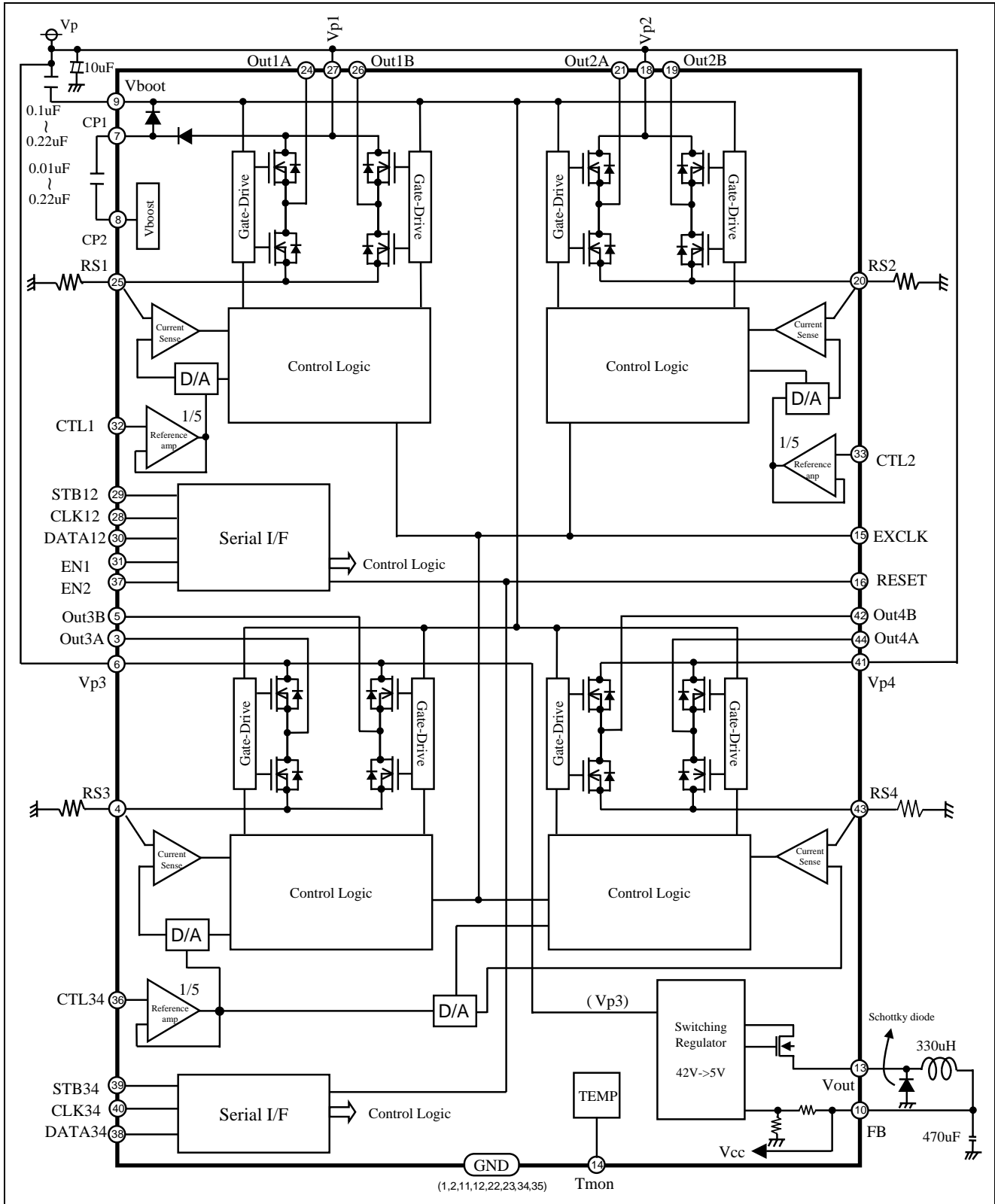

*RS resistance is setting up in the limits which does not exceed Iout Max.

Pin Function

TERMINAL	SYMBOL	TERMINAL FUNCTION	TERMINAL	SYMBOL	TERMINAL FUNCTION
1	Ground	GND	23	Ground	GND
2	Ground	GND	24	Out1A	Motor drive output1A
3	Out3A	Motor drive output3A	25	RS1	Current sense 1
4	RS3	Current sense 3	26	Out1B	Motor drive output1B
5	Out3B	Motor drive output3B	27	Vp1	Motor power supply 1
6	Vp3	Motor power supply 3	28	CLK12	Clock in terminal 12
7	CP1	Coupling capacitor1	29	STB12	Stand by mode select 12
8	CP2	Coupling capacitor2	30	DATA12	Data input terminal 12
9	Vboot	Bootstrap voltage	31	EN1	Enable 1
10	FB	Feed back	32	CTL1	Reference control 1
11	Ground	GND	33	CTL2	Reference control 2
12	Ground	GND	34	Ground	GND
13	Vout	Voltage output	35	Ground	GND
14	(Tmon)	Temperature monitor	36	CTL34	Reference control 34
15	EXCLK	External input terminal	37	EN2	Enable 2
16	RESET	RESET	38	DATA34	Data input terminal 34
17	NC	No contact	39	STB34	Stand by mode select 34
18	Vp2	Motor power supply 2	40	CLK34	Clock in terminal 34
19	Out2B	Motor drive output2B	41	Vp4	Motor power supply 4
20	RS2	Current sense 2	42	Out4B	Motor drive output4B
21	Out2A	Motor drive output2A	43	RS4	Current sense 4
22	Ground	GND	44	Out4A	Motor drive output4A

Absolute Maximam Rating

SYMBOL	PARAMETER	CONDITIONS	RATING	UNIT
VBOOT	Bootstrap voltage		65	V
VP	Motor power supply		52	V
Vcc	Power supply		6.5	V
Iout	Motor output current		2.0	A
Vin	Input voltage of terminals		-0.3 to 6.5	V
Pt	Power dissipation	Ta=25°C, Grass epoxy board base	2.5W	W
Kθ	Thermal dissipation	Ta=25°C, Grass epoxy board base	40	°C/W
Tj	Junction temperature		150	°C
Topr	Movement Circumference temperature		-20 to 75	°C
Tstg	Storage temperature		-40 to 125	°C

Recommended Operating Conditions

(Ta =25°C)

SYMBOL	PARAMETER	LIMITS			UNIT
		MINIMUM	TYPICAL	MAXIMUM	
VBOOT	Bootstrap voltage	—	52.6	61.2	V
Vref	Control Voltage	0.1	2.5	2.9	V
VP	Motor power supply	19.0	—	46.2	V
* Iout	Motor Current supply	—	1.2	1.5	A
EXTCLK	EXTCLK input frequency	1.8	4.0	6.1	MHz

* Junction temperature at 150°C within

Logic Input Terminal

SYMBOL	CONDITION
STB	Pull Down
CLK	Pull Down
DATA	Pull Down
EN1	Pull Down
EN2	Pull Down
RESET	Pull Down

Electrical Characteristics

(Ta=25°C, VP=42V unless otherwise noted)

SYMBOL	PARAMETER	CONDITIONS	LIMITS			UNIT
			MINIMUM	TYPICAL	MAXIMUM	
Common Block						
ICC-L	Vcc standby current	VCC=5V, Circuit current of Motor stopping	—	5.5	7	mA
IM-L	Motor stop current	VP=42V, Circuit current of Motor stopping	—	6.0	7.5	mA
Vboot	Bootstrap voltage		—	52.6	61.2	V
Fcp1	Bootstrap frequency		150	200	250	kHz
Lvoldl	Regulator voltage detector	The case of supply voltage decreasing	—	LvoldH -Vhys	—	V
LvoldH	Regulator voltage detector	The case of supply voltage increasing	4.18	4.4	4.62	V
Vhys	Vhys		180	200	220	mV
Tmon	Tmon Voltage	Ta=25°C	710	740	770	mV
[Power Block]						
Ron1	Output RDS(ON)	Total of top and bottom (Ta=25°C)	—	1.1	1.4	Ω
Ron2	Output RDS(ON)	Total of top and bottom (Ta=25°C)	—	1.1	1.4	Ω
[Logic Input Terminal]						
VinH	Serial port input voltage High		2	—	REGout	V
VinL	Serial port input voltage Low		0	—	0.8	V
IinH	Serial port input current High	V force:5V	50	100	200	μA
IinL	Serial port input current Low	V force:0V	-10	0	+10	μA
[Serial port]						
fclk	Serial port clock frequency	CLK12, CLK34	—	—	20	MHz
tset	Serial port setup time		12.5	—	—	nS
thold	Serial port hold time		10	—	—	nS
[Switching regulator]						
REGout1	5V regulator output voltage1	Load current :300mA VP voltage :10V to 47V	4.75	5.00	5.25	V
Fclk-Reg	Clock frequency		75	100	125	kHz
Rds(on)-Reg	Sw.Reg.-ON		—	0.7	—	Ω
Sfts	Soft Start		5	10	15	ms
Climit	Output Limits Voltage	Load current : 600mA to 1.2A	—	4.75	—	V
Climit	Cut of FB Voltage		0.8	1.2	1.5	A
Iout	REG Output Current		—	300	500	mA
EFFI1	Efficiency (Design Value)	VP=42V L=330uH C=470μF Iout=300mA	—	70	—	%
EFFI2	Efficiency (Design Value)	VP=15 VL=330uH C=470μF Iout=300mA	—	80	—	%

(Ta=25°C, VP=42V unless otherwise noted)

SYMBOL	PARAMETER	CONDITIONS	LIMITS			UNIT
			MINIMUM	TYPICAL	MAXIMUM	
Exdt	External PWM Delay Time	Iout=±1A 50% to 90%				ns
		PWM change to source ON	200	500	800	
		PWM change to source OFF	50	100	200	
		PWM change to sink ON	200	500	800	
		PWM change to sink OFF	50	100	200	
		Phase change to source ON	200	500	800	
		Phase change to source OFF	50	100	200	
		Phase change to sink ON	200	500	800	
		Phase change to sink OFF	50	100	200	
		Svol1	Sense Voltage1	Current ratio 100% Vref(CTL)=2.0V	384	
Svol2	Sense Voltage2	Current ratio 26.08% Vref(CTL)=2.0V	93	104	115	mV
Ictl	Control Input Current	CTL-GND Current	0.5	3	5	μA

Thermal Characteristics

SYMBOL	PARAMETER	Function start temperature of IC			UNIT
		MINIMUM	TYPICAL	MAXIMUM	
TSD	Thermal shut down	—	165	—	°C
ΔHys	TSD Hys		35		°C

SYMBOL	PARAMETER	CONDITIONS	LIMITS			UNIT
			MINIMUM	TYPICAL	MAXIMUM	
Motor Block						
[Power Block]						
Ron1-125	Output RDS(ON)	Total of top and bottom (Ta=125°C)	—	1.65	2.0	Ω
Ron2-125	Output RDS(ON)	Total of top and bottom	—	1.65	2.0	Ω
ΔTmon	Tmon		-1.90	-1.72	-1.55	mV/°C

Switching Regulator

Explanation

1. When using it usually through a switching regulator It is as a 2/15- page block diagram between Vout and FB terminal. Please connect a coil capacitor diode .
2. When S/W- REG is not used but voltage is given to a direct FB terminal from the exterior A coil capacitor diode is unnecessary.

Protection function

When voltage is given to a direct FB terminal from the exterior, Current can decrease by about 1mA at the time of Vp standby.

- Vout terminal
1. It has the Gnd short protection function at the time of starting.l
 2. It does not have the Gnd short protection function under operation.
- FB terminal
1. The Gnd short protection function at the time of starting serves as only a current limit.
 2. During operation, it has the function to make Vout turn off by combined use of current limit detection and a Low Voltage detection machine.

Sequence of operation at the time of starting.

Usually, a state: Power supply injection → With no GND short → Vout-FB and charge pump operation

GND short state: Power supply injection → GND short → Vout-FB un-operating Charge pump operation

Sequence during operation.

Vout GND short: Vout operation → GND short judging → Vout-FB and charge pump operation

FB GND short: FB operation → Current limit operation → GND short judging → Vout-FB OFF. Charge pump operation

When FB voltage becomes less than [more than 1us4.2V] by current limit detection It becomes a GND short judging and Vout is made to turn off.

- *1 GND short detection function: GND short detection performs GND short detection at the time of starting, It does not have the GND short detection function under operation.

A sequence of operation

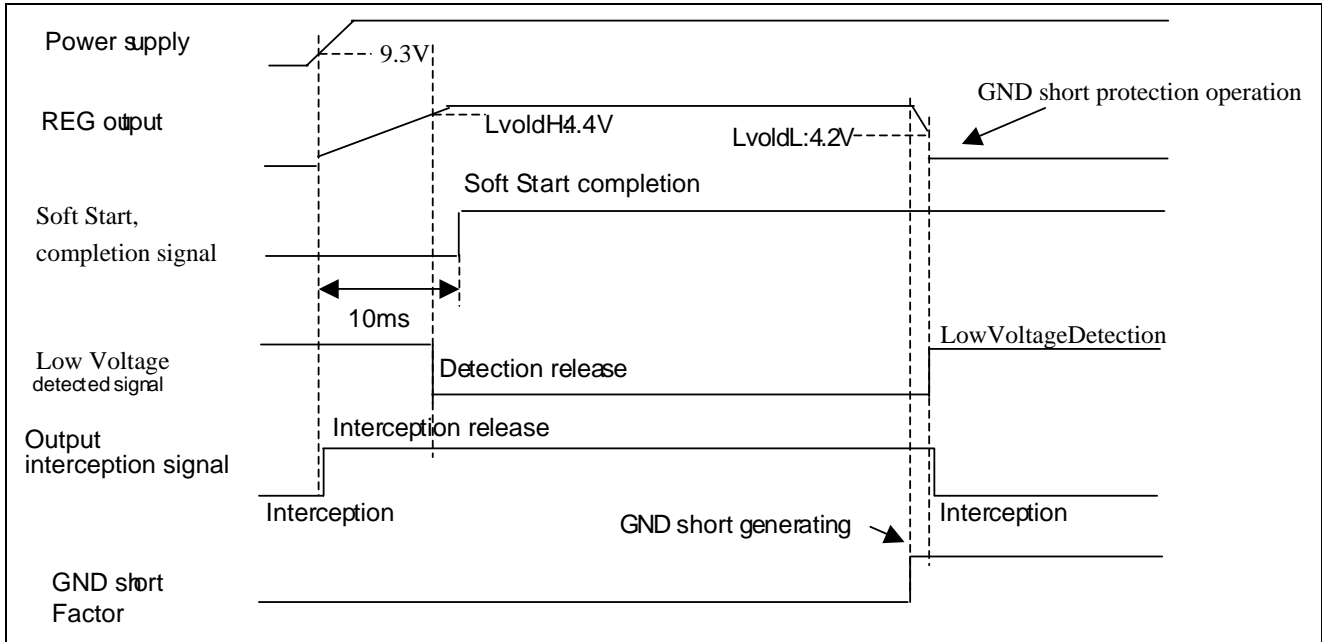

Function setup (all initial value is 0, At TSD it is all 0) RESET initialization = "H"

Ch1:

	OUT1	OUT2	OUT1,2
D0	Blank Time LSB	Blank Time LSB	OUT 2 Internal PWM Mode
D1	Blank Time MSB	Blank Time MSB	OUT2 External PWM Mode
D2	Off Time LSB	Off Time LSB	OUT 2 Phase
D3	Off Time Bit1	Off Time Bit1	OUT 2 DAC LSB
D4	Off Time Bit2	Off Time Bit2	OUT 2 DAC Bit 2
D5	Off Time Bit3	Off Time Bit3	OUT 2 DAC Bit 3
D6	Off Time MSB	Off Time MSB	OUT 2 DAC Bit MSB
D7	Fast Decay Time Bit LSB	Fast Decay Time Bit LSB	OUT 1 internal PWM Mode
D8	Fast Decay Time Bit 1	Fast Decay Time Bit 1	OUT 1 External PWM Mode
D9	Fast Decay time Bit 2	Fast Decay time Bit 2	OUT 1 Phase
D10	Fast Decay time MSB	Fast Decay time MSB	OUT 1 DAC LSB
D11	Sync.Rect.Control	Sync.Rect.Control	OUT 1 DAC Bit 2
D12	Sync.Rect.Enable	Sync.Rect.Enable	OUT 1 DAC Bit 3
D13	Don't care	Don't care	OUT 1 DAC Bit MSB
D14	Word Select 0=0	Word Select 0=1	Word Select 0=0
D15	Word Select 1=0	Word Select 1=0	Word Select 1=1

Ch2:

	OUT3,4	For TEST	OUT3,4
D0	Blank Time LSB	For TEST	OUT 4 Internal PWM Mode
D1	Blank Time MSB	For TEST	Don't care
D2	Off Time LSB	For TEST	OUT 4 Phase
D3	Off Time Bit1	For TEST	OUT 4 DAC LSB
D4	Off Time Bit2	For TEST	OUT 4 DAC Bit 2
D5	Off Time Bit3	For TEST	OUT 4 DAC Bit 3
D6	Off Time MSB	For TEST	OUT 4 DAC Bit MSB
D7	Fast Decay Time Bit LSB	For TEST	OUT 3 internal PWM Mode
D8	Fast Decay Time Bit 1	For TEST	Don't care
D9	Fast Decay time Bit 2	For TEST	OUT 3 Phase
D10	Fast Decay time MSB	For TEST	OUT 3 DAC LSB
D11	Sync.Rect.Control	For TEST	OUT 3 DAC Bit 2
D12	Sync.Rect.Enable	For TEST	OUT 3 DAC Bit 3
D13	Don't care	For TEST	OUT 3 DAC Bit MSB
D14	Word Select 0=0	Word Select 0=1	Word Select 0=0
D15	Word Select 1=0	Word Select 1=0	Word Select 1=1

* RESET Early Condition = "H"

Serial port Write Timing

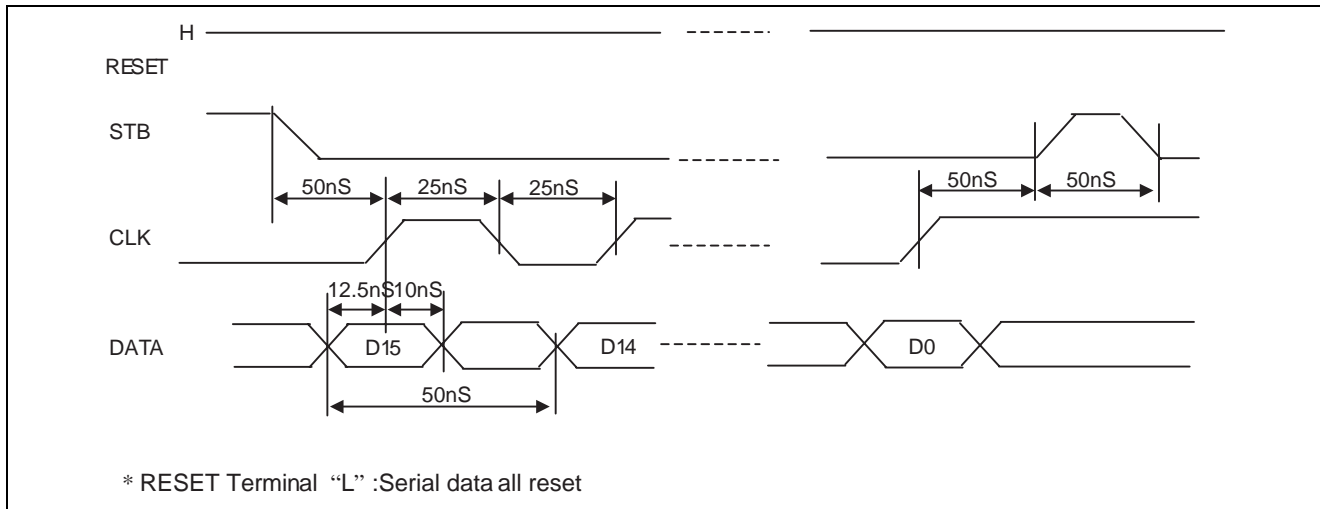

A motor control logic condition and explanation

- 1, Data setup
 - 1-1, Data taking in: CLK rising edge
 - 1-2, Data input 1: It carries out in order of D15 - >D0.
 - 1-3, Data input 2: A Mode setup is performed after initial setting.
 - 1-4, Every 16 bits, it is a STB signal and it is Closed.
 - 1-5, A data setup of Ch2 For Test is not performed.
 - 1-6, Sync.Rect.Control "Active" At the time of a setup, The inside of Fast Decay performs negative voltage detection. FET is set to all OFF when current flows in the right direction.
- 2, RESET terminal

Low: All data reset(All FET OFF)High :Data setup Standby state

When a RESET terminal is set to "L" and a Motor drive is performed, A REST terminal is set to "H" and serial data is re inputted.

Internal logic reset is Logic composition of a RESET terminal and a Low Voltage detection machine is performed. When rapid high load is in FB, a Low Voltage detection machine outputs "L", Internal logic is reset when an output does not return to less than 1 μ s at "H."

RESET terminal "L" ·Internal logic will be in an initial state.(All FET serves as all OFF)
·A S/W- REG part continues operation.
- 3, EN terminal

Low: External PWM Mode Slow Decay or Fast Decay
Off Time ·Fast Decay Time: Sleep

A current detection condition setup at the time of Decay is performed by Sync.Rect.Control Active or Passive. However, current detection is effective only at the time of Fast Decay.(Slow is invalid.)

High :Internal PWM Mode Motor drive state FET ON- >OFF - >ON
- 4, Motor drive

Motor drive :RESET terminal "H" EN terminal "H" It drives after a Mode Data setup.

Motor STOP :RESET terminal "L" is STOP.

RESET terminal "H" EN terminal "L": It is set to Decay by External PWM Mode. All FETOFF comes after setting current detection.

EN is not related to "L or H" in early stages. It FET all turns off till control logic initial setting and the completion of a Mode setting. EN is always after control logic initial setting and the completion of a Mode setting at "L.", If it is External PWM Slow Decay Mode, it is Start about Slow Decay.
(It FET all turns off at the time of Fast Decay Mode.)

After control logic initial setting and the completion of a Mode setting, FET is set to being turned on by EN "H" and it is compulsorily set to Decay Mode by EN "L."

However, even if a setup of External PWM Slow Decay Mode is EN "L", it is reflected.
- 5, Current detection by Decay

The conditions which perform current detection by Decay

Internal PWM: Sync.Rect.EnableControl1 "H", Inside of Fast Decay in Mixed Decay Mode

External PWM: Sync.Rect.EnableControl1 "H", Fast Decay Mode

In addition, Decay current detection is not performed on conditions.

Internal PWM: It changes to Decay from FET ON by the current detection COM., Fast Decay Time-OffTime starts in this stage. It is Start about the current detection in Decay, Fast Decay Time as a trigger. Detection is stopped after Fast Decay Time completion.

When setting Decay current is detected during Fast Decay time, FET is all turned off only within Fast Decay time. It is referred to as Slow Decay till OFF Time completion after Fast Decay completion.

External PWM: With EN terminal "L", it goes into Regeneration Mode compulsorily. Decay current detection is Started to a trigger for the signal of EN "L." Detection is continued until the reversal signal from COM comes out. Decay current detection serves as [EN] STOP by "H", and FET is turned on

BlankTime of OUT1•OUT2 & OUT3•OUT4

D0	D1	BLANK TIME
0	0	4/ fosc
0	1	6/ fosc
1	0	12/ fosc
1	1	24/ fosc

Fixed-Off Time control of OUT1-OUT2 & OUT3•OUT4
With D2-D6

$$T_{off} = (8[1+N]/f_{osc}) - 1/f_{osc}$$

Where N=0...31

Fast Decay Time control of OUT1-OUT2 & OUT3•OUT4
With D7-D10

$$T_{fd} = (8[1+N]/f_{osc}) - 1/f_{osc}$$

Where N=0...15

Sync.Rect.Control of OUT1•OUT2 & OUT3-OUT4
With D11

	Sync.Rect.	FUNCTION
0	Active	Output turn off when output current reach to zero.
1	Passive	Reversal current bias until vref setting value.

With D12

	Sync.Rect.	FUNCTION
0	Disable	NO Sync.Rect.
1	Enabled	Sync.Rect

Word Select0 / 1 of Ch1 Mode

Select0	Select1	Select Mode
0	0	OUT1
1	0	OUT2
0	1	OUT1/2

WordSelect0 / 1 of Ch2 Mode

Select0	Select1	Select Mode
0	0	OUT3/4- A
1	0	For TEST
0	1	OUT3/4- B

Internal PMWMode select by OUT1/2 & OUT3/4

	Decay Mode
0	Mixed
1	Slow

External PMWMode select by OUT1/2

	Decay Mode
0	Fast
1	Slow

Phase control by OUT1/2

	Phase	OUTA	OUTB
0	Reverse	Low	High
1	Forward	High	Low

DAC

MSB	bit3	Bit2	LSB	Current Ratio(%)
1	1	1	1	100
1	1	1	0	95.65
1	1	0	1	91.3
1	1	0	0	86.95
1	0	1	1	82.61
1	0	1	0	78.26
1	0	0	1	73.91
1	0	0	0	69.56
0	1	1	1	60.87
0	1	1	0	52.17
0	1	0	1	43.48
0	1	0	0	34.78
0	0	1	1	26.08
0	0	1	0	17.39
0	0	0	1	0
0	0	0	0	Disable

$$*ITRIP = V_{REF} \times \text{Current Ratio} / (5 \times R_{SENSE})$$

Motor control functional explanation

- 1, Blank Time
A Mask time setup of the recovery current generated in Motor ON Timing is performed.
- 2, Off Time
The Motor OFF time after Itrip is set up.
- 3, Fast Decay Time
Fast Decay time in Mixed Decay Mode is set up.
(invalid at the time of Slow Decay and External PWM)
- 4, Sync.Rect
 - 4-1, Active :FET is all turned off by current zero among Decay.
 - 4-2, Passive :Reverse current is passed to a Vref setting value,and FET is all turned off after that.
Conditions1 :Internal PWM ·Sync.Rect.EnableControl1 “H ”·Mixed Decay Mode
State1 :Only the inside of Fast Decay is effective.
(When not reaching into Fast Decay at the above- mentioned setting value,it moves Slow Decay)
Conditions2 :External PWM ·Sync.Rect.EnableControl1 “H ”·Fast Decay Mode
- 5, Sync.Rect.Enable
 - 5-1, Disabled :Sync.Rect.EnableControl1 “L ”→Decay by the external diode is performed.
 - 5-2, Enabled :Sync.Rect.EnableControl1 “H ”→Decay with an internal transistor is performed.
- 6, Word Select
The taking- in place of serial data is set up (OUT1,OUT2,OUT1/OUT2).
- 7, Internal PWM
Decay is set up.
Decay Mode :Mixed /Slow
Mixed Decay :Fast Decay to Slow Decay
- 8, External PWM
A Decay setup at the time of the external control by EN terminal
Decay Mode :Fast /Slow
- 9, Phase Control
The direction to which current flows is set up.
Reverse: Phase B→ Phase A
Forward: Phase A→ Phase B
- 10, DAC
The current which FET passes is set up.
Itrip is set up.

Motor control concept figure

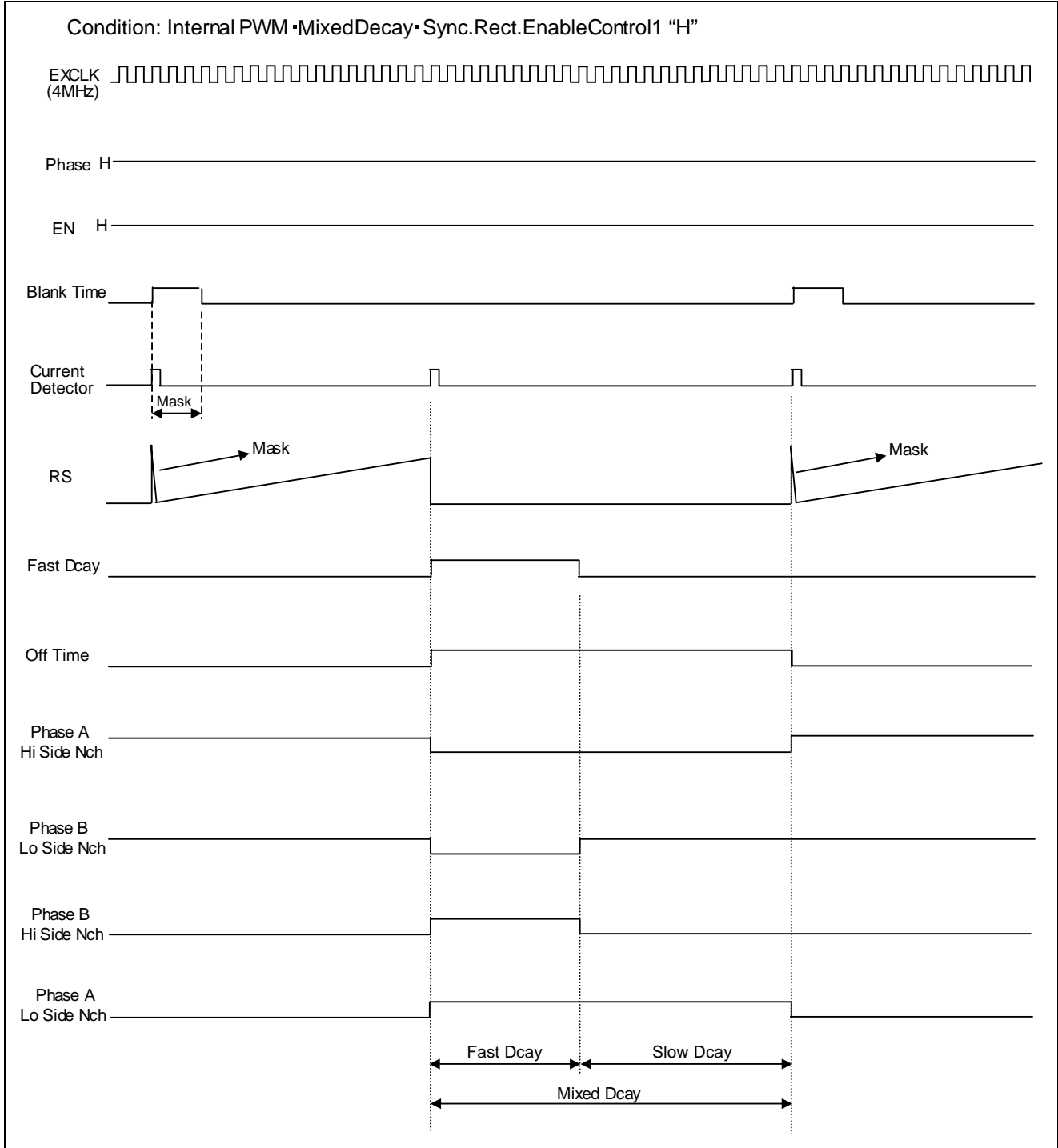

The current detection sequence in Decay

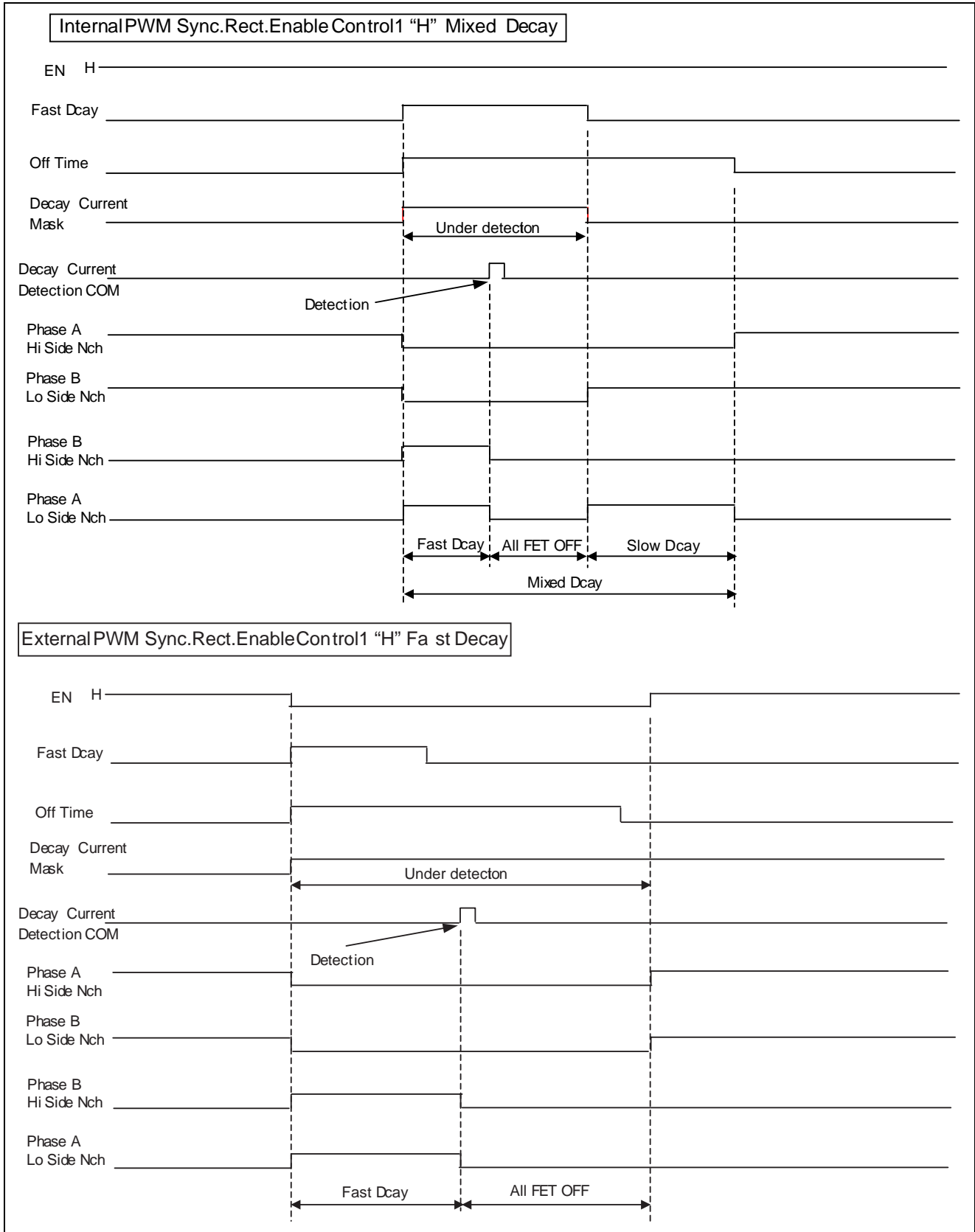

External PWM Mode

External PWM Function

Enable Logic (External PWM)

EN1	OUT1	EN2	OUT2
0	External	0	External
1	Internal	1	Internal

EN1/EN2 L->H: Motor Start(FET ON)
 L=External Mode...>FET OFF(Decay)

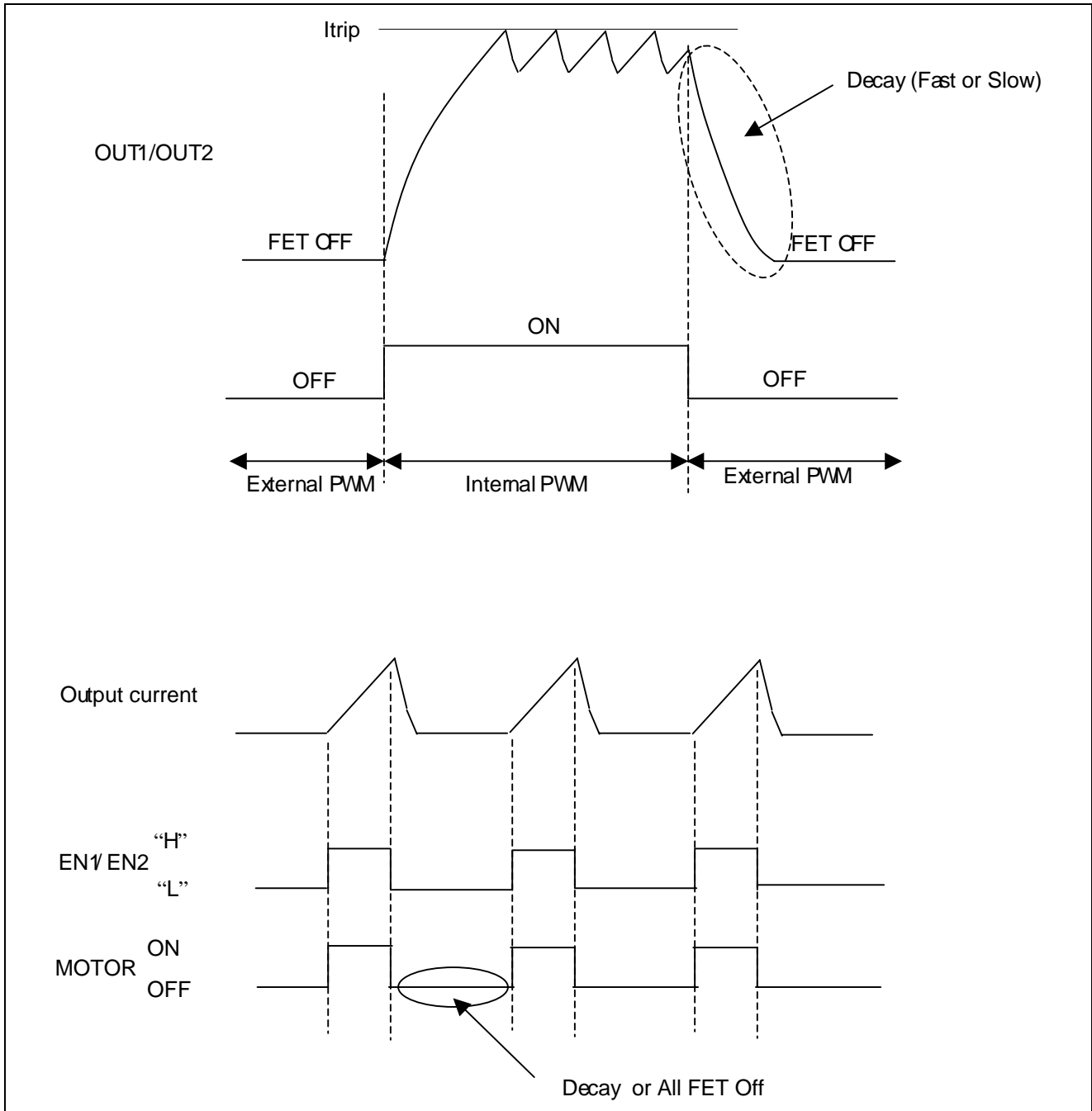

Package Outline



Note: Please contact Renesas Technology Corporation for further details.

Renesas Technology Corp. Sales Strategic Planning Div. Nippon Bldg., 2-6-2, Ohte-machi, Chiyoda-ku, Tokyo 100-0004, Japan

Keep safety first in your circuit designs!

1. Renesas Technology Corp. puts the maximum effort into making semiconductor products better and more reliable, but there is always the possibility that trouble may occur with them. Trouble with semiconductors may lead to personal injury, fire or property damage.
Remember to give due consideration to safety when making your circuit designs, with appropriate measures such as (i) placement of substitutive, auxiliary circuits, (ii) use of nonflammable material or (iii) prevention against any malfunction or mishap.

Notes regarding these materials

1. These materials are intended as a reference to assist our customers in the selection of the Renesas Technology Corp. product best suited to the customer's application; they do not convey any license under any intellectual property rights, or any other rights, belonging to Renesas Technology Corp. or a third party.
 2. Renesas Technology Corp. assumes no responsibility for any damage, or infringement of any third-party's rights, originating in the use of any product data, diagrams, charts, programs, algorithms, or circuit application examples contained in these materials.
 3. All information contained in these materials, including product data, diagrams, charts, programs and algorithms represents information on products at the time of publication of these materials, and are subject to change by Renesas Technology Corp. without notice due to product improvements or other reasons. It is therefore recommended that customers contact Renesas Technology Corp. or an authorized Renesas Technology Corp. product distributor for the latest product information before purchasing a product listed herein.
The information described here may contain technical inaccuracies or typographical errors.
Renesas Technology Corp. assumes no responsibility for any damage, liability, or other loss rising from these inaccuracies or errors.
Please also pay attention to information published by Renesas Technology Corp. by various means, including the Renesas Technology Corp. Semiconductor home page (<http://www.renesas.com>).
 4. When using any or all of the information contained in these materials, including product data, diagrams, charts, programs, and algorithms, please be sure to evaluate all information as a total system before making a final decision on the applicability of the information and products. Renesas Technology Corp. assumes no responsibility for any damage, liability or other loss resulting from the information contained herein.
 5. Renesas Technology Corp. semiconductors are not designed or manufactured for use in a device or system that is used under circumstances in which human life is potentially at stake. Please contact Renesas Technology Corp. or an authorized Renesas Technology Corp. product distributor when considering the use of a product contained herein for any specific purposes, such as apparatus or systems for transportation, vehicular, medical, aerospace, nuclear, or undersea repeater use.
 6. The prior written approval of Renesas Technology Corp. is necessary to reprint or reproduce in whole or in part these materials.
 7. If these products or technologies are subject to the Japanese export control restrictions, they must be exported under a license from the Japanese government and cannot be imported into a country other than the approved destination.
Any diversion or reexport contrary to the export control laws and regulations of Japan and/or the country of destination is prohibited.
 8. Please contact Renesas Technology Corp. for further details on these materials or the products contained therein.
-



RENESAS SALES OFFICES

<http://www.renesas.com>

Renesas Technology America, Inc.

450 Holger Way, San Jose, CA 95134-1368, U.S.A
Tel: <1> (408) 382-7500 Fax: <1> (408) 382-7501

Renesas Technology Europe Limited.

Dukes Meadow, Millboard Road, Bourne End, Buckinghamshire, SL8 5FH, United Kingdom
Tel: <44> (1628) 585 100, Fax: <44> (1628) 585 900

Renesas Technology Europe GmbH

Dornacher Str. 3, D-85622 Feldkirchen, Germany
Tel: <49> (89) 380 70 0, Fax: <49> (89) 929 30 11

Renesas Technology Hong Kong Ltd.

7/F., North Tower, World Finance Centre, Harbour City, Canton Road, Hong Kong
Tel: <852> 2265-6688, Fax: <852> 2375-6836

Renesas Technology Taiwan Co., Ltd.

FL 10, #99, Fu-Hsing N. Rd., Taipei, Taiwan
Tel: <886> (2) 2715-2888, Fax: <886> (2) 2713-2999

Renesas Technology (Shanghai) Co., Ltd.

26/F., Ruijin Building, No.205 Maoming Road (S), Shanghai 200020, China
Tel: <86> (21) 6472-1001, Fax: <86> (21) 6415-2952

Renesas Technology Singapore Pte. Ltd.

1, Harbour Front Avenue, #06-10, Keppel Bay Tower, Singapore 098632
Tel: <65> 6213-0200, Fax: <65> 6278-8001

