

PRELIMINARY

M63840P/FP/KP

8-Unit 500mA Source Type Darlington Transistor-Array With Clamp Diode

* Notice: This is not a final specification.
Some parametric limits are subject to change.

DESCRIPTION

M63840P/FP/KP are eight-circuit output-sourcing Darlington transistor array. The circuits are made of PNP and NPN transistors. Both the semiconductor integrated circuits perform high-current driving with extremely low input-current supply.

FEATURES

- High breakdown voltage ($BV_{CEO} \geq 40V$)
- High-current driving ($I_o(max) = -500mA$)
- With output clamping diodes
- Driving available with TTL output or C-MOS IC output
- Wide operating temperature range ($T_a = -40 \sim +85^\circ C$)
- Output current-sourcing type

APPLICATION

Drives of relays, printers, LEDs, fluorescent display tubes and lamps, and interfaces between MOS-bipolar logic systems and relays, solenoids, of small motors.

FUNCTION

The M63840P/FP/KP each have eight circuits, which are made of input inverters and current-sourcing outputs. The output are made of PNP transistors and NPN Darlington transistors. The PNP transistor base current is constant. A clamping diode is provided between each output and GND. V_s and GND are used commonly among the eight circuits.

The inputs have resistance of $10k\Omega$, and voltage of up to 15V is applicable. Output current is 500mA maximum. Supply voltage V_s is 40V maximum.

The M63840FP/KP is enclosed in a molded small flat package, enabling space-saving design.

PIN CONFIGURATION (TOP VIEW)

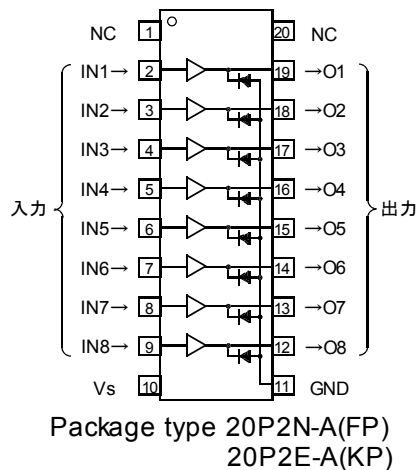
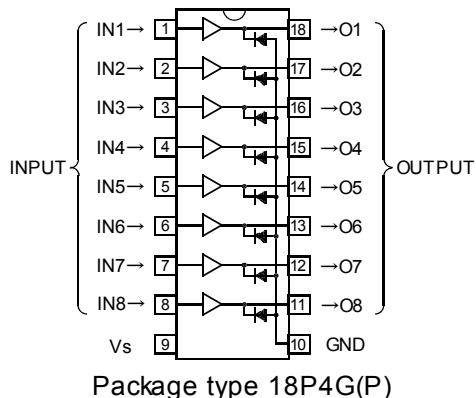

NC: No connection

CIRCUIT DIAGRAM (EACH CIRCUIT)

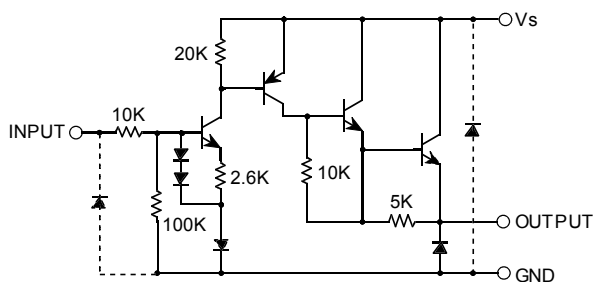

The eight circuits share V_s and GND.

The diode, indicated with the dotted line, is parasitic, and cannot be used.

Unit: Ω

M63840P/FP/KP

8-Unit 500mA Source Type Darlington Transistor-Array With Clamp Diode

ABSOLUTE MAXIMUM RATINGS (Unless otherwise noted, Ta= -40~+85°C)

Symbol	Parameter	Conditions	Ratings	Unit	
V _{CEO}	Collector-emitter v oltage	Output, L	-0.5~+40	V	
V _S	Supply v oltage		40	V	
V _I	Input v oltage		-0.5~+15	V	
I _O	Output current	Current per circuit output, H	-500	mA	
I _F	Clamping diode forward current		-500	mA	
V _R	Clamping diode reverse v oltage		35	V	
P _d	Power dissipation	Ta= 25°C, when mounted on board	M63840P	1.79	W
			M63840FP	1.10	
			M63840KP	0.68	
T _{opr}	Operating temperature		-40~+85	°C	
T _{stg}	Storage temperature		-55~+125	°C	

RECOMMENDED OPERATING CONDITIONS (Unless otherwise noted, Ta= -40~+85°C)

Symbol	Parameter	Limits			Unit	
		min	typ	max		
V _S	Supply v oltage	0	-	40	V	
I _O	Output current (Current per 1 circuit when 8 circuits are coming on simultaneously)	Duty Cycle P: no more then 10% FP: no more then 5% KP: no more then 3%	0	-	-350	mA
			0	-	-100	
V _{IH}	"H" input v oltage	2.0	-	12	V	
V _{IL}	"L" input v oltage	0	-	0.8	V	

ELECTRICAL CHARACTERISTICS (Unless otherwise noted, Ta= 25°C)

Symbol	Parameter	Test conditions	Limits			Unit
			min	typ	max	
I _{S(leak)}	Supply leak current	V _S = 40V, V _I = 0.8V	-	-	100	μA
V _{CE(sat)}	Collector-emitter saturation v oltage	V _S = 10V, V _I = 2V, I _O = -350mA	-	1.7	2.0	V
		V _S = 10V, V _I = 2V, I _O = -100mA	-	1.5	1.8	
I _I	Input current	V _I = 2.4V	-	36	52	μA
		V _I = 3.85V	-	180	260	
I _S	Supply current	V _S = 40V, V _I = 2V (per 1 circuit)	-	-	2.5	mA
V _F	Clamping diode forward v oltage	I _F = 350mA	-	1.3	2.0	V
I _R	Clamping diode reverse current	V _R = 40V	-	-	100	μA

SWITCHING CHARACTERISTICS (Unless otherwise noted, Ta= 25°C)

Symbol	Parameter	Test conditions	Limits			Unit
			min	typ	max	
t _{on}	Turn-on time	C _L = 15pF (note 1)	-	180	-	ns
t _{off}	Turn-off time		-	2200	-	ns

M63840P/FP/KP

8-Unit 500mA Source Type Darlington Transistor-Array With Clamp Diode

NOTE 1 TEST CIRCUIT

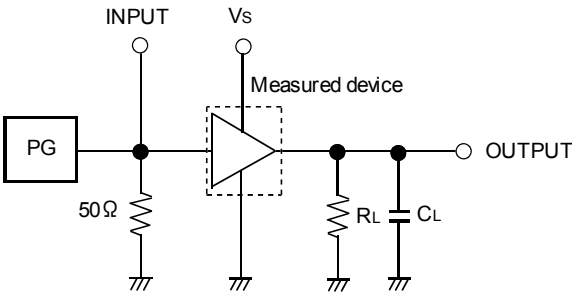

TIMING DIAGRAM

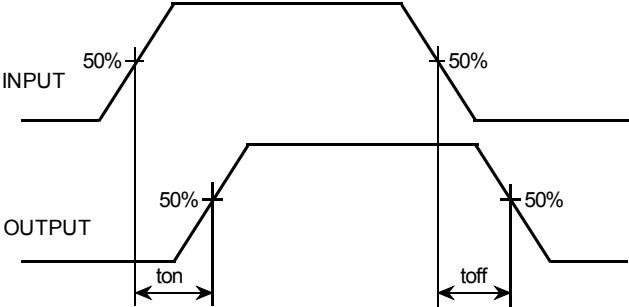

- (1) Pulse generator (PG) characteristics: PRR= 1KHz, $t_w = 10 \mu s$, $t_r = 6ns$, $t_f = 6ns$, $Z_o = 50 \Omega$, $V_i = 0 \sim 2.4V$
- (2) Input-output conditions: $R_L = 100 \Omega$, $V_s = 40V$
- (3) Electrostatic capacity C_L includes floating capacitance at connections and input capacitance at probes.

TYPICAL CHARACTERISTICS

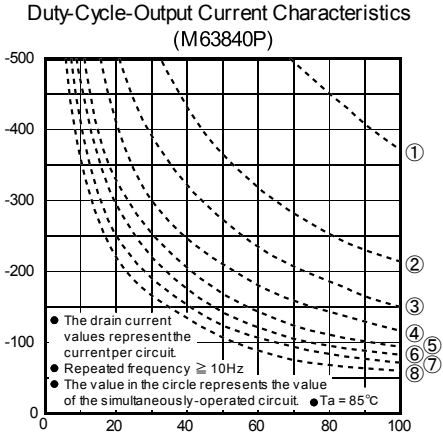
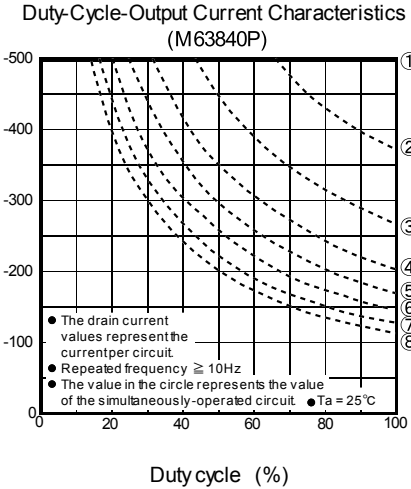
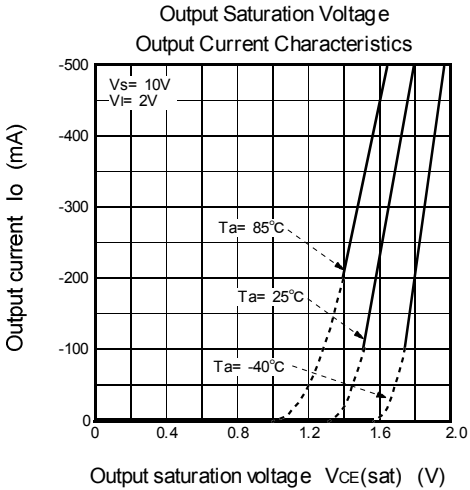
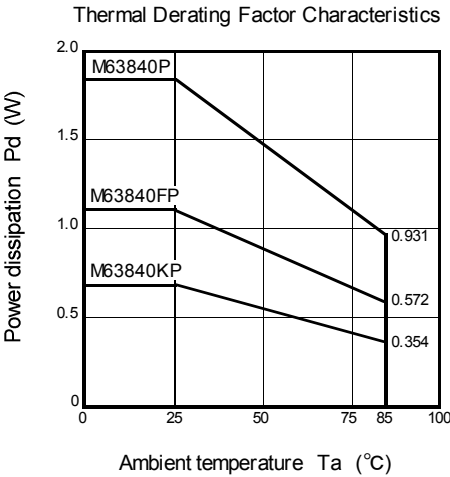

M63840P/FP/KP

8-Unit 500mA Source Type Darlington Transistor-Array With Clamp Diode

Duty-Cycle-Output Current Characteristics
(M63840FP)

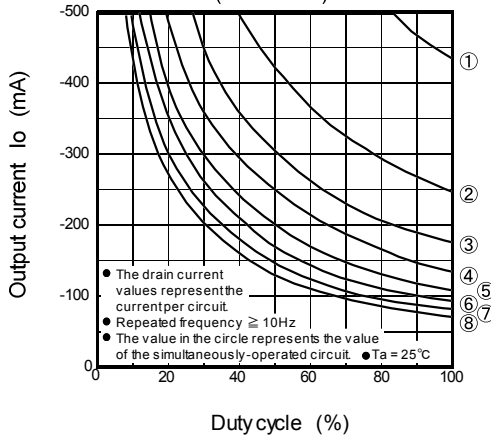

Duty-Cycle-Output Current Characteristics
(M63840FP)

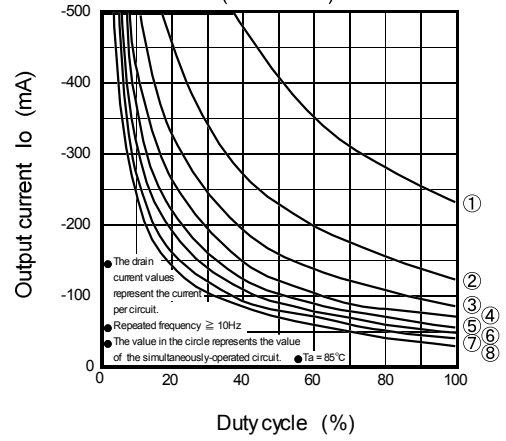

Duty-Cycle-Output Current Characteristics
(M63840KP)

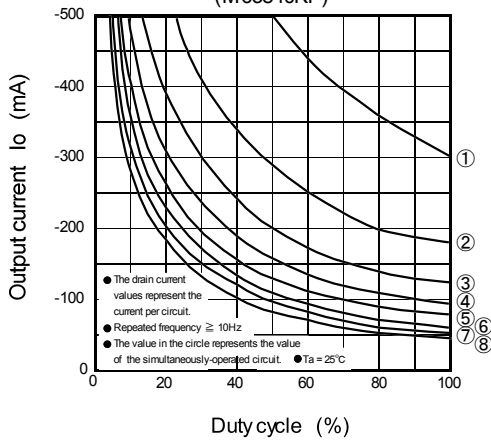

Duty-Cycle-Output Current Characteristics
(M63840KP)

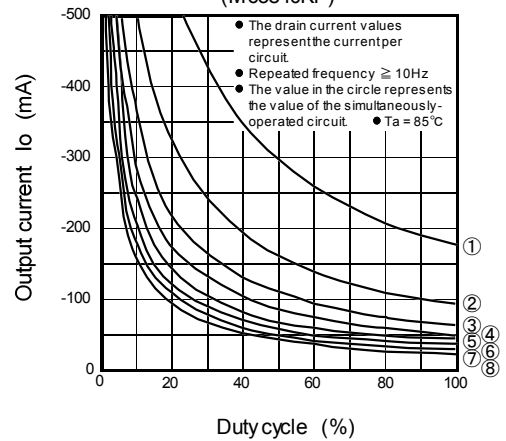

Grounded Emitter Transfer Characteristics

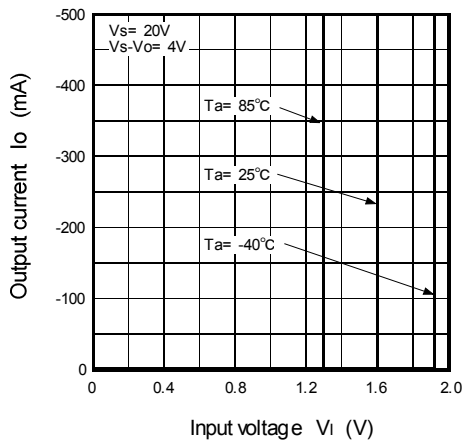

Clamping Diode Characteristics

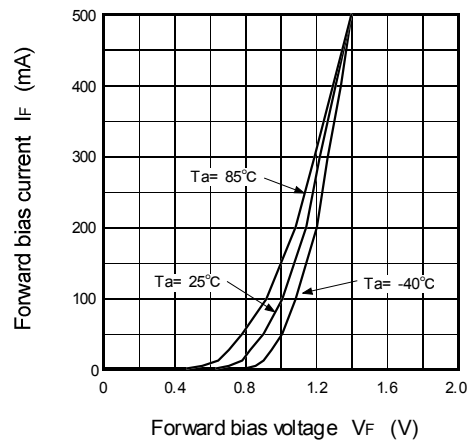

M63840P/FP/KP

8-Unit 500mA Source Type Darlington Transistor-Array With Clamp Diode

Input Characteristics

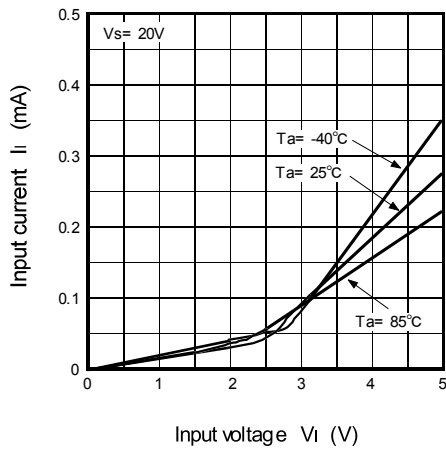

Input Characteristics

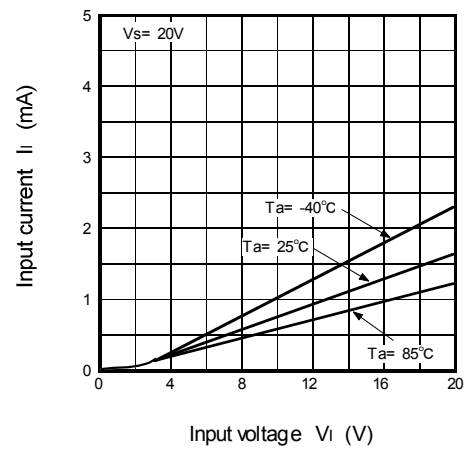

M63840P/FP/KP

8-Unit 500mA Source Type Darlington Transistor-Array With Clamp Diode

18P4G

Plastic 18pin 300mil DIP

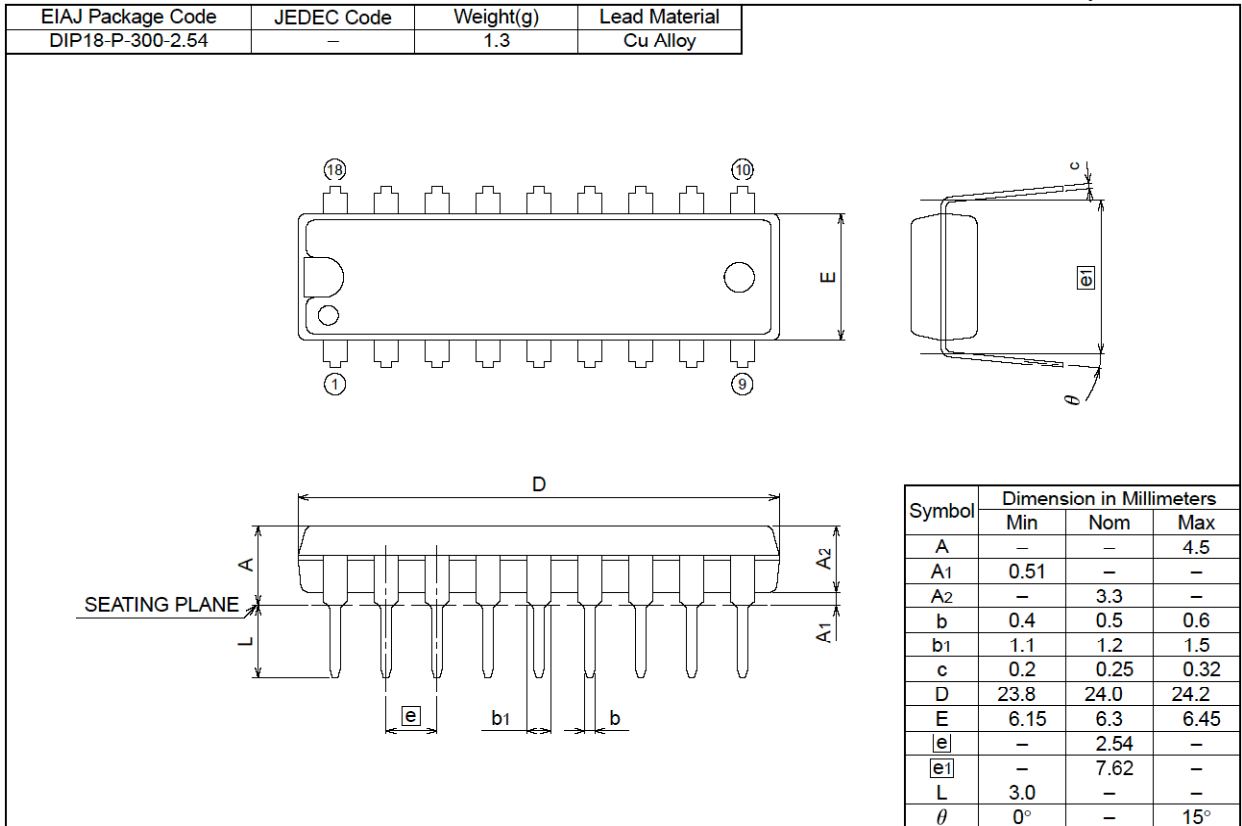

20P2N-A

(MMP)

Plastic 20pin 300mil SOP

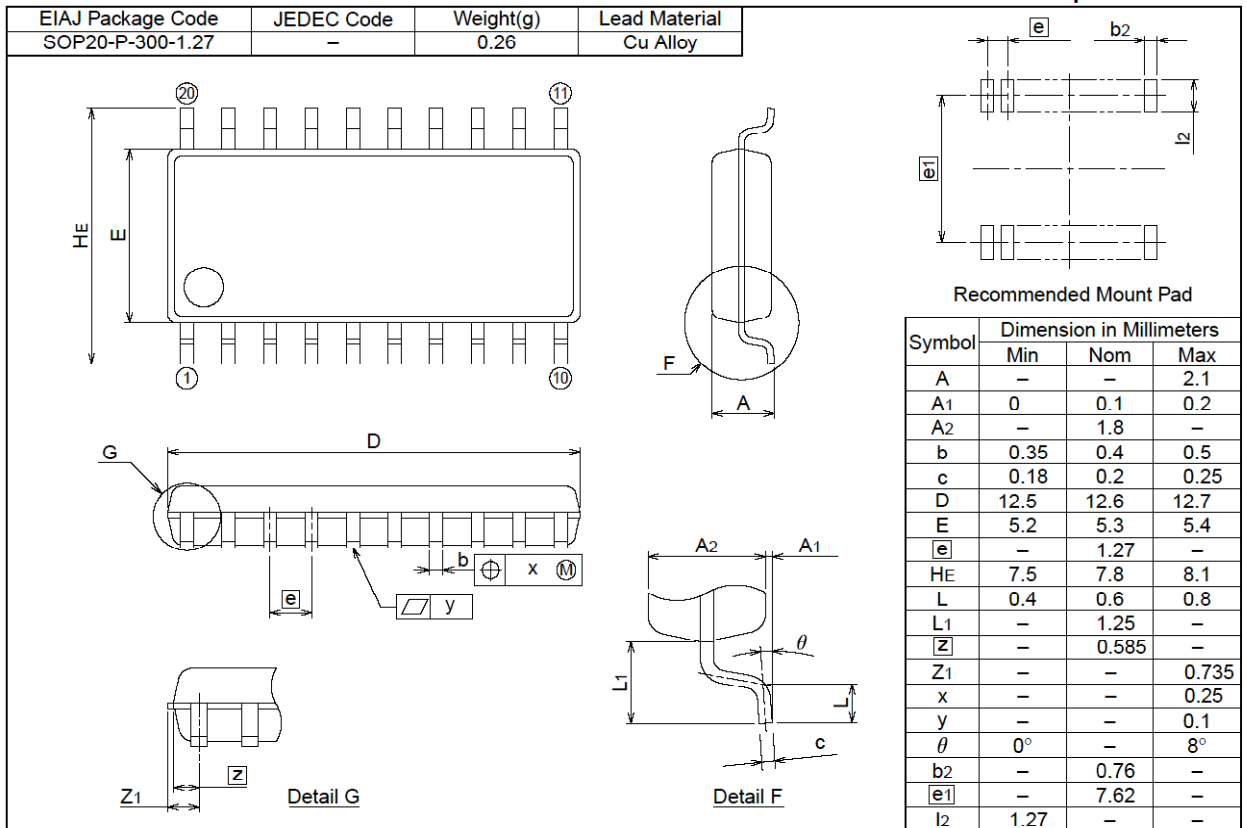

M63840P/FP/KP

8-Unit 500mA Source Type Darlington Transistor-Array With Clamp Diode

20P2E-A

Plastic 20pin 225mil SSOP

EIAJ Package Code	JEDEC Code	Weight(g)	Lead Material
SSOP20-P-225-0.65	-	0.08	Alloy 42

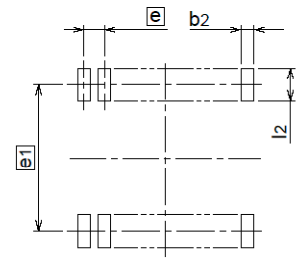
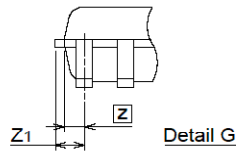
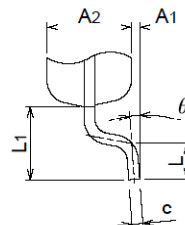
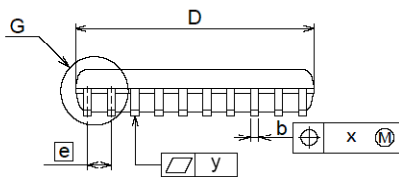
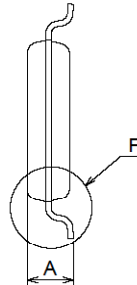
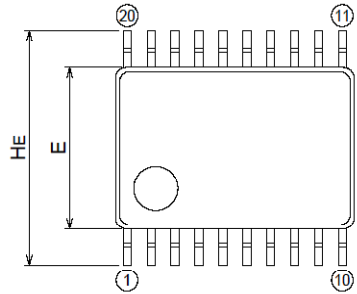

Recommended Mount Pad

Symbol	Dimension in Millimeters		
	Min	Nom	Max
A	-	-	1.45
A1	0	0.1	0.2
A2	-	1.15	-
b	0.17	0.22	0.32
c	0.13	0.15	0.2
D	6.4	6.5	6.6
E	4.3	4.4	4.5
e1	-	0.65	-
HE	6.2	6.4	6.6
L	0.3	0.5	0.7
L1	-	1.0	-
Z	-	0.325	-
Z1	-	-	0.475
x	-	-	0.13
y	-	-	0.1
θ	0°	-	10°
b2	-	0.35	-
e1	-	5.8	-
l2	1.0	-	-