

M65840FP/SP

DIGITAL KEY CONTROLLER

DESCRIPTION

The M65840 is Complementary Metal Oxide Semiconductor Integrated Circuit is used to control the key of music in karaoke* players.

This single chip has all functions necessary for key control.

It is optimal for use in karaoke players, such as radio cassette recorders, mini audio components and video cassette recorders.

* Karaoke : Recorded music to accompany live singing

FEATURES

- All functions necessary for digital key control, such as input/output low-pass filter, A-D, D-A converter, 32k-bit SRAM and control logic circuit, are built in one chip
- Low noise by digital key control
Output noise voltage..... - 84dBm (typ)
- Key is controlled in 32 steps from - 20 to + 20 by microcomputer (One point corresponds to a semitone.)
- Single power supply (5V)
- Built-in automatic reset circuit (The IC is reset as power is turned on.)

RECOMMENDED OPERATING CONDITIONS

- Supply voltage range..... $V_{CC} = 4.5$ to $5.5V$
 Rated supply voltage..... $V_{CC} = 5V$



Outline 28P2W-A(FP)

1.27mm pitch 450mil SOP
(8.4mm × 17.5mm × 2.0mm)

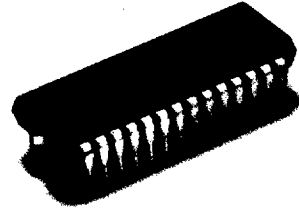

Outline 28P4B(SP)

1.778mm pitch 400mil SDIP
(8.9mm × 28.0mm × 3.8mm)

SYSTEM CONFIGURATION

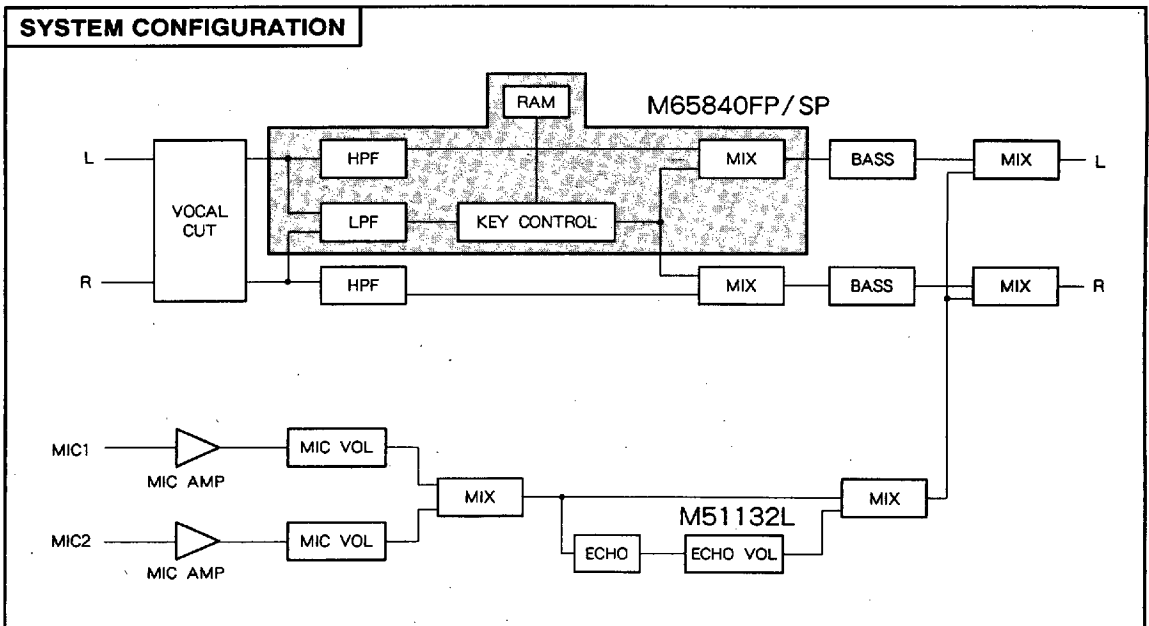

M65840FP/SP

DIGITAL KEY CONTROLLER

PIN CONFIGURATION (TOP VIEW)

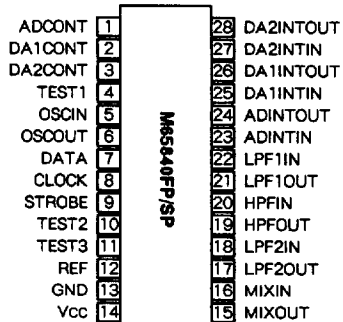

Outline 28P2W-A(FP)
28P4B(SP)

IC INTERNAL BLOCK DIAGRAM

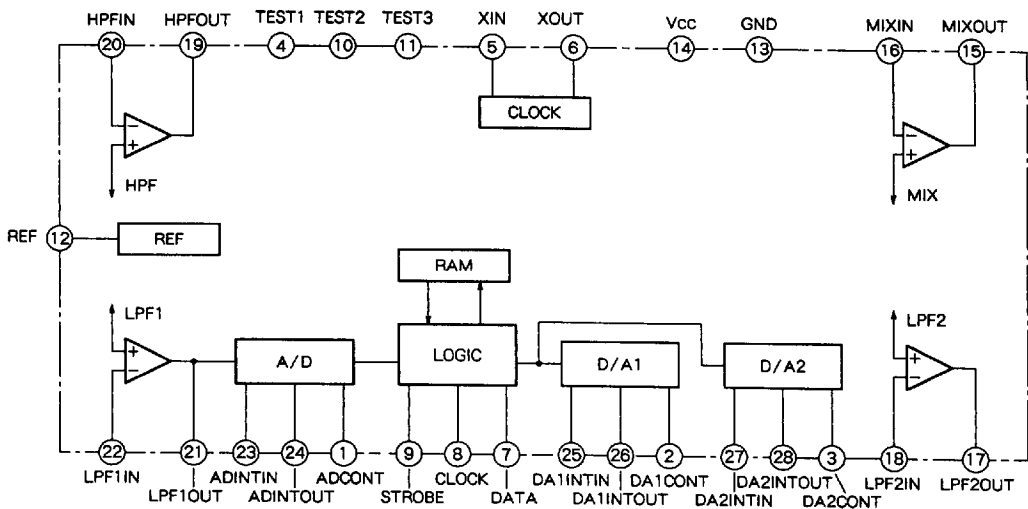

PIN DESCRIPTION

Pin No.	Symbol	Name	Function
①	ADCONT	A/D control	Determines adaptive time constant for A/D conversion by ASM system
②	DA1CONT	D/A1 control	Determines adaptive time constant for D/A1 conversion by ASM system
③	DA2CONT	D/A2 control	Determines adaptive time constant for D/A2 conversion by ASM system
④	TEST1	Test	L: Normal mode H: Test mode
⑤	XIN	Oscillator input	Connected to 16MHz ceramic filter
⑥	XOUT	Oscillator output	
⑦	DATA	Data	Data input via serial bus
⑧	CLOCK	Clock	Clock input via serial bus
⑨	STROBE	Strobe	Strobe input via serial bus
⑩	TEST2	Test	
⑪	TEST3	Test	
⑫	REF	Reference power supply output	Output 1/2Vcc Connected to filter C
⑬	GND	Ground	
⑭	Vcc	Power supply	
⑮	MIXOUT	Mix output	Combines key-controlled low-pass signal and through high-pass signal
⑯	MIXIN	Mix input	
⑰	LPF2OUT	Low-pass filter 2 output	Post-filters following D/A conversion for key control
⑱	LPF2IN	Low-pass filter 2 input	
⑲	HPFOUT	High-pass filter output	High-pass through filter
⑳	HPFIN	High-pass filter input	
㉑	LPF1OUT	Low-pass filter 1 output	Pre-filters precedent to A/D conversion for key control
㉒	LPF1IN	Low-pass filter 1 input	
㉓	ADINTIN	A/D integrator input	Forms A/D conversion integrator with external C
㉔	ADINTOUT	A/D integrator output	
㉕	DA1INTIN	D/A1 integrator input	Forms D/A1 conversion integrator with external C
㉖	DA1INTOUT	D/A1 integrator output	
㉗	DA2INTIN	D/A2 integrator input	Forms D/A2 conversion integrator with external C
㉘	DA2INTOUT	D/A2 integrator output	

ABSOLUTE MAXIMUM RATINGS (Ta = 25 °C unless otherwise noted)

Symbol	Parameter	Ratings	Unit
Vcc	Supply voltage	6.0	V
Icc	Circuit current	100	mA
Vi	Input voltage	- 0.3 to Vcc + 0.3	V
Pa	Power dissipation	1.2(FP) / 1.35(SP)	W
Topr	Operating temperature	-20 to +75	°C
Tstg	Storage temperature	-40 to +125	°C

RECOMMENDED OPERATIONAL CONDITIONS

Symbol	Parameter	Test conditions	Limits			Unit
			Min	Typ	Max	
Vcc	Supply voltage		4.5	5	5.5	V
VIL	Input voltage ("L" level)	Serial pass input	-	-	1	V
VIH	Input voltage ("H" level)	Serial pass input	4	-	-	V
fck	Clock frequency		15.5	16	17.0	MHz

ELECTRICAL CHARACTERISTICS (Vcc = 5V, f = 1kHz, Vi = -15dBm, fck = 16MHz (when key is FO), Ta = 25 °C unless otherwise noted)

Symbol	Parameter	Test conditions	Limits			Unit
			Min	Typ	Max	
Icc	Circuit current	No signals	-	19	50	mA
Gv	Voltage gain		-3	0	3	dB
THD	Output distortion	Vo = -15dBm, 30kHz LPF	-	0.8	2	%
No	Output noise voltage	JIS-A	-	-84	-70	dBm
Vomax	Maximum output voltage	THD = 10%	-1	2	-	dBm

M65840FP/SP

DIGITAL KEY CONTROLLER

FUNCTION

Key Control System :

3-line clocked serial pass control

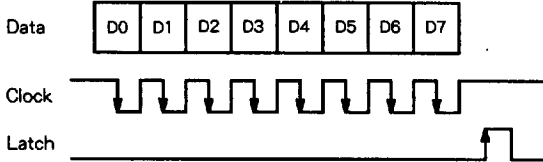

D5	VSC/VMC
H	VSC
L	VMC

D6	MUTE
H	MUTE
L	NORMAL

D7	TEST
H	TEST
L	NORMAL

Key control variations

D0	D1	D2	D3	D4	VMC	VSC
H	H	H	H	H		F + 20
L	H	H	H	H		F + 18
H	L	H	H	H		F + 16
L	L	H	H	H		F + 14
H	H	L	H	H		F + 13
L	H	L	H	H		F + 11
H	L	L	H	H		F + 9
L	L	L	H	H	F + 8	F + 8
H	H	H	L	H	F + 7	F + 7
L	H	H	L	H	F + 6	F + 6
H	L	H	L	H	F + 5	F + 5
L	L	H	L	H	F + 4	F + 4
H	H	L	L	H	F + 3	F + 3
L	H	L	L	H	F + 2	F + 2
H	L	L	L	H	F + 1	F + 1
L	L	L	L	H	F 0	F 0
H	H	H	H	L	F - 1	F - 1
L	H	H	H	L	F - 2	F - 2
H	L	H	H	L	F - 3	F - 3
L	L	H	H	L	F - 4	F - 4
H	H	L	H	L	F - 5	F - 5
L	H	L	H	L	F - 6	F - 6
H	L	L	H	L	F - 7	F - 7
L	L	L	H	L	F - 8	F - 8
H	H	H	L	L		F - 9
L	H	H	L	L		F - 11
H	L	H	L	L		F - 12
L	L	H	L	L		F - 13
H	H	L	L	L		F - 14
L	H	L	L	L		F - 16
H	L	L	L	L		F - 18
L	L	L	L	L		F - 20

Note 1. VMC ensures better sound quality in key variation between - 4 and + 4, while VSC is suitable for key variation beyond this range.

2. Sampling frequency for A-D, D-A conversion is different between VMC and VSC. Noise may be produced when VMC is switched to VSC or the other way around. We recommend that mute be provided as shown above (D6) to prevent it.

3. When power is turned on, key is set to F0 and mode is set to VMC by automatic reset function.

APPLICATION DIRECTIONS

① Input level

The maximum output voltage at low-pass filters, high-pass filters and mixing amplifier is 1.2Vrmsmin(+ 4dBm), and that at digital key control circuit is 0.7Vrmsmin(- 1dBm).

Therefore, the adequate reference signal level is approximately 150mVrms(- 14dBm).

When the reference signal is on this level, voltage at the head rooms is 18dB and 13dB, respectively.

The voltage at low-pass filters, high-pass filters and mixing amplifier can be attenuated or amplified within a limit of ± 10dB according to external constants. This mechanism can be used to obtain an adequate reference signal level.

When connected to operational amplifier M5201 having a switch as shown below, this IC is able to handle inputs at large amplitude(2Vrms), such as those from compact discs and laser discs, as well as ensures better sound quality when the key control is off.

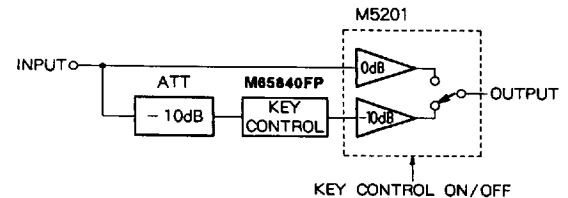

② Power

Connect a filter capacitor of at least 47μF and a pass control of approximately 0.1μF near power-GND pin (within a radius of 2cm)

TEST CONDITIONS

SWITCHING CONDITIONS

RECOMMENDED OPERATING CONDITIONS

Symbol	Parameter	Test conditions	SWITCH		
			14	30	
I _{cc}	Circuit current	No signal	2	2	
G _v	Voltage gain between input and output		1	1	$G_v = 20\log(V_o/V_i)$
THD	Output distortion	30KHz L.P.F	1	1	
No	Output noise voltage	JIS-A	2	2	
V _{omax}	Maximum output voltage	30KHz L. P. F THD=10%	1	1	

TEST CIRCUIT

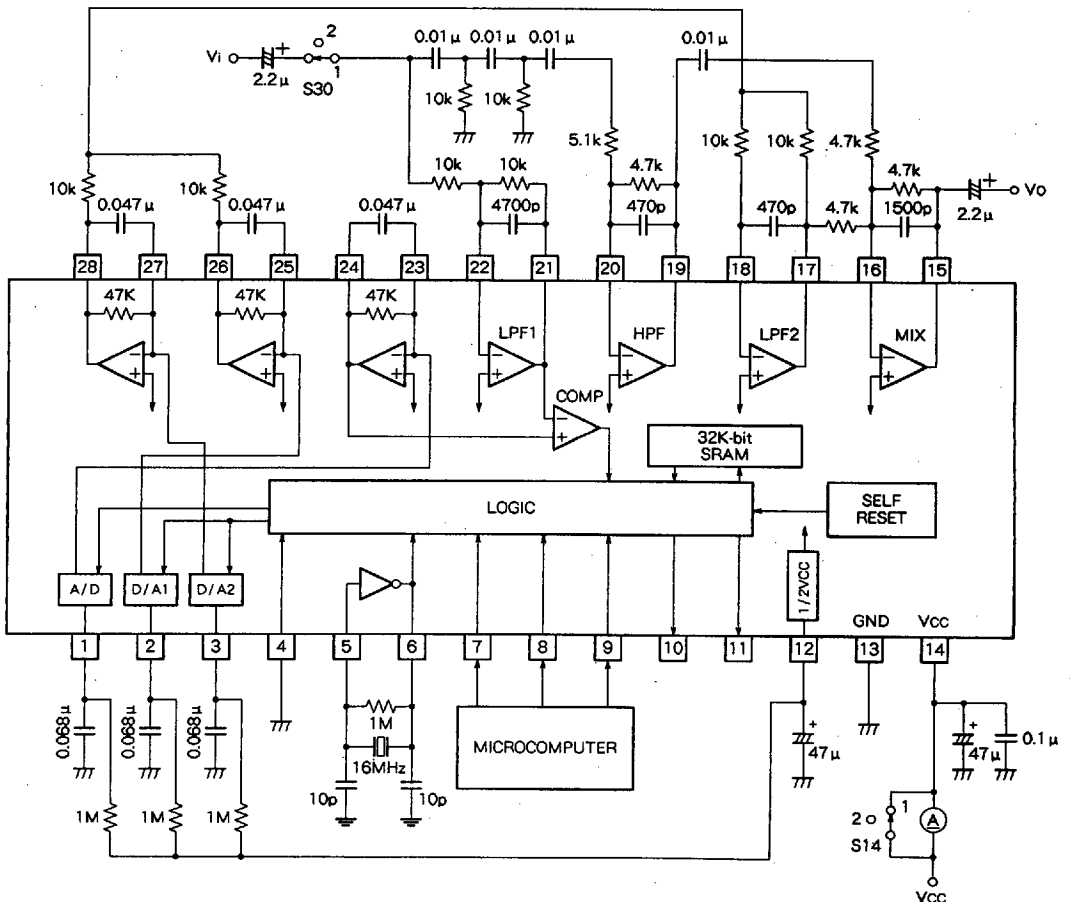

Units Resistance : Ω
Capacitance : F

TYPICAL CHARACTERISTICS

THERMAL DERATING
(MAXIMUM RATING)

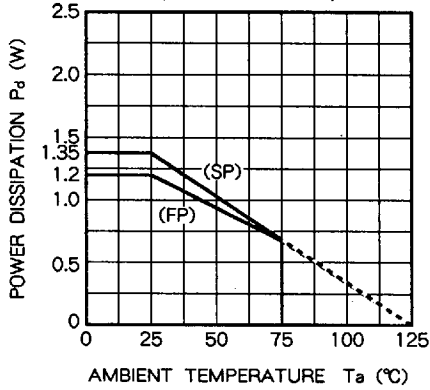

CIRCUIT CURRENT
VS. SUPPLY VOLTAGE

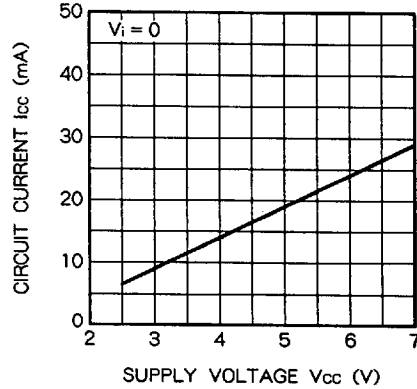

OUTPUT NOISE VOLTAGE
VS. SUPPLY VOLTAGE

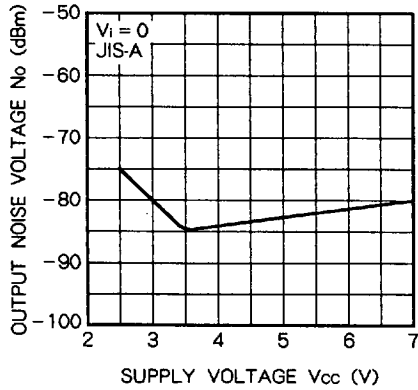

MAXIMUM OUTPUT VOLTAGE
VS. SUPPLY VOLTAGE

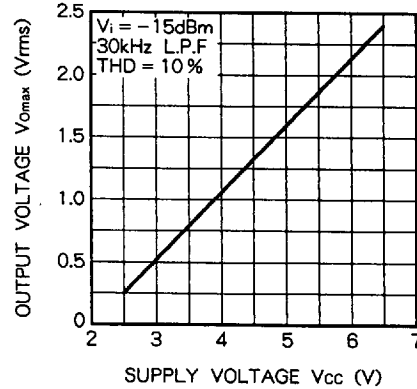

TOTAL HARMONIC DISTORTION
VS. OUTPUT VOLTAGE

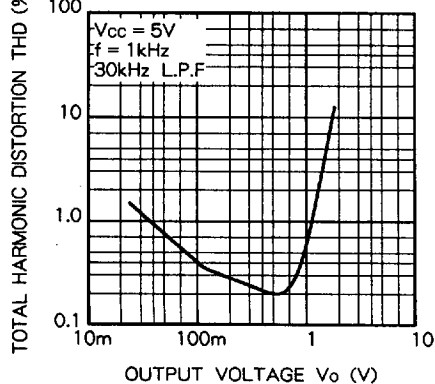

APPLICATION EXAMPLE

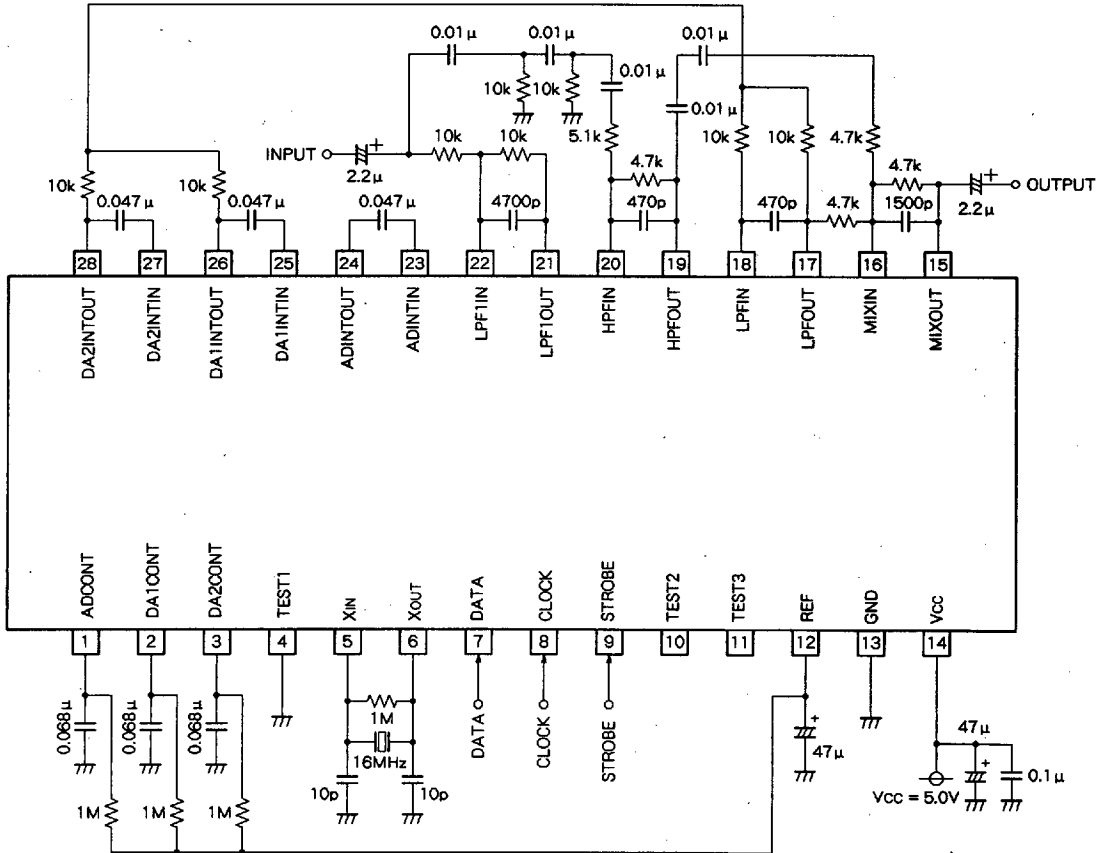

Units Resistance : Ω
Capacitance : F