

M67709

430-470MHz, 12.5V, 13W, FM MOBILE RADIO

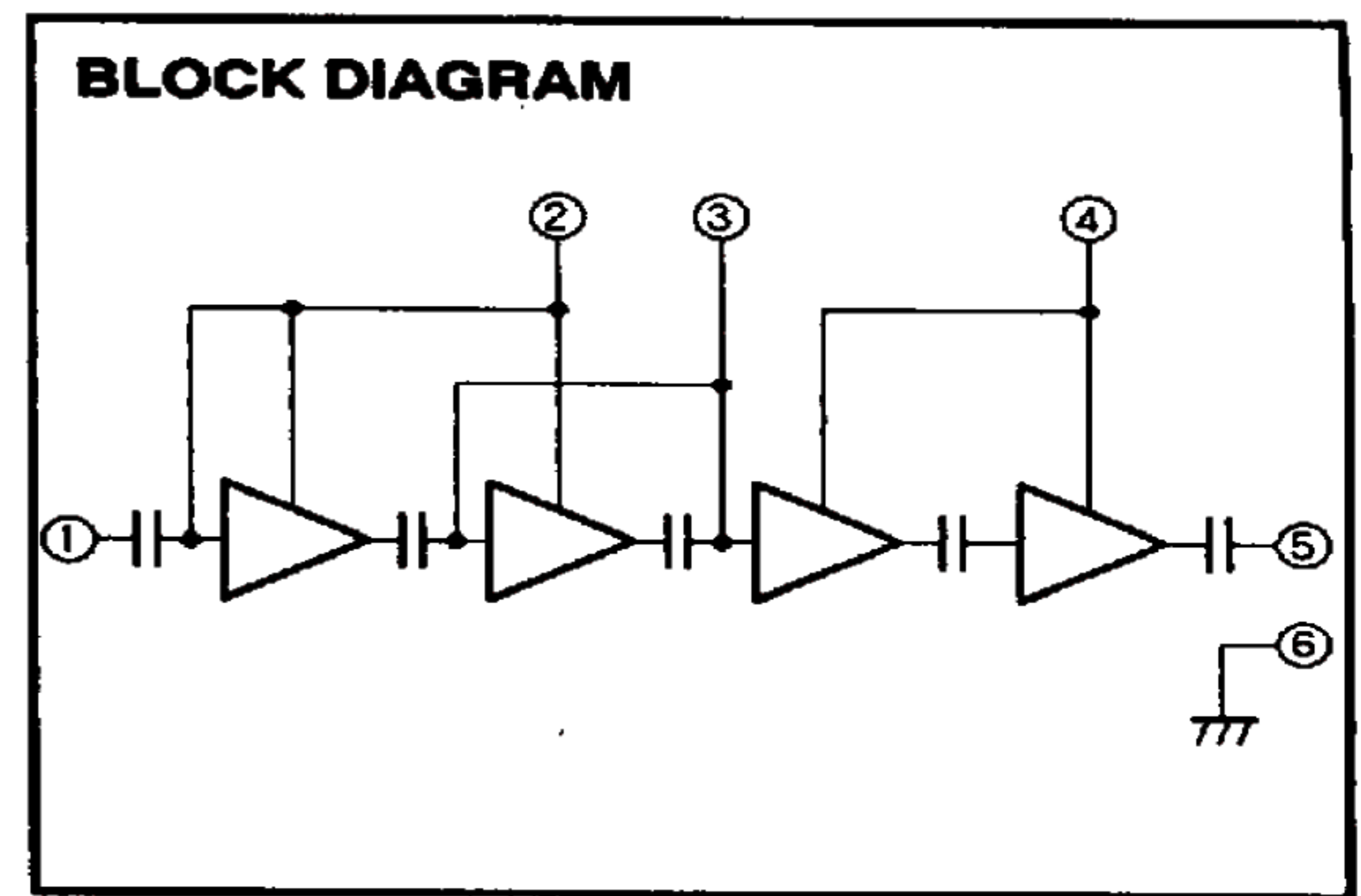
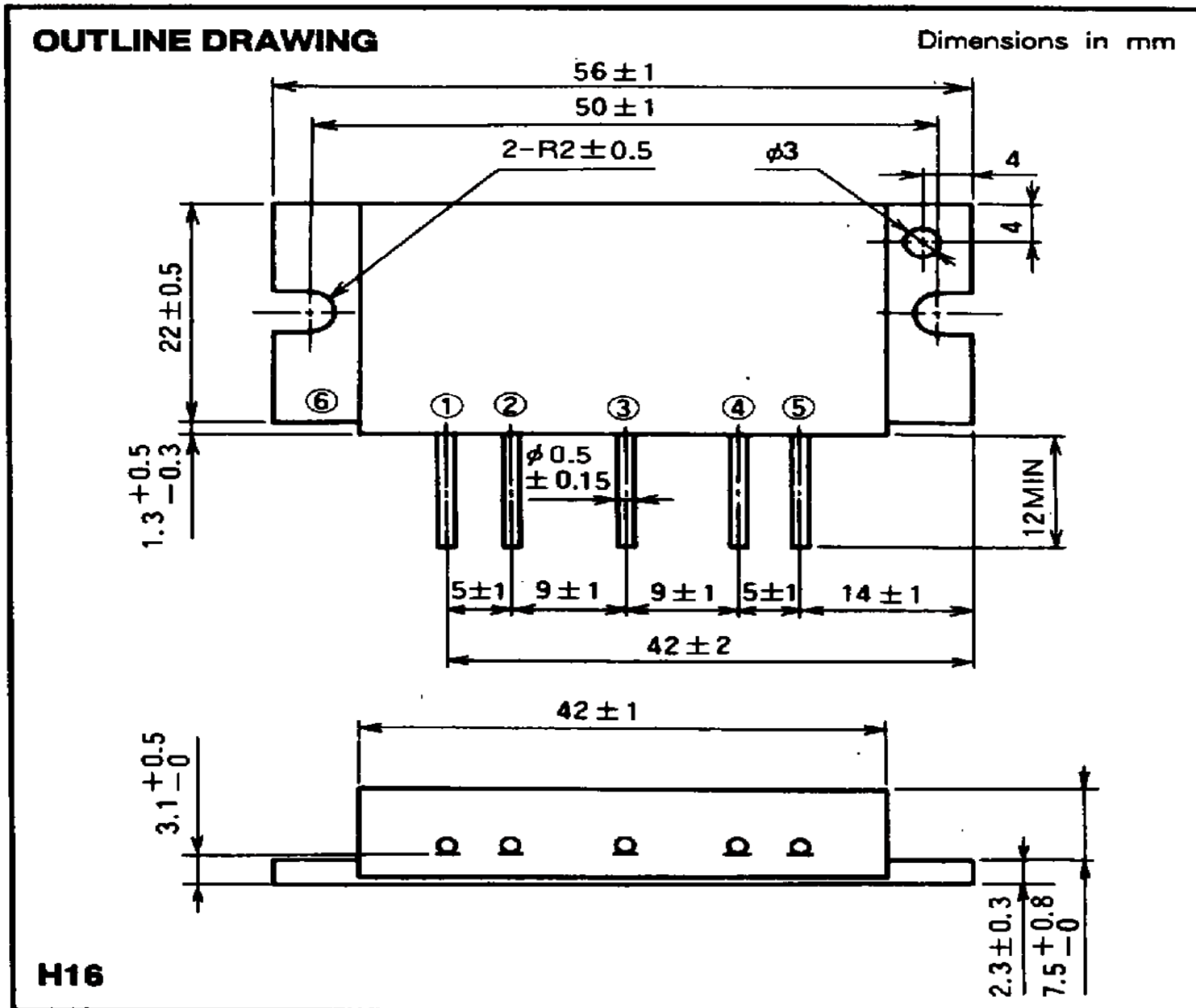

- PIN :
- ① Pin : RF INPUT
 - ② Vcc1 : 1st. DC SUPPLY
 - ③ Vbb : BASE BIAS SUPPLY
 - ④ Vcc2 : 2nd. DC SUPPLY
 - ⑤ Po : RF OUTPUT
 - ⑥ GND : FIN

ABSOLUTE MAXIMUM RATINGS (Tc = 25 °C unless otherwise noted)

Symbol	Parameter	Conditions	Ratings	Unit
Vcc	Supply voltage	Vbb ≤ 5V	16	V
Vbb	Base bias	Vcc ≤ 12.5V	6	V
Icc	Total current		5	A
Pin(max)	Input power	ZG = ZL = 50 Ω	20	mW
PO(max)	Output power	ZG = ZL = 50 Ω	20	W
Tc(OP)	Operation case temperature		- 30 to 110	°C
Tstg	Storage temperature		- 40 to 110	°C

Note. Above parameters are guaranteed independently.

ELECTRICAL CHARACTERISTICS (Tc = 25 °C unless otherwise noted)

Symbol	Parameter	Test conditions	Limits		Unit
			Min	Max	
f	Frequency range	Pin = 10mW Vcc1, 2 = 12.5V Vbb = 5V ZG = ZL = 50 Ω	430	470	MHz
Po	Output power		13		W
ηT	Total efficiency		35		%
2fo	2nd. harmonic			- 30	dBc
3fo	3rd. harmonic			- 35	dBc
ρin	Input VSWR			2.8	-
-	Load VSWR tolerance	Vcc1 = 12.5V, Vcc2 = 15.2V, Vbb = 5V Po = 13W (Pin : controlled) Load VSWR = 20:1 (All phase), 2sec. ZG = 50Ω	No degradation or destroy		-

Note. Above parameters, ratings, limits and conditions are subject to change.