

# M67745

846-903MHz, 12.5V, 7W, FM MOBILE RADIO

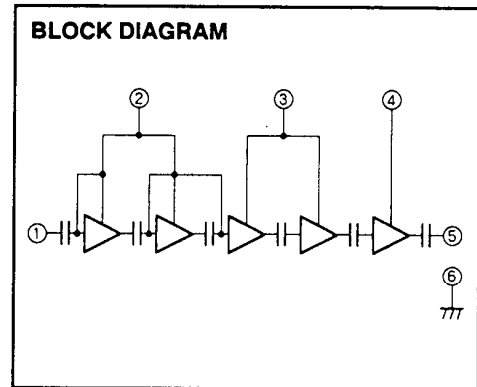
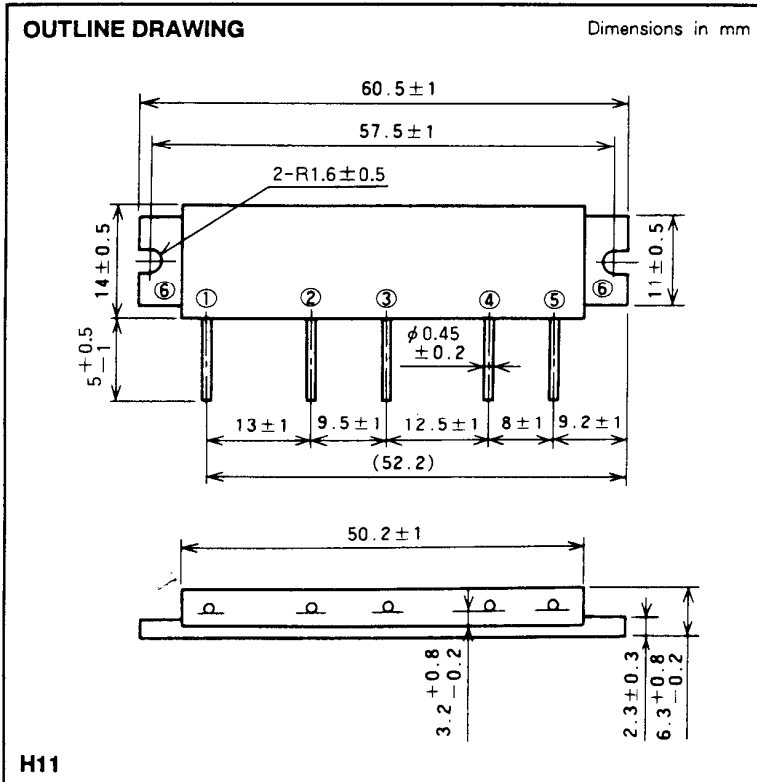

PIN :  
 ① Pin : RF INPUT  
 ② Vcc1 : 1st. DC SUPPLY  
 ③ Vcc2 : 2nd. DC SUPPLY  
 ④ Vcc3 : 3rd. DC SUPPLY  
 ⑤ Po : RF OUTPUT  
 ⑥ GND : FIN

**ABSOLUTE MAXIMUM RATINGS** (T<sub>c</sub> = 25°C unless otherwise noted)

Symbol	Parameter	Conditions	Ratings	Unit
V <sub>cc1,2</sub>	Supply voltage		9	V
V <sub>cc3</sub>			17	V
I <sub>cc</sub>	Total current		4	A
P <sub>in(max)</sub>	Input power	f=846-903MHz, V <sub>cc1</sub> ≤ 8V, Z <sub>G</sub> =Z <sub>L</sub> =50Ω	7	mW
P <sub>O(max)</sub>	Output power	Ditto	10	W
T <sub>c(OP)</sub>	Operation case temperature		- 30 to 110	°C
T <sub>stg</sub>	Storage temperature		- 40 to 110	°C

Note. Above parameters are guaranteed independently.

**ELECTRICAL CHARACTERISTICS** (T<sub>c</sub> = 25°C unless otherwise noted)

Symbol	Parameter	Test conditions	Limits		Unit
			Min	Max	
f	Frequency range	V <sub>cc1</sub> = V <sub>cc2</sub> = 8V V <sub>cc3</sub> = 12.5V P <sub>in</sub> = 2mW Z <sub>G</sub> = Z <sub>L</sub> = 50Ω	846	903	MHz
P <sub>O</sub>	Output power		7		W
η <sub>T</sub>	Total efficiency		35		%
2f <sub>o</sub>	2nd. harmonic			- 30	dBc
ρ <sub>in</sub>	Input VSWR			2.8	-
-	Load VSWR tolerance	V <sub>cc1</sub> = 8V, V <sub>cc3</sub> = 15.2V P <sub>O</sub> = 7W (V <sub>cc2</sub> : controlled) P <sub>in</sub> = 2mW Load VSWR=20:1 (All phase), 5sec.	No degradation or destroy		-

Note. Above parameters, ratings, limits and conditions are subject to change.

TYPICAL PERFORMANCE DATA

TOTAL EFFICIENCY, OUTPUT POWER, EACH CURRENT VS. FREQUENCY CHARACTERISTICS

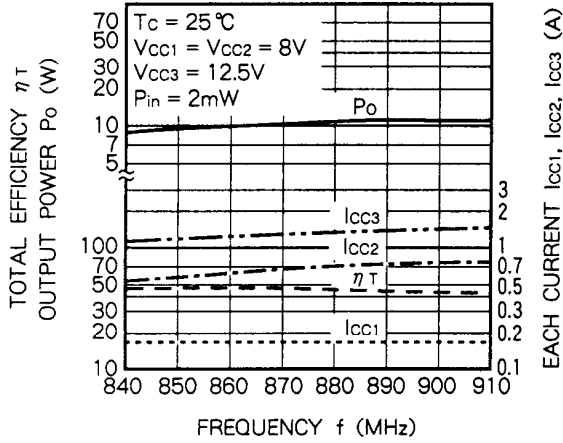

OUTPUT POWER, EACH CURRENT VS. 2nd VOLTAGE CHARACTERISTICS

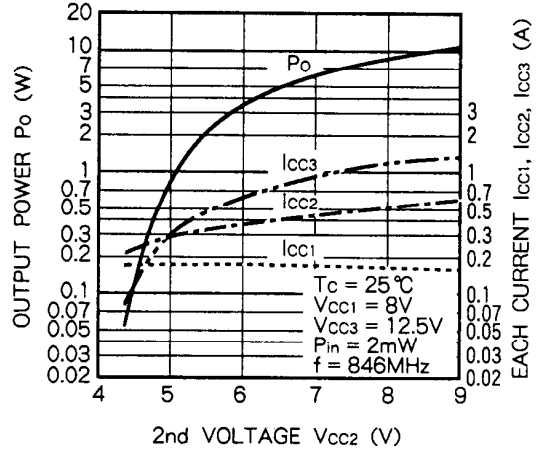

OUTPUT POWER, EACH CURRENT VS. 2nd VOLTAGE CHARACTERISTICS

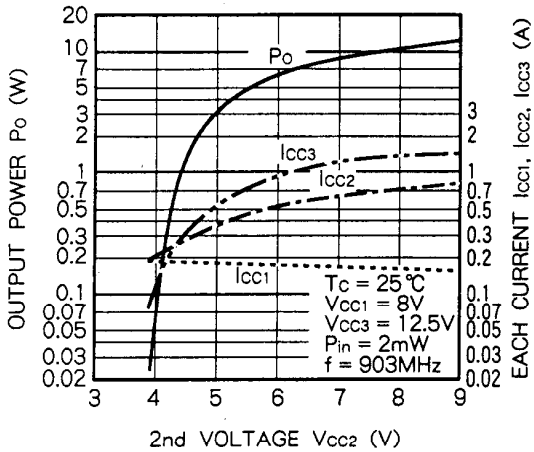

OUTPUT POWER, EACH CURRENT VS. INPUT POWER CHARACTERISTICS

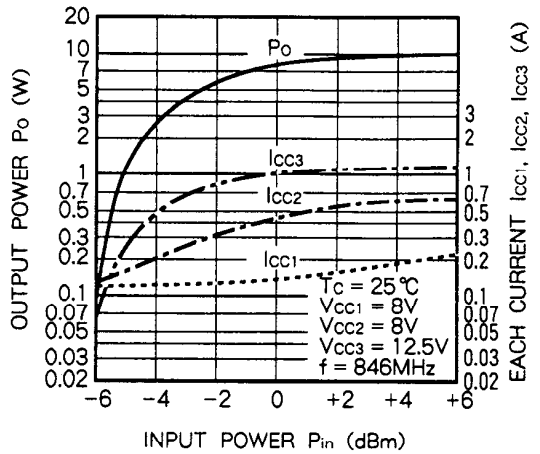

OUTPUT POWER, EACH CURRENT VS. INPUT POWER CHARACTERISTICS

