

# M67749UH

470-490MHz, 12.5V, 7W, FM PORTABLE RADIO

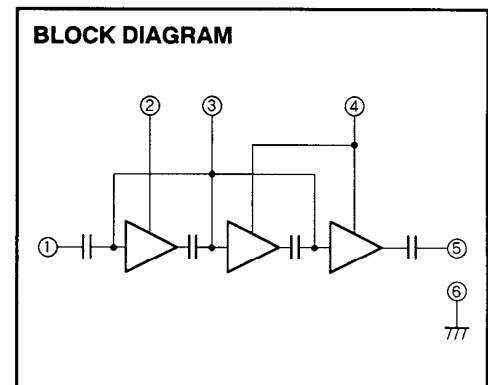
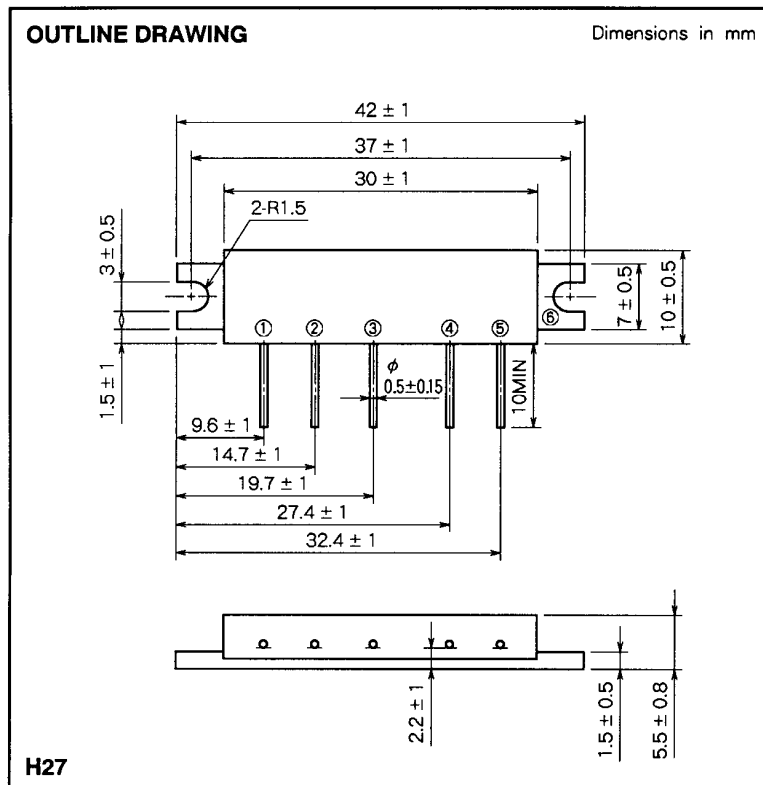

- PIN :
- ① Pin : RF INPUT
  - ② Vcc1 : 1st. DC SUPPLY
  - ③ VBB : BASE BIAS SUPPLY
  - ④ Vcc2 : 2nd. DC SUPPLY
  - ⑤ Po : RF OUTPUT
  - ⑥ GND : FIN

**ABSOLUTE MAXIMUM RATINGS** (T<sub>c</sub> = 25°C unless otherwise noted)

Symbol	Parameter	Conditions	Ratings	Unit
V <sub>CC</sub>	Supply voltage	V <sub>BB</sub> ≤ 5V	15	V
V <sub>BB</sub>	Base bias	V <sub>CC</sub> ≤ 12.5V	5.5	V
I <sub>CC</sub>	Total current	Z <sub>G</sub> = Z <sub>L</sub> = 50 Ω	4	A
P <sub>in(max)</sub>	Input power	f=470-490MHz, V <sub>CC1</sub> ≤ 12.5V, Z <sub>G</sub> =Z <sub>L</sub> =50 Ω	40	mW
P <sub>O(max)</sub>	Output power	f=470-490MHz, V <sub>CC1</sub> ≤ 12.5V, Z <sub>G</sub> =Z <sub>L</sub> =50 Ω	10	W
T <sub>C(OP)</sub>	Operation case temperature	Z <sub>G</sub> = Z <sub>L</sub> = 50 Ω	- 30 to 110	°C
T <sub>stg</sub>	Storage temperature		- 40 to 110	°C

Note. Above parameters are guaranteed independently.

**ELECTRICAL CHARACTERISTICS** (T<sub>c</sub> = 25°C unless otherwise noted)

Symbol	Parameter	Test conditions	Limits		Unit
			Min	Max	
f	Frequency range	V <sub>CC</sub> = 12.5V V <sub>BB</sub> = 5V P <sub>in</sub> = 20mW Z <sub>G</sub> = Z <sub>L</sub> = 50 Ω	470	490	MHz
P <sub>O</sub>	Output power		7		W
η <sub>T</sub>	Total efficiency		35		%
2f <sub>o</sub>	2nd. harmonic		- 25		dBc
3f <sub>o</sub>	3rd. harmonic		- 30		dBc
ρ <sub>in</sub>	Input VSWR		2.5	-	
-	Load VSWR tolerance	V <sub>CC2</sub> = 13.2V, V <sub>BB</sub> = 5V, P <sub>in</sub> = 20mW P <sub>O</sub> = 7W (V <sub>CC1</sub> : controlled) Load VSWR=20:1(All phase), 2sec. Z <sub>G</sub> = 50Ω	No degradation or destroy		-

Note. Above parameters, ratings, limits and conditions are subject to change.