

M67796

1240-1300MHz, 7.2V, 1.4W, FM PORTABLE RADIO

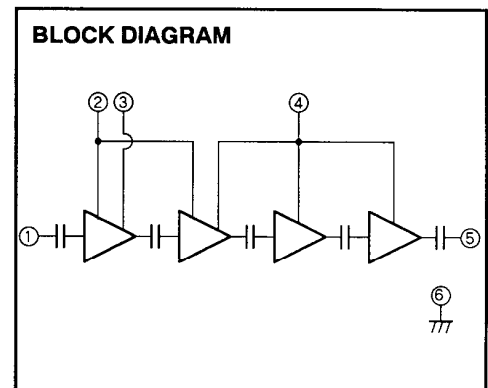
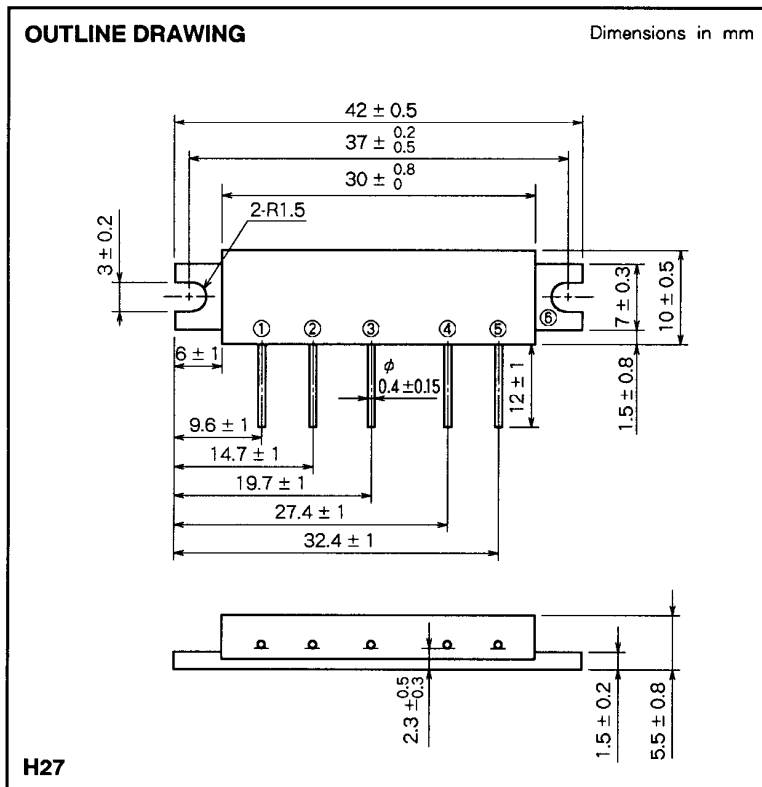

- PIN :
- ① Pin : RF INPUT
 - ② VBB : BASE BIAS SUPPLY
 - ③ VCC1 : 1st. DC SUPPLY
 - ④ VCC2 : 2nd. DC SUPPLY
 - ⑤ Po : RF OUTPUT
 - ⑥ GND : FIN

ABSOLUTE MAXIMUM RATINGS (T_c = 25 °C unless otherwise noted)

Symbol	Parameter	Conditions	Ratings	Unit
V _{CC1}	1st. DC supply		6	V
V _{CC2}	2nd. DC supply		15	V
V _{BB}	Base bias		6	V
I _{CC}	Total current		3	A
P _{in(max)}	Input power	V _{CC1} ≤ 5V, V _{BB} = 5V, Z _G = Z _L = 50Ω	20	mW
P _{o(max)}	Output power	Z _G = Z _L = 50Ω	2.5	W
T _{C(OP)}	Operation case temperature		- 30 to 100	°C
T _{stg}	Storage temperature		- 40 to 100	°C

Note. Above parameters are guaranteed independently.

ELECTRICAL CHARACTERISTICS (T_c = 25 °C unless otherwise noted)

Symbol	Parameter	Test conditions	Limits		Unit
			Min	Max	
f	Frequency range	V _{CC1} = 5V	1.24	1.3	GHz
P _o	Output power	V _{BB} = 5V	1.4		W
η _T	Total efficiency	V _{CC2} = 7.2V	25		%
2f _o	2nd. harmonic	P _{in} = 10mW		- 28	dBc
ρ _{in}	Input VSWR	Z _G = Z _L = 50Ω		3.5	-
-	Load VSWR tolerance	V _{BB} = 5V, V _{CC2} = 15V, P _{in} = 10mW P _o = 1.4W (V _{CC1} : controlled), Load VSWR = 10:1 (All phase), 5sec. Z _G = 50Ω	No degradation or destroy		-

Note. Above parameters, ratings, limits and conditions are subject to change.