

M68707L

215-230MHz, 9.6V, 7W, FM PORTABLE RADIO

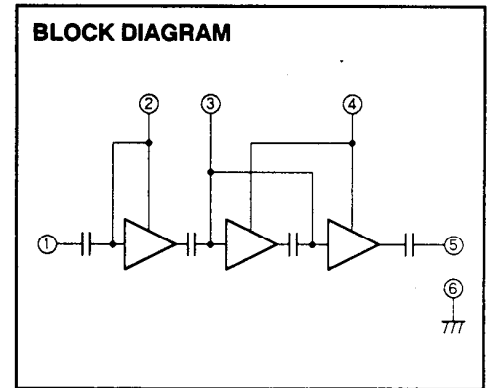
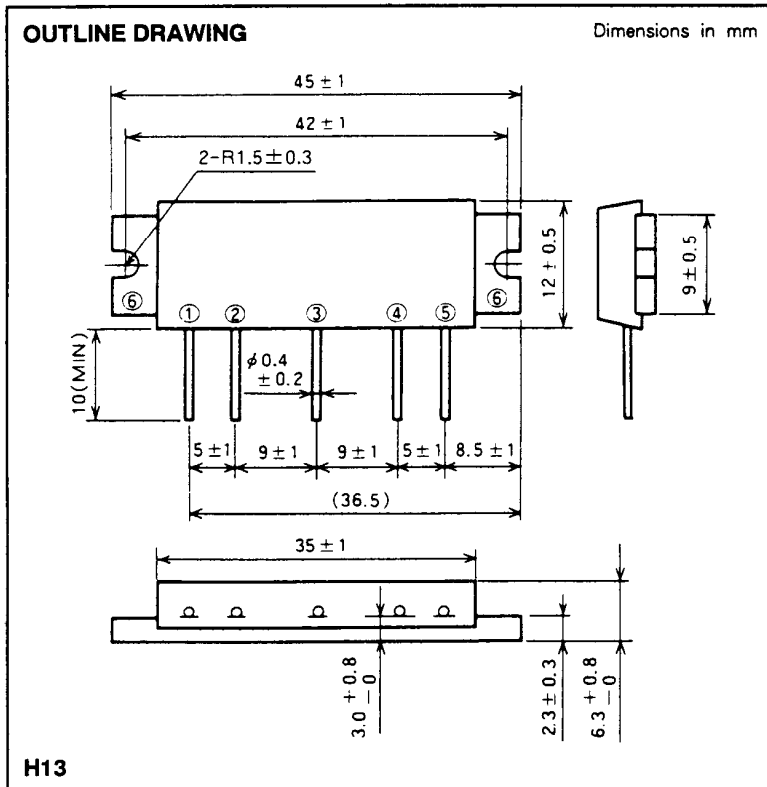

- PIN :
- ① Pin : RF INPUT
 - ② Vcc1 : 1st. DC SUPPLY
 - ③ Vbb : BASE BIAS SUPPLY
 - ④ Vcc2 : 2nd. DC SUPPLY
 - ⑤ Po : RF OUTPUT
 - ⑥ GND : FIN

ABSOLUTE MAXIMUM RATINGS (T_c = 25 °C unless otherwise noted)

Symbol	Parameter	Conditions	Ratings	Unit
V _{cc}	Supply voltage	V _{bb} = 5V	13	V
V _{bb}	Base bias	V _{cc} ≤ 9.6V, Z _G = Z _L = 50 Ω	6	V
I _{cc}	Total current		4	A
P _{in(max)}	Input power	V _{cc1} ≤ 9.6V, V _{bb} = 5V, Z _G = Z _L = 50 Ω	40	mW
P _{o(max)}	Output power	Z _G = Z _L = 50 Ω	10	W
T _{c(OP)}	Operation case temperature	Z _G = Z _L = 50 Ω	- 30 to 110	°C
T _{stg}	Storage temperature		- 40 to 110	°C

Note. Above parameters are guaranteed independently.

ELECTRICAL CHARACTERISTICS (T_c = 25 °C unless otherwise noted)

Symbol	Parameter	Test conditions	Limits		Unit
			Min	Max	
f	Frequency range	V _{cc} = 9.6V V _{bb} = 5V P _{in} = 20mW Z _G = Z _L = 50 Ω	215	230	MHz
P _o	Output power		7		W
η _T	Total efficiency		40		%
2f _o	2nd. harmonic			- 25	dBc
3f _o	3rd. harmonic			- 30	dBc
ρ _{in}	Input VSWR			2.5	-
-	Load VSWR tolerance	V _{cc} = 9.6V, V _{bb} = 5V P _o = 7W (P _{in} : controlled) Load VSWR=20:1 (All phase) Z _G = 50Ω	No degradation or destroy		-

Note. Above parameters, ratings, limits and conditions are subject to change.