

M68721

118-137MHz, 12.5V, 10W AM PORTABLE RADIO

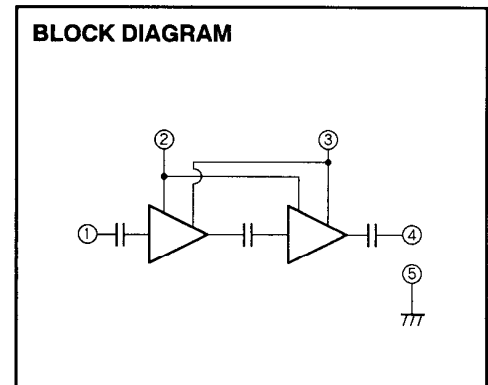
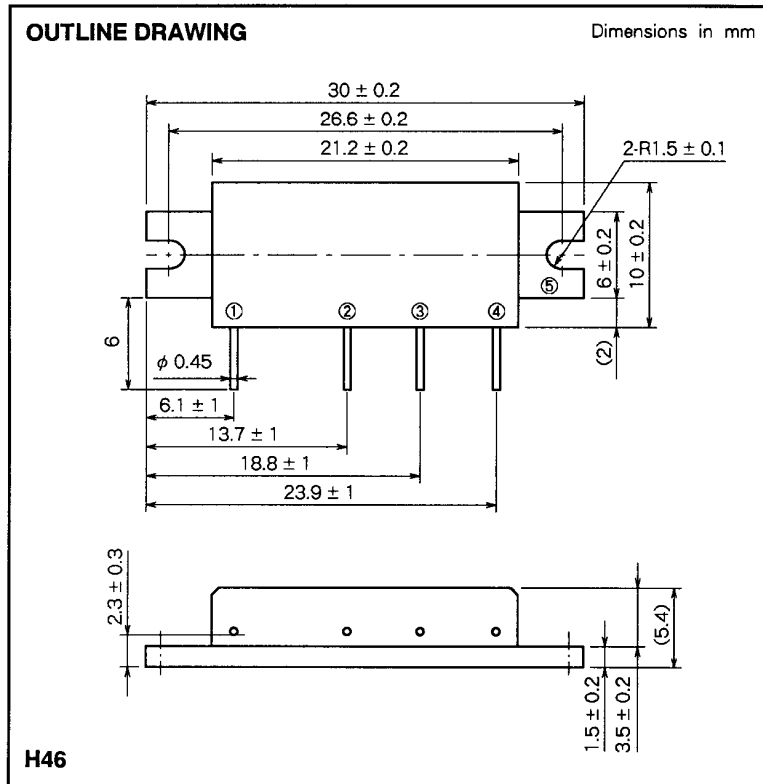

PIN :

- ① Pin : RF INPUT
- ② V_{GG} : GATE BIAS SUPPLY
- ③ V_{DD} : DRAIN BIAS SUPPLY
- ④ P_o : RF OUTPUT
- ⑤ GND : FIN

ABSOLUTE MAXIMUM RATINGS (T_c = 25°C unless otherwise noted)

Symbol	Parameter	Conditions	Ratings	Unit
V _{DD}	Supply voltage	V _{GG} ≤ 3.5V, Z _G = Z _L = 50Ω	16	V
V _{GG}	Gate bias voltage		4	V
P _{in}	Input power	f = 118 to 137MHz, Z _G = Z _L = 50Ω	40	mW
P _o	Output power	f = 118 to 137MHz, V _{DD} ≤ 9V, Z _G = Z _L = 50Ω	12	W
T _{C(OP)}	Operation case temperature	f = 118 to 137MHz, V _{DD} ≤ 9V, Z _G = Z _L = 50Ω	- 30 to 100	°C
T _{stg}	Storage temperature		- 40 to 110	°C

Note : Above parameters are guaranteed independently.

ELECTRICAL CHARACTERISTICS (T_c = 25°C, Z_G = Z_L = 50Ω, unless otherwise noted)

Symbol	Parameter	Test conditions	Limits		Unit
			Min	Max	
f	Frequency range		118	137	MHz
P _o	Output power		10		W
η _T	Total efficiency	V _{DD} = 12.5V	40		%
2f _o	2nd. harmonic	V _{GG} = 3.5V		- 20	dBc
3f _o	3rd. harmonic	P _{in} = 20mW		- 30	dBc
ρ _{in}	Input VSWR			2.8	-
-	Stability	Z _G = 50Ω, V _{DD} = 10 to 15V, Load VSWR < 4 : 1	No parasitic oscillation		-
-	Load VSWR tolerance	V _{DD} = 15V, V _{GG} = 3.5V, P _o = 10W(P _{in} Adjust), Z _L = 20 : 1	No degradation or destroy		-

Note : Above parameters, ratings, limits and conditions are subject to change.