

PRELIMINARY DATA

23-STAGE COUNTER

- LOW QUIESCENT POWER DISSIPATION
- WIDE SUPPLY VOLTAGE RANGE: 3 to 17V
- FULLY PROTECTED INPUTS
- INVERTER AVAILABILITY FOR CRYSTAL OSCILLATOR TIMING APPLICATION
- ADJUSTABLE FREQUENCY DIVIDER IN 127 STEPS
- TEST OUTPUT AVAILABLE
- MOTOR DRIVE STAGE OUTPUT

The M730 (standard temperature range) is a 23 stage binary counter in COS/MOS technology in a single monolithic chip. An inverter is available for crystal oscillator application in which the function of the trimmer capacitor has been taken over by the variable frequency divider comprised in the IC and used to set the correct output frequency. For this purpose, seven adjustment terminals are provided on the M730: they are used to set the divider ratio to the required value with an accuracy of 10^{-6} . The adjustable frequency divider has been designed in such a way that the maximum output frequency is set when all adjustment terminals are either open-circuit or connected to pin 14. If one or more adjustment terminals are grounded (taken to pin 13), the output frequency decreases. The by-four-divided oscillator frequency may be checked at a separate test output (pin 8) non-reactive with respect to the oscillator. Based on this check the output frequency and consequently the accuracy of the clock may be adjusted at the terminal 1 to 7 by means of the variable frequency divider. With an oscillator frequency of 4.194812 MHz, the series-connected push-pull output stage supplies a symmetrical square wave signal with a pulse duty factor of 0.5 and a repetition frequency of 0.5 Hz if the variable frequency divider is set to its medium value. The device is available in 14 lead dual in-line plastic or ceramic package.

ABSOLUTE MAXIMUM RATINGS*

V_{DD} **	Supply voltage	-0.3 to +17	V
I_{11}	Output current	60	mA
P_{tot}	Power dissipation at $T_{amb} = 25^{\circ}\text{C}$	200	mW
T_{op}	Operating temperature range	-40 to +85	$^{\circ}\text{C}$
T_{stg}	Storage temperature range	-55 to +125	$^{\circ}\text{C}$

* Stresses above those listed under "Absolute Maximum Ratings" may cause permanent damage to the device. This is a stress rating only and functional operation of the device at these or any other condition above those indicate in the "Recommended operating conditions" section of this specification is not implied. Exposure to absolute maximum rating conditions for extended periods may affect device reliability.

** All voltages are with respect to V_{SS} (GND).

ORDERING NUMBERS: M730 B1 for dual in-line plastic package
M730 D1 for dual in-line ceramic package frit seal

M 730

© 1994 Analog Devices, Inc.

MECHANICAL DATA (dimensions in mm)

Dual in-line ceramic package frit seal

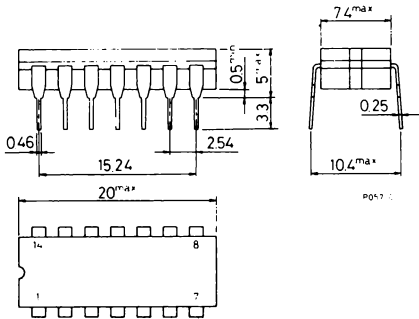

Dual in-line plastic package

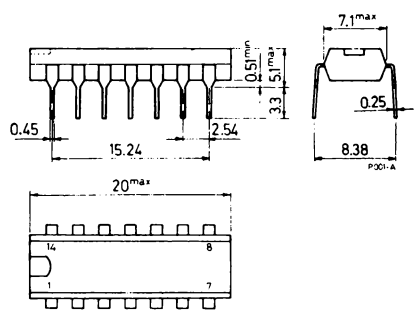

PIN CONNECTIONS

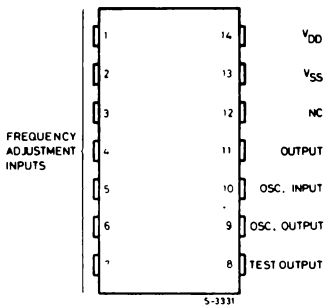

BLOCK DIAGRAM and OUTPUT WAVEFORM

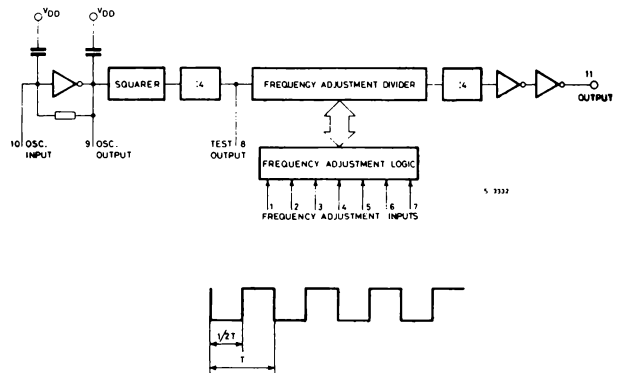

RECOMMENDED OPERATING CONDITIONS

V_{DD}	Supply voltage: for general applications for oscillator starting	3 to 16.5	V
V_i	Input voltage	6 to 16.5	V
I_{11}	Output current	V_{DD} to V_{SS}	V
T_{op}	Operating temperature	40	mA
		-40 to +85	°C

© 1994 Analog Devices, Inc.

STATIC ELECTRICAL CHARACTERISTICS (over recommended operating conditions)

Parameter	Test conditions		Values									Unit
			-40°C			25°C			85°C			
			V _O (V)	V _{DD} (V)	Min.	Typ.	Max.	Min.	Typ.	Max.	Min.	
V _{OH} Output high voltage	I _{OH} = 0	6	5.99			5.99	6		5.95			V
		12	11.99			11.99	12		11.95			
V _{OL} Output low voltage	I _{OL} = 0	6			0.01		0	0.01			0.05	V
		12			0.01		0	0.01			0.05	
I _{DN} Output drive current N-channel		2	6	21			20	25		13		mA
		2	12	34			33	40		22		
I _{DP} Output drive current P-channel		4	6	21			20	25		13		mA
		10	12	34			33	40		22		
I _{ON} Current consump.	I _O = 0*		12				3					mA

* At quartz frequency of 4.194.812 Hz.

DYNAMIC ELECTRICAL CHARACTERISTICS (T_{amb} = 25°C, quartz frequency 4.194.812 Hz)

Parameter	Test conditions		Values						Unit	
			V _{DD} (V)	M730 D1 type			M730 B1 type			
				Min.	Typ.	Max.	Min.	Typ.		Max.
f _T Frequency test output		12	1.048703			1.048703			Hz	
f _o ** Output frequency		12		0.5			0.5		Hz	
$\frac{\Delta f_o}{f_o}$ Range output frequency adjustment		12		± 121			± 121		ppm	
R _O Output resistance	R _L = 300Ω	12			100			100	Ω	

** At the centre position of the variable divider.

M 730

APPLICATION CIRCUIT

