



**PHOTOELECTRIC SMOKE DETECTOR  
WITH INTERCONNECT**

**GENERAL DESCRIPTION**

The M75310 is a very low-power IC providing all of the required features for a photoelectric type smoke detector. This device can be used in conjunction with an infrared photoelectric chamber to sense scattered light from smoke particles.

A variable-gain photo amplifier can be directly interfaced to an infrared emitter / detector pair. The amplifier gain levels are Determined by two external capacitors that are then internally selected depending on the operating mode. Low gain is selected during standby and timer modes. During a local alarm this low gain is increased (internally) by ~ 10% to reduce false triggering. High gain is used during the push-button test and during standby to periodically monitor the chamber sensitivity.

**FEATURES**

- Interconnect up to 50 detectors.
- Piezoelectric horn driver.
- Power-on reset.
- Built-in circuits to reduce false triggering.
- 6V to 12V operating voltage range.
- Average Supply Current : 8  $\mu$  A
- ESD-Protection circuitry on all pins.
- Temporal horn pattern.

**APPLICATIONS**

- Smoke detector.

**PIN ASSIGNMENT**

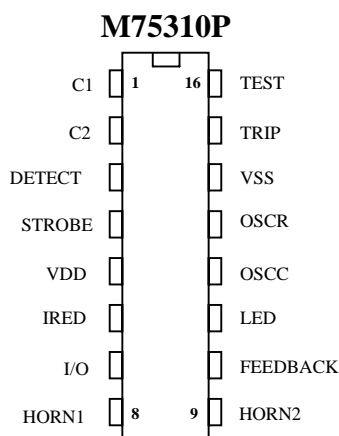



**PHOTOELECTRIC SMOKE DETECTOR  
WITH INTERCONNECT**

**PIN AND CIRCUIT DESCRIPTION**

Pin No	Pin Name	Description
1	C1	A capacitor connected to this pin determines the gain of the photo amplifier during the push-to-test mode and during the chamber monitor test. A typical value for this high-gain mode is $0.047 \mu\text{F}$ but should be selected based on the photo chamber background reflections reaching the detector and the desired level of sensitivity. $A_e \cong 1 + (C1 / 10)$ where C1 is in pF. $A_e$ should not exceed 10,000.
2	C2	A capacitor connected to this pin determines the gain of the photo amplifier during standby. A typical value for this low-gain mode is 4700 pF but should be selected based on a specific photo chamber and the desired level of sensitivity to smoke. $A_e \cong 1 + (C2 / 10)$ where C2 is in pF. $A_e$ should not exceed 10,000.
3	DETECT	This is the input to the photo amplifier and is connected to the cathode of the photo diode. The photo diode is operated at zero bias and should have low dark leakage current and low capacitance.
4	STROBE	This output provides a strobed, regulated voltage of VDD-5V. The minus side of all internal and external photo amplifier circuitry is referenced to this pin.
5	VDD	This pin is connected to the most-positive supply potential.
6	IREDD	This output provides a pulsed base current for the external NPN transistor, which drives the IR emitter. Its beta should be greater than 100. The IREDD output is not active, to minimize noise impact, when the horn and visible LED outputs are active.
7	I/O	A connection at this pin allows multiple smoke detectors to be interconnected. If a local smoke condition occurs, this pin is driven high. As an input, this pin is sampled nominally every 1.35 seconds during standby. Any local-alarm condition causes this pin to be ignored as an input. An internal NMOS device acts as a charge dump to aid in applications involving a large (distributed) capacitance. The charge dump is activated at the end of local or test alarm. This pin also has an on-chip pull-down resistor and must be left unconnected if not used. In application, there is a series current-limiting resistor to other smoke alarms.
8	HORN1	These three pins are used in conjunction with external passive components and a self-resonating piezoelectric transducer. HORN1 is connected to the piezo metal support electrode; the complementary output, HORN2, is connected to the ceramic electrode and the FEEDBACK input to the feedback electrode. A continuous modulated tone indicates either a local or remote alarm condition. A short (10ms) chirp indicates a low-battery chirp occurs almost simultaneous with the visible LED flash. If the FEEDBACK pin is not used, it must be connected to VDD or VSS.
9	HORN2	
10	FEEDBACK	
11	LED	This open-drain NMOS output is used to directly drive a visible LED. The low-battery test does not occur coincident with any other test or alarm signal. The LED also indicates detector status as follows (with component values as in the typical application, all times nominal) : <b>Standby</b> — Pulses every 43 seconds. <b>Local Smoke</b> — Pulses every 0.67 seconds. <b>Remote Alarm</b> — No pulses. <b>Test Mode</b> — Pulses every 0.67 seconds.
12	OSCC	A capacitor between this pin and VDD, along with a parallel resistor, forms part of a two-terminal oscillator and sets the internal clock low time. With component values as shown, this nominal time is 11 ms and essentially the oscillator period.
13	OSCR	A resistor between this pin and OSCC (pin 12) is part of the two-terminal oscillator and sets the internal clock high time, which is also the $I_{RED}$ pulse width. With component values as shown, this nominal time is $105 \mu\text{s}$ .
14	VSS	This pin is connected to the most negative supply potential (usually ground).
15	TRIP	This pin is connected to an external voltage, which determines the low-supply alarm threshold. The trip voltage is obtained through a resistor divider connected between the VDD and LED pins. The low-supply alarm threshold voltage ( in volts ) $\cong (5R15/R14) + 5$ where R15 and R14 are in the same units.
16	TEST	This pin has an internal pull-down device and is used to manually invoke a test mode. The Push-to-Test Mode is initiated by a high logic level on this pin (usually the depression of a normally open push-button switch to VDD). After one oscillator cycle, $I_{RED}$ pulse every 336 ms (nominal) and amplifier gain is increased by internal selection of C1. Background reflections in the smoke chamber can be used to simulate a smoke condition. After the third $I_{RED}$ pulse, a successful test (three consecutive simulated smoke conditions) activates the horn drivers and the I/O pin. When the push-button is released, the input returns to VSS due to the internal pull down. After one oscillator cycle, the amplifier gain returns to normal and after three additional $I_{RED}$ pulse (less than one second), the device exits this mode and returns to standby.



PHOTOELECTRIC SMOKE DETECTOR  
WITH INTERCONNECT

FUNCTIONAL BLOCK DIAGRAM

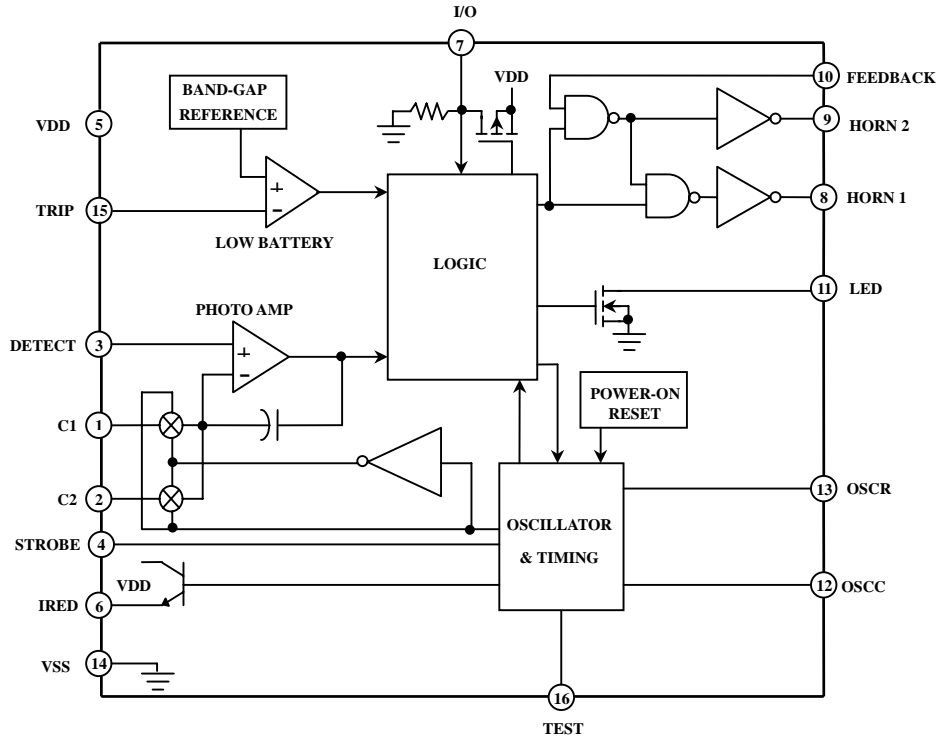

LOCAL ALARM TIMING DIAGRAM ( NOT TO SCALE ) :

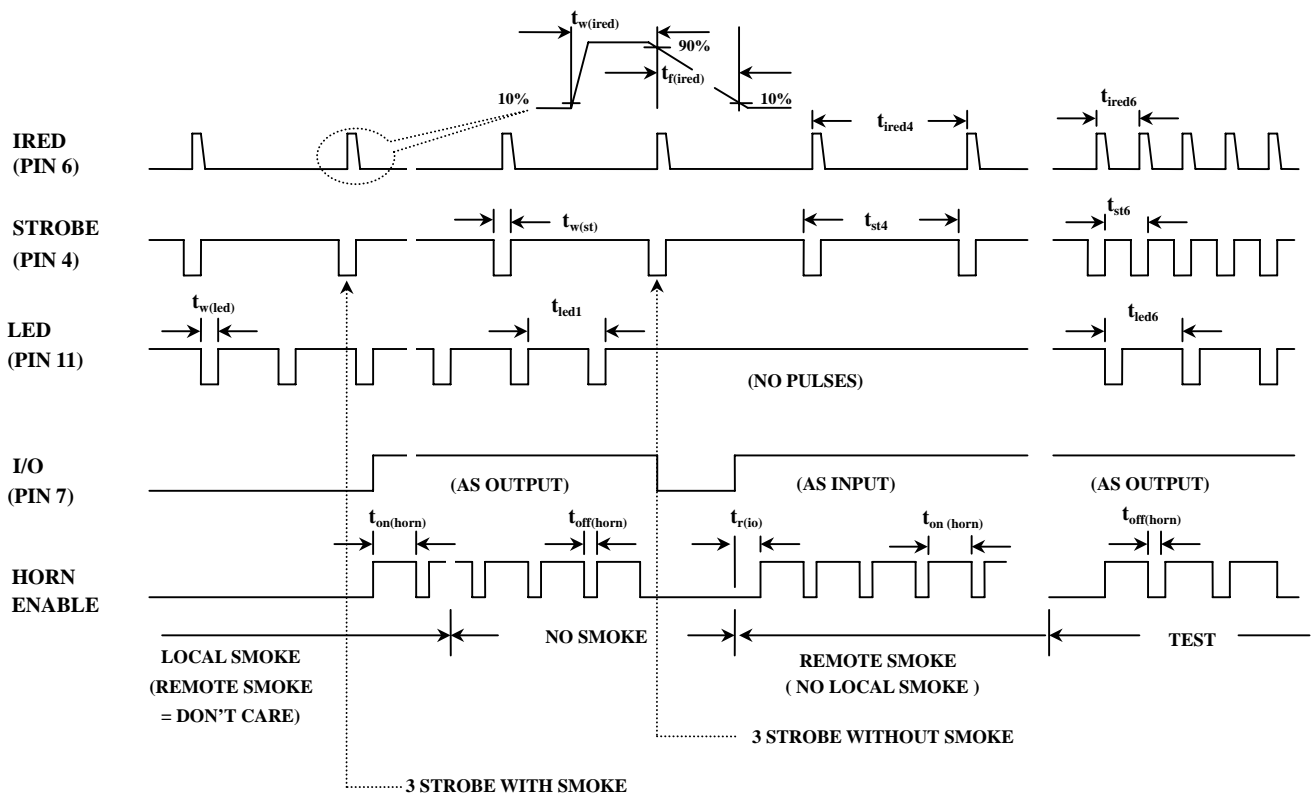



PHOTOELECTRIC SMOKE DETECTOR  
WITH INTERCONNECT

STANDBY TIMING DIAGRAM ( NOT TO SCALE ) :

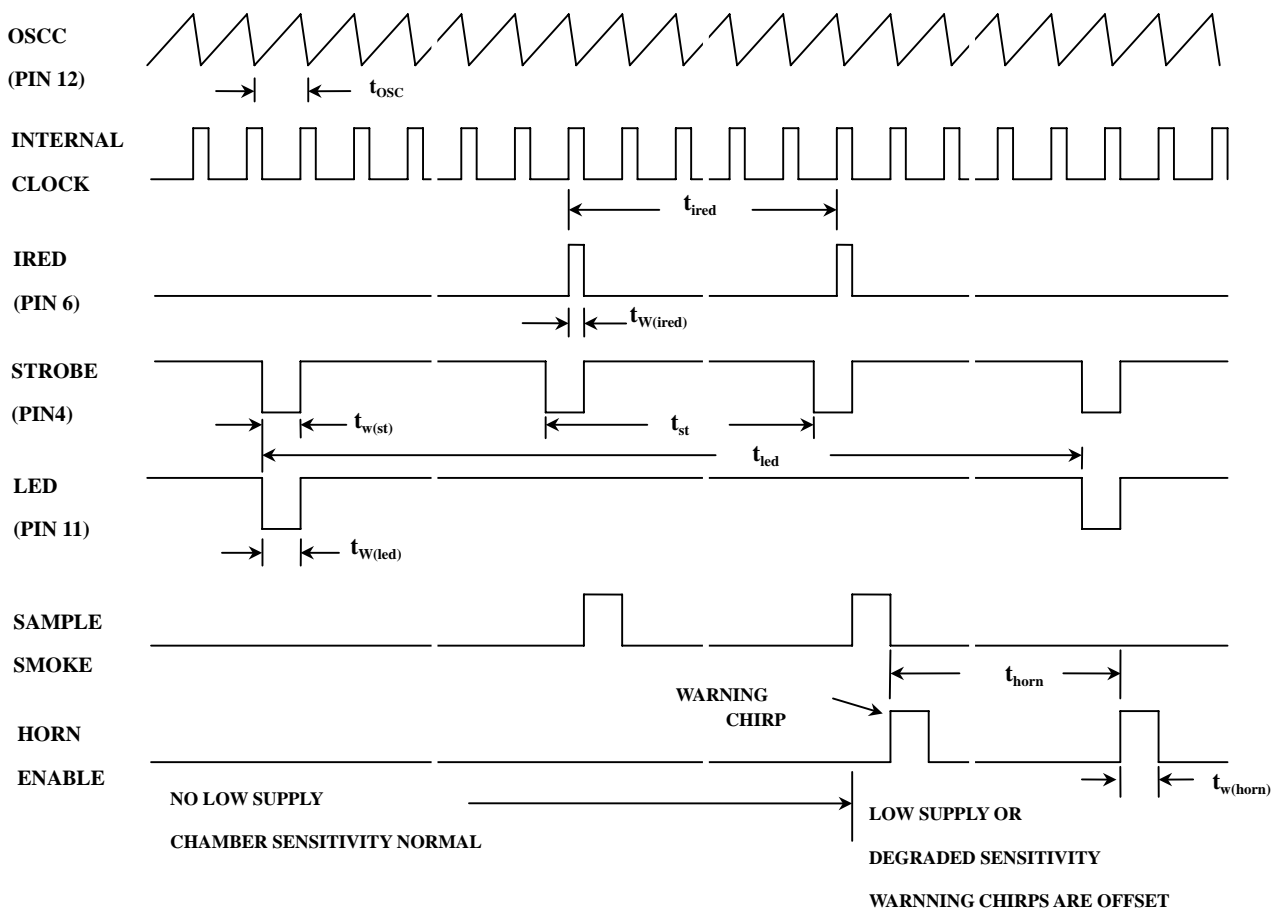



**PHOTOELECTRIC SMOKE DETECTOR  
WITH INTERCONNECT**

**ABSOLUTE MAXIMUM RATING**

Parameter	Sym.	Rating	Unit
Supply Voltage Range	$V_{DD}$	-0.5 ~ 13	V
Input Voltage Range	$V_{IN}$	-0.3 to $V_{DD} + 0.3$	V
Input Current	$I_{IN}$	10	mA
Operating Temperature Range	$T_A$	-25 ~ 75	°C
Storage Temperature Range	$T_S$	-55 to 125	°C

**DC ELECTRICAL CHARACTERISTICS**

( $T_A = -25^\circ\text{C} \sim 75^\circ\text{C}$ )

Characteristics	Sym.	Pin	$V_{DD}$	Min.	Typ.	Max.	Unit	Conditions	
Supply Voltage	$V_{DD}$		—	6.0	—	12	V		
Operating Supply Current	$I_{DD}$		12	—	—	8	$\mu\text{A}$	Average Standby	
			12	—	—	2.0	mA	During Strobe ON, $I_{RED}$ OFF	
			12	—	—	3.0	mA	During Strobe ON, $I_{RED}$ ON	
Low-Level Input Voltage	$V_{IL}$		7	9	—	—	1.5	V	
			10	9	—	—	2.7	V	
			16	9	—	—	7.0	V	
			15	9	—	—	0.5	V	
High-Level Input Voltage	$V_{IH}$		7	9	3.2	—	—	V	
			10	9	6.3	—	—	V	
			16	9	8.5	—	—	V	
			15	9	1.6	—	—	V	
Input Leakage High	$I_{IH}$		12	12	—	—	100	nA	$V_{IN} = V_{DD}$ , Strobe Active, Pin12 @ $V_{DD}$
			15	12	—	—	100	nA	$V_{IN} = V_{DD}$
Input Leakage Low	$I_{IL}$		12	12	—	—	-100	nA	$V_{IN} = V_{ST}$ , Strobe Active, Pin12 @ $V_{DD}$
			15	12	—	—	-100	nA	$V_{IN} = V_{SS}$
			16	12	—	—	-1.0	$\mu\text{A}$	
Input Pull-Down Current	$I_{IN}$		16	9	0.5	—	10	$\mu\text{A}$	$V_{IN} = V_{DD}$ (@ $V_{DD} = 9\text{V}$ )
			7	9	20	—	80	$\mu\text{A}$	No Local Smoke, $V_{IN} = V_{DD}$ (@ $V_{DD} = 9\text{V}$ )
			7	12	—	—	140	$\mu\text{A}$	No Local
Low-Level Output Voltage	$V_{OL}$		11	6.5	—	—	0.6	V	$I_O = 10\text{mA}$
			8, 9	6.5	—	—	1.0	V	$I_O = 16\text{mA}$
High-Level Output Voltage	$V_{OH}$	8, 9	6.5	5.5	—	—	V	$I_O = -16\text{mA}$	
Strobe Output Voltage	$V_{ST}$	4	12	$V_{DD} - 0.1$	—	—	V	Inactive, $I_O = -1\mu\text{A}$	
			9	$V_{DD} - 5.6$	—	$V_{DD} - 4.4$	V	Active, $I_O = 100\mu\text{A}$ to $500\mu\text{A}$	
Line Regulation	$\Delta V_{ST(\Delta V_{DD})}$		—	—	-60	—	dB	Active, $V_{DD} = 6\text{V}$ to $12\text{V}$	
$I_{RED}$ Output Voltage	$V_{IRED}$	6	12	—	—	0.1	V	Inactive, $I_O = 1\text{Ma}$ , $T_A = +25^\circ\text{C}$	
			9	2.25	3.0	3.75	V	Active, $I_O = -6\text{mA}$ , $T_A = +25^\circ\text{C}$	
Line Regulation	$\Delta V_{IRED(\Delta V_{DD})}$		—	—	-35	—	dB	Active, $V_{DD} = 6\text{V}$ to $12\text{V}$	
High-Level Output Voltage	$I_{OH}$	7	9	-4.0	—	—	mA	$V_{DD} = \text{Alarm}$ , I/O active, $V_O = V_{DD} - 2\text{V}$	
OFF Leakage Current High	$I_{OZ}$	11	12	—	—	1.0	$\mu\text{A}$	$V_O = V_{DD}$	
OFF Leakage Current Low	$I_{OZ}$	11	12	—	—	-1.0	$\mu\text{A}$	$V_O = V_{SS}$	
Low $V_{DD}$ Alarm Threshold	$V_{DD(th)}$		—	6.5	7.2	7.8	V		
Common Mode Voltage	$V_{IC}$	1, 2, 3	—	$V_{DD} - 4$	—	$V_{DD} - 2$	V	Any Alarm Condition	
Smoke Comparator Ref. Volt.	$V_{REF}$	Int.	—	$V_{DD} - 3.92$	—	$V_{DD} - 3.08$	V	Any Alarm Condition	



**PHOTOELECTRIC SMOKE DETECTOR  
WITH INTERCONNECT**

\* Limits over the operating temperature range are based on characterization data.

Characteristics are production tested at +25°C.

Typical values are at +25°C and are given for circuit design information only.

**AC ELECTRICAL CHARACTERISTICS**

(TA=-25°C ~ 75°C)

Characteristics	Sym.	V <sub>DD</sub>	Min.	Typ.	Max.	Unit	Conditions
Oscillator Period	T <sub>OSC</sub>	9	9.5	10.5	11.5	ms	
Led Pulse Period	T <sub>LED1</sub>	9	38.9	43	47.1	s	No Local or Remote Smoke
	T <sub>LED2</sub>	9	None	—	—	s	Remote Smoke only
	T <sub>LED3</sub>	9	0.6	0.67	0.74	s	Local Smoke or Test
Led Pulse Width	T <sub>W(LED)</sub>	9	9.5	—	11.5	ms	
Strobe Pulse Period	T <sub>ST1</sub>	9	9.67	—	11.83	s	No Local or Remote Smoke
	T <sub>ST4</sub>	9	9.67	10.7	11.83	s	Remote Alarm
	T <sub>ST5</sub>	9	38.9	—	47.1	s	Chamber Test or Low Supply Test, No Local Alarm
	T <sub>ST6</sub>	9	0.302	1	0.37	s	Pushbutton Test, No Alarm
Strobe Pulse Width	T <sub>W(ST)</sub>	9	9.5	—	11.5	ms	Remote Alarm
I <sub>RED</sub> Pulse Period	T <sub>IRED1</sub>	9	9.67	—	11.83	s	No Local or Remote Smoke
	T <sub>IRED4</sub>	9	9.67	10.7	11.83	s	No Local or Remote Smoke
	T <sub>IRED5</sub>	9	38.9	—	47.1	s	Chamber Test, No Local Alarm
	T <sub>IRED6</sub>	9	0.302	0.336	0.37	s	Pushbutton Test, No Alarm
I <sub>RED</sub> Pulse Width	T <sub>W(IRED)</sub>	9	94	—	116	μs	
I <sub>RED</sub> Rise Time	T <sub>r(IRED)</sub>		—	—	30	μs	10% to 90%
I <sub>RED</sub> Fall Time	T <sub>f(IRED)</sub>		—	—	200	μs	90% to 10%
Horn Warning Pulse Period	T <sub>HORN</sub>	9	38.9	—	47.1	s	Low Supply and Degraded Chamber Sensitivity
Horn Warning Pulse Width	T <sub>W(HORN)</sub>	9	9.5	—	11.5	ms	Low Supply and Degraded Chamber Sensitivity
Horn ON Time	T <sub>ON(HORN)</sub>	9	120	160	208	ms	Local or Remote Alarm
Horn OFF Time	T <sub>OFF(HORN)</sub>	9	32	80	104	ms	Local or Remote Alarm

\* Limits over the operating temperature range are based on characterization data.

Characteristics are production tested at +25°C.

Typical values are at +25°C and are given for circuit design information only.



PHOTOELECTRIC SMOKE DETECTOR  
WITH INTERCONNECT

M75310

APPLICATION DIAGRAM

(一) STAND-ALONE :

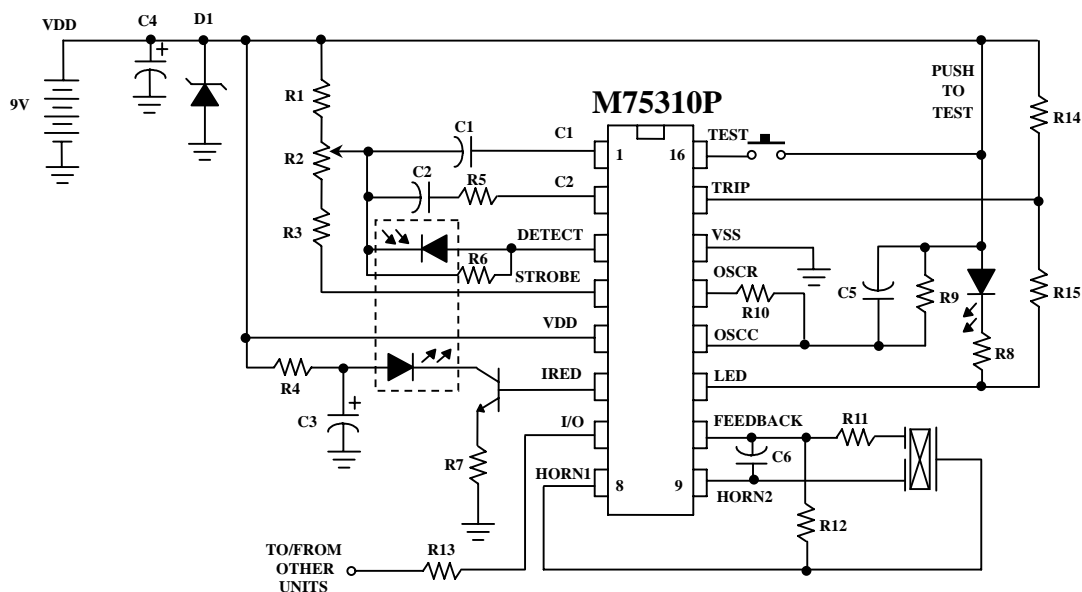

C1	0.047 $\mu$ F	R1	5.6K $\Omega$
C2	4700pF	R2	5K $\Omega$
C3	100 $\mu$ F	R3	8.2K $\Omega$
C4	22 $\mu$ F	R4	1K $\Omega$
C5	1500pF	R5	560 $\Omega$
C6	1000pF	R6	200K $\Omega$
		R7	4.7 $\Omega$ ~ 22 $\Omega$
		R8	330 $\Omega$
		R9	10M $\Omega$
		R10	100K $\Omega$
		R11	200K $\Omega$
		R12	2M $\Omega$
		R13	220 $\Omega$
		R14	100K $\Omega$
		R15	33K $\Omega$

1. Value for R11、R12 and C6 may differ depending on type of piezoelectric horn used.
2. C2 and R7 are used for coarse sensitivity adjustment. Typical values are shown.
3. C4 should be 22  $\mu$ F if B1 is a carbon battery. C4 could be reduced to 1  $\mu$ F when an alkaline battery is used.



PHOTOELECTRIC SMOKE DETECTOR  
WITH INTERCONNECT

(二) NETWORK :

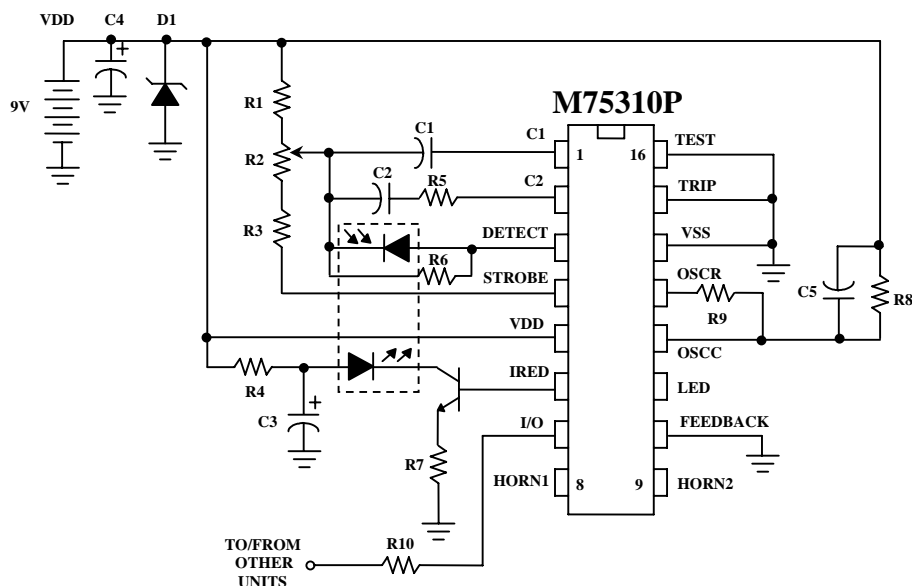

C1	0.047 $\mu$ F	R1	5.6K $\Omega$
C2	4700pF	R2	5K $\Omega$
C3	100 $\mu$ F	R3	8.2K $\Omega$
C4	22 $\mu$ F	R4	1K $\Omega$
C5	1500pF	R5	560 $\Omega$
		R6	200K $\Omega$
		R7	4.7 $\Omega$ ~ 22 $\Omega$
		R8	10M $\Omega$
		R9	100K $\Omega$
		R10	220 $\Omega$

1. C2 and R7 are used for coarse sensitivity adjustment. Typical values are shown.
2. C4 should be 22  $\mu$ F if B1 is a carbon battery. C4 could be reduced to 1  $\mu$ F when an alkaline battery is used.
3. FEEDBACK (PIN10) 、TRIP (PIN15) and TEST (PIN16) must connect to ground.

\* All specs and applications shown above subject to change without prior notice.  
(以上電路及規格僅供參考,本公司得逕行修正)