

PRELIMINARY DATA

23 STAGE COUNTER WITH INTERMEDIATE OUTPUT AT THE 16th STAGE

- LOW QUIESCENT POWER DISSIPATION
- 25% OUTPUT PULSE DUTY CYCLE
- WIDE SUPPLY VOLTAGE RANGE: 3 to 17V
- FULLY PROTECTED INPUTS
- INVERTER AVAILABILITY FOR CRYSTAL OSCILLATOR TIMING APPLICATION
- ADJUSTABLE FREQUENCY DIVIDER IN 127 STEPS
- TEST OUTPUT AVAILABLE
- MOTOR DRIVER BRIDGE CONFIGURATION OUTPUT

The M754 (standard temperature range) is a 23 stage binary counter in COS/MOS technology in a single monolithic chip. An inverter is available for crystal oscillator application in which the function of the trimmer capacitor has been taken over by the variable frequency divider comprised in the IC and used to set the correct output frequency. For this purpose seven adjustment terminals are provided on the M754; they are used to set the divider ratio to the required value with an accuracy of 10^{-6} . The adjustable frequency divider has been designed in such a way that the maximum output frequency is set when all adjustment terminals are either open-circuit or connected to pin 16. If one or more adjustment terminals are grounded (taken to pin 14), the output frequency decreases. With an oscillator frequency of 4.194812 MHz the bridge configuration outputs supply two square wave signals whose frequency is 0.5 Hz; the pulse duty factor is 0.25 and their relative delay is of half period. The intermediate output provides a 64 Hz signal with pulse duty cycle of 50%. The by-four-divider oscillator frequency may be checked at a separate test output (pin 9) non-reactive with respect to the oscillator. The device is available in 16 lead dual in-line plastic or ceramic package.

ABSOLUTE MAXIMUM RATINGS*

V_{DD}^{**}	Supply voltage	-0.3 to +17	V
I_{12}, I_{13}	Output current	30	mA
P_{tot}	Power dissipation at $T_{amb} = 25^{\circ}\text{C}$	200	mW
T_{op}	Operating temperature range	-40 to +85	$^{\circ}\text{C}$
T_{stg}	Storage temperature range	-55 to +125	$^{\circ}\text{C}$

* Stresses above those listed under "Absolute Maximum Ratings" may cause permanent damage to the device. This is a stress rating only and functional operation of the device at these or any other condition above those indicated in the operational sections of this specification is not implied. Exposure to absolute maximum rating conditions for extended periods may affect device reliability.

** All voltages are referred to V_{SS} pin voltage.

ORDERING NUMBERS: M754 B1 for dual in-line plastic package
M754 D1 for dual in-line ceramic package frit seal

M 754

MECHANICAL DATA (dimension in mm)

For dual in-line ceramic package, frit seal

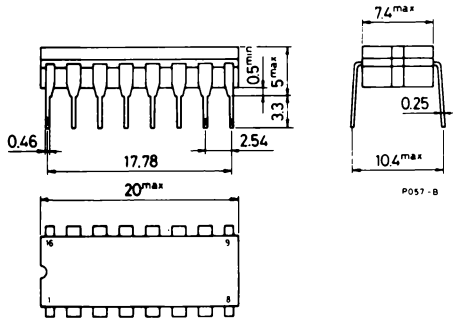

For dual in-line plastic package

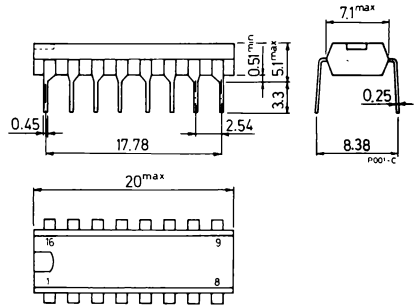

PIN CONNECTIONS

BLOCK DIAGRAM and OUTPUT WAVEFORM

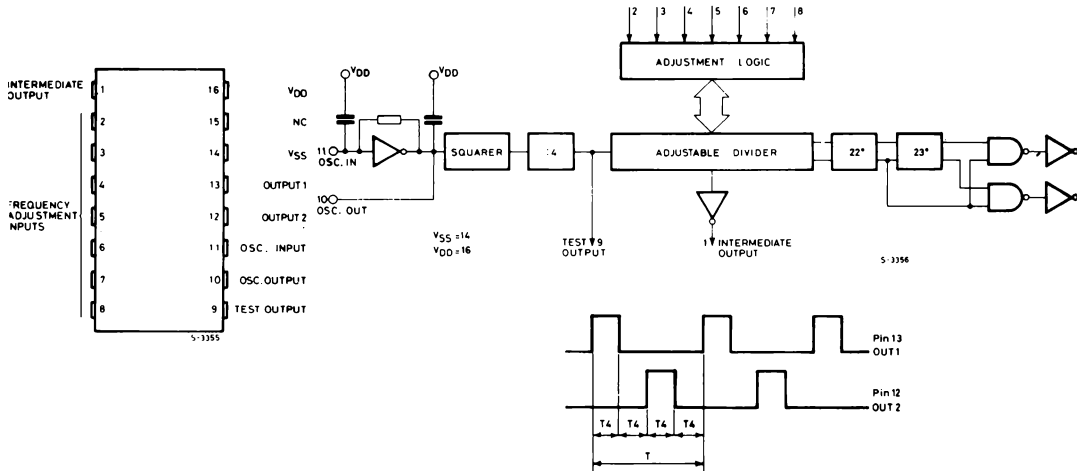

RECOMMENDED OPERATING CONDITIONS

V_{DD}	Supply voltage: for general applications for oscillator starting	3 to 16.5	V
V_i	Input voltage	6 to 16.5	V
R_L	Output load resistance between pins 12 and 13	V_{DD} to V_{SS}	V
T_{op}	Operating temperature range	300	Ω
		-40 to +85	$^{\circ}\text{C}$

STATIC ELECTRICAL CHARACTERISTICS (over recommended operating conditions)

Parameter	Test conditions		Values									Unit
	V _O (V)	V _{DD} (V)	-40° C			25° C			85° C			
			Min.	Typ.	Max.	Min.	Typ.	Max.	Min.	Typ.	Max.	
V _{OH} Output high voltage	I _{OH} = 0	6	5.99			5.99	6		5.95			V
		12	11.99			11.99	12		11.95			
V _{OL} Output low voltage	I _{OL} = 0	6			0.01		0	0.01			0.05	V
		12			0.01		0	0.01			0.05	
I _{DN} Output drive current P-channel	pin 12-13	2	6	10.5		10	12.5		6.5			mA
		2	12	17		16.5	20		6.5			
I _{DP} Output drive current N-channel	pin 12-13	4	6	-10.5		-10	-12.5		-6.5			mA
		10	12	-17		-16.5	-20		-6.5			
I _{ON} Current consumption	I _O = 0*		12				3					mA

* At quartz frequency of 4.194.812 Hz.

DYNAMIC ELECTRICAL CHARACTERISTICS (T_{amb} = 25°C, quartz frequency 4.194.812 Hz)

Parameter	Test conditions		Values						Unit
	V _{DD} (V)		M754 D1			M754 B1			
			Min.	Typ.	Max.	Min.	Typ.	Max.	
f _T Frequency test output		12	1.048703			1.048703			Hz
f _o ** Output frequency		12		0.5			0.5		Hz
$\frac{\Delta f_o}{f_o}$ Range output frequency adjustment		12		± 121			± 121		ppm
R _o Total bridge output resistance	R _L = 300Ω	6			300			300	Ω

** At the centre position of the variable divider.

M 754

APPLICATION CIRCUIT

