



M7612

LINEAR INTEGRATED CIRCUIT

VIDEO SIGNAL SWITCHER

■ DESCRIPTION

The UTC **M7612** is three-channel analog multiplexes and designed for use in TV and video cassette recorders. It is characterized by a large dynamic range and wide operating frequency range.

■ FEATURES

- *3-input / 1-output switches.
- *Built-in mute 6dB amplifier and 75Ω driver.
- *Large input impedance (20kΩ Typ.).
- *Wide operating supply voltage range
(4.5V ~ 13.0V for SIP-8 package)
(4.5V ~ 9.5V for SOP-8 package).
- *Low power dissipation (103mW Typ.).
- *Excellent frequency characteristics (10MHz, 0dB Typ.).
- *Wide dynamic range (3.5V_{P-P} Typ.).
- *Low interchannel crosstalk (– 65dB Typ., f = 4.43MHz).

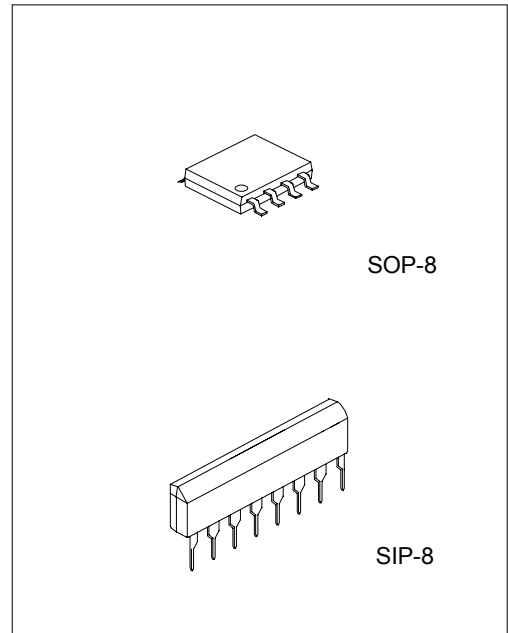

*Pb-free plating product number: M7612L

■ ORDERING INFORMATION

Ordering Number		Package	Packing
Normal	Lead Free Plating		
M7612-S08-T	M7612L-S08-T	SOP-8	Tube
M7612-S08-R	M7612L-S08-R	SOP-8	Tape Reel
M7612-G08-T	M7612L-G08-T	SIP-8	Tube

■ PIN CONFIGURATIONS

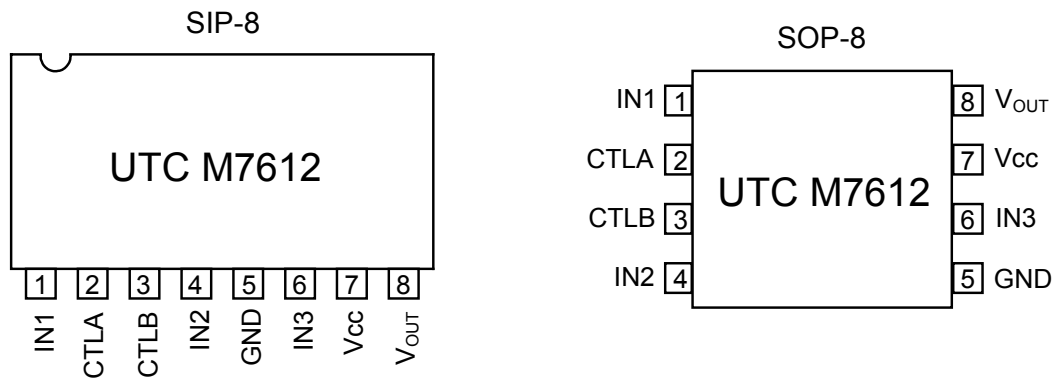

■ TRUTH TABLE

CTL A	CTL B	OUT
L (OPEN)	L (OPEN)	IN1
L (OPEN)	H	IN2
H	L (OPEN)	IN3
H	H	MUTE

■ ABSOLUTE MAXIMUM RATINGS (Ta=25)

PARAMETER		SYMBOL	RATINGS	UNIT
Power Supply Voltage	SIP-8	V _{CC}	13.5	V
	SOP-8		10.0	
Power Dissipation	SIP-8	P _D	900	mW
	SOP-8		550	
Operating Temperature		T _{OPR}	0 ~ +70	
Storage Temperature		T _{STG}	-40 ~ +150	

■ ELECTRICAL CHARACTERISTICS (Ta=25 , Vcc=5V, unless otherwise specified.)

PARAMETER		SYMBOL	TEST CONDITIONS	MIN	TYP	MAX	UNIT
Operating Voltage Range	SIP-8	V _{CC}		4.5		13.0	V
	SOP-8			4.5		9.5	V
Supply Current		I _{CC}			20.5	29.0	mA
Maximum Output Level		V _{OM}	f=1kHz, THD=0.5%	3.0	3.5		Vp-p
Voltage Gain		G _V	f=1MHz, V _{IN} =1.0Vp-p	5.5	6.0	6.5	dB
Interchannel Crosstalk		C _T	f=4.43MHz, V _{IN} =1.0Vp-p		-65		dB
Frequency Characteristic		C _F	f=10MHz/1MHz, V _{IN} =1.0Vp-p	-3.0	0	1.0	dB
Input Impedance		Z _{IN}		14	20	26	kΩ
CTL Pin Switching Level A		V _{TH-A}		1.0	2.0	3.0	V
CTL Pin Switching Level B		V _{TH-B}		1.0	2.0	3.0	V

*Not designed for radiation resistance.

■ MEASUREMENT CONDITIONS

PARAMETER		SYMBOL	SWITCH SETTINGS					MEASUREMENT METHOD
			SW ₁	SW ₂	SW ₃	SW ₄	SW ₅	
Current Dissipation		I _{CC}	2	2	2	2	2	Ammeter
Maximum Output Level	I _{N1}	V _{OM}	1	2	2	3	3	f=1kHz, THD=0.5% see Test Notes 2
	I _{N2}	V _{OM}	2	1	2	3	2	
	I _{N3}	V _{OM}	2	2	1	2	3	
Voltage Gain	I _{N1}	G _V	1	2	2	3	3	f=1MHz, V=1Vp-p see Test Notes 3
	I _{N2}	G _V	2	1	2	3	2	
	I _{N3}	G _V	2	2	1	2	3	
Interchannel Crosstalk	I _{N1} →I _{N2}	C _T	1	2	2	3	2	f=4.43MHz, V=1Vp-p see Test Notes 4
	I _{N1} →I _{N3}	C _T	1	2	2	2	3	
	I _{N1} →MUTE	C _T	1	2	2	2	2	
	I _{N2} →I _{N3}	C _T	2	1	2	2	3	
	I _{N2} →MUTE	C _T	2	1	2	2	2	
	I _{N3} →MUTE	C _T	2	2	1	2	2	
Frequency Characteristic	I _{N1}	G _F	1	2	2	3	3	f=10MHz/f=1MHz V=1Vp-p see Test Notes 5
	I _{N2}	G _F	2	1	2	3	2	
	I _{N3}	G _F	2	2	1	2	3	
CTL Pin Switching Level	CTL A	V _{TH}	2	2	1	1	3	see Test Notes 6
	CTL B	V _{TH}	2	1	2	3	1	

■ TEST CIRCUIT

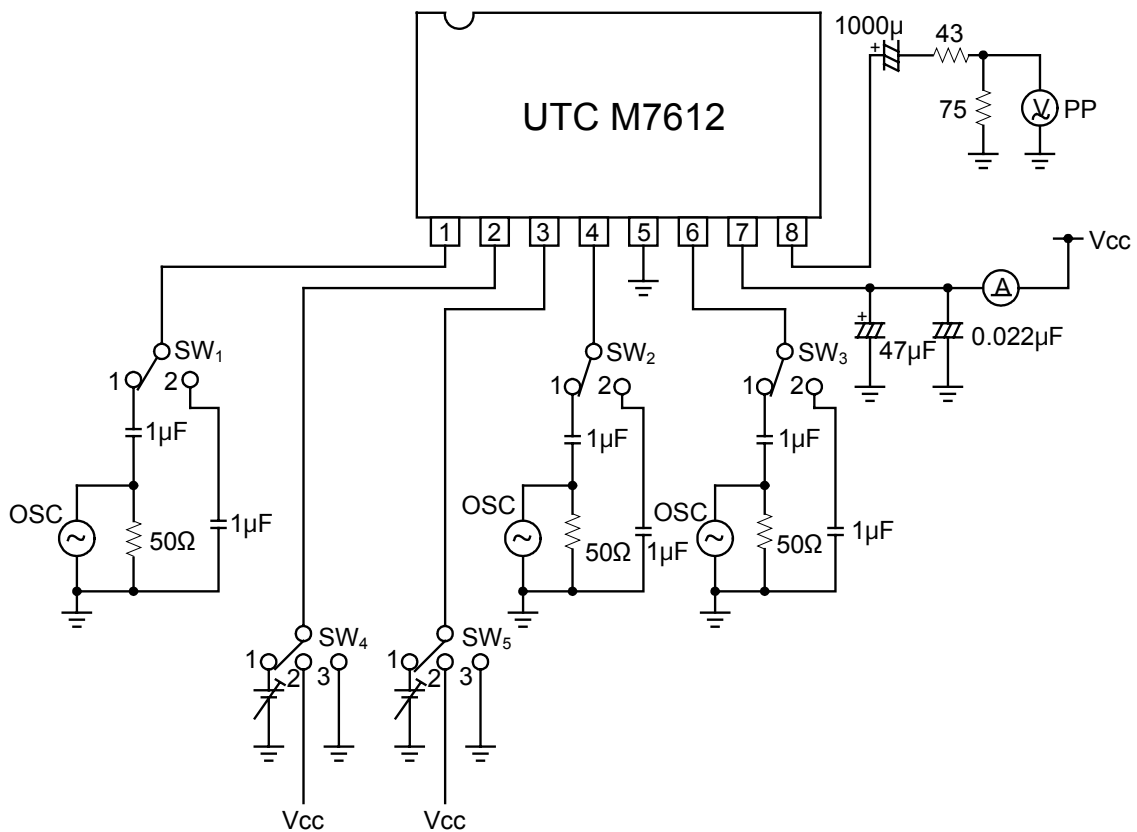

■ TEST NOTES

1. The output impedance is approximately 32Ω. Therefore, to ensure output matching, connect an external resistor of 43Ω.
2. Connect a distortion meter to the output, and input a $f = 1\text{kHz}$ sine wave. Adjust the input level until the output distortion is 0.5%. This output voltage at this time multiplied by 2 is the maximum output level V_{om} (V_{P-P}).
3. Input a $1V_{P-P}$, 1MHz sine wave. The voltage gain is given by $G_V = 20 \log (V_{OUT} / V_{IN}) + 6$.
4. Input a $1V_{P-P}$, 4.43MHz sine wave. The interchannel crosstalk is given by $C_T = 20 \log (V_{OUT} / V_{IN})$.
5. Input $1V_{P-P}$, 1MHz and 10MHz sine waves.
The frequency characteristic is given by $G_F = 20 \log (V_{OUT} (f = 10\text{MHz}) / V_{OUT} (f = 1\text{MHz}))$.
6. Input a $1V_{P-P}$, 1MHz sine wave. Reduce the CTL pin voltage from V_{CC} . The CTL pin switching level (V_{TH}) is the CTL pin voltage at which the V_{OUT} level drops below $20mV_{P-P}$.

■ TYPICAL CHARACTERISTIC

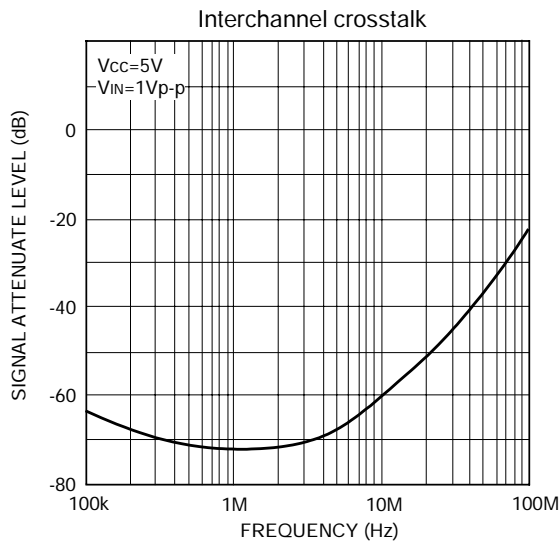
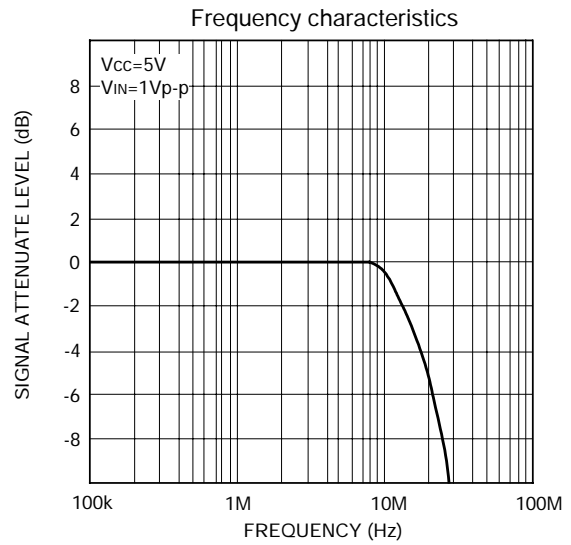
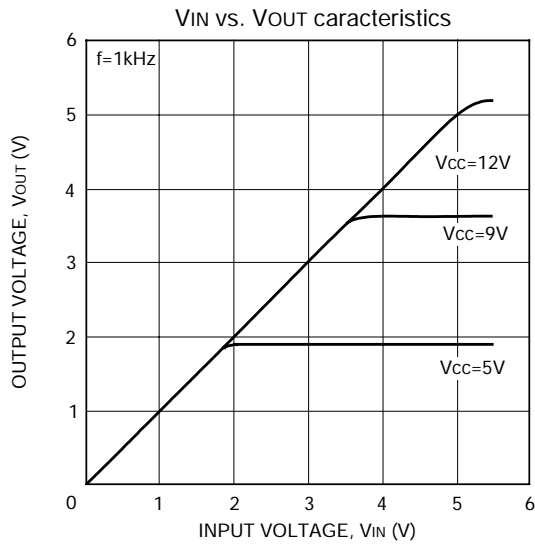

UTC assumes no responsibility for equipment failures that result from using products at values that exceed, even momentarily, rated values (such as maximum ratings, operating condition ranges, or other parameters) listed in products specifications of any and all UTC products described or contained herein. UTC products are not designed for use in life support appliances, devices or systems where malfunction of these products can be reasonably expected to result in personal injury. Reproduction in whole or in part is prohibited without the prior written consent of the copyright owner. The information presented in this document does not form part of any quotation or contract, is believed to be accurate and reliable and may be changed without notice.