

DUAL TONE MULTIFREQUENCY GENERATOR

- 2.4 TO 4 V SUPPLY RANGE
- VERY LOW POWER CONSUMPTION
- ON-CHIP CRYSTAL CONTROLLED OSCILLATOR ($f_0 = 4.433619$ MHz) WITH INTEGRATED FEEDBACK RESISTOR AND LOAD CAPACITORS
- LOW HARMONIC DISTORTION ($\leq 2\%$)
- FIXED PRE-EMPHASIS ON HIGH-GROUP TONES
- FAST START-UP TIME
- LOW POWER CONSUMPTION IN STANDBY MODE
- MUTE OUTPUT
- ONE CONTACT PER KEY

DESCRIPTION

The M761 provides all the tone frequency pairs required for a DTMF Dialling System. Tones are obtained from an inexpensive TV crystal ($f_0 = 4.433619$ MHz) followed by two independent programmable dividers. The dividing ratio is controlled by the selected key. Keyboard format is 4 rows x 4 columns and a key is valid when a column and a row are connected together.

Internal logic prevents the transmission of illegal tones when more than one key is pressed. If no key is selected the oscillator turns off and the linear parts are strobed to decrease the total power consumption.

As any button is pressed row and column inputs are scanned internally, to identify the activated ones. Electrically, row and column inputs are activated on high level voltage.

Single tone output cannot be emitted by a "1" on a row or column only. For single tone emission see "Single tone procedure".

A debounce output is available to indicate that a key has been selected. D/A conversion is accomplished by a capacitive network allowing very low power consumption, very low distortion and an exceptional stability of tone level against temperature variations.

The tones are mixed in a resistive network ; a unity gain amplifier is provided to realize a two pole active filter with only four external passive components.

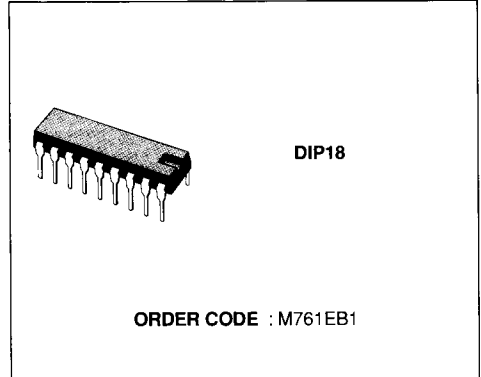

The M761 can be interfaced with the speech circuit family LS156, LS356, LS656 with MF interface avoiding the need of the common spring set.

The M761 utilizes low voltage CMOS technology and is available in 18 pin dual in-line plastic package.

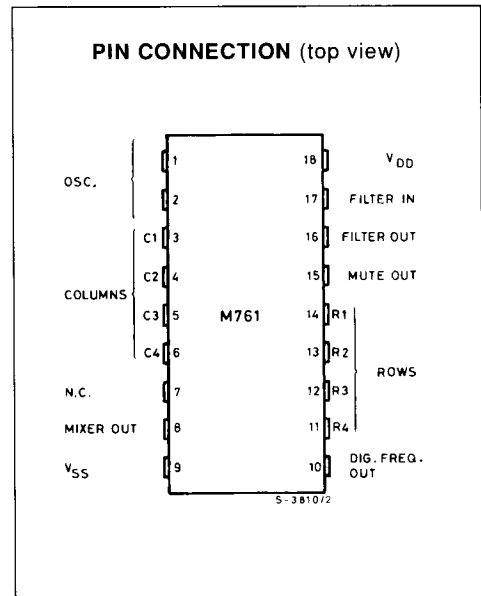

BLOCK DIAGRAM

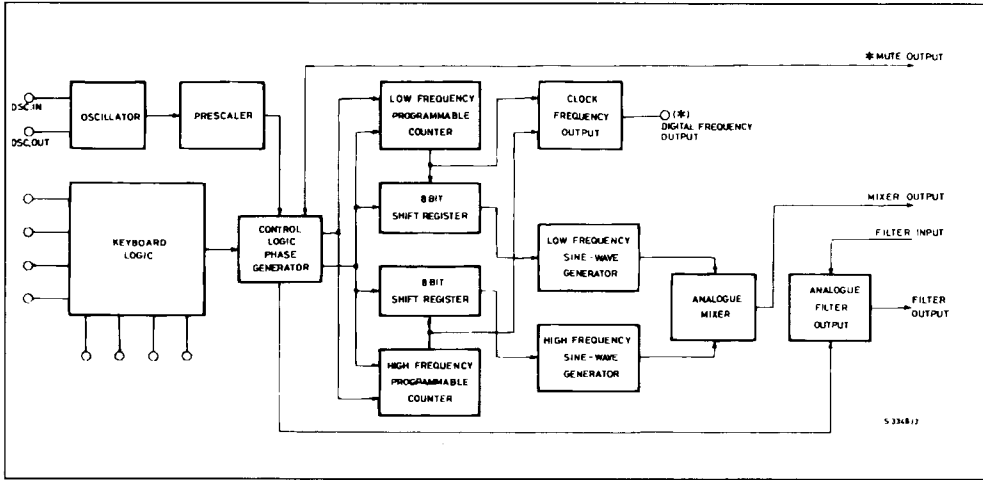

ABSOLUTE MAXIMUM RATINGS

Symbol	Parameter	Value	Unit
V_{DD}	Supply Voltage	- 0.5 to + 5.5	V
V_I	Input Voltage	- 0.3 to $V_{DD} + 0.5$	V
P_{tot}	Power Dissipation	400	mW
T_{op}	Operating Temperature Range	- 25 to + 70	°C
T_{stg}	Storage Temperature Range	- 55 to + 125	°C

THERMAL DATA

$R_{thj-amb}$	Thermal Resistance Junction-ambient	Max	100	°C/W
---------------	-------------------------------------	-----	-----	------

ELECTRICAL CHARACTERISTICS (all parameters are tested at $T_{amb} = 25\text{ }^{\circ}\text{C}$)

Parameter	Test Conditions (see note 1)	Min.	Typ.	Max.	Unit
-----------	---------------------------------	------	------	------	------

DC CHARACTERISTICS

Supply	V_{DD} Voltage Supply Voltage		2.4	3	4	V
	I_{DD} Operating Supply Current	$V_{DD} = 2.4\text{ V}$			1.8	mA
	I_{DDO} Stand-by Supply Current	$V_{DDO} = 2.55\text{ V}$			0.3	mA
Row and Column Inputs	Input Voltage Levels					
	V_{IH} Logical "1"			80 % of $(V_{DD}-V_{SS})$	$V_{DD} + 0.3$	V
	V_{IL} Logical "0"			$V_{SS} - 0.3\text{ V}$	20 % of $(V_{DD}-V_{SS})$	V
	C_{IN} Input Capacitance Any Pin				7.5	pF
Oscillator	I_{IH} High Level Input Current	$V_{DD} = 2.5\text{ V}$ $V_{IN} = 2.5\text{ V}$			1	μA
	I_{IL} Low Level Input Current	$V_{DD} = 2.5\text{ V}$ $V_{IL} = 0\text{ V}$			1	μA
	I_{OH} High Level Output	$V_{DD} = 2.5\text{ V}$ $V_{OH} = 2\text{ V}$	- 100	- 500		μA
	I_{OL} Low Level Output Current	$V_{DD} = 2.5\text{ V}$ $V_{OL} = 0.5\text{ V}$	100	500		μA
Digit. Freq. Outp.	I_{OL} Low Level Output Current (open drain output)	$V_{DD} = 2.5\text{ V}$ $V_{OL} = 1\text{ V}$	100			μA
Filter	V_O Output DC Voltage Without Tones	$V_{DD} = 2.5\text{ V}$			200	mV
	V_O Output DC + AC Voltage with 2 Tones	$V_{DD} = 2.5\text{ V}$ (see note 2) (see fig. 1)	0.63	0.84	1.05	V
Mute Output	I_{OH} Output Drive Current	$V_{DD} = 2.5\text{ V}$ $V_{OH} = 1.5\text{ V}$	- 100			μA
	I_{OL} Output Sink Current	$V_{DD} = 2.5\text{ V}$ $V_{OL} = 1\text{ V}$	20			μA

Notes : 1. This device has been designed to be connected to the DTMF interface of the speech circuit family LS156, LS356, LS656 from which it takes a $V_{DD} = 2.4\text{ V}$ min. Therefore many parameters are tested at this value.

2. The value of DC output component at two different conditions of supply voltage, with two tones activated, can be related as follows :

$$V_{DC'} = V_{DC} \frac{V_{DD'}}{V_{DD}}$$

3. The value of AC output components (V_{LF} , V_{HF}) at two different conditions of supply voltages can be related as follows :

$$V_{LF} = V_{LF} \frac{V_{DD'}}{V_{DD}} \quad V_{HF} = V_{HF} \frac{V_{DD'}}{V_{DD}}$$

The values are measured with two tone at the output.

ELECTRICAL CHARACTERISTICS (all parameters are tested at $T_{amb} = 25\text{ }^{\circ}\text{C}$)

Parameter	Test Conditions (see note 1)	Min.	Typ.	Max.	Unit
-----------	---------------------------------	------	------	------	------

AC CHARACTERISTICS

Oscillator	R_F	Feedback Oscillator Resistance		1.5	4.5		$M\Omega$
	C_I	Input Capacitance to V_{DD}			9.5	10.5	pF
	C_O	Output Capacitance to V_{DD}			10.5	11.5	pF
Mixer	Z_{O1}	Output Dynamic Impedance with 2 Tones	$V_{DD} = 2.5\text{ V}$		10		$K\Omega$
Filter	Z_{O2}	Output Dynamic Impedance with 2 Tones	$V_{DD} = 2.5\text{ V}$		2.5		$K\Omega$
Tone Characteristics	$\frac{\Delta F}{F}$	Max. Output Tone Derivation from Standard R1 697 Hz R2 770 Hz R3 852 Hz R4 941 Hz C1 1209 Hz C2 1336 Hz C3 1477 Hz C4 1633 Hz	At Crystal Frequency $f = 4.433619\text{ MHz}$			+ 0.5 - 0.2 + 0.5 - 0.6 + 0.6 - 0.4 - 0.3 + 1.1	% % % % % % % %
	V_{LF}	Low Frequency Tones Amplitude at Filter Out	$V_{DD} = 2.5\text{ V}$ (see note 3) (see fig. 2)	124		148	mV_{PP}
	V_{HF}	High Frequency Tones Amplitude at Filter Out	$V_{DD} = 2.5\text{ V}$ (see note 3) (see fig. 2)	157		187	mV_{PP}
		Pre-emphasis		1.25	2	2.75	dB
		Unwanted Frequency Components at $f = 3.4\text{ KHz}$ at $f = 50\text{ KHz}$				- 33 - 80	dBm dBm
		Total Harmonic Distortion for a Single Frequency	$V_{DD} = 2.5\text{ V}$			5	%
		t_s Start-up Time	$V_{DD} + 2.5\text{ V}$ (see fig. 4) (see fig. 5)		3	5	ms
		t_r Supply Voltage Rise Time	$V_{DD} = 2.5\text{ V}$			250	ms

- Notes :**
- This device has been designed to be connected to the DTMF interface of the speech circuit family LS156, LS356, LS656 from which it takes a $V_{DD} = 2.4\text{ V}$ min. Therefore many parameters are tested at this value.
 - The value of DC output component at two different conditions of supply voltage, with two tones activated, can be related as follows :

$$V_{DC} = V_{DC} \frac{V_{DD'}}{V_{DD}}$$

- The value of AC output components (V_{LF} , V_{HF}) at two different conditions of supply voltages can be related as follows :

$$V_{LF} = V_{LF} \frac{V_{DD'}}{V_{DD}} \quad V_{HF} = V_{HF} \frac{V_{DD'}}{V_{DD}}$$

The values are measured with two tone at the output.

FUNCTIONAL DESCRIPTION

OSCILLATOR (OSC. IN - OSC. OUT)

The oscillator circuit has been designed to work with a 4.433619 MHz crystal ensuring both fast start-up time and low current consumption.

When V_{DD} is applied and a key is activated two inverters are paralleled (see fig. below) to decrease the total r_{ON} resistance.

After oscillations have started one of the two buffers

is switched off and the current consumption is reduced to 2/3 of the initial value.

Feedback resistance and load capacitances are integrated on the chip ensuring good temperature performance.

When the device is supplied but no key is activated, the oscillator is in the stand-by mode to minimize power consumption.

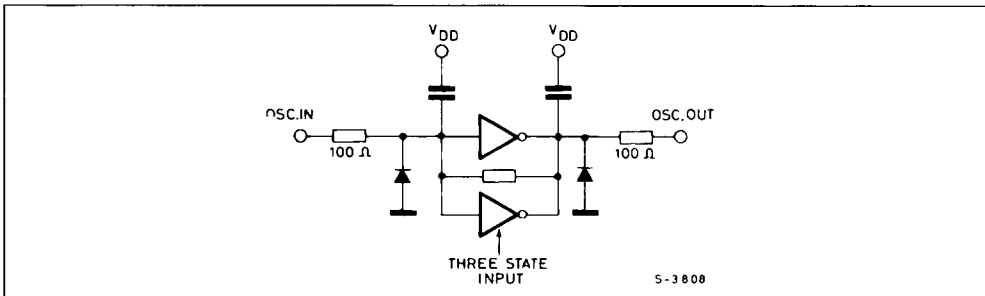

KEYBOARD INPUTS

(C1, C2, C3, C4 - R1, R2, R3, R4)

Each keyboard input has an internal protection circuit ; when a button is pressed, the oscillator starts and dynamic scanning of keyboard is realised.

This allows to the detection of which button has been pressed.

When two or more column or row inputs are activated no tone is generated.

DIGITAL FREQUENCY OUTPUT

This output is intended for testing only ; when a single tone is activated, at this output is available a digital signal whose frequency is 16 times the selected output tone frequency. This output is an open collector N-channel transistor.

MIXER OUTPUT

The two reconstructed sine waves are buffered then mixed in a resistive array network that also restores the DC output level.

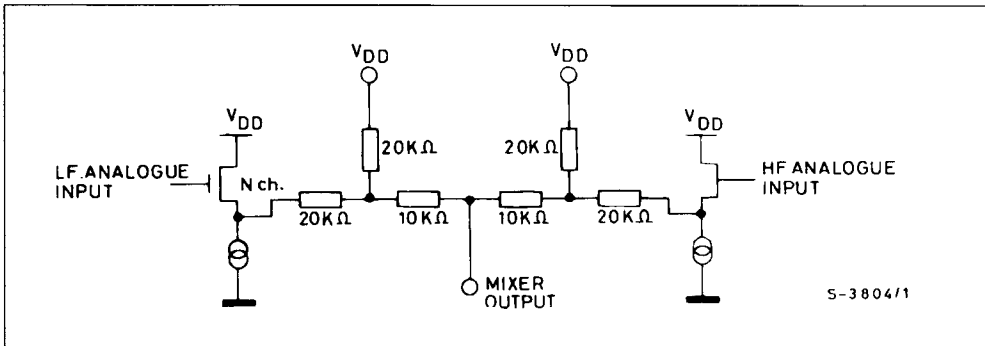
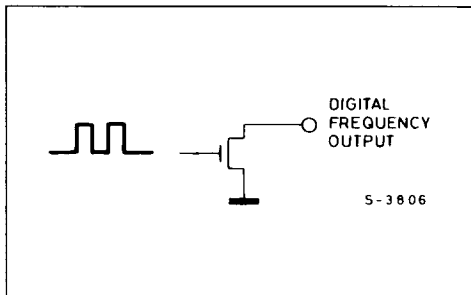

FILTER (Filter Input, Filter Output)

A unity gain amplifier is available to realize a two pole active filter (see fig. below). The output of this amplifier is held low until tones are valid, it then rises to about 0.85 V at $V_{DD} = 2.5$ V.

Tones are superimposed on this DC.

The output DC component is very precise and stable to allow DC coupling with the LS156 speech circuit with MF interface.

The output dynamic impedance of the filter is about 2.5 K Ω .

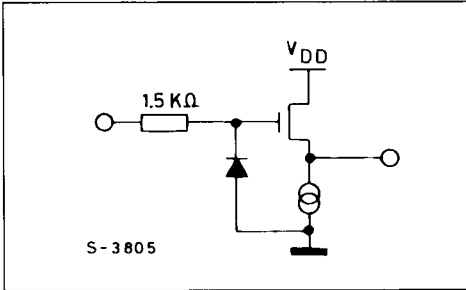

The following equivalent circuit should be applied during filter design :

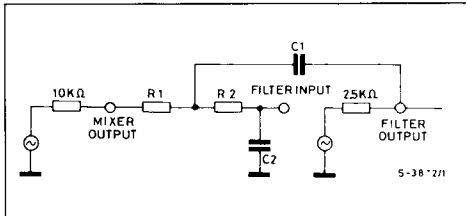

It is evident that R1 and R2 should be kept high to avoid undue influence of Mixer and Filter output impedances.

The following values are suggested :

$R1 = 56\text{ K}\Omega \pm 2\%$

$R2 = 33\text{ K}\Omega \pm 2\%$

$C1 = 2.2\text{ nF} \pm 10\%$

$C2 = 0.56\text{ nF} \pm 10\%$

MUTE OUTPUT

Mute output becomes active when a key is activated eliminating keyboard bounces and remains active for all the duration of tone transmission.

If the key is released before the oscillator produces the correct control signals, mute output is disabled.

SINGLE TONE PROCEDURE

This is accomplished through the following steps :

- 1) Activate simultaneously R1, R4, C1, C4 inputs, applying logic '1's. This implies the use of logic level sources. The single contact keyboard does not allow this procedure.
- 2) The device enters the "test mode" Now any single row or column frequency (or both) can be activated at output applying logic "1" to correspondent input (inputs).
- 3) To get out from "test mode" reply R1, R4, C1, C4, activation or power off/power on.

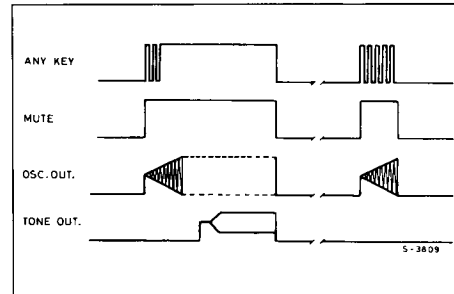

Figure 1 : DC + AC Out Level Measurement Test Set.

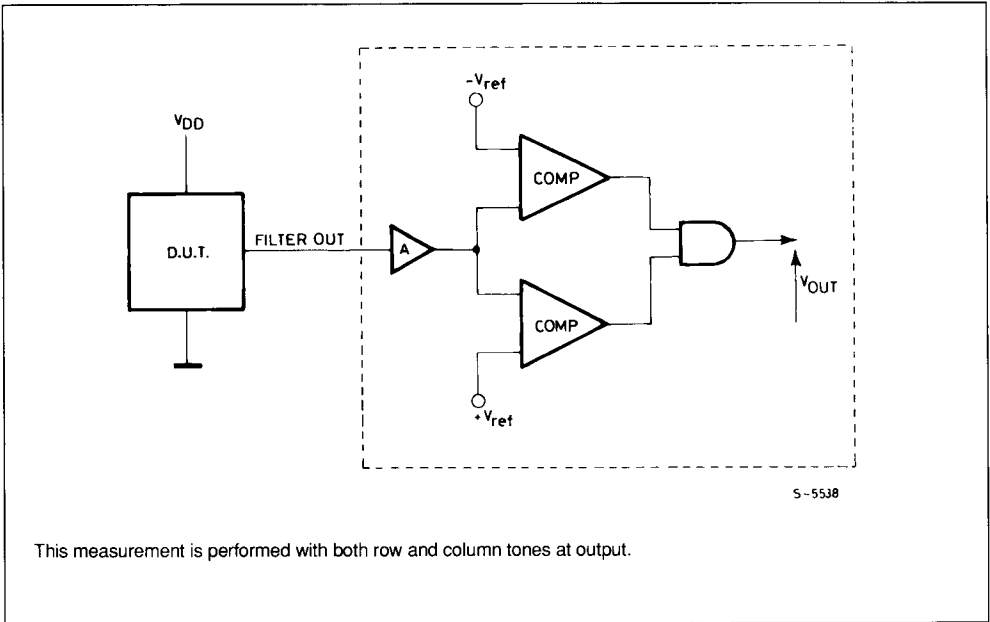

Figure 2 : Out Tone Level Measurement Test Set.

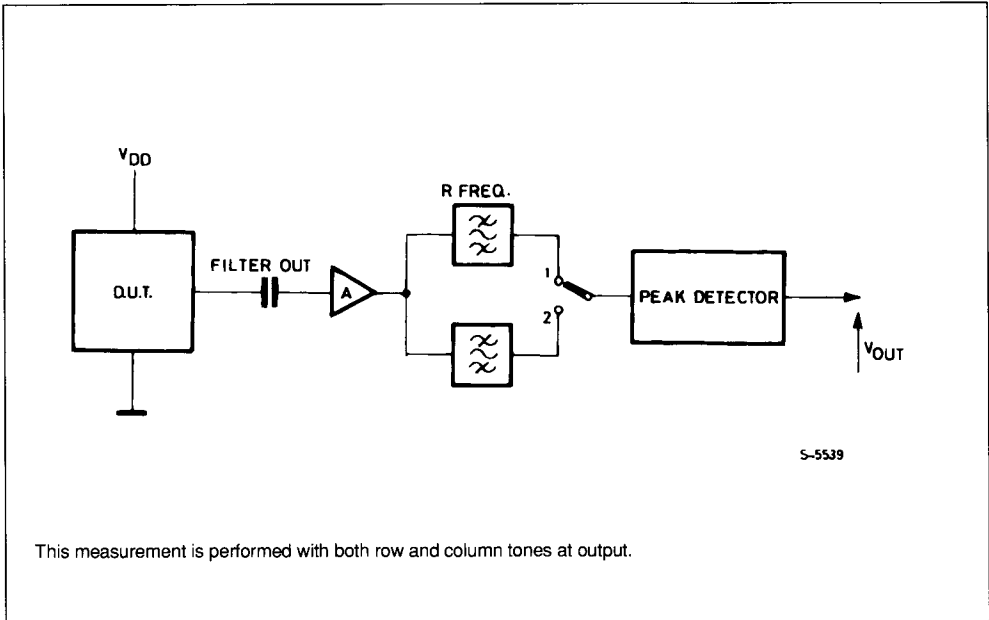

Figure 3 : THD Measurement Test Set.

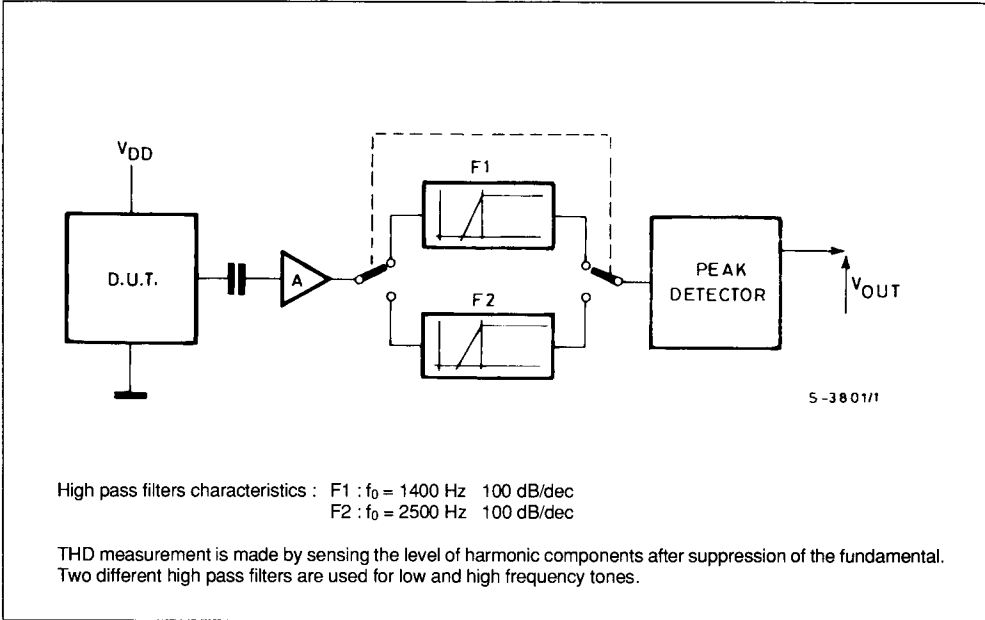

Figure 4 : Start-up time Measurement Test Set.

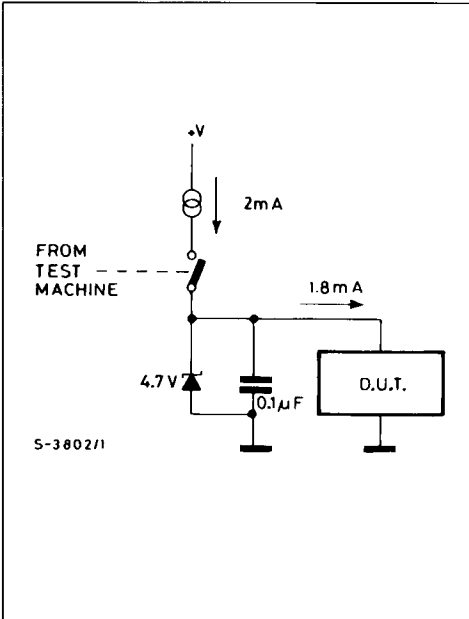
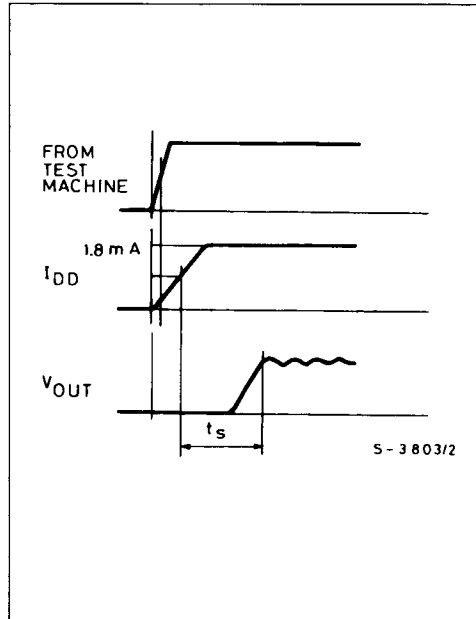

Figure 5 : Start-up time Definition.



TYPICAL APPLICATIONS

Figure 6 : M761 application circuit with electronic speech circuit.

