



**ANALOG  
SYSTEMS**

MA-322

**LOW-NOISE  
WIDEBAND  
OPERATIONAL AMPLIFIER**

**FEATURES**

3.5nV//Hz INPUT NOISE VOLTAGE  
 $\pm 20$  V/ $\mu$ S SLEW RATE  
 50 MHz GAIN-BANDWIDTH PRODUCT  
 600 $\mu$ V UNTRIMMED OFFSET VOLTAGE  
 $\pm 40$ mA OUTPUT LOAD CURRENT

**APPLICATIONS**

AUDIO AMPLIFIERS  
 DATA ACQUISITION AMPLIFIERS  
 ACTIVE FILTERS  
 PRECISION LINE DRIVER

**FUNCTIONAL DIAGRAM**

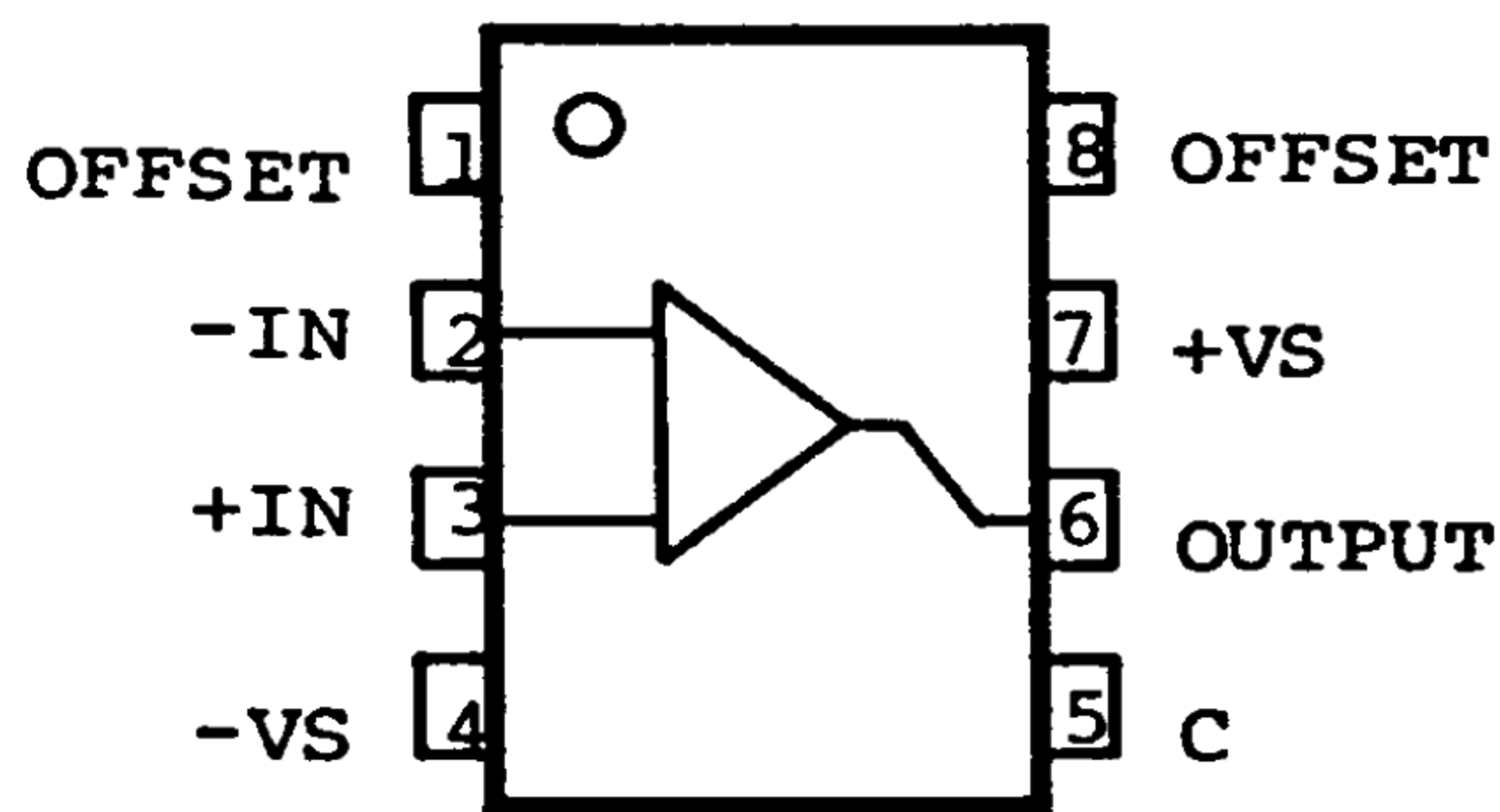

Order Part Number MA-322-CP  
 Epoxy Molded 8-pin mini-DIP

**GENERAL DESCRIPTION**

MA-322 is a differential bipolar input operational amplifier with a low noise input stage. Other unique areas include wide bandwidth with unity gain stability and moderately high output drive capability.

Input anti-parallel diodes are used to protect the input stage devices and prevent reverse breakdown of the base junction - an occurrence which would cause the low noise input characteristics to deteriorate.

Pin 5 is brought out to allow over-compensation for lowest noise possible under capacitive load, capacitive source or integrator applications. A 33pF capacitor is connected from pin 5 to pin 8 for these applications.

**SIMPLIFIED SCHEMATIC**

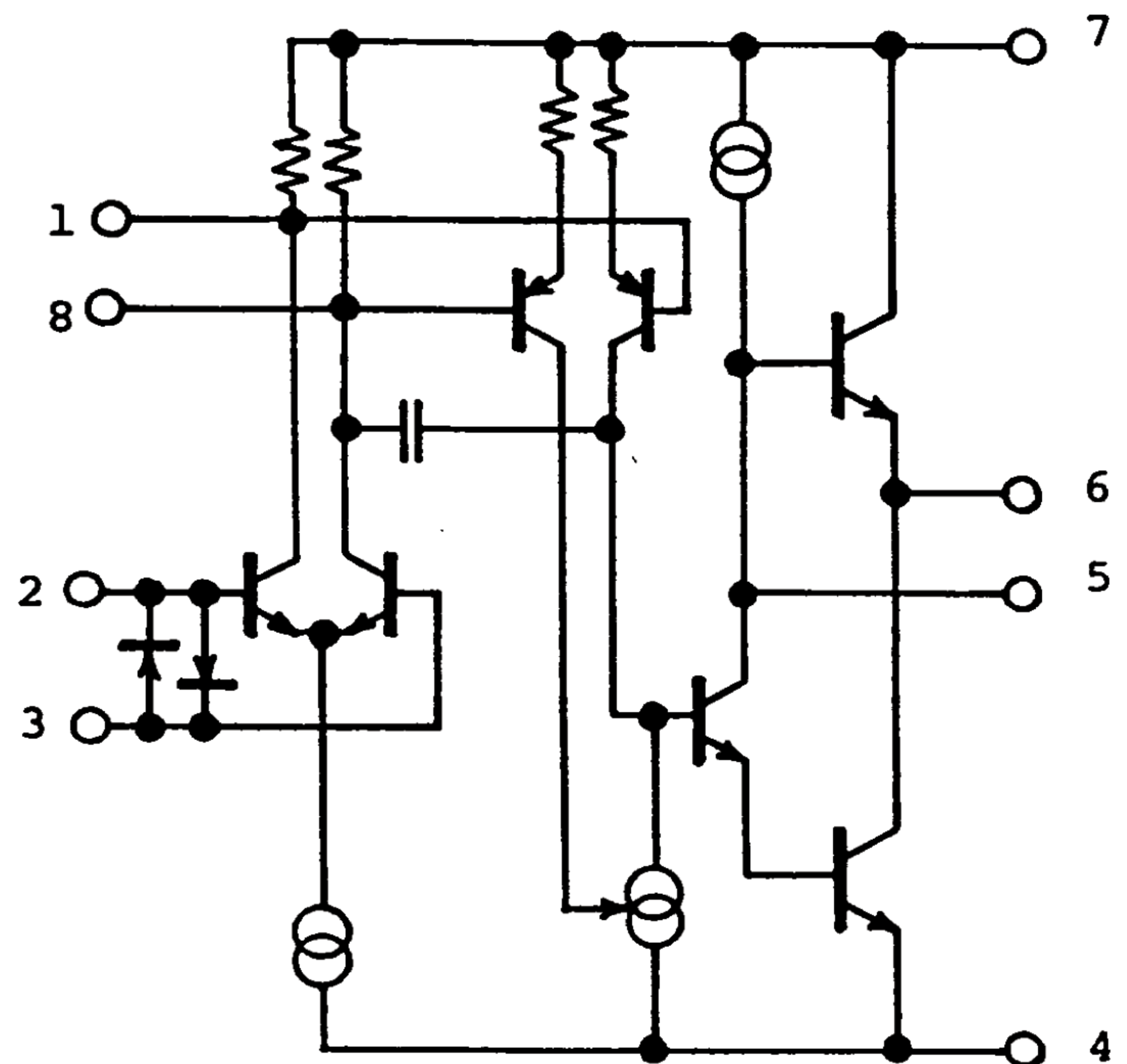

# ELECTRICAL CHARACTERISTICS

## ABSOLUTE MAXIMUM RATINGS

Supply Voltage (Between +VS and -VS terminals)	40 Volts
Differential Input Voltage	0.5 Volt
Common Mode Input Voltage	$\pm$ v Supply
Power Dissipation	500 Milliwatts
Operating Temperature Range	-55°C to +75°C
Storage Temperature Range	-65°C to +150°C
Lead Temperature (Soldering, 10 seconds)	+300°C

SPECIFICATIONS,  $\pm$ VS = 15V, +25°C

## INPUT

Noise Voltage <sup>1</sup>	Typical	3.5nV/ $\sqrt{\text{Hz}}$
	Maximum	5.0nV/ $\sqrt{\text{Hz}}$
Noise Current <sup>1</sup>	Typical	0.5pA/ $\sqrt{\text{Hz}}$
	Maximum	1.0pA/ $\sqrt{\text{Hz}}$
Offset Voltage	Maximum	2.0 millivolts
Offset Voltage Drift	Maximum	15uV/°C
Bias Current	Maximum	750nA
Offset Current	Maximum	150nA
Common Mode Voltage	Minimum	$\pm$ 12 Volts
Common Mode Rejection	Minimum	90dB

OPEN LOOP GAIN at DC

Minimum 94dB

## DYNAMIC RESPONSE

Slew Rate  
Gain-Bandwidth Product<sup>2</sup>

Minimum  $\pm$ 15V/ $\mu$ S  
Minimum 40MHz

## OUTPUT

Voltage Swing - no load  
Load Current -  $\pm$ 10 Volt  
Full Power Bandwidth

Minimum  $\pm$ 12 Volts  
Minimum  $\pm$ 30mA  
Minimum 240kHz

## POWER SUPPLY

Current  
Minimum Voltage

Maximum  $\pm$ 7mA  
 $\pm$ 2.5V

- NOTES: 1. Noise Voltage and Current are measured with a bandwidth of 300Hz to 10kHz.  
2. Gain-Bandwidth Product is measured at closed loop gain of 100X (40dB).

ANALOG SYSTEMS reserves the right to change any Ratings and Specifications at any time. Information furnished by ANALOG SYSTEMS is believed to be accurate, however, no responsibility is assumed by ANALOG SYSTEMS for its use; nor for any infringements of patents or other rights of third parties which may result from its use. No license is granted by implication or otherwise under any patent or patent rights of ANALOG SYSTEMS.

## TYPICAL CIRCUITS AND APPLICATIONS

Although the MA-322 is internally compensated, there is an optional external capacitor used for over-compensation under certain conditions. The basic connections:

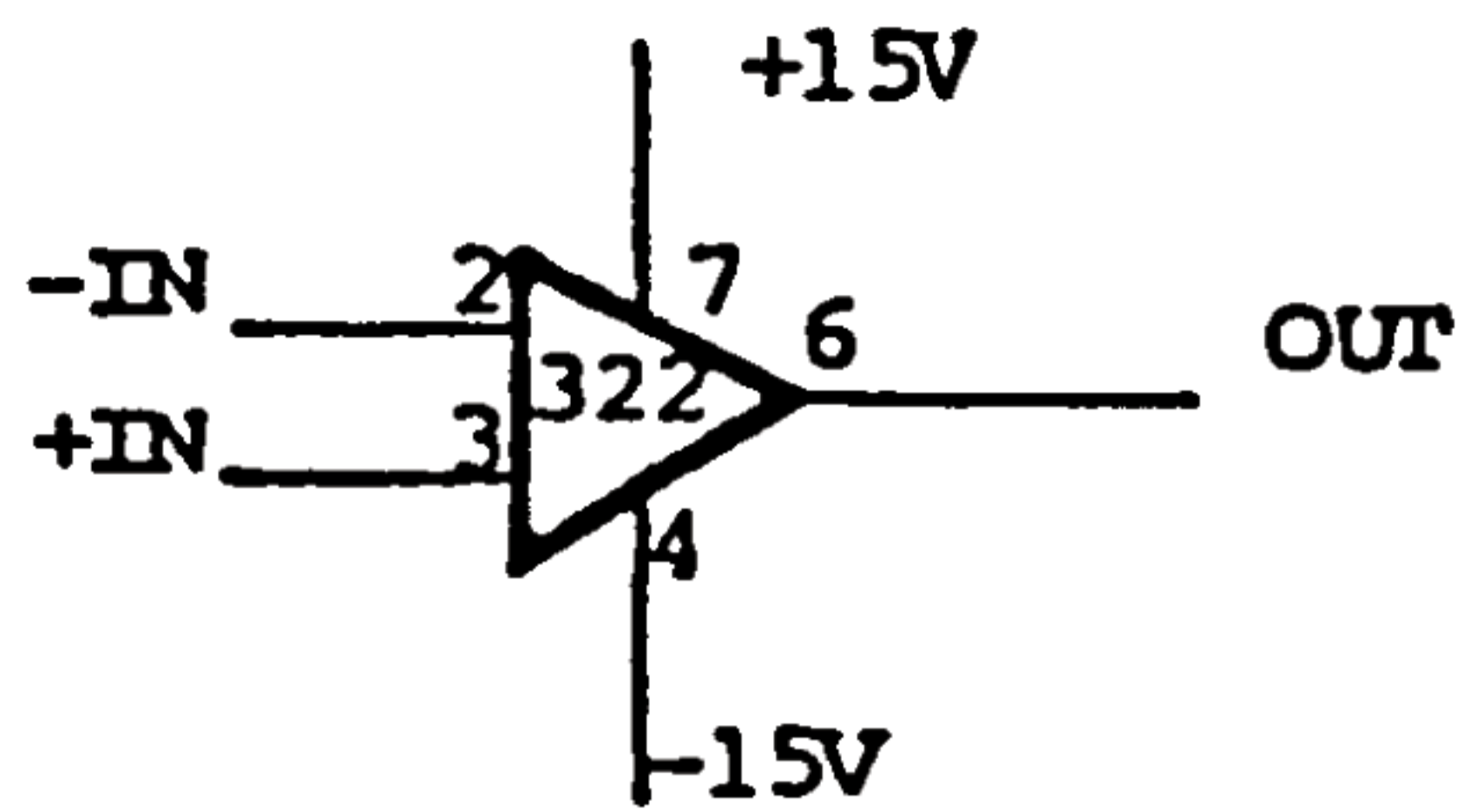

The optional capacitor is connected between pins 5 and 8. A typical value is 33pF.

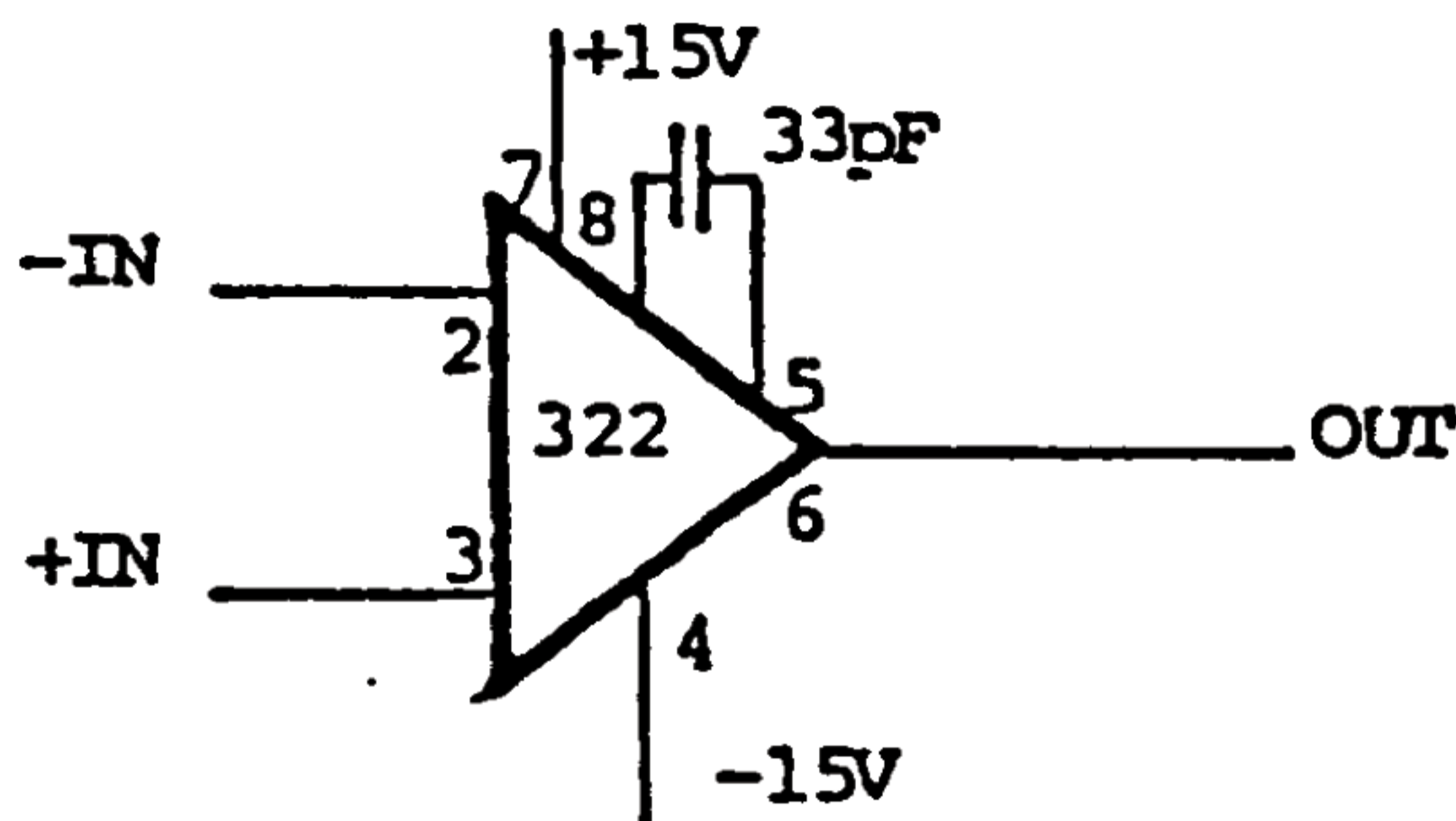

Over-compensation is suggested when MA-322 drives a capacitive load, such as a long cable, or when it is used as an integrator. Two such examples are shown below:

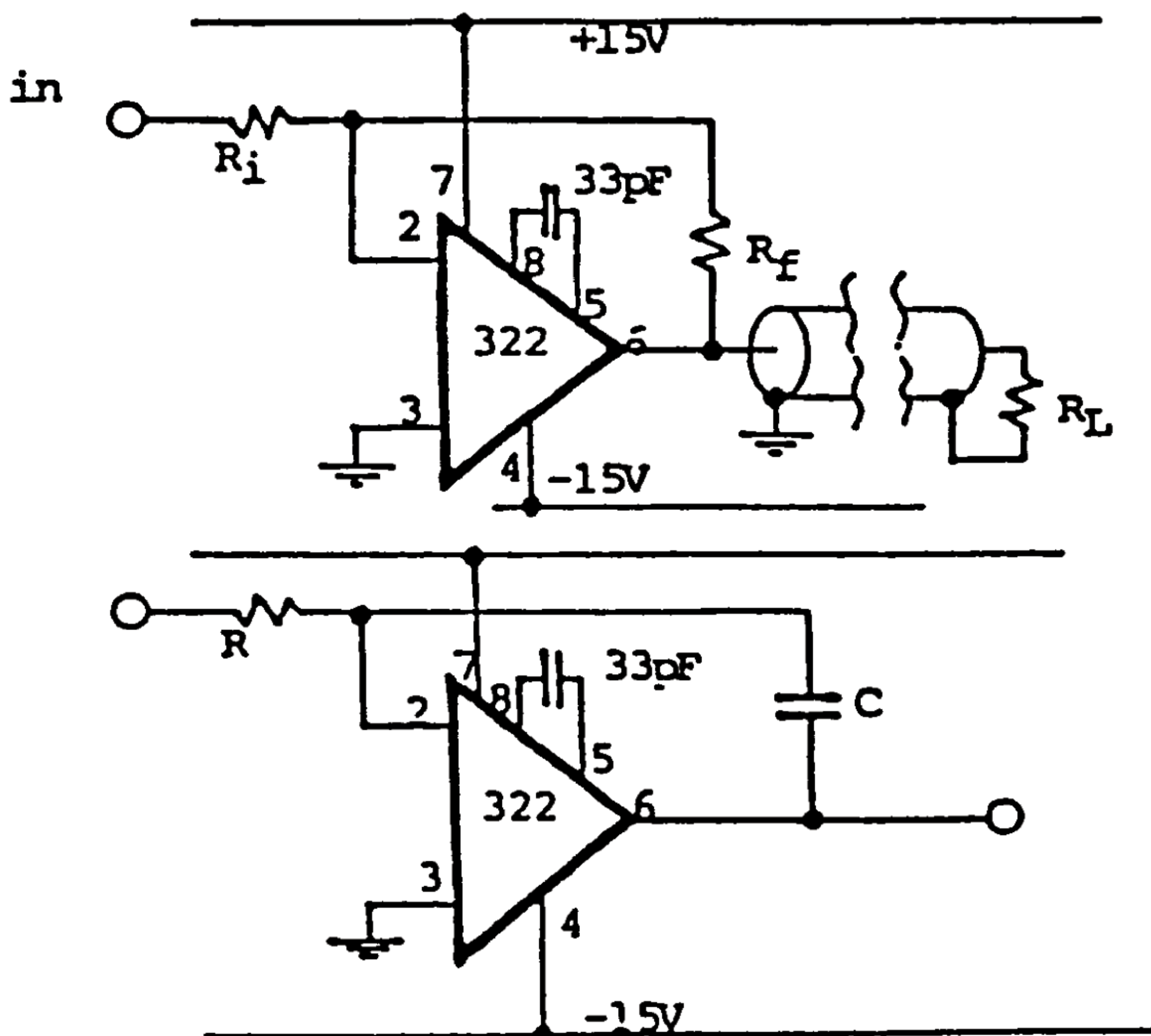

When used with active filters, over-compensation is recommended.

Input current should be limited when overdrive is a possibility. Because protection diodes are used between the differential inputs, excess currents can flow in differentiator and comparator applications. Protection can simply be a resistor in series with one or both inputs.

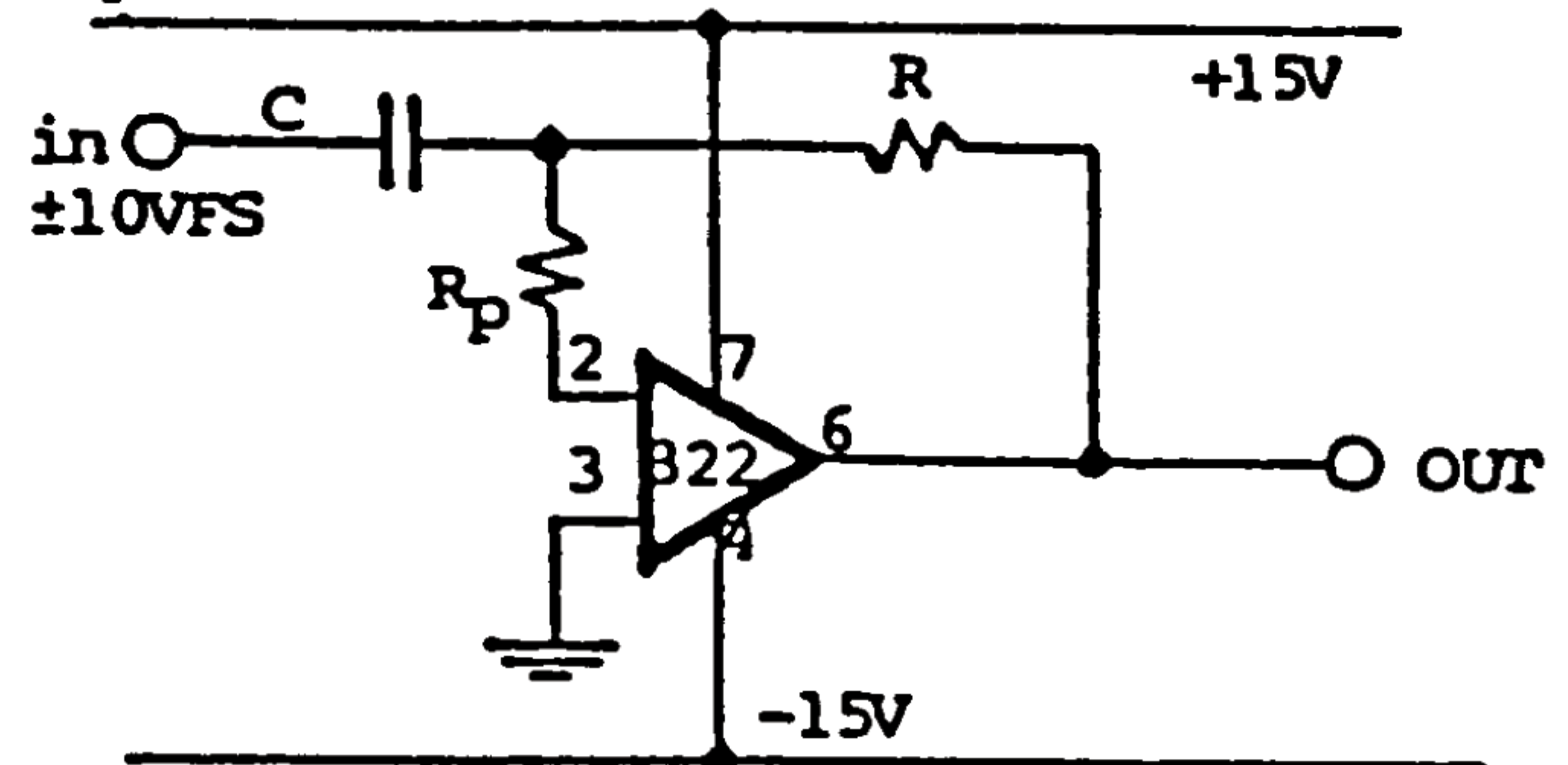

In the above circuit,  $R_p$  is 2k, which limits input current to 5mA, but has no significant effect on circuit operation.

DC offset voltage is nulled with an external potentiometer, as shown. Leads to pins 1 and 8 should be short, because they serve as actual connections to the collectors of the first stage. The use of a resistive trimmer, located within one inch of the MA-322, and away from digital or other switching signal lines is suggested.

