

Megawin

MA101

Datasheet

USB Vendor ID : 0x0E6A

USB Product ID : 0x0103

Index

1	General Description	3
2	Features	4
3	Pin Description	5
4	Application Diagram	6
5	Bridge Function Description	7
5.1	UART Mode	7
5.2	TWSI Mode	9
5.3	SPI Mode	14
5.4	GPIO Mode	18
6	Device Description	19
6.1	Endpoint Description	19
6.2	HID Report Description	19
6.3	Default String Description	20
7	Control Flow	21
8	Application Circuit	22
8.1	MA101 with EEPROM	22
8.2	MA101 without EEPROM	25
9	Absolute Maximum Rating	26
10	DC Characteristics	27
11	AC Characteristics	28
12	Packages	29
12.1	TSSOP28	29
12.2	Package Dimensions	29
13	Revision history	30

1 General Description

MA101 is a driver free USB Data Bridge. It has internal built in UART protocol, SPI master, Two Wire Serial Interface master, GPIO read/write and 3 LED lights which show hardware activities. It also supports external EEPROM connection that can be customized for VID, PID, DID and other Strings. Megawin provides a library in Window environment that makes user to handle MA101 easily.

2 Features

- ◆ Low-speed USB Specification version 1.1 compliance.
- ◆ It is driver free device for Windows 2000, Windows XP, Windows Vista, Windows 7.
- ◆ Support data transfer on UART_TX / UART_RX
 - Baud rate : 4800, 9600, 19200, 38400, 51200*, 57600*, 102400* and 115200*.
 - Parity : Even, Odd, None
 - Stop bit : 1 bit, 1.5 bit, 2 bit
- ◆ Support SPI master.
- ◆ Support Two-Wire-Serial-Interface master.
- ◆ 30 programmable GPIO Port 0/1/2/3/4.
- ◆ LED direct sink pins shared with Port0 (LED 0/1/2/3)
- ◆ Support USB suspend/resume for power management.
- ◆ 6MHz external crystal or ceramic resonator.
- ◆ Built-in 5V to 3.3V regulator for USB.
- ◆ Operating voltage: 4.35V to 5.5V
- ◆ Operating temperature: 0°C to 70 °C
- ◆ Packages : TSSOP28
- ◆ Order Information:

Items	Package Type	IC Marking
MA101-TS28	TSSOP-28	MA101-TS28

Note* : UART transfer is limited by USB Low Speed (1.5Mbps). When user uses baud rate faster than 38400, it must be reference Port 0.0 (Buffer Busy LED) to avoid data loss.

3 Pin Description

PIN Name	Function	I/O	Description
P0.0	BUSY_LED	O	MA101's buffer is busy to receive data from UART (*1)
P0.1	TX/RX_LED	O	MA101 is sending or receiving data with Device (*1)
P0.2	USB_LED	O	MA101 connected with PC successfully (*1)
P0.3~0.5		I/O	Bi-directional I/O
P0.6	UART_TX	I/O	Bi-directional I/O or UART TX function
P0.7	UART_RX	I/O	Bi-directional I/O or UART RX function
P1.0~1.3 P1.6		I/O	Bi-directional I/O
P1.4	SPI_MISO	I/O	Bi-directional I/O or SPI MISO
P1.5	SPI_MOSI	I/O	Bi-directional I/O or SPI MOSI
P1.7	SPI_CLK	I/O	Bi-directional I/O or SPI CLK
P2.1 P2.4~P2.7		I/O	Bi-directional I/O
P2.2	EE_SDA	I/O	Bi-directional I/O or Customer ID EEPROM SDA
P2.3	EE_SCL	I/O	Bi-directional I/O or Customer ID EEPROM SCL
P3.0~3.3 P3.5, P3.6		I/O	Bi-directional I/O
P3.4	TWSI_SDA	I/O	Bi-directional I/O or TWSI SDA
P3.7	TWSI_SCL	I/O	Bi-directional I/O or TWSI SCL
P4.0~4.1 *2		I/O	Bi-directional I/O
RESB		I	Reset pin
XTAL1		I	6MHz crystal or resonator in
XTAL2		O	6MHz crystal or resonator out
DP		I/O	USB data +
DM		I/O	USB data -
VCC		I	Voltage supply
VSS		I	Ground
V3.3		O	3.3V regulated output, a 1uF(min) capacitor should be added on this pin

(*1) P0.0~0.3 can be used to sink LED directly (without any external resistor).

4 Application Diagram

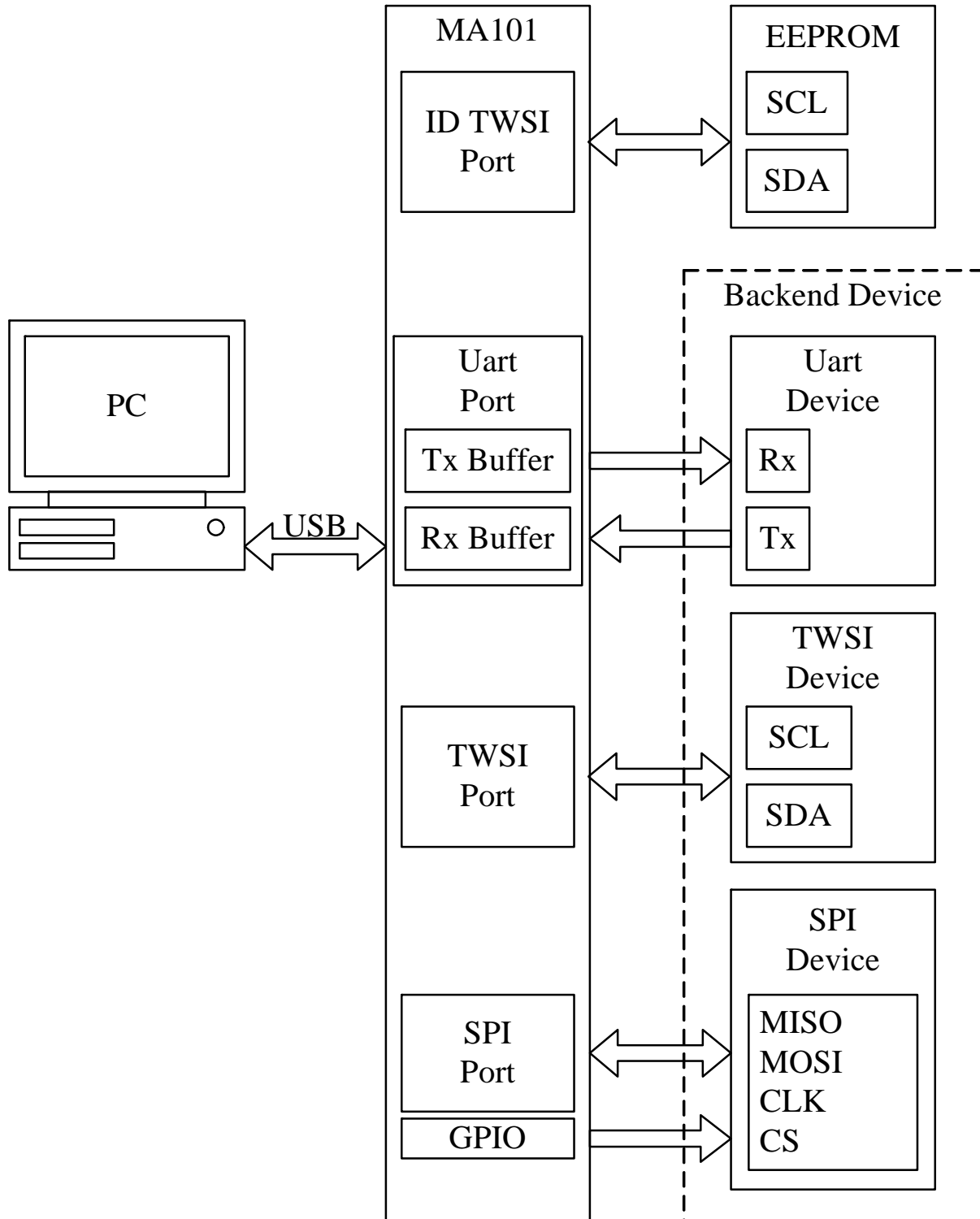

5 Bridge Function Description

MA101's default mode is UART with the setting of Baud rate 4800, Even Parity Check and StopBit of 2. User can use MA101_SetMode() function to change mode type or different mode setting in the BirdgeMini.DLL.

5.1 UART Mode

5.1.1 Feature

MA101 provides UART function as follow:

- ◆ Baud Rate : 4800, 9600, 19200, 38400, 51200, 57600, 102400 and 115200.
- ◆ Parity : None, Even and Odd
- ◆ Stop Bit : 1 bit, 1.5 bit and 2 bit

5.1.2 Initial and GPIO setting

When switch to UART Mode, Port 0.6 is UART_TX, initial setting is Open drain Output. Port 0.7 is UART_RX, initial setting is high Impedance Input.

Initial Table as follow, others unchanged:

PIN	Function	Input/Output	CMOS/NMOS	Pull High Resistor Enable/Disable	Output Buffer
P0.6	UART_TX	Output	Unchanged	Unchanged	High
P0.7	UART_RX	Input	Unchanged	Unchanged	Unchanged

User can use MA101_SetIO_T(), MA101_SetIO_M(), and MA101_SetIO_V() function call in BridgeMini.DLL to change GPIO setting as desired. Beware that during the data transmission, it is recommend not to Set Mode; otherwise data might be lost. Also, before any data transmission, be sure the corresponding circuit environment is built up.

When switch to UART Mode, the I/O configurations are allowed as follow:

This document information is the intellectual property of Megawin Technology Co., Ltd.
© Megawin Technology Co., Ltd. 2009 All rights reserved.

PIN	Input/Output	CMOS/NMOS	Pull High Resistor Enable/Disable	Output Buffer
P0.0	Output	CMOS	Disable	BUSY_LED
P0.1	Output	CMOS	Disable	TX/RX_LED
P0.2	Output	CMOS	Disable	USB_LED
P0.3	Output	CMOS	Disable	VCC
P0.4 , P0.5	User Control	User Control	User Control	User Control
P0.6	User Control	User Control	User Control	UART_TX / User Control Note (1)
P0.7	Input	User Control	User Control	None
P1.0 ~ P1.7	User Control	User Control	User Control	User Control
P2.0	User Control	Note(2)	Note(2)	User Control
P2.1 ~ P2.2	Note(2)	Note(2)	Note(2)	Note(2)
P2.3	User Control	Note(2)	Note(2)	User Control
P2.4 ~ P2.7	User Control	User Control	User Control	User Control
P3.0 ~ P3.7	User Control	User Control	User Control	User Control
P4.0 ~ P4.1	User Control	User Control	User Control	User Control

Note (1): User can set UART_TX to 0 or 1 by MA101_SetIO_V() for special application. It is recommended not to call MA101_SetIO_V() function during the data transmitting; otherwise, the result is undefined. MA101 will reset UART_TX to 1 before transferring any data through WriteData() api, and it keeps 1 after data is completed.

Note (2): If there is an EEPROM with Customer's ID Data, user can't change any setting on Port 2.1 and Port 2.2 by DLL Function Library. The setting includes Input/Out, CMOS/NMOS, Pull High Resistor Enable/Disable and Output Value. On the contrary, if there is no EEPROM, Port 2.1 and Port 2.2 are free to change by user.

5.1.3 Buffer Busy Indicator

When MA101 Data Rx Buffer is near full, Port 0.0 (Busy LED) will change to LOW, remind DUT slow down or stop transfer data to MA101; otherwise, MA101 Rx Data Buffer will overrun. Port 0.0 (Busy LED) will return to HIGH when MA101 Rx Buffer is not busy and safe to continue receive data from Backend Device.

Note: Under certain circumstances, if system resources are not available, it is necessary to reference P0.0 (busy pin) to avoid the data lost.

5.1.4 Port Change Report

At UART mode, if Port 0.6 or Port 0.7 changes, it does not generate Port Change Report. It means it will not detect 1 on the return value at Port 0.6 or Port 0.7 on the MA101_GetPortStatus() function.

5.2 TWSI Mode

5.2.1 Feature

MA101 support 2 interfaces of Two-Wire-Serial-Interface master. User can change data rate as desired. One of interface for EEPROM access, another is for user application. User can use MA101_SetMode() function call in BridgeMini.DLL to change TWSI data rate setting as desired. Recommend user use this interface in single master system.

5.2.2 Initial and GPIO Setting

When switch to TWSI Mode, different number for bus will initial different bus. Initial setting is Output and release HIGH on BUS.

Initial Table as follow, others unchanged:

Bus No.	PIN	Function	Input/Output	CMOS/NMOS	Pull High Resistor Enable/Disable	Output Buffer
0	P3.4	TWSI_SDA	Output	Unchanged	Unchanged	High
	P3.7	TWSI_SCL	Output	Unchanged	Unchanged	High
1	P2.1	ID_SCL	Output	Unchanged	Unchanged	High
	P2.2	ID_SDA	Output	Unchanged	Unchanged	High

User can use MA101_SetIO_T(), MA101_SetIO_M(), and MA101_SetIO_V() function call in BridgeMini.DLL to change GPIO setting as desired. Beware that during the data transmission, it is recommend not to Set Mode; otherwise data might be lost. Also, before any data transmission, be sure the corresponding circuit environment is built up.

When switch to TWSI Mode, the I/O configurations are allowed as follow:

PIN	Input/Output	CMOS/NMOS	Pull High Resistor Enable/Disable	Output Buffer
P0.0	Output	CMOS	Disable	VCC
P0.1	Output	CMOS	Disable	TX/RX_LED
P0.2	Output	CMOS	Disable	USB_LED
P0.3	Output	CMOS	Disable	VCC
P0.4 ~ P0.7	User Control	User Control	User Control	User Control
P1.0 ~ P1.7	User Control	User Control	User Control	User Control
P2.0	User Control	Note	Note	User Control
P2.1 ~ P2.2	Note	Note	Note	Note
P2.3	User Control	Note	Note	User Control
P2.4 ~ P2.7	User Control	User Control	User Control	User Control
P3.0 ~ P3.3	User Control	User Control	User Control	User Control
P3.4	User Control	User Control	User Control	TWSI_SDA
P3.5 , P3.6	User Control	User Control	User Control	User Control
P3.7	User Control	User Control	User Control	TWS_SCL
P4.0 ~ P4.1	User Control	User Control	User Control	User Control

Note: If there is an EEPROM with Customer's ID Data, user can't change any setting on Port 2.1 and Port 2.2 by DLL Function Library. The setting includes Input/Out, CMOS/NMOS, Pull High Resistor Enable/Disable and Output Value. On the contrary, if there is no EEPROM, Port 2.1 and Port 2.2 are free to change by user.

5.2.3 TWSI Setting and Data Flow

User can use MA101_SetMode() function call in BridgeMini.DLL to change TWSI data rate setting as desired.

Parameter definition in TWSI

TWSI_Info	0 : Use TWSI_SDA / TWSI_SCL 1 : Use ID_SDA / ID_SCL
Device_Address	0x00~0x7F
Clock_Rate	0x00~0xFF for clock period

Note : EEPROM slave address must be 0x50.

5.2.4 TWSI AC Electrical Characteristics

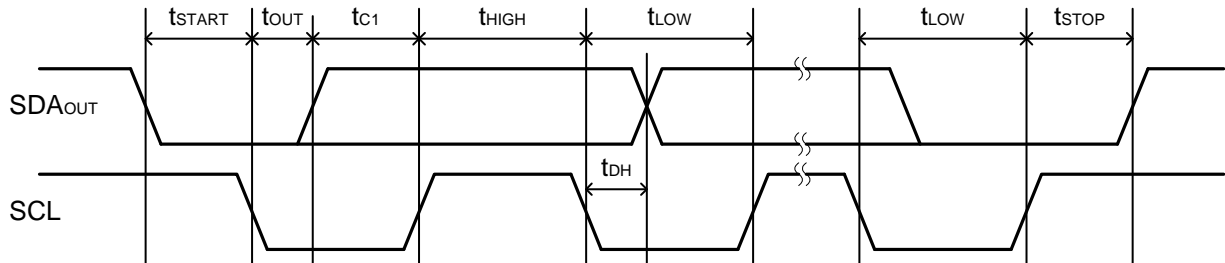

Figure 5-1 : TWSI Start, Stop and Write diagram

TWSI START/STOP

Clock Parameter	START (t_{START})	STOP (t_{STOP})
0x00	12.0 us	11.8 us
0x01	13.2 us	13.2 us
0x02	15.0 us	14.9 us
0x03	16.6 us	16.6 us
0x04	18.2 us	18.2 us
...		
0xFF	440 us	440 us

Note: This parameter is characterized but not 100% tested.

TWSI Write Data

Clock Parameter	Clock High Period (t_{HIGH})	Clock Low Period (t_{LOW})	Clock to Output (t_{OUT})	Data Out to Clock 1 (t_{C1})	Data Out Hold Time (t_{DH})
0x00	10 us	10 us	9.2 us	5 us	4.4~4.8 us
0x01	11.4~11.6 us	11.2 us	9.2 us	6.6 us	4.4~4.8 us
0x02	13.0~13.2 us	12.8~13.0 us	9.2 us	8.2 us	4.4~4.8 us
0x03	14.8~15.0 us	14.6 us	9.2 us	9.8 us	4.4~4.8 us
0x04	16.4 us	16.4 us	9.2 us	11.6 us	4.4~4.8 us
...					
0xFF	436 us	436 us	9.2 us	432 us	4.4~4.8 us

Note: This parameter is characterized but not 100% tested.

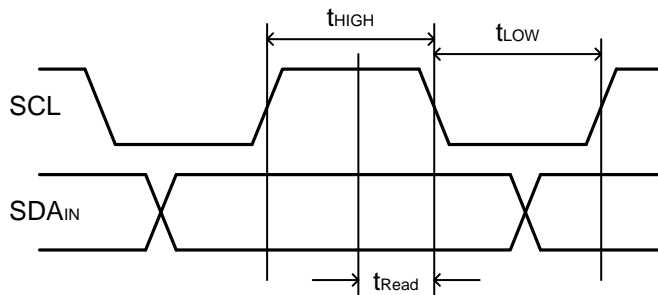

Figure 5-2 : TWSI Read diagram

TWSI Read Data

Clock Parameter	Clock High Period (tHIGH)	Clock Low Period (tLOW)	Data Read (tRead)
0x00	11.6 us	10.0 us	4.33 us
0x01	13.0 us	11.4 us	4.33 us
0x02	14.6 us	13.0 us	4.33 us
0x03	16.2 us	14.8 us	4.33 us
0x04	17.8 us	16.4 us	4.33 us
...			
0xFF	436 us	436 us	4.33 us

Note: This parameter is characterized but not 100% tested.

Average Clock Rate

Clock Parameter	Clock Period	bps
0x00	20.8 us	48.07K
0x01	23.6 us	42.46K
0x02	26.8 us	37.31K
0x03	30.3 us	33.06K
0x04	33.5 us	29.85K
...		
0xFF	872 us	1.147K

Note: This parameter is characterized but not 100% tested.

Reference AC Electrical Characteristics

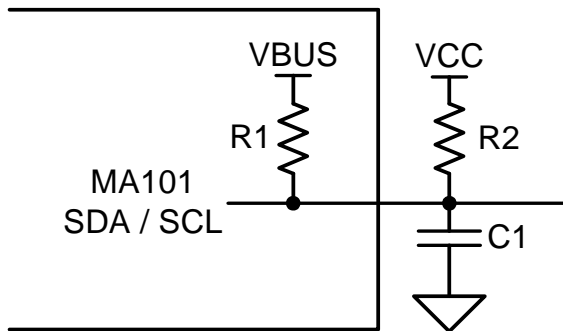

Figure 5-3 : Circuit diagram

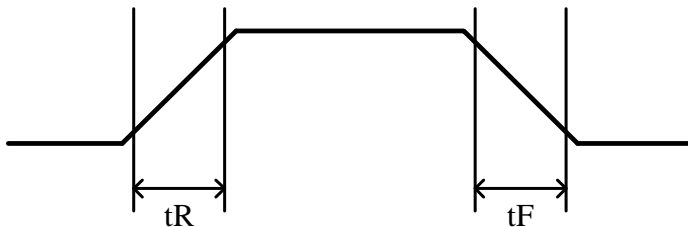

Figure 5-4 : Bus Rising/Falling waveform diagram

SCL/SDA rising time and falling time with internal pull high resistor table

VBUS	Internal Pull High Resistor (R1)	Capacitance (C1)	Rising Time (tR) (10% to 90%)	Falling Time (tF) (90% to 10%)
5.0 V	R1	None	1.64 us	13.2 ns
	R1	47p F	4.05 us	22.1 ns

Note: This parameter is characterized but not 100% tested.

SCL/SDA rising time and falling time with external pull high resistor table:

VCC	External Pull High Resistor (R2)	Capacitance (C1)	Rising Time (tR) (10% to 90%)	Falling Time (tF) (90% to 10%)
5.0V	4.7K Ohm	None	0.28 us	13.7 ns
	4.7K Ohm	47p F	0.73 us	22.1 ns
3.3 V	4.7K Ohm	None	0.29 us	12.5 ns
	4.7K Ohm	47p F	0.76 us	20.7 ns

Note: This parameter is characterized but not 100% tested.

5.2.5 Port Change Report

At TWSI mode, if Port 3.4 or Port 3.7 changes, it does not generate Port Change Report. It means it will not detect 1 on the return value at Port 3.4 or Port 3.7 on the MA101_GetPortStatus() function.

5.3 SPI Mode

5.3.1 Feature

MA101 provides SPI function as follow:

- ◆ Data transmitted first : LSB / MSB
- ◆ Fetch data on clock : Falling Edge / Rising Edge
- ◆ Clock Idle State : Low / High
- ◆ Clock Rate Parameter

5.3.2 Initial and GPIO Setting

When switch to SPI Mode, Port 1.4 is SPI MISO, initial setting is input. Port 1.5 is SPI MOSI, initial setting is output. Port 1.7 is SPI CLK, initial setting is output.

Initial Table as follow, others unchanged:

PIN	Function	Input/Output	CMOS/NMOS	Pull High Resistor Enable/Disable	Output Buffer
P1.4	SPI_MISO	Input	Unchanged	Unchanged	Unchanged
P1.5	SPI_MOSI	Output	Unchanged	Unchanged	SPI_MOSI
P1.7	SPI_CLK	Output	Unchanged	Unchanged	SPI_CLK

User can use MA101_SetIO_T(), MA101_SetIO_M(), and MA101_SetIO_V() function call in BridgeMini.DLL to change GPIO setting as desired. Beware that during the data transmission, it is recommend not to Set Mode; otherwise data might be lost. Also, before any data transmission, be sure the corresponding circuit environment is built up.

When switch to SPI Mode, the I/O configurations are allowed as follow:

PIN	Input/Output	CMOS/NMOS	Pull High Resistor Enable/Disable	Output Buffer
P0.0	Output	CMOS	Disable	VCC
P0.1	Output	CMOS	Disable	TX/RX_LED
P0.2	Output	CMOS	Disable	USB_LED
P0.3	Output	CMOS	Disable	VCC
P0.4 ~ P0.7	User Control	User Control	User Control	User Control
P1.0 ~ P1.3	User Control	User Control	User Control	User Control
P1.4.	User Control	User Control	User Control	SPI_MISO
P1.5	User Control	User Control	User Control	SPI_MOSI
P1.6	User Control	User Control	User Control	User Control
P1.7	User Control	User Control	User Control	SPI_CLK
P2.0	User Control	Note	Note	User Control
P2.1 ~ P2.2	Note	Note	Note	Note
P2.3	User Control	Note	Note	User Control
P2.4 ~ P2.7	User Control	User Control	User Control	User Control
P3.0 ~ P3.7	User Control	User Control	User Control	User Control
P4.0 ~ P4.1	User Control	User Control	User Control	User Control

Note: If there is an EEPROM with Customer's ID Data, user can't change any setting on Port 2.1 and Port 2.2 by DLL Function Library. The setting includes Input/Out, CMOS/NMOS, Pull High Resistor Enable/Disable and Output Value. On the contrary, if there is no EEPROM, Port 2.1 and Port 2.2 are free to change by user.

5.3.3 SPI Setting and Data Flow

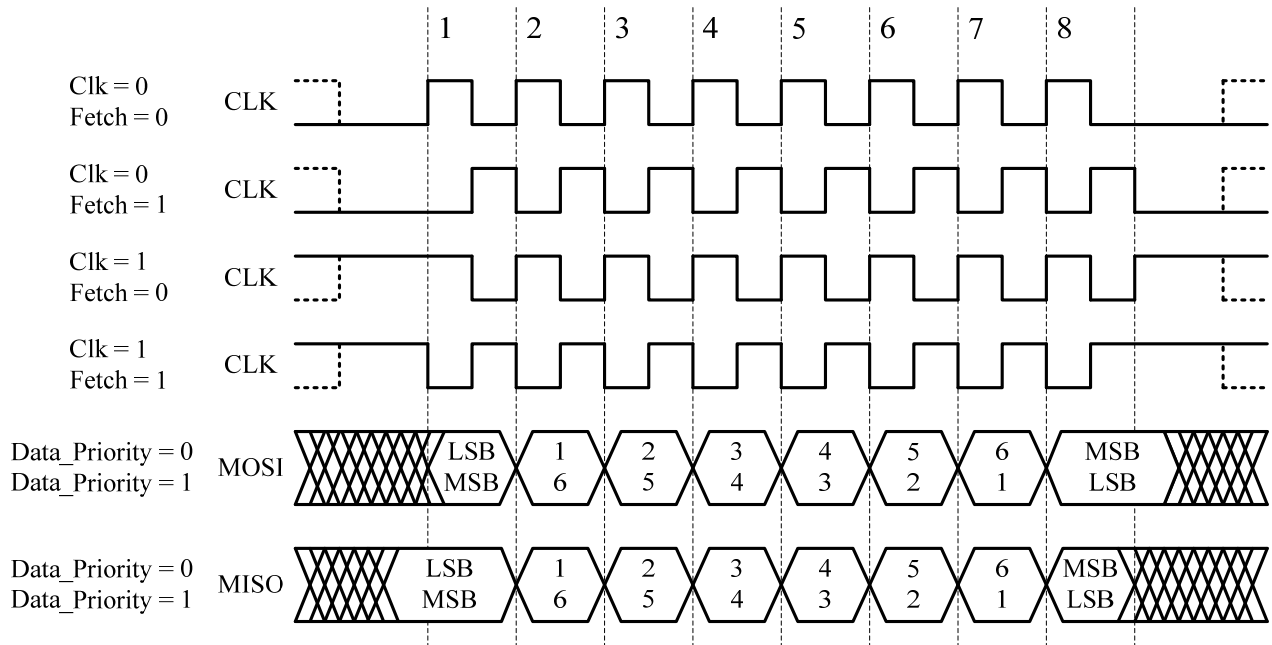

Figure 5-5 : SPI waveform diagram

Parameter definition in SPI

Data_Priority	0 : LSB of data is transmitted first 1 : MSB of data is transmitted first
Fetch	0 : Fetch data on CLK falling 1 : Fetch data on CLK rising
Clk	0 : CLK in LOW when IDLE 1 : CLK in HIGH when IDEL
Clock_Rate	0x00~0xFF for clock period

5.3.4 SPI AC Electrical Characteristics

User can use MA101_SetMode() function call in BridgeMini.DLL to change SPI data rate setting as desired.

Example : Fetch data on CLK falling, Write data on CLK Rising

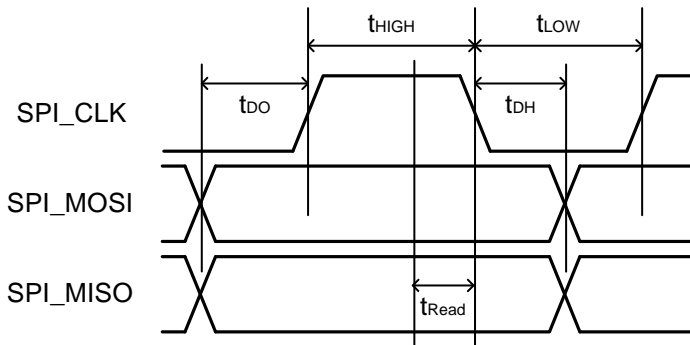

Figure 5-5 : SPI Data Read/Write diagram

SPI AC electrical characteristics

Clock_Rate	Data Out (tDO)	Data Out (tDH)	Data In (tREAD)
0x00	1.7~1.8 us	7.4~7.6 us	4.5~5.1 us
0x01	1.7~1.8 us	8.8 us	4.5~5.1 us
0x02	1.7~1.8 us	10.4~10.6 us	4.5~5.1 us
0x03	1.7~1.8 us	12.2	4.5~5.1 us
0x04	1.7~1.8 us	13.7~13.8 us	4.5~5.1 us
...			
0xFF	1.7~1.8 us	430 us	4.5~5.1 us

Note: This parameter is characterized but not 100% tested.

Average Clock Rate

Clock_Rate	Clock High Period (tHIGH)	Clock Low Period (tLOW)	bps
0x00	9.2 us	9.2 us	54.35K
0x01	10.5 us	10.6 us	47.39K
0x02	12.2 us	12.2 us	40.98K
0x03	13.9 us	13.9 us	35.97K
0x04	15.6 us	15.5 us	32.15K
...			
0xFF	434 us	434 us	1.15K

5.3.5 Port Change Report

At SPI mode, if Port 1.4 or Port 1.5 or Port 1.7 changes, it does not generate Port Change Report. It means it will not detect 1 on the return value at Port 1.4 or Port 1.5 or Port 1.7 on the MA101_GetPortStatus() function.

5.4 GPIO Mode

User can use MA101_SetIO_T(), MA101_SetIO_M(), and MA101_SetIO_V() function call in BridgeMini.DLL to change GPIO setting as desired.

When switch to GPIO Mode, the I/O configurations are allowed as follow:

PIN	Input/Output	CMOS/NMOS	Pull High Resistor Enable/Disable	Output Buffer
P0.0 , P0.1	Output	CMOS	Disable	User Control
P0.2	Output	CMOS	Disable	USB OK
P0.3	Output	CMOS	Disable	User Control
P0.4 ~ P0.7	User Control	User Control	User Control	User Control
P1.0 ~ P1.7	User Control	User Control	User Control	User Control
P2.0	User Control	Note	Note	User Control
P2.1 ~ P2.2	Note	Note	Note	Note
P2.3	User Control	Note	Note	User Control
P2.4 ~ P2.7	User Control	User Control	User Control	User Control
P3.0 ~ P3.1	User Control	User Control	User Control	User Control
P4.0 ~ P4.1	User Control	User Control	User Control	User Control

Note: If there is an EEPROM with Customer's ID Data, user can't change any setting on Port 2.1 and Port 2.2 by DLL Function Library. The setting includes Input/Out, CMOS/NMOS, Pull High Resistor Enable/Disable and Output Value. On the contrary, if there is no EEPROM, Port 2.1 and Port 2.2 are free to change by user.

6 Device Description

6.1 Endpoint Description

MA101 has one Control IN/OUT, one Interrupt IN and one Interrupt OUT. All the MAX packet size is 8 Bytes.

6.2 HID Report Description

Fast Mode

Item	Value(Hex)
Usage Page (Consumer)	0x05, 0x0C
Usage (Remote Control)	0x09, 0x01
Collection (Application)	0xA1, 0x01
Usage (Unassigned)	0x09, 0x00
Logical Minimum (0)	0x15, 0x00
Logical Maximum (1)	0x25, 0x01
Report Size (8)	0x75, 0x08
Report ID (1)	0x85, 0x01
Report Count (1)	0x95, 0x01
Usage (Remote Control)	0x09, 0x01
Feature (Data, Variable, Absolute)	0xB1, 0x02
Report ID (2)	0x85, 0x02
Report Count (2)	0x95, 0x02
Usage (Remote Control)	0x09, 0x01
Feature (Data, Variable, Absolute)	0xB1, 0x02
... (Report ID from 3~62)
Report ID (63)	0x85, 0x3F
Report Count (63)	0x95, 0x3F
Usage (Remote Control)	0x09, 0x01
Feature (Data, Variable, Absolute)	0xB1, 0x02
Report ID (64)	0x85, 0x40
Report Count (7)	0x95, 0x07
Usage (Remote Control)	0x09, 0x01
Input (Data, Variable, Absolute)	0x81, 0x02
Usage (Remote Control)	0x09, 0x01
Output (Data, Variable, Absolute)	0x91, 0x02
End Collection	0xC0

6.3 Default String Description

Manufacturer String : "Megawin Technology Co., Ltd."

Product String : "MA101-USB Bridge"

7 Control Flow

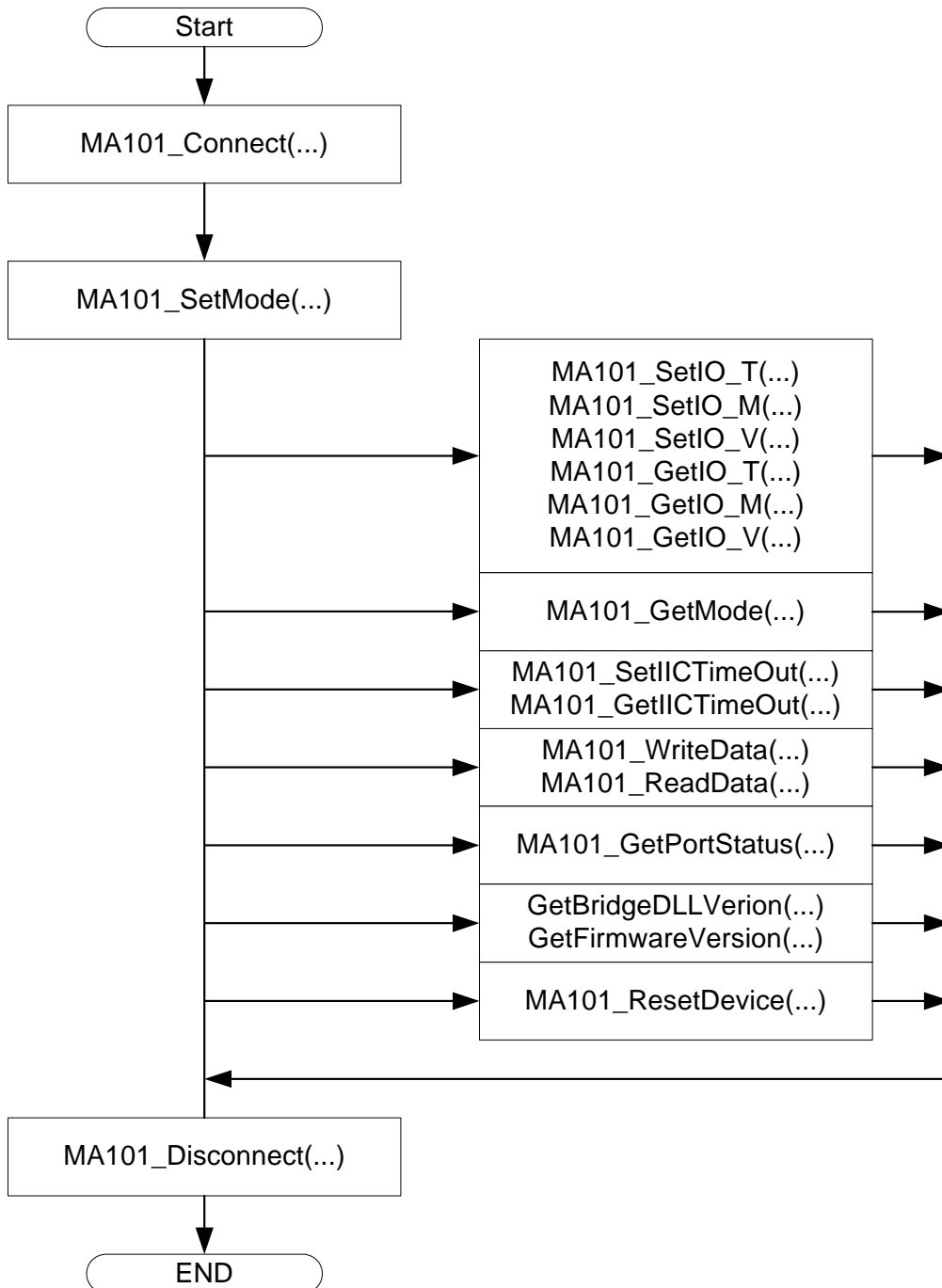

8 Application Circuit

8.1 MA101 with EEPROM

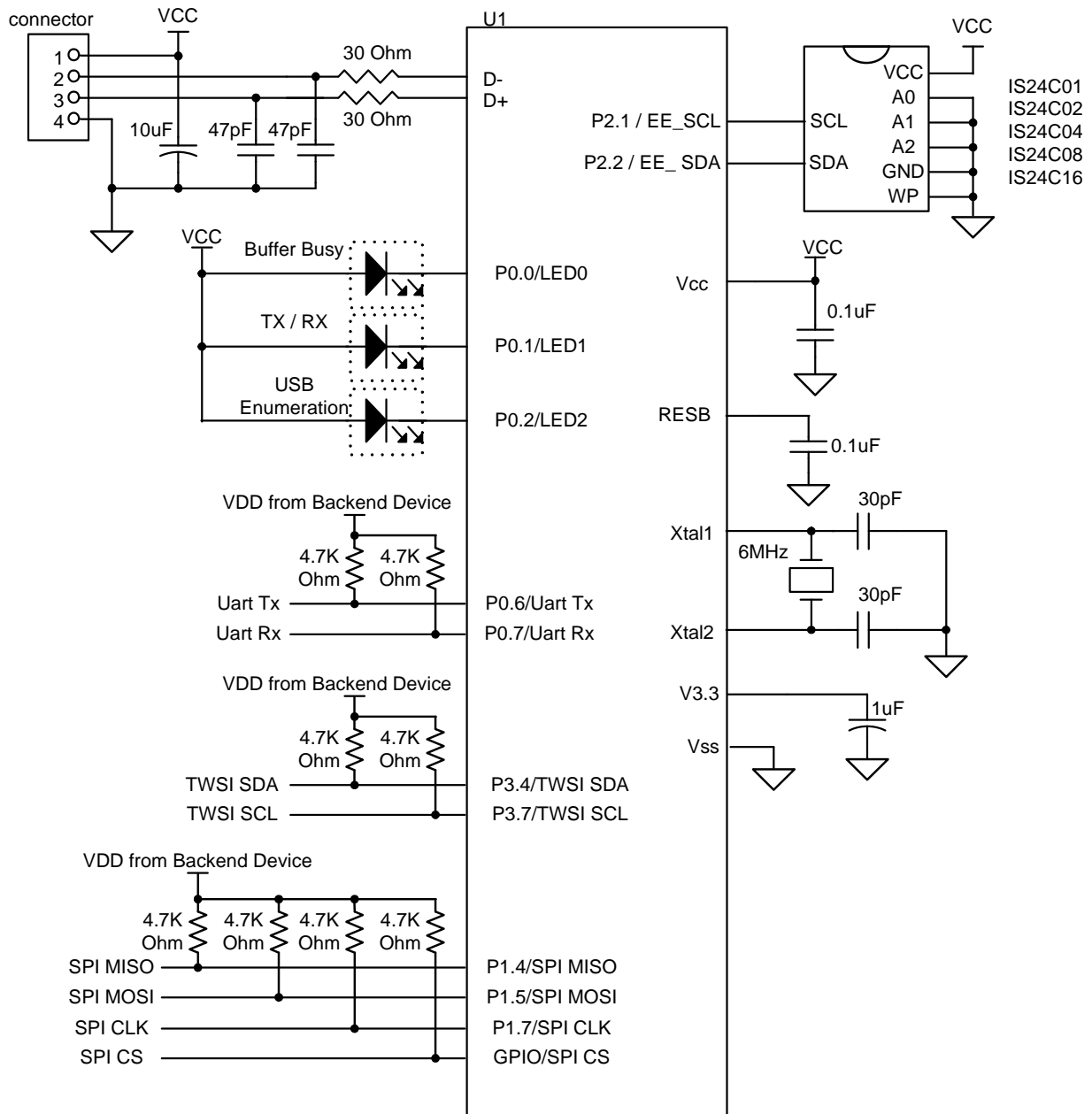

8.1.1 EEPROM Data format

Address (Hex)	Bytes	Item
0x00 ~ 0x01	2	Signature (0x5A, 0xA5)
0x02 ~ 0x13	18	Device Descriptor
0x14 ~ 0x17	4	Language ID
0x18 ~ 0x37	32	Serial Number String
0x38 ~ 0x77	64	Product String
0x78 ~ 0xFF	136	Manufacture String

Note: Signature data must be (**0x5A, 0xA5**).

8.1.2 MA101 Read EEPROM

EEPROM slave address must be 0x50.

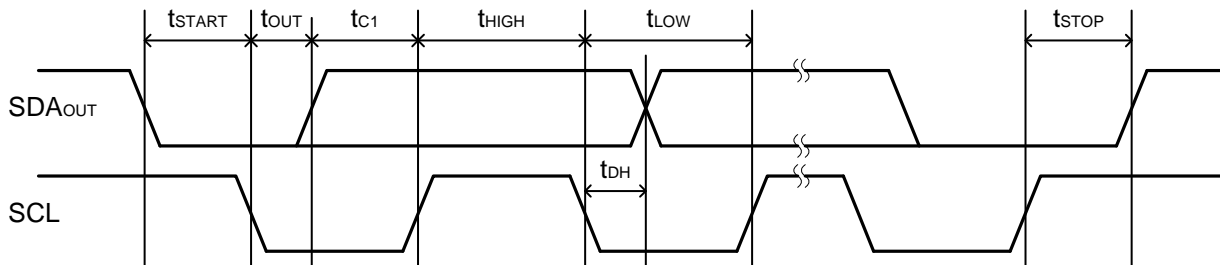

Data Write

Item	Time
Start Hold Time (t_{START})	1.7 us
STOP Hold Time (t_{STOP})	2.32 us
Clock High Period (t_{HIGH})	2.3~2.4 us
Clock Low Period (t_{LOW})	3.4~3.6 us
Clock to Output (t_{OUT})	2.2 us
Data Out to Clock 1 (t_{c1})	1.3 us
Data Out Hold Time (t_{DH})	2.3~2.5 us

Note: This parameter is characterized but not 100% tested.

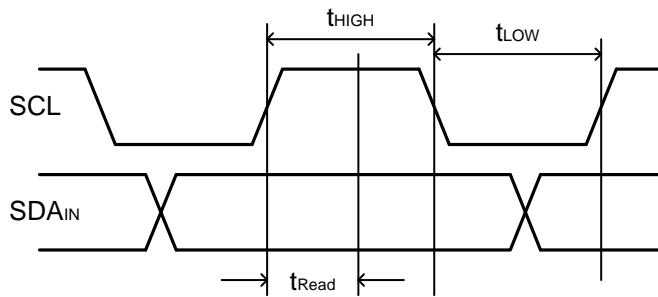

Data Write

Item	Time
Clock High Period (t_{HIGH})	4.0~4.5 us
Clock Low Period (t_{LOW})	1.6~1.7 us
Data Read (t_{READ})	1.5 us

Note: This parameter is characterized but not 100% tested.

8.2 MA101 without EEPROM

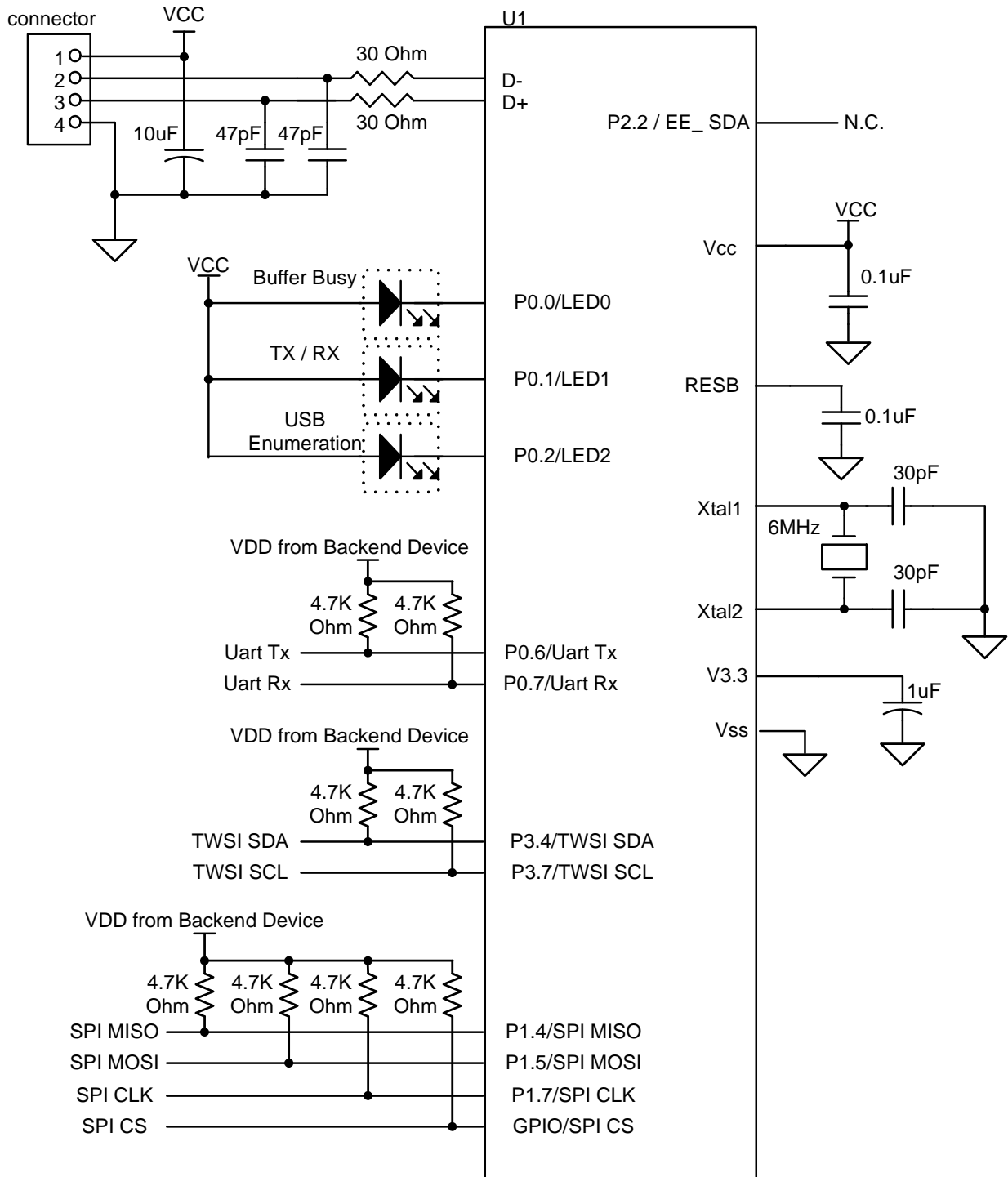

9 Absolute Maximum Rating

Parameter	Rating	Unit
Ambient temperature under bias	-55 ~ +125	°C
Storage temperature	-65 ~ + 150	°C
Voltage on any Port I/O Pin or RST with respect to Ground	-0.5 ~ VCC + 0.5	V
Voltage on VCC with respect to Ground	-0.5 ~ +6.0	V
Maximum total current through VCC and Ground	100	mA
Maximum output current sunk by any Port pin	25	mA

*Note: stresses above those listed under “Absolute Maximum Ratings” may cause permanent damage to the device. This is a stress rating only and functional operation of the devices at those or any other conditions above those indicated in the operation listings of this specification is not implied. Exposure to maximum rating conditions for extended periods may affect device reliability.

10 DC Characteristics

(VCC-VSS = 5.0 V, FOSC = 6MHz, Ta = 25 C; unless otherwise specified)

PARAMETER	SYM.	CONDITIONS	MIN.	TYP.	MAX.	UNIT
Op. Voltage	VCC	-	4.35	-	5.5	V
Op. Current	I _{OP}	No load (Ext.-V) In normal operation	-	-	20	mA
Suspend Current	I _{SUS}	No load (Ext.-V)	-	300	450	A
Input High Voltage	V _{IH}	-	2	-	VCC	V
Input Low Voltage	V _{IL}	-	0	-	0.8	V
Port 0, 1, 2, 3 drive current	I _{OH}	VOH = 4.5V, VDD = 5.0V	-	2.5	-	mA
Port 0.4~0.7, 1, 2, 3 sink current	I _{OL1}	VOL = 0.4V, VDD = 5.0V	-	4.0	-	mA
Port 0.0~0.3 sink current	I _{OL2}	VOL = 3.2V, VDD = 5.0V	6	8	-	mA
Internal Pull-high Resistor	R _{PH}	VIL = 0V	-	27K	-	Ohm
Low Voltage Reset	V _{LVR}			3.25		V

11 AC Characteristics

PARAMETER	SYM.	CONDITIONS	MIN.	TYP.	MAX.	UNIT
POR duration	TPOR	FOSC = 6 MHz	10	-	-	mS

12 Packages

12.1 TSSOP28

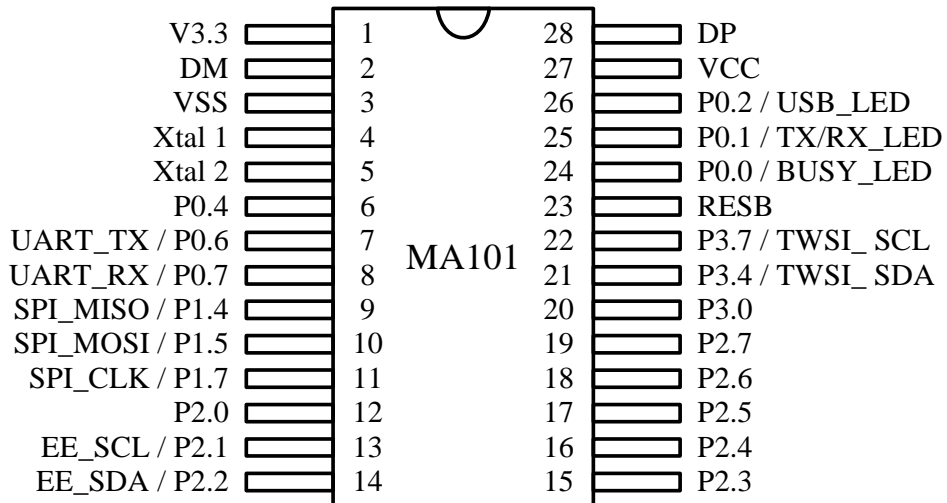

12.2 Package Dimensions

Please, visit Megawin web site under Technical Support->Literature->Package Dimension for the latest package information.

www.megawin.com.tw

13 Revision history

Version	Date	Description
V1.00	2009/09	- Initial version
V1.01	2009/11	- Modify the description of SPI Mode
V1.02	2010/02	- Add "Order Information"