

MEGAWIN

MA108

USB Low Speed Keyboard Target Spec

USB Vendor ID : 0x0E6A

USB Product ID : 0x011B / 0x011C

Contents

1	Description	3
2	Features	4
3	Block Diagram	5
4	Pin Configurations	6
4.1	Pin-out for LQFP48-pin Package	6
4.2	Pad Location	6
4.3	Package Dimensions	6
4.4	Pin Description	7
5	Keyboard Function Description	8
5.1	Feature	8
5.2	Support Key Code Range	9
5.2.1	101 Standard Key	9
5.2.2	Consumer : Usage Page 0C	10
5.2.3	Generic Desktop Control : Usage Page 01	10
5.3	Generic Desktop Control LED Status	10
5.4	Key Matrix	11
5.4.1	Model 0 : Silver Membrane	11
5.4.2	Model 1 : Carbon Membrane	12
6	Reference Design	13
6.1	Model 0 Circuit : Silver Membrane	13
6.2	Model 1 Circuit : Carbon Membrane	14
6.3	Keyboard BOM List	15
6.4	Keyboard EMI Reference	15
6.4.1	Model 0 EMI : Silver Membrane	16
6.4.2	Model 1 EMI : Carbon Membrane	17
7	Electrical Characteristics	18
7.1	DC	18
7.2	USB Transceiver Electrical Characteristics	18
8	Revision History	19

1 Description

The **MA108** is a single chip keyboard encoder. It detects the key is pressed and/or released, sends the scan code to host system, and accepts the command from host system. It also supports the USB standard request version 2.0 as well as HID class request version 1.1.

Megawin Confidential & Proprietary

2 Features

- Support FW recover function for EMS(EFT/ESD)
- Support DFU update 6.5K ROM function
- Low-speed USB Specification version 2.0 compliance.
 - Human Interface Device
 - ✧ Keyboard
 - ✧ Generic Desktop Controls
 - ✧ Consumer
- Support USB suspend/resume for power management.
- Support carbon membrane and silver membrane (P32 pin option).
 - Silver membrane loop resistor must smaller than 2KOhm
 - Carbon membrane loop resistor must smaller than 300KOhm
- LED direct sink pins.
- Built-in 5v to 3.3v regulator.
- Built-in 6Mhz±1.5% oscillator with temperature -40°C ~ 85°C.
- Operating condition:
 - Operating voltage: 2.7V ~ 5.5V with USB on-line application
 - Operating speed range: DC to 6MHz @VDD>2.7V
 - Operating ambient temperature: -40°C ~ 85°C for internal oscillator mode
- Package:
 - LQFP48 : MA108AD48
 - DICE : MA108H
- Support OS : Windows XP / Windows 7 / Windows 8 / BIOS

3 Block Diagram

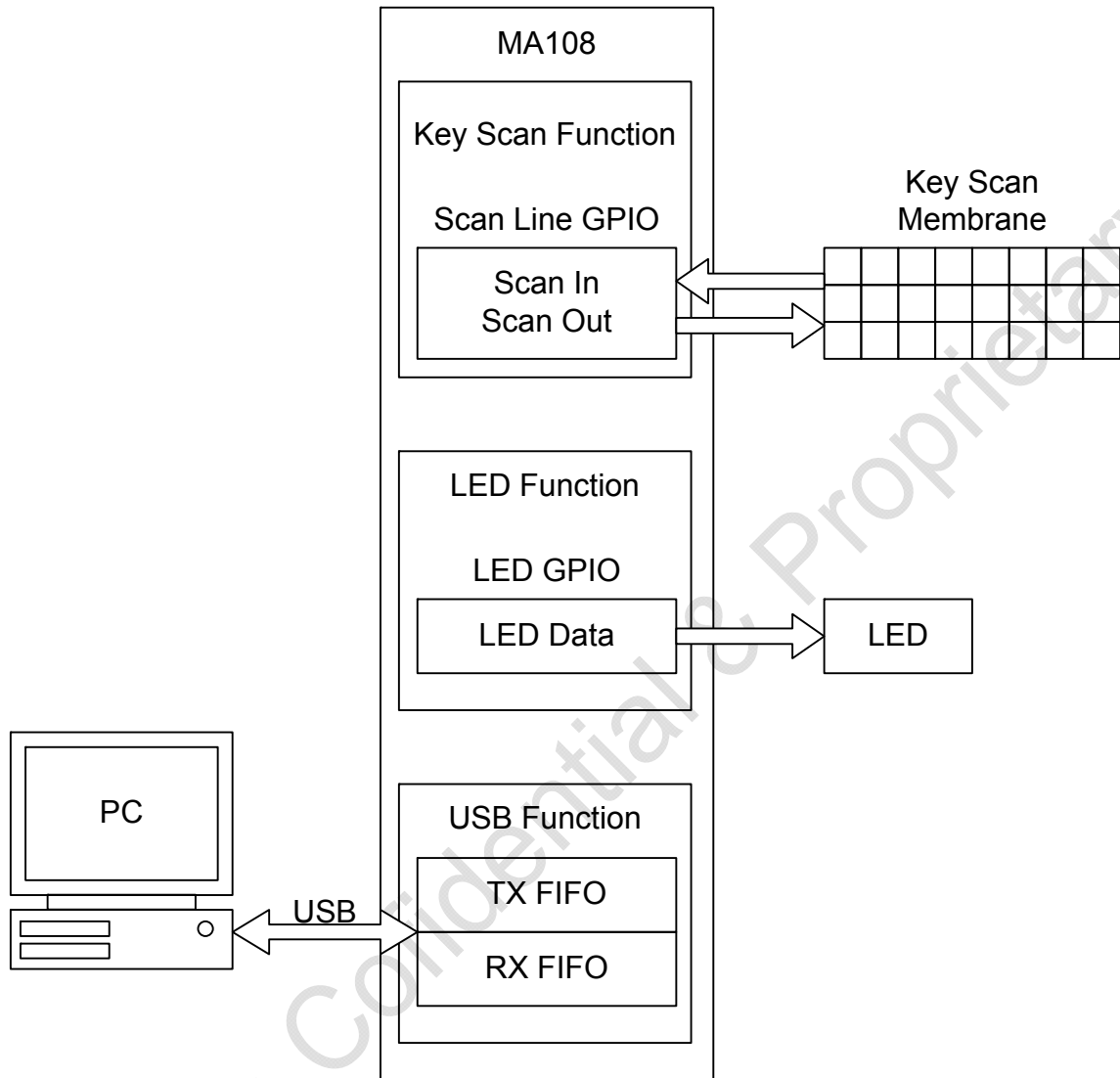
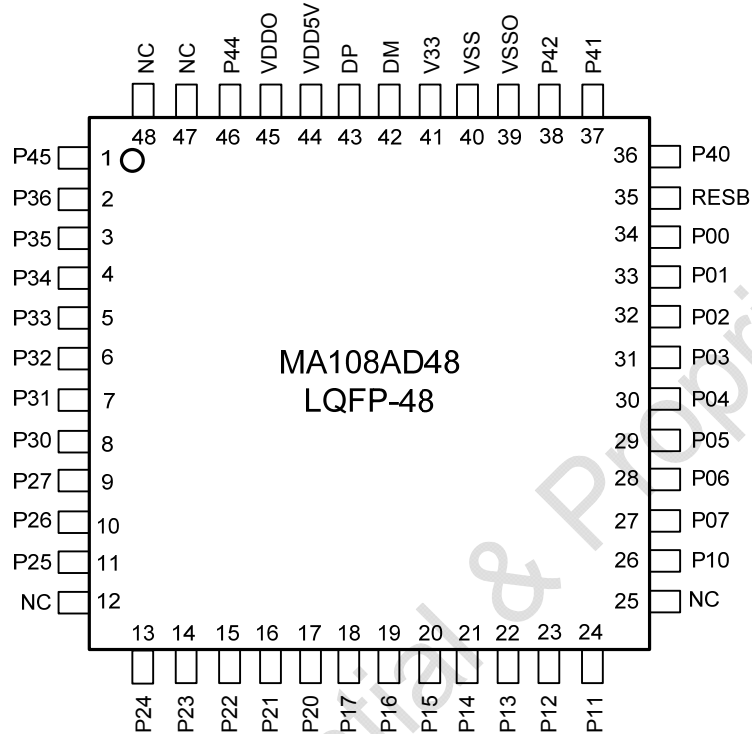

Figure 3-1 Keyboard Diagram

4 Pin Configurations

4.1 Pin-out for LQFP48-pin Package



4.2 Pad Location

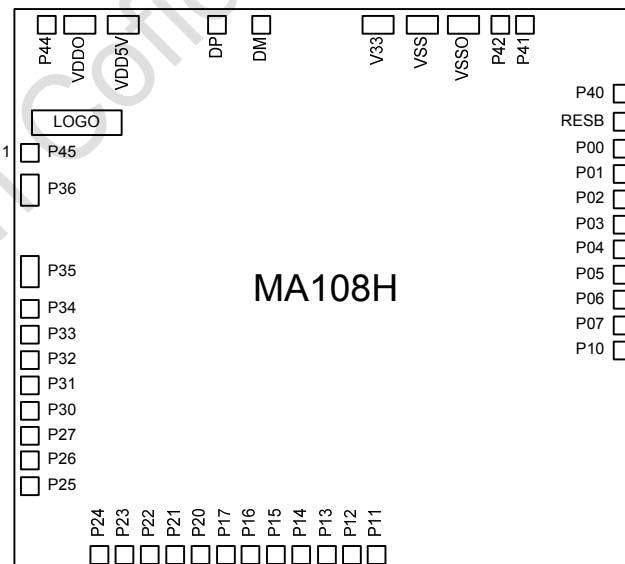

4.3 Package Dimensions

Please, visit Megawin web site under Technical Support->Literature->Package Dimension for the latest package information.

www.megawin.com.tw

4.4 Pin Description

Name	LQFP48	DICE	Type	Description
P36	2	2	B	Reserve
P35	3	3	B	Reserve
P34	4	4	B	Reserve
P33	5	5	B	Model Pin Option M1.
P32	6	6	B	Model Pin Option M0.
P31	7	7	B	Keyboard Scan Out Line 17.
P30	8	8	B	Keyboard Scan Out Line 16.
P27	9	9	B	Keyboard Scan Out Line 15.
P26	10	10	B	Keyboard Scan Out Line 14.
P25	11	11	B	Keyboard Scan Out Line 13.
P24	13	12	B	Keyboard Scan Out Line 12.
P23	14	13	B	Keyboard Scan Out Line 11.
P22	15	14	B	Keyboard Scan Out Line 10.
P21	16	15	B	Keyboard Scan Out Line 9.
P20	17	16	B	Keyboard Scan Out Line 8.
P17	18	17	B	Keyboard Scan Out Line 7.
P16	19	18	B	Keyboard Scan Out Line 6.
P15	20	19	B	Keyboard Scan Out Line 5.
P14	21	20	B	Keyboard Scan Out Line 4.
P13	22	21	B	Keyboard Scan Out Line 3.
P12	23	22	B	Keyboard Scan Out Line 2.
P11	24	23	B	Keyboard Scan Out Line 1.
P10	26	24	B	Keyboard Scan Out Line 0.
P07	27	25	B	Keyboard Scan In Line 7.
P06	28	26	B	Keyboard Scan In Line 6.
P05	29	27	B	Keyboard Scan In Line 5.
P04	30	28	B	Keyboard Scan In Line 4.
P03	31	29	B	Keyboard Scan In Line 3.
P02	32	30	B	Keyboard Scan In Line 2.
P01	33	31	B	Keyboard Scan In Line 1.
P00	34	32	B	Keyboard Scan In Line 0.
RESB	35	33	I	Reset pin, low action, have internal weak pull high resistor.
P40	36	34	B	Number Lock LED directly sink.
P41	37	35	B	Capitals Lock LED directly sink.
P42	38	36	B	Scroll Lock LED directly sink.
VSSO	39	37	G	Ground
VSS	40	38	G	Ground
V33	41	39	P	Regulator pin, a capacitor should be added on this pin.
DM	42	40	B	USB DM I/O, USB LS transceiver.
DP	43	41	B	USB DP I/O, USB LS transceiver.
VDD5V	44	42	P	5V Power
VDDO	45	43	P	5V Power
P44	46	44	B	Reserve
P45	1	1	B	Reserve

Note: In the "Type" field,
 "I" means input only.
 "O" means output only.
 "B" means bi-direction.
 "P" means Power, G means Ground.

5 Keyboard Function Description

5.1 Feature

- USB specification : 2.00
- Vendor ID: 0x0E6A
- Product ID:
 - Silver membrane : 0x011B
 - Carbon membrane : 0x011C
- String Code : 0x0409
 - Manufacturer String : Megawin Technology Co., Ltd.
 - Product String : USB Multi-Media Keyboard
- Max power : 100mA
- Key scan response time
 - Make : 16ms
 - Break : 20ms
- Ghost key detect
- USB Interface for Key Code
 - Interface 0 (Endpoint 1) : 101 Standard Key & Modifier Key (Usage Page 0x07)
 - Interface 1 (Endpoint 2)
 - ◇ Report ID 1 : Consumer (Usage Page 0x0C)
 - ◇ Report ID 2 : Generic Desktop Control (Usage Page 0x01)
- USB Report Rate
 - Interface 0 (Endpoint 1) : period 16ms
 - Interface 1 (Endpoint 2) : period 32ms

5.2 Support Key Code Range

5.2.1 101 Standard Key

Usage Page 07 Table

Key	Usage HID ID	Key	Usage HID ID	Key	Usage HID ID	Key	Usage HID ID
A	04	1!	1E	Caps Lock	39	Num Lock	53
B	05	2@	1F	F1	3A	Pad /	54
C	06	3#	20	F2	3B	Pad *	55
D	07	4\$	21	F3	3C	Pad -	56
E	08	0.05	22	F4	3D	Pad +	57
F	09	6^	23	F5	3E	Pad Enter	58
G	0A	7&	24	F6	3F	Pad 1	59
H	0B	8*	25	F7	40	Pad 2	5A
I	0C	9(26	F8	41	Pad 3	5B
J	0D	0)	27	F9	42	Pad 4	5C
K	0E	Enter	28	F10	43	Pad 5	5D
L	0F	Esc	29	F11	44	Pad 6	5E
M	10	Backspace	2A	F12	45	Pad 7	5F
N	11	Tab	2B	Print Screen	46	Pad 8	60
O	12	Space	2C	Scroll Lock	47	Pad 9	61
P	13	-_	2D	Pause	48	Pad 0	62
Q	14	=+	2E	Insert	49	Pad .	63
R	15	{	2F	Home	4A	APP	65
S	16	}	30	Page Up	4B	Left Ctrl	E0
T	17	\	31	Delete	4C	Left Shift	E1
U	18	::	33	End	4D	Left Alt	E2
V	19	”	34	Page Down	4E	Left Win	E3
W	1A	~	35	→	4F	Right Ctrl	E4
X	1B	,<	36	←	50	Right Shift	E5
Y	1C	.>	37	↓	51	Right Alt	E6
Z	1D	/?	38	↑	52	Right Win	E7

Modifier Data Format

Bit 7	Bit 6	Bit 5	Bit 4	Bit 3	Bit 2	Bit 1	Bit 0
Right Win	Right Alt	Right Shift	Right Ctrl	Left Win	Left Alt	Left Shift	Left Ctrl

5.2.2 Consumer : Usage Page 0C

Function	Make	Break	Function	Make	Break
Scan Next Track	00 B5	00 00	AL Calculator	01 92	00 00
Scan Previous Track	00 B6	00 00	AL Local Machine Browser	01 94	00 00
Stop	00 B7	00 00	AC Search(www)	02 21	00 00
Play / Pause	00 CD	00 00	AC Home(www)	02 23	00 00
Mute	00 E2	00 00	AC Back(www)	02 24	00 00
Volume Increment	00 E9	00 00	AC Forward(www)	02 25	00 00
Volume Decrement	00 EA	00 00	AC Stop(www)	02 26	00 00
AL Consumer Control Configuration	01 83	00 00	AC Refresh(www)	02 27	00 00
AL Email Reader	01 8A	00 00	AC Bookmarks(www)	02 2A	00 00

5.2.3 Generic Desktop Control : Usage Page 01

Function	Make	Break
System Power Down	81	00
System Sleep	82	00
System Wake Up	83	00

5.3 Generic Desktop Control LED Status

Support direction sink LED by GPIO

P40	Number Lock LED directly sink.
P41	Capitals Lock LED directly sink.
P42	Scroll Lock LED directly sink.

5.4 Key Matrix

5.4.1 Model 0 : Silver Membrane

	P00	P01	P02	P03	P04	P05	P06	P07
P10		Right Ctrl		System Power Down	Left Ctrl	System Sleep		
P11	Scroll Lock	2@	~	B	Page Up	}}	1!	Pad *
P12				Left Alt			Right Alt	
P13	Pad Enter	F9	W	F1	F10	Esc	Pad 8	F8
P14	Print Screen	S	F4	F3	↓	Pad 6	System Power Down	
P15	Insert	F12	↑	U	F11	E	I	Pad 4
P16	Pad 7	F6	Pad 5	Play/Pause	A	←	System Sleep	F7
P17		.>	K	{[L	J	F5	
P20	Z	Pad 2	::	F2	-_	N	F	0)
P21	AC Back (www)	AL Email Reader	AC Forward (www)	AC Stop (www)	AC Refresh (www)	Mute	AC Search (www)	Left Win
P22		3#	4\$	G	Q	H	TAB	Pad -
P23	App	End	Pad 0	Caps Lock	Num Lock	Enter	Page Down	Pad /
P24	V	7&	,<	Pad 3	+=	M	8*	9(
P25	Backspace	Pad +	5%	6^	R	T	Y	Home
P26	Right Win	AC Home (www)		AC Bookmarks (www)	Stop		AL Local Machine Browser	AL Calculator
P27	Pause	→	"	D	Pad 1	P	O	/?
P30	Space	Pad 9	Pad .		\\	Delete	X	C
P31	Scan Previous Track	AL Consumer Control Configuration	Left Shift	Volume Increment	System Wake Up	Right Shift	Volume Decrement	Scan Next Track

5.4.2 Model 1 : Carbon Membrane

	P00	P01	P02	P03	P04	P05	P06	P07
P10	~	1!	TAB	Z	Q	A	Esc	
P11	F1	2@	Caps Lock	X	W		S	
P12	Left Ctrl	F5	System Power Down	Right Ctrl	Pause		System Sleep	System Wake Up
P13	Home	End		Play / Pause	Pad +	Pad Enter	↑	←
P14	F8	9(F7	.>	O	L		App
P15	Delete	System Power Down	Pad 4	Num Lock	Pad 7	Pad 1	Space	↓
P16	Insert	System Sleep	Pad 5	Pad /	Pad 8	Pad 2	Pad 0	→
P17	F9	F10	Back←	Enter		\\	F11	F12
P20	-_	0)	{[P	::	"	/?
P21	+ =	8*	}]	,<	I	K	F6	
P22	6^	7&	Y	M	U	J	H	N
P23	5%	4\$	T	V	R	F	G	B
P24	F2	3#	F3	C	E	D	F4	
P25	Page Up	Page Down	Pad 6	Pad *	Pad 9	Pad 3	Pad .	Pad -
P26	Mute	AC Search (www)	Left Win	AC Back (www)	AL Email Reader	AC Forward (www)	AC Stop (www)	AC Refresh (www)
P27	Scan Previous Track	AL Consumer Control Configuration	Left Shift	Volume Increment	System Wake Up	Right Shift	Volume Decrement	Scan Next Track
P30		Print Screen			Scroll Lock		Left Alt	Right Alt
P31	AC Home (www)		AC Bookmarks (www)	Stop		Right Win	AL Local Machine Browser	AL Calculator

6 Reference Design

6.1 Model 0 Circuit : Silver Membrane

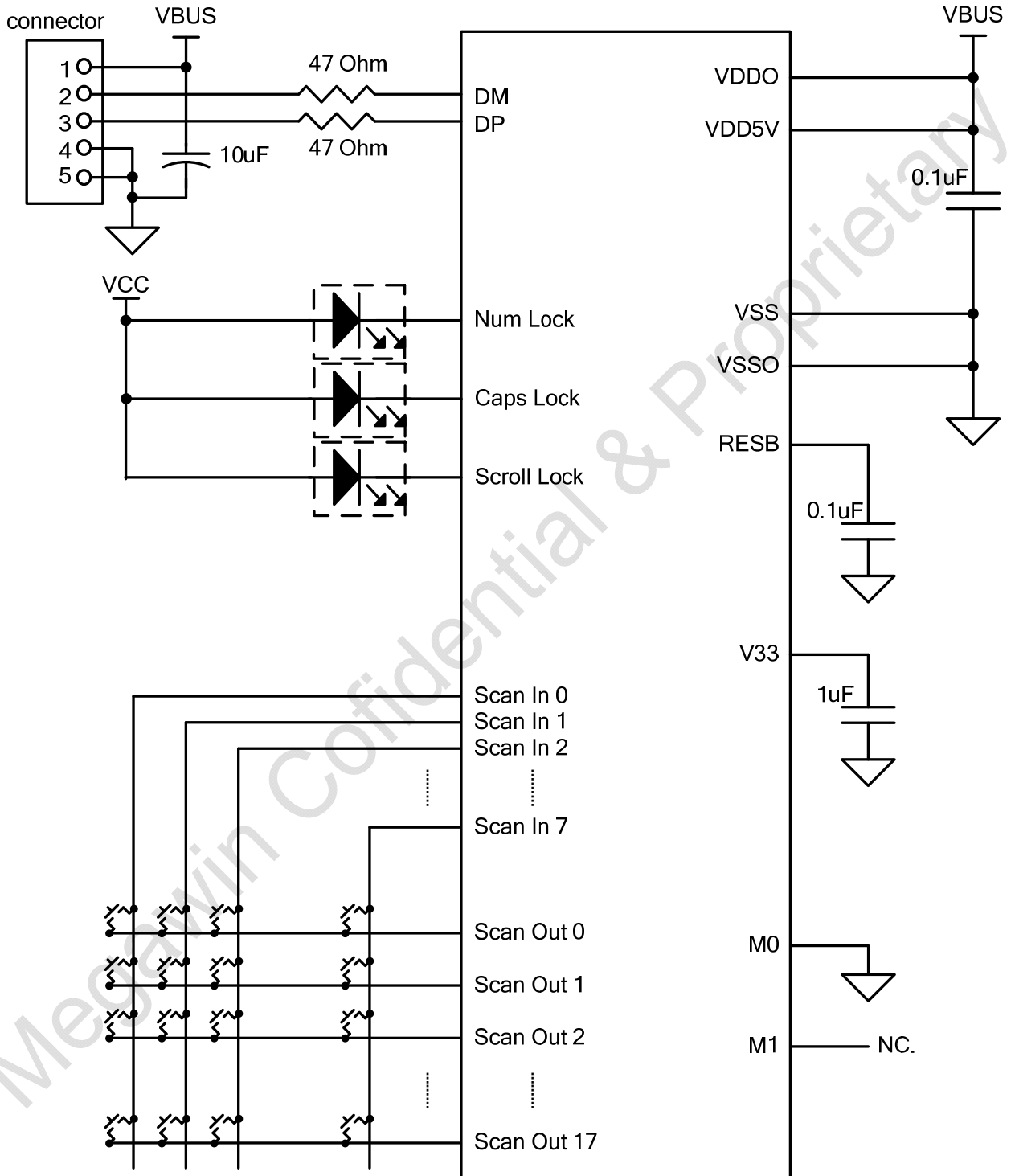

Figure 6-1 Model 0 Circuit : Silver Membrane

6.2 Model 1 Circuit : Carbon Membrane

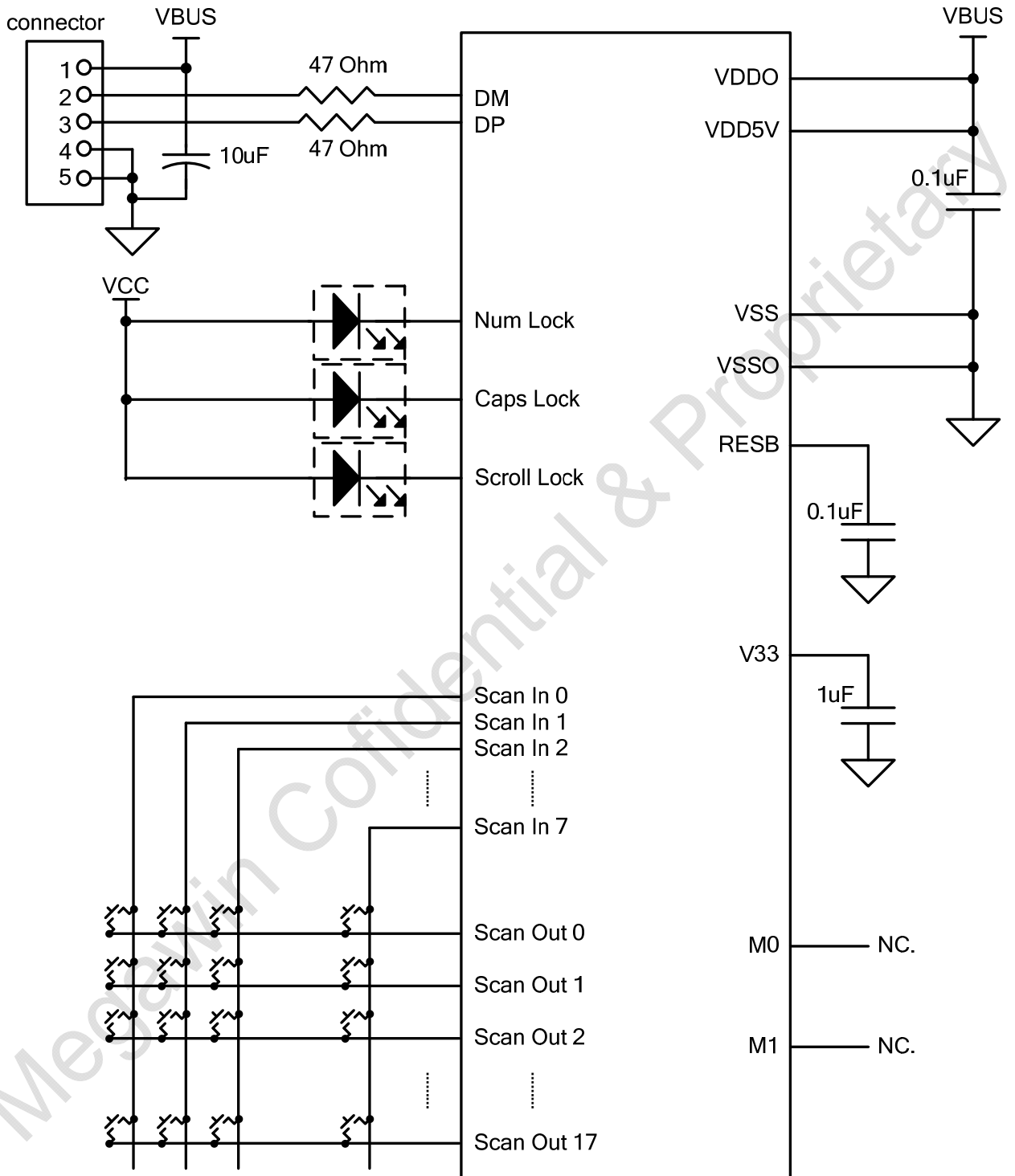

Figure 6-2 Model 1 Circuit : Carbon Membrane

6.3 Keyboard BOM List

Table 6-1 USB Keyboard BOM List

Comment	Pattern	Quantity	Note
MA108	DICE or LQFP48	1	USB HID Keyboard
10u/16V	SMD or DIP	1	VBUS to GND (Near by USB connector)
1u/16V	SMD or DIP	1	V33 to GND (Nearby MA108)
0.1u/16V	SMD or DIP	2	RESB to GND VBUS to GND (Nearby MA108)
LED-G	SMD or DIP	3	LED GRN 17-21VGC/TR8 VR5V 30mA

6.4 Keyboard EMI Reference

- Lab : CRC TR6 3M RE CHAMBER
- EUT : PC(110V) and USB Keyboard
- Keyboard PCB Layout
 - Single Layer (CEM3) : 1.6mm
 - Thick Cu : 1 oz
- Cable without ring core
 - About 1m60cm



- Key-scan : 'H' key press, silver / carbon membrane without VSS shielding
- ALL LED ON.

6.4.1 Model 0 EMI : Silver Membrane

Vertical Test Report

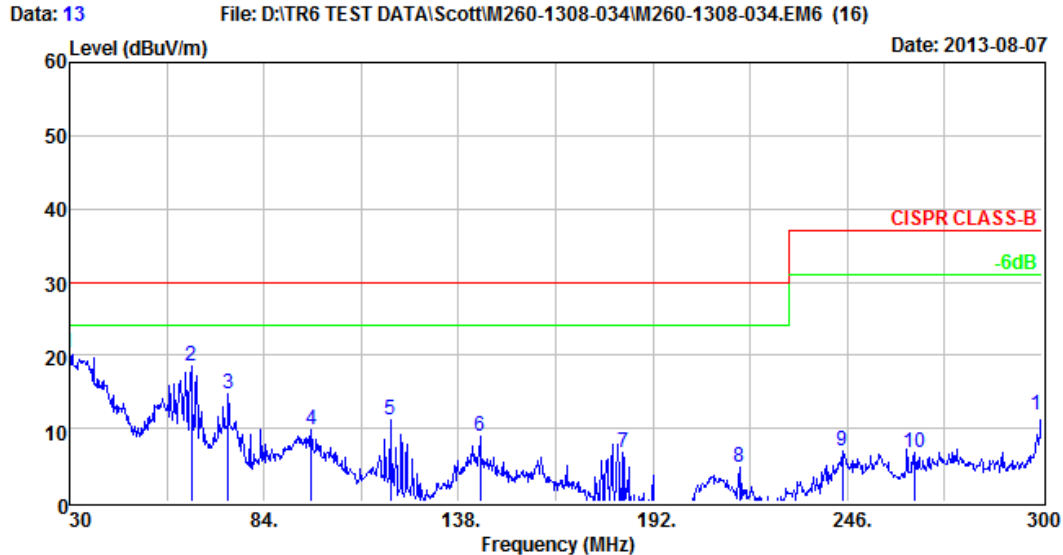

Site : TR 6 (3M 7x3x3 Chamber "非規範"場地，數據僅供參考)
 Condition: CISPR CLASS-B 10m TR6_FACTOR VERTICAL
 eut : Keyboard:MG64F237 #2_A(K120)
 mode : KEY IN"H"
 Power : 110V/60Hz
 operator : scott
 memo : USE LENOVO PC IN TR6 IN CRC.(96)
 memo : OS:windows XP

Horizontal Test Report

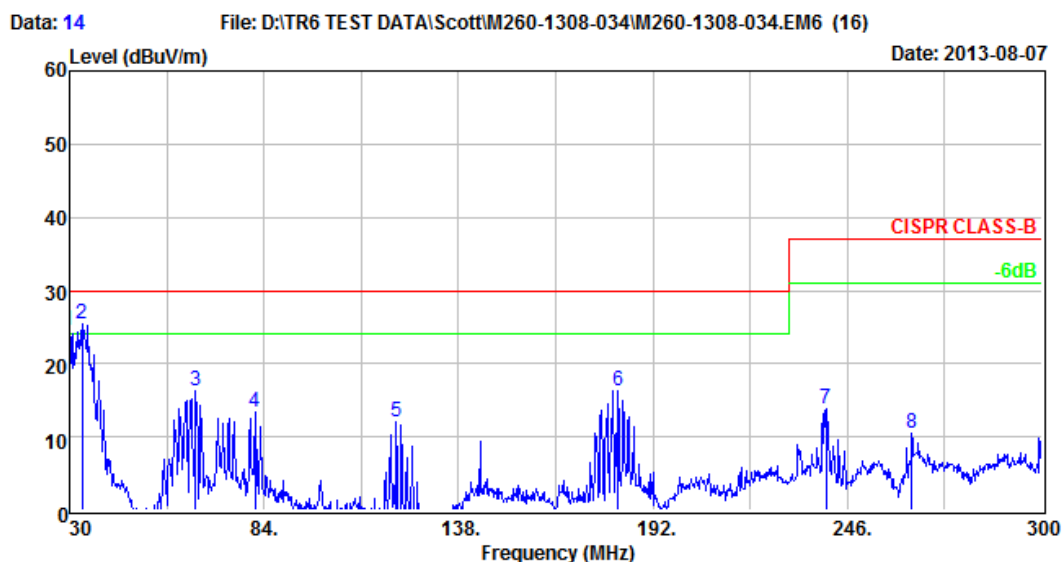

Site : TR 6 (3M 7x3x3 Chamber "非規範"場地，數據僅供參考)
 Condition: CISPR CLASS-B 10m TR6_FACTOR HORIZONTAL
 eut : Keyboard:MG64F237 #2_A(K120)
 mode : KEY IN"H"
 Power : 110V/60Hz
 operator : scott
 memo : USE LENOVO PC IN TR6 IN CRC.(96)
 memo : OS:windows XP

6.4.2 Model 1 EMI : Carbon Membrane

Vertical Test Report

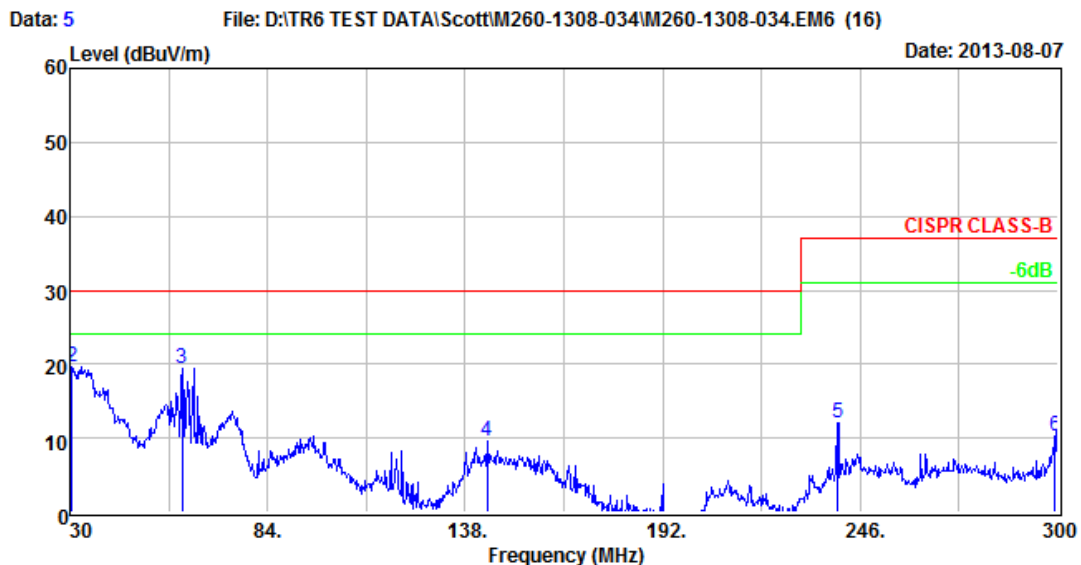

Site : TR 6 (3M 7x3x3 Chamber "非規範"場地，數據僅供參考)
 Condition: CISPR CLASS-B 10m TR6_FACTOR VERTICAL
 eut : Keyboard:MG64F237 #4_A
 mode : KEY IN"H"
 Power : 110V/60Hz
 operator : scott
 memo : USE LENOVO PC IN TR6 IN CRC. (96)
 memo : OS:windows XP

Horizontal Test Report

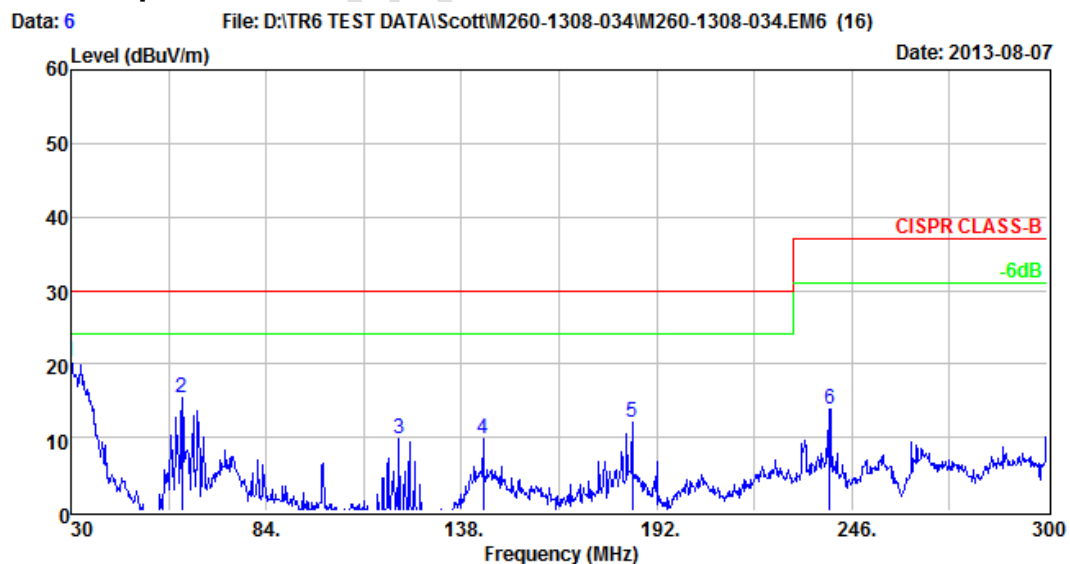

Site : TR 6 (3M 7x3x3 Chamber "非規範"場地，數據僅供參考)
 Condition: CISPR CLASS-B 10m TR6_FACTOR HORIZONTAL
 eut : Keyboard:MG64F237 #4_A
 mode : KEY IN"H"
 Power : 110V/60Hz
 operator : scott
 memo : USE LENOVO PC IN TR6 IN CRC. (96)
 memo : OS:windows XP

7 Electrical Characteristics

7.1 DC

VSS = 0V, TA = 25 °C, VDD5V=VDDO= 5.0V and execute NOP for each machine cycle, unless otherwise specified

Symbol	Parameter	Test Condition	Limits			Unit
			min	typ	max	
V _{IH1}	Input High voltage (All I/O Ports except P35&P36)		2.0			V
V _{IH2}	Input High voltage (RESET)		3.9			V
V _{IL1}	Input Low voltage (All I/O Ports except P35&P36)				0.8	V
V _{IL2}	Input Low voltage (RESET)				1.1	V
I _{OL1}	Output Low current (All I/O Ports except P35&P36)	V _{PIN} = 0.4V		4		mA
I _{OP}	Operating current	F _{OSC} = 6MHz		6		mA
I _{PD}	Power down current			150		uA
R _{RST}	Internal reset pull-down resistance			50		KΩ
R _{DM}	DM pull-up resistance in USB mode			1.1		KΩ
V33	Regulator output voltage			3.3		V
F _{INT}	Built-in oscillator frequency		5.91	6	6.09	MHz
T _{INT}	System initial time			60		ms

7.2 USB Transceiver Electrical Characteristics

VSS = 0V, TA = 25 °C, VDD = 5.0V and execute NOP for each machine cycle, unless otherwise specified

Symbol	Parameter	Test Condition	Limits			Unit
			min	typ	max	
Transmitter						
V _{OH}	Output High Voltage		2.8			V
V _{OL}	Output Low Voltage				0.8	V
I _{OL}	DP/DM output Low Current	V _{PIN} = 0.4V		30		mA
V _{CRS}	Output Cross Over point		1.3		2.0	V
Z _{DRVH}	Output Impedance on Driving High		28		44	Ω
Z _{DRVL}	Output Impedance on Driving Low		28		44	Ω
T _R	Output Rise Time		75		300	ns
T _F	Output Fall Time		75		300	ns
Receiver						
V _{DI}	Differential Input Sensitivity	DP – DM	0.2			V
V _{CM}	Differential Input Common Mode Range		0.8		2.5	V
I _L	Input Leakage current	Pull-up Disabled		<1.0		uA

8 Revision History

Revision	Descriptions	Date
V1.01	Initial Version	2014/03/27