

**AlGaAs Flip-Chip PIN Diode**  
**100MHz to 50GHz**

**MA4AGFCP910**  
 Rev 2.0

**Features**

- Lower Series Resistance, 5.2Ω
- Ultra Low Capacitance, 18 f F
- High Switching Cutoff Frequency, 50 GHz
- 3 Nanosecond Switching Speed
- Driven by Standard TTL
- Silicon Nitride Passivation
- Polyimide Scratch Protection

**Description**

M/A-COM's MA4AGFCP910 is an Aluminum Gallium Arsenide Flip-Chip PIN diode. These devices are fabricated on OMCVD epitaxial wafers using a process designed for high device uniformity and extremely low parasitics. The diodes exhibit an extremely low RC Product, ( 0.1 ps) and 3nS switching characteristics.

They are fully passivated with silicon nitride and have an additional layer of a polymer for scratch protection. The protective coatings prevent damage to the junction and the anode airbridge during handling.

**Top View Shown Is With Diode Junction Up**

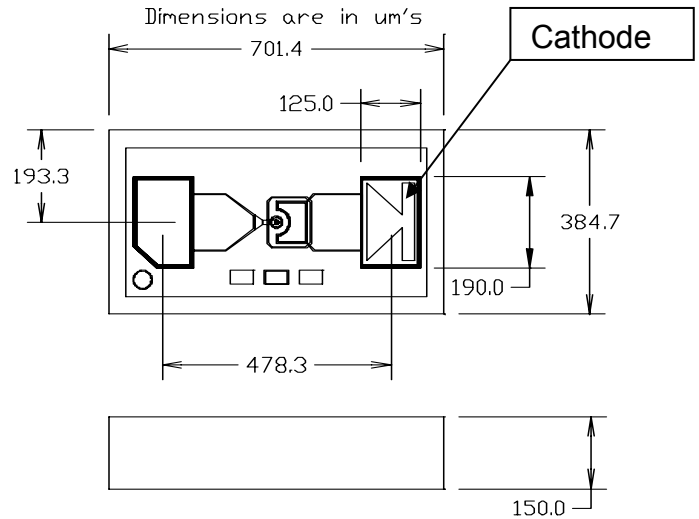

**Package Outline**

**Electrical Specifications at  $T_A = 25^\circ\text{C}$**

Parameters and Test Conditions	Symbol	Units	1 MHz & DC Specifications			10 GHz Reference Data <sup>1,2</sup>		
			Min	Typ.	Max	Min	Typ.	Max.
Total Capacitance at -5 V	Ct	pF		0.018	0.021		0.018	.021
RF Resistance at +10 mA	Rs	$\Omega$					5.2	6.0
Forward Voltage at +10 mA	Vf	Volts		1.33	1.4			
Reverse Breakdown Voltage at 10 $\mu\text{A}$ <sup>3</sup>	Vb	Volts	50	75				
Minority Carrier Lifetime	$\tau_L$	nS		4.0				

**Notes:**

1. Capacitance is determined by measuring Single Series Diode Isolation in a 50 ohm line at 10 GHz.
2. Forward Series Resistance is determined by measuring Single Series Diode Insertion Loss in a 50 ohm line at 10 GHz.
3. Reverse current will not exceed 10 microamperes at the Maximum Voltage Rating.

Typical RF Performance

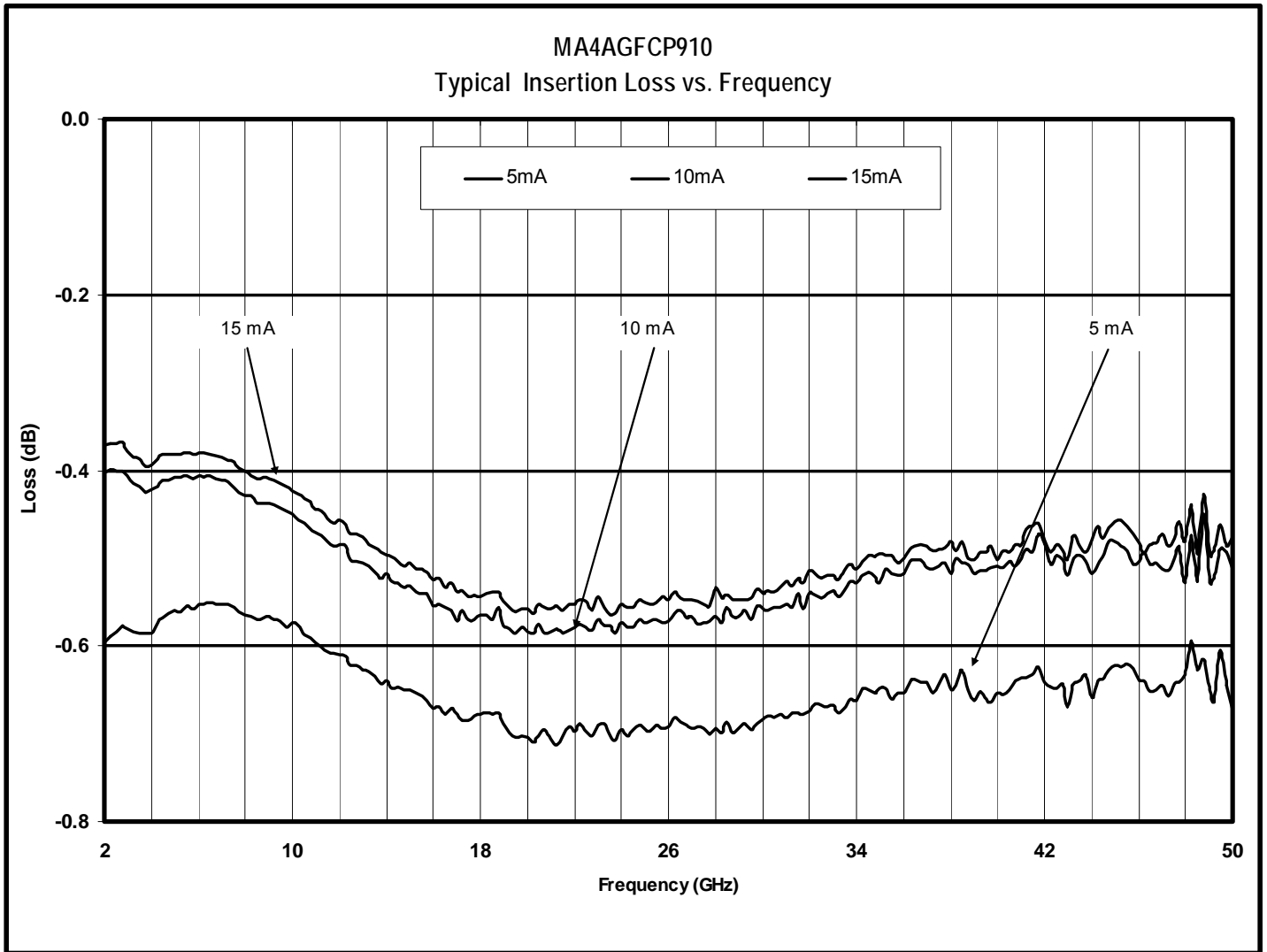

Typical RF Performance

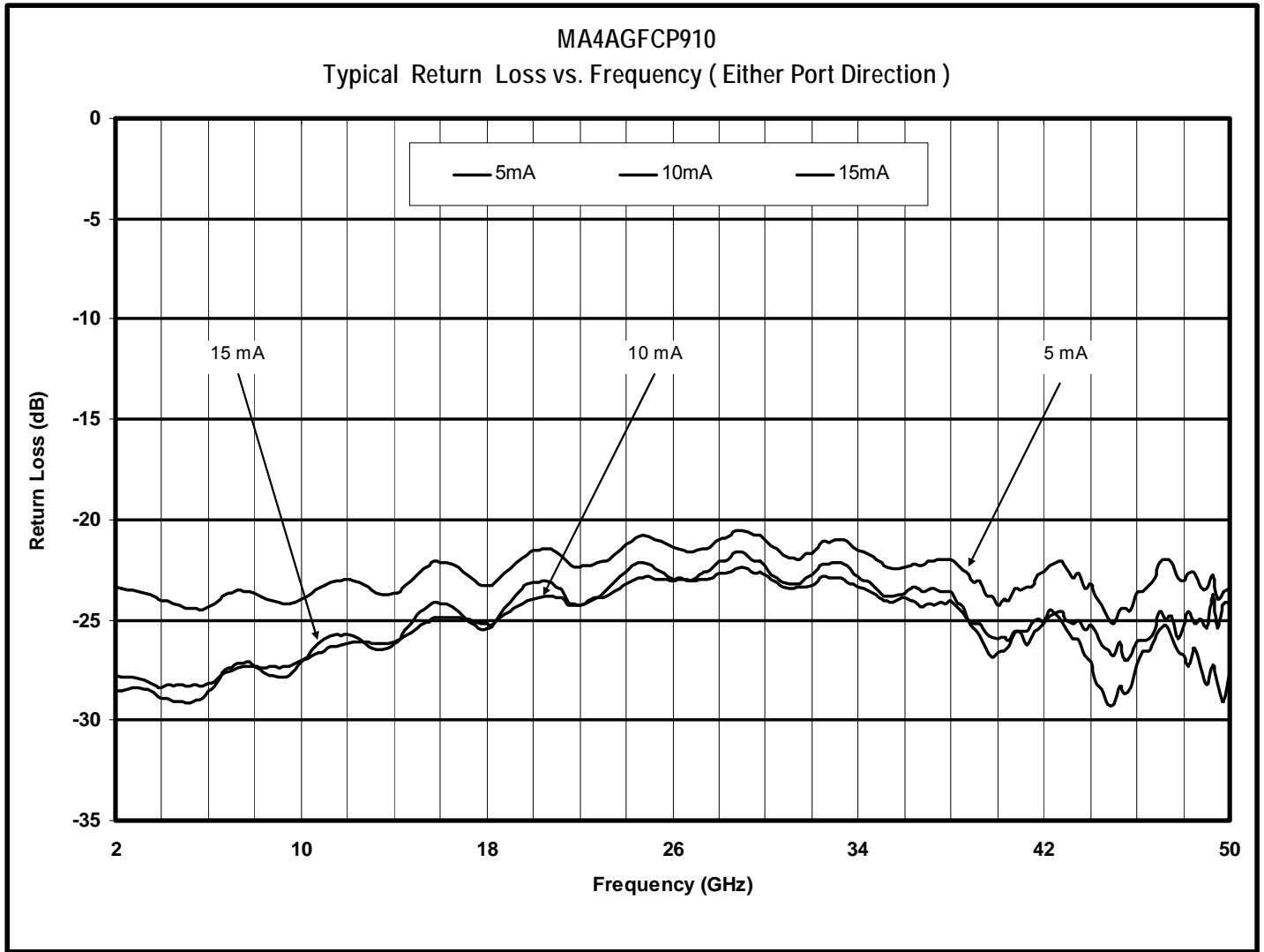

Typical RF Performance

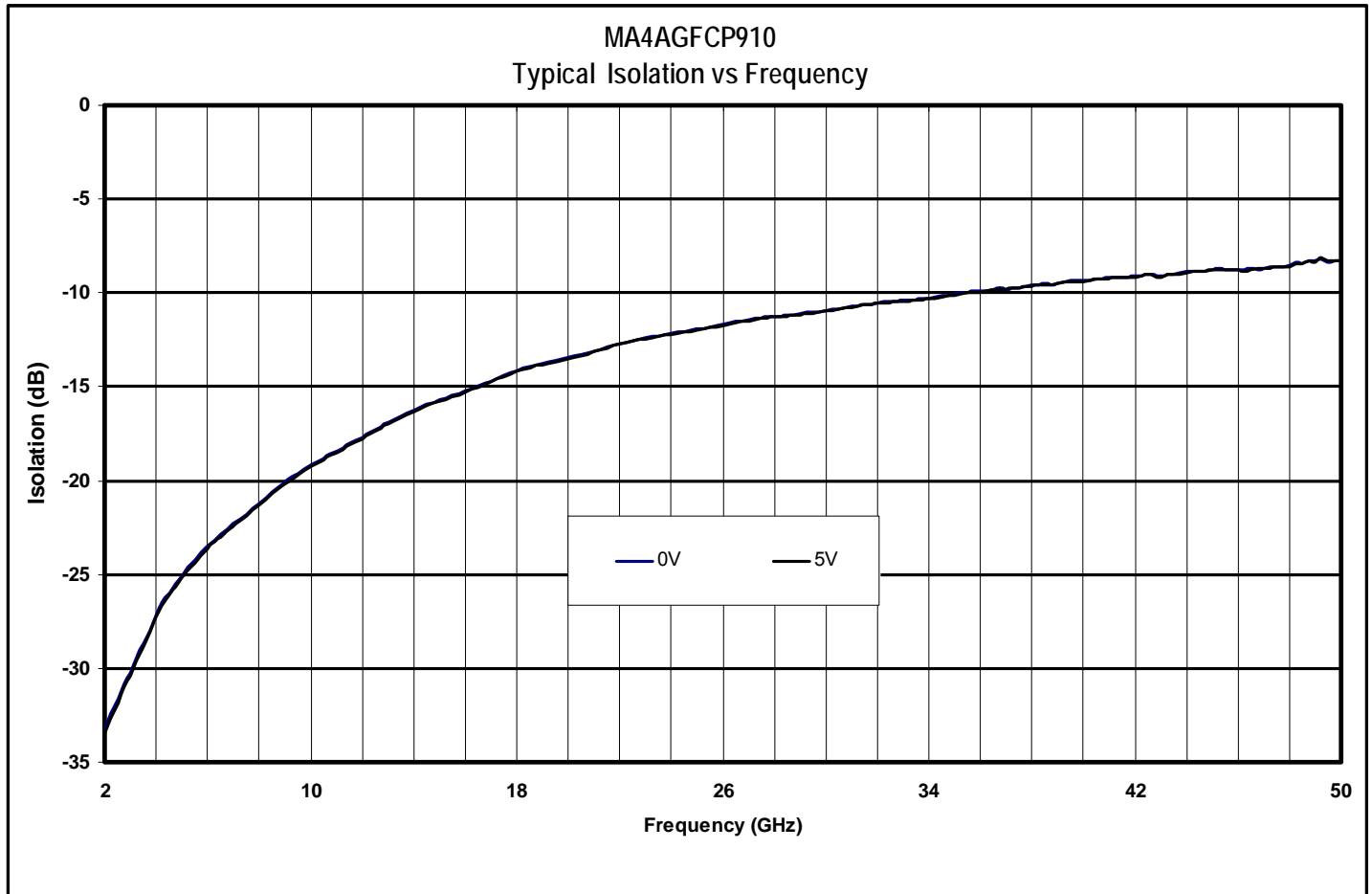

## Applications

The 20 fF capacitance of the MA4AGFCP910 allows use through mmwave switch and switched phase shifter applications. This diode is designed for use in pulsed or CW applications, where single digit nS switching speed is required. For surface mount assembly, the low capacitance of the MA4AGFCP910 makes it ideal for use in microwave multithrow switch assemblies, where the series capacitance of each “off” port adversely loads the input port and affects VSWR.

### Absolute Maximum Ratings @ 25 °C

Parameter	Maximum Ratings
Operating Temperature	-65 °C to +125 °C
Storage Temperature	-65 °C to +150 °C
Junction Temperature	+175 °C
Dissipated RF & DC Power	50 mW
RF C.W. Incident Power	+23 dBm C.W.
Mounting Temperature	+300 °C for 10 seconds

**Note:** Exceeding these limits may cause permanent damage.

## Device Installation Procedures

The following guidelines should be observed to avoid damaging GaAs Flip-Chips.

### Cleanliness

These devices should be handled in a clean environment.

Do Not attempt to Clean Die After installation.

### Static Sensitivity

Gallium arsenide PIN diodes are ESD sensitive and can be damaged by static electricity. Proper ESD techniques should be used when handling these devices. These devices are rated Class 0, ( 0-199V ) per HBM MIL-STD-883, method 3015.7

[C = 100pF ±10%, R = 1.5kW ±1%]. Even though tested die pass 50V ESD, they must be handled in a static-free environment.

## General Handling

These devices have a polymer layer which provides scratch protection for the junction area and the anode air bridge. Die can be handled with plastic tweezers or picked and placed with a #27 tip vacuum pencil.

## Assembly Requirements using Electrically Conductive Ag Epoxy and Solder

These chips are designed to be inserted onto hard or soft substrates with the junction side down. They should be mounted onto silk-screened circuits using Electrically Conductive Ag Epoxy, approximately 1-2 mils in thickness and cured at approximately 90°C to 150 °C per manufacturer’s schedule. For extended cure times > 30 minutes, temperatures must be below 200 °C.

Sn Rich Solders are not recommended due to the Tungsten Metallization scheme beneath the gold contacts. Indalloy or 80 Au/20 Sn Solders are acceptable. Maximum soldering temperature must be < 300 °C for < 10 sec.

## Ordering Information

Part Number	Packaging
MA4AGCP910	Die in Carrier
MADP-000910-13050T	Tape/Reel

## Circuit Mounting Dimensions ( Inches )

